

Problem 1.1

If 60 C of charge pass through an electric conductor in 30 seconds, determine the current in the conductor.

Suggested Solution

$$i = \frac{\Delta Q}{\Delta t} = \frac{60}{30} = 2 \text{ A}$$

$$i = 2 \text{ A}$$

Problem 1.2

If the current in an electric conductor is 2.4 A, how many coulombs of charge pass any point in a 30 second interval?

Suggested Solution

$$\Delta Q = i \times \Delta t = 2.4 \times 30 = 72 C$$

$$\Delta Q = 72 C$$

Problem 1.3

Determine the time interval required for a 12-A battery charger to deliver 4800 C.

Suggested Solution

$$\Delta t = \frac{\Delta Q}{i} = \frac{4800}{12} = 400 \text{ s}$$

$$\Delta t = 400 \text{ s}$$

Problem 1.4

A lightning bolt carrying 30,000 A lasts for 50 microseconds. If the lightning strikes an airplane flying at 20,000 feet, what is the charge deposited on the plane?

Suggested Solution

$$\Delta Q = i \times \Delta t = 30,000(50 \times 10^{-6}) = 1.5 C$$

$$\Delta Q = 1.5 C$$

Problem 1.5

Determine the energy required to move 240 C through 6 V.

Suggested Solution

$$\Delta w = V \times \Delta Q = 6 \times 240 = 1440 J$$

$$\Delta w = 1440 J$$

Problem 1.6

Determine the amount of power absorbed or supplied by the element shown if

(a) $V_1 = 4V, I = 2A$

(b) $V_1 = -4V, I = -2A$

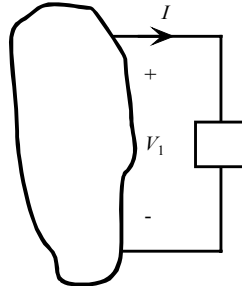

Suggested Solution

(a) $P = 4 \times 2 = 8W$

8W absorbed

(b) $P = (-4)(-2) = 8W$

8W absorbed

Problem 1.7

Determine the amount of power absorbed or supplied by the element shown if

(a) $V_1 = -6V, I = 3A$

(b) $V_1 = 6V, I = -3A$

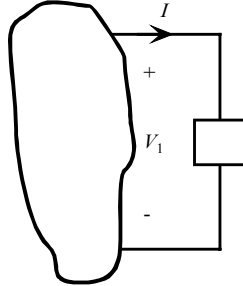

Suggested Solution

(a) $P = (-6) \times 3 = -18W$

18W supplied

(b) $P = 6 \times (-3) = -18W$

18W supplied

Problem 1.8

Determine the missing quantity in the circuits shown.

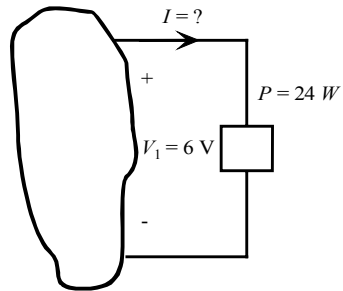

(a)

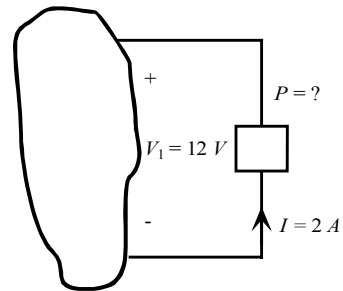

(b)

Suggested Solution

(a) $P = 6 \times I = 24 \Rightarrow I = 4\text{ A}$

$I = 4\text{ A}$

(b) $P = 12 \times (-2) = -24\text{ W}$

$P = 24\text{ W}$ supplied

Problem 1.9

Determine the missing quantity in the circuits shown.

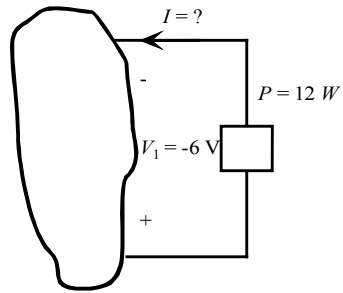

(a)

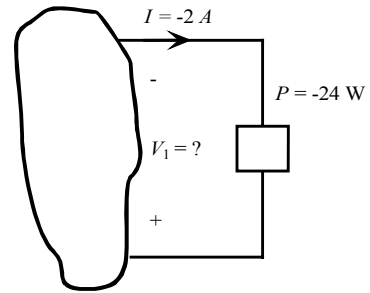

(b)

Suggested Solution

$$(a) P = (-6) \times I = 12 \Rightarrow I = -2\text{ A}$$

$$I = -2\text{ A}$$

$$(b) P = V_1 \times [-(-2)] = -24 \Rightarrow V_1 = -12\text{ V}$$

$$V_1 = -12\text{ V}$$

Problem 1.10

Determine the missing quantity in the circuits shown.

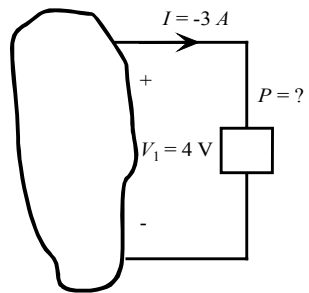

(a)

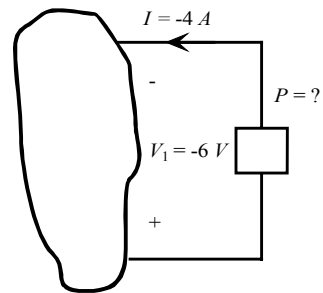

(b)

Suggested Solution

$$(a) P = 4 \times (-3) = -12 W$$

$$P = 12 W \text{ supplied}$$

$$(b) P = (-6) \times (-4) = 24 W$$

$$P = 24 W \text{ absorbed}$$

Problem 1.11

Determine the power supplied to the elements shown.

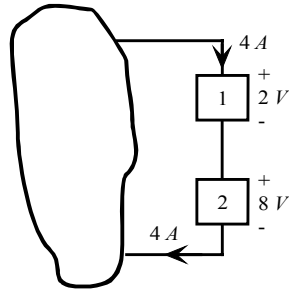

Suggested Solution

$$P_1 = 2 \times 4 = 8\text{ W}$$

$$P_1 = 8\text{ W}$$

$$P_2 = 8 \times 4 = 32\text{ W}$$

$$P_2 = 32\text{ W}$$

Problem 1.12

Determine the power supplied to the elements shown.

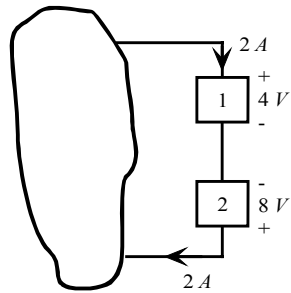

Suggested Solution

$$P_1 = 4 \times 2 = 8\text{ W}$$

$$P_1 = 8\text{ W}$$

$$P_2 = (-8) \times 2 = -16\text{ W}$$

$$P_2 = -16\text{ W}$$

Problem 1.13

Two elements are connected in series, as shown. Element 1 supplies $24W$ of power. Is element 2 absorbing or supplying power, and how much?

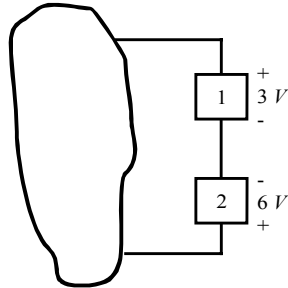

Suggested Solution

If element 1 is supplying power, the direction of the current must be as shown.

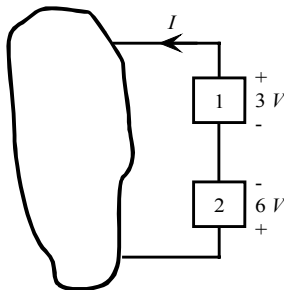

$$P_1 = 3 \times (-I) = -24 \Rightarrow I = 8A$$

$$\text{Then, } P_2 = 6 \times 8 = 48W$$

$$P_2 = 48W \text{ absorbed}$$

Problem 1.14

Two elements are connected in series, as shown. Element 1 absorbs $36W$ of power. Is element 2 absorbing or supplying power, and how much?

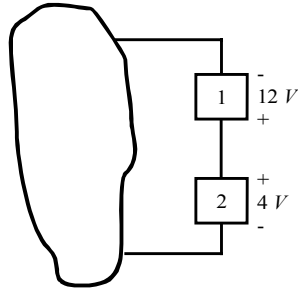

Suggested Solution

If element 1 is absorbing power, the direction of the current must be as shown.

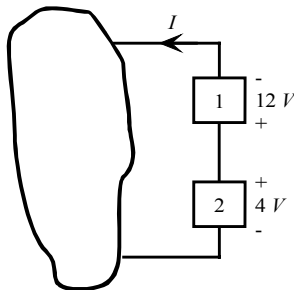

$$P_1 = 12 \times I = 36 \Rightarrow I = 3 A$$

$$\text{Then, } P_2 = 4 \times (-3) = -12 W$$

$$P_2 = 12 W \text{ supplied}$$

Problem 1.15

Determine the power that is absorbed or supplied by the circuit elements shown.

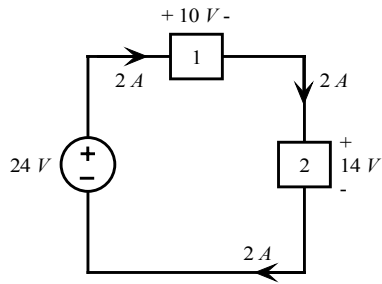

(a)

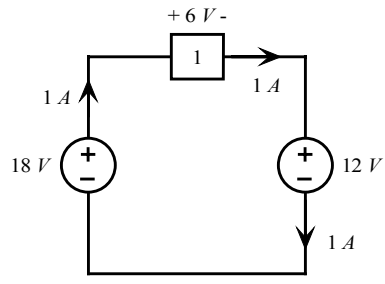

(b)

Suggested Solution

(a) $P_{24V} = 24 \times (-2) = -48W$

$P_{24V} = 48W$ supplied

$P_1 = 10 \times 2 = 20W$

$P_1 = 20W$ absorbed

$P_2 = 14 \times 2 = 28W$

$P_2 = 28W$ absorbed

(b) $P_{18V} = 18 \times (-1) = -18W$

$P_{18V} = 18W$ supplied

$P_1 = 6 \times 1 = 6W$

$P_1 = 6W$ absorbed

$P_2 = 12 \times 1 = 12W$

$P_2 = 12W$ absorbed

Problem 1.16

Find the power that is absorbed or supplied by the circuit elements shown.

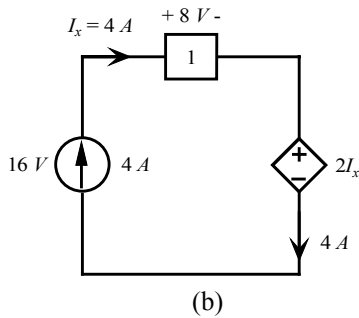
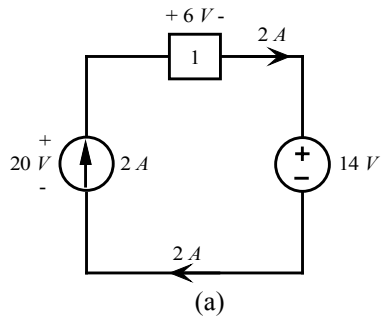

Suggested Solution

(a) $P_{2A} = 20 \times (-2) = -40W$

$P_{2A} = 40W$ supplied

$P_1 = 6 \times 2 = 12W$

$P_1 = 12W$ absorbed

$P_{14V} = 14 \times 2 = 28W$

$P_{14V} = 28W$ absorbed

(b) $P_{4A} = 16 \times (-4) = -64W$

$P_{4A} = 64W$ supplied

$P_1 = 8 \times 4 = 32W$

$P_1 = 32W$ absorbed

$P_{2I_x} = (2I_x) \times 4 = 8 \times 4 = 32W$

$P_{2I_x} = 32W$ absorbed

Problem 1.17

Compute the power that is absorbed or supplied by the elements in the network shown.

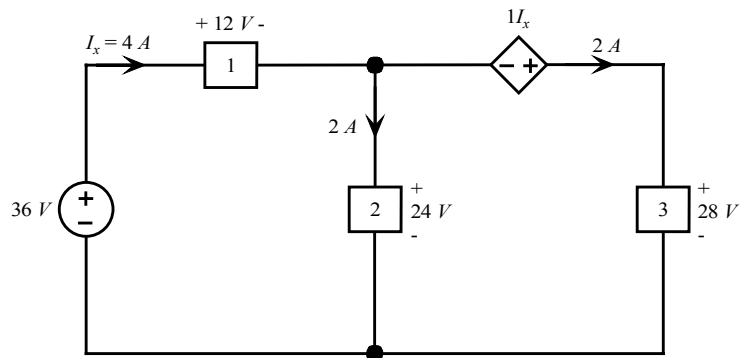

Suggested Solution

$$P_{36V} = 36 \times (-4) = -144W$$

$$P_{36V} = 144W \text{ supplied}$$

$$P_1 = 12 \times 4 = 48W$$

$$P_1 = 48W \text{ absorbed}$$

$$P_2 = 24 \times 2 = 48W$$

$$P_2 = 48W \text{ absorbed}$$

$$P_{1I_x} = (1I_x) \times (-2) = 4 \times (-2) = -8W$$

$$P_{1I_x} = 8W \text{ supplied}$$

$$P_3 = 28 \times 2 = 56W$$

$$P_3 = 56W \text{ absorbed}$$

Problem 1.18

Find I_x in the network shown.

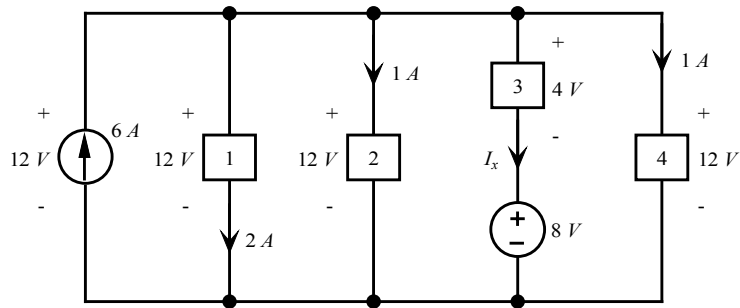

Suggested Solution

$$P_{6A} = 12 \times (-6) = -72W \text{ or } 72W \text{ supplied}$$

$$P_1 = 12 \times 2 = 24W \text{ absorbed}$$

$$P_2 = 12 \times 1 = 12W \text{ absorbed}$$

$$P_3 = 4 \times I_x = 4I_x W \text{ absorbed}$$

$$P_{8V} = 8 \times I_x = 8I_x W \text{ absorbed}$$

$$P_4 = 12 \times 1 = 12W \text{ absorbed}$$

Since *Power Supplied* = *Power Absorbed*, then

$$72 = 24 + 12 + 4I_x + 8I_x + 12$$

$$\text{or } 12I_x = 24.$$

Therefore, $I_x = 2A$.

$$I_x = 2A$$

Problem 1.19

Is the source V_s in the network shown absorbing or supplying power, and how much?

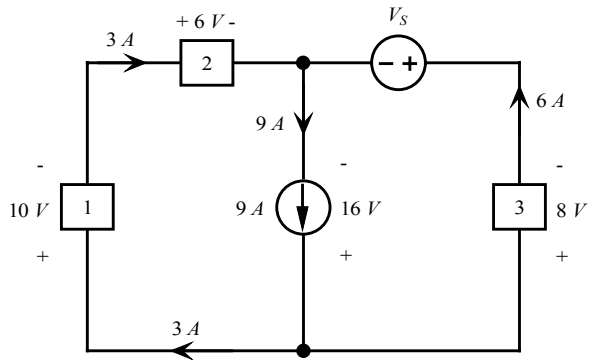

Suggested Solution

$$P_1 = 10 \times 3 = 30W \text{ absorbed}$$

$$P_2 = 6 \times 3 = 18W \text{ absorbed}$$

$$P_{9A} = 16 \times (-9) = -144W \text{ or } 144W \text{ supplied}$$

$$P_3 = 8 \times 6 = 48W \text{ absorbed}$$

In order to satisfy *Conservation of Power*,

$$P_1 + P_2 + P_{9A} + P_{V_s} + P_3 = 0$$

$$\text{or } 30 + 18 - 144 + P_{V_s} + 48 = 0$$

Therefore, $P_{V_s} = 48W$.

$P_{V_s} = 48W \text{ absorbed}$

Problem 1.20

Find V_S in the network shown.

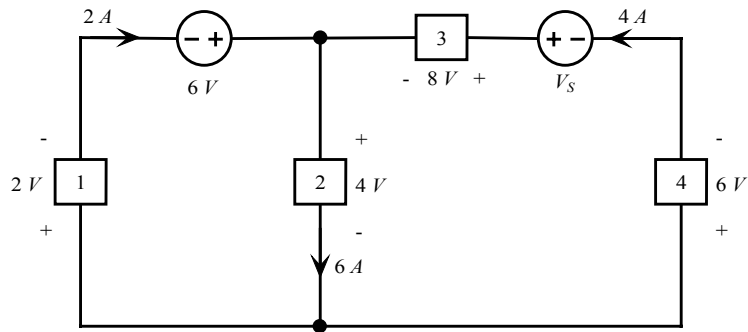

Suggested Solution

$$P_1 = 2 \times 2 = 4W \text{ absorbed}$$

$$P_{6V} = 6 \times (-2) = -12W \text{ or } 12W \text{ supplied}$$

$$P_2 = 4 \times 6 = 24W \text{ absorbed}$$

$$P_3 = 8 \times 4 = 32W \text{ absorbed}$$

$$P_{V_S} = V_S \times (-4) = -4V_S W \text{ or } 4V_S W \text{ supplied}$$

$$P_4 = 6 \times 4 = 24W \text{ absorbed}$$

In order to satisfy *Conservation of Power*,

$$P_1 + P_{6V} + P_2 + P_3 + P_{V_S} + P_4 = 0$$

$$\text{or } 4 - 12 + 24 + 32 - 4V_S + 24 = 0$$

Therefore, $4V_S = 72$ or $V_S = 18V$.

$$V_S = 18V$$

Problem 1.21

Find I_o in the network shown.

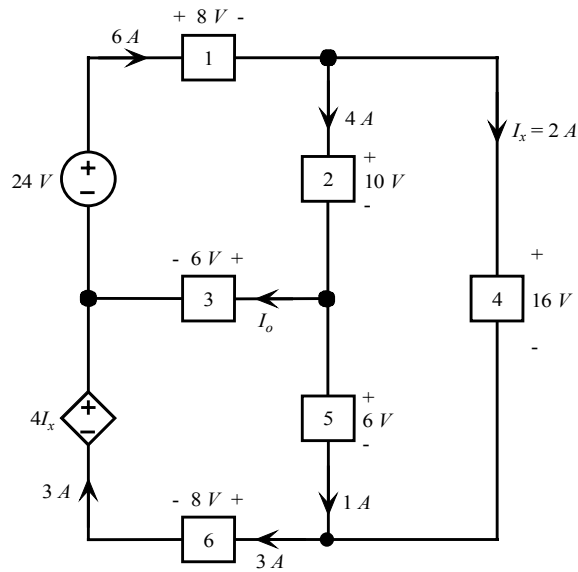

Suggested Solution

$$P_{24V} = 24 \times (-6) = -144W \text{ or } 144W \text{ supplied}$$

$$P_{4I_x} = (4I_x) \times (-3) = 8 \times (-3) = -24W \text{ or } 24W \text{ supplied}$$

$$P_1 = 8 \times 6 = 48W \text{ absorbed}$$

$$P_3 = 6 \times I_o = 6I_o W \text{ absorbed}$$

$$P_6 = 8 \times 3 = 24W \text{ absorbed}$$

$$P_2 = 10 \times 4 = 40W \text{ absorbed}$$

$$P_5 = 6 \times 1 = 6W \text{ absorbed}$$

$$P_4 = 16 \times 2 = 32W \text{ absorbed}$$

In order to satisfy *Conservation of Power*,

$$P_{24V} + P_{4I_x} + P_1 + P_3 + P_6 + P_2 + P_5 + P_4 = 0$$

$$\text{or } -144 - 24 + 48 + 6I_o + 24 + 40 + 6 + 32 = 0$$

Therefore, $6I_o = 18$ or $I_o = 3A$.

$$I_o = 3A$$

Problem 2.1

Find the current I and the power supplied by the source in the network shown.

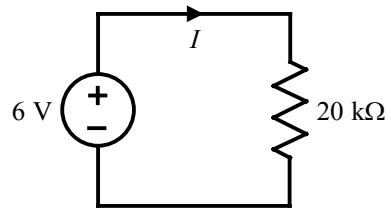

Suggested Solution

$$I = \frac{6}{20 \times 10^3} = 0.3 \text{ mA}$$

$$P = VI = (6)(0.3 \times 10^{-3}) = 1.8 \text{ mW}$$

Problem 2.2

In the circuit shown, find the voltage across the current source and the power absorbed by the resistor.

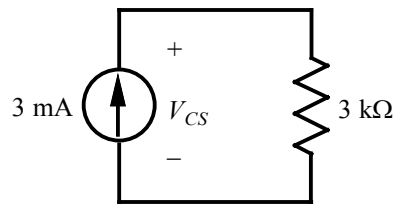

Suggested Solution

$$V_{CS} = (3 \times 10^{-3})(3 \times 10^3) = 9 \text{ V}$$

$$P = VI = (3 \times 10^{-3})(9) = 27 \text{ mW}$$

Problem 2.3

If the 10-k Ω resistor in the network shown absorbs 2.5 mW, find V_s .

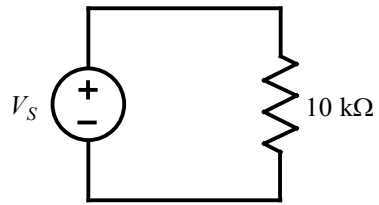

Suggested Solution

$$P = \frac{V_s^2}{10 \text{ k}\Omega}$$

$$\text{or } V_s = \sqrt{P \times R} = \sqrt{(2.5 \times 10^{-3})(10 \times 10^3)} = 5 \text{ V}$$

Problem 2.4

In the network shown, the power absorbed by R_x is 5 mW. Find R_x .

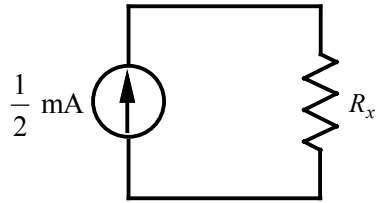

Suggested Solution

$$R_x = \frac{P}{I^2} = \frac{5 \times 10^{-3}}{(0.5 \times 10^{-3})^2} = 20 \text{ k}\Omega$$

Problem 2.5

In the network shown, the power absorbed by R_x is 20 mW. Find R_x .

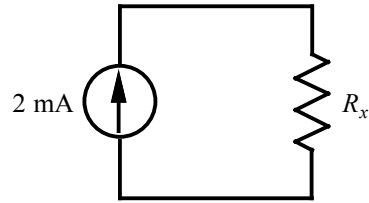

Suggested Solution

$$R = \frac{P}{I^2} = \frac{20 \times 10^{-3}}{(2 \times 10^{-3})^2} = 5 \text{ k}\Omega$$

Problem 2.6

A model for a standard two D-cell flashlight is shown. Find the power dissipated in the lamp.

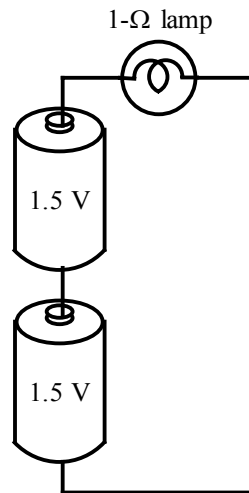

Suggested Solution

$$V_{lamp} = 1.5 + 1.5 = 3 \text{ V}$$

$$P_{lamp} = \frac{V_{lamp}^2}{R_{lamp}} = \frac{(3)^2}{1} = 9 \text{ W}$$

Problem 2.7

An automobile uses two halogen headlights connected as shown. Determine the power supplied by the battery if each headlight draws 3 A of current.

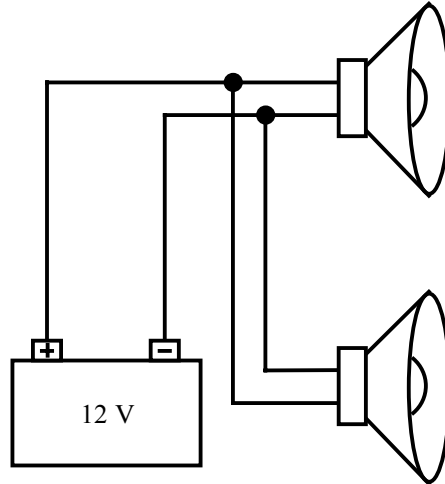

Suggested Solution

$$P_s = VI = (12)(3+3) = 72 \text{ W}$$

Problem 2.8

Many years ago a string of Christmas tree lights was manufactured in the form shown in (a). Today the lights are manufactured as shown in (b). Is there a good reason for this change?

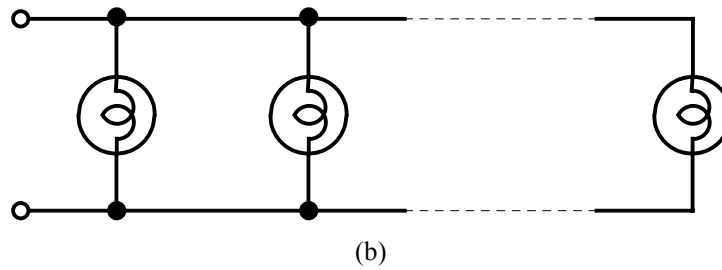
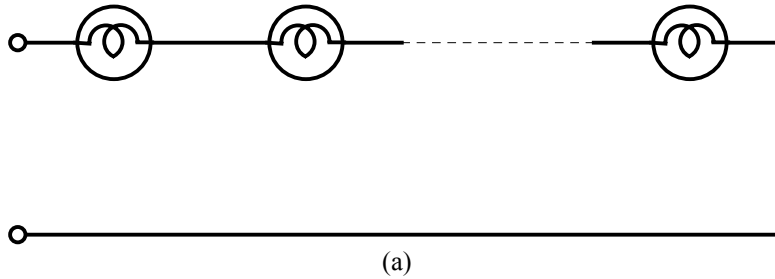

Suggested Solution

First of all, one must recognize the fact that a failed lamp becomes an open circuit. Then:

In (a), one faulty lamp would take out the whole string. There would be no way to identify the faulty lamp.

In (b), if one lamp fails, the others stay lit. It is easy to identify the faulty lamp.

Problem 2.9

Find I_1 in the network shown.

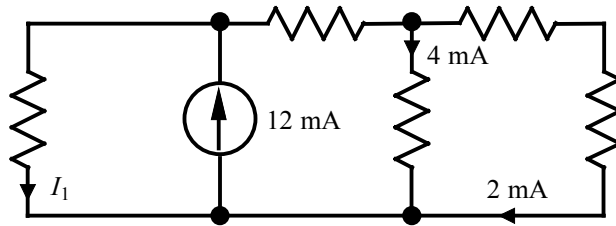

Suggested Solution

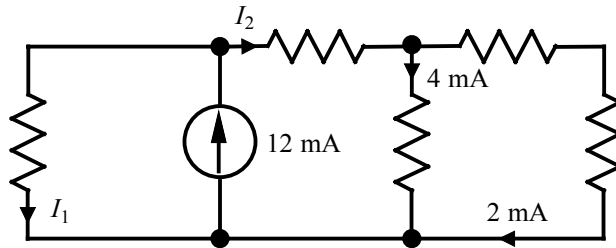

$$I_2 = 0.004 + 0.002 = 0.006 \text{ A}$$

$$0.012 = I_1 + I_2$$

$$\Rightarrow I_1 = 6 \text{ mA}$$

Problem 2.10

Find I_1 and I_2 in the circuit shown.

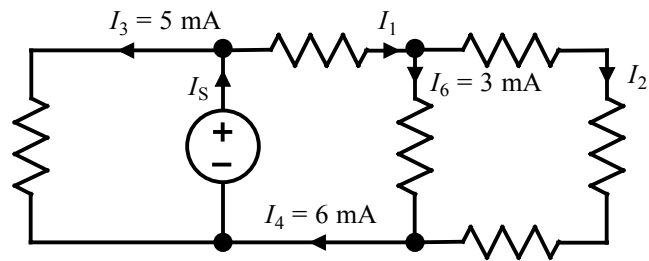

Suggested Solution

By KCL, $I_1 = I_4 = 6 \text{ mA}$

Also, $I_6 + I_2 = I_4$

or $0.003 + I_2 = 0.006$

$\Rightarrow I_2 = 3 \text{ mA}$

Problem 2.11

Find I_x and I_y in the network shown.

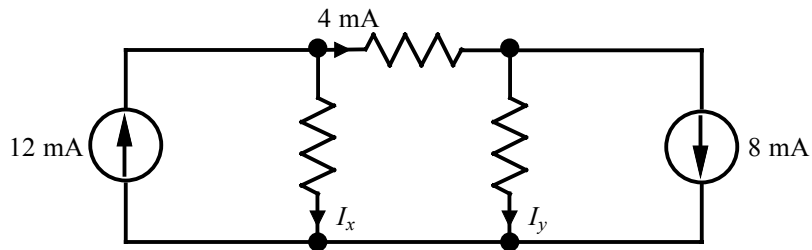

Suggested Solution

$$0.012 = 0.004 + I_x$$

$$\Rightarrow I_x = 8 \text{ mA}$$

$$0.004 = I_y + 0.008$$

$$\Rightarrow I_y = -4 \text{ mA}$$

Problem 2.12

Find I_x , I_y and I_z in the circuit shown.

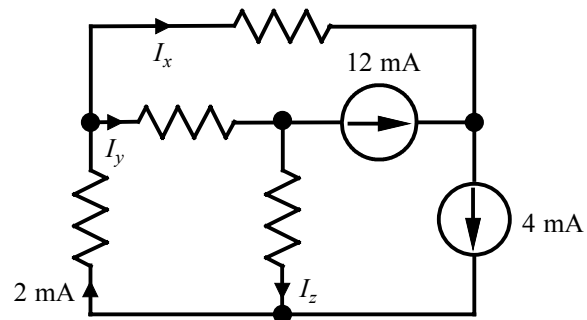

Suggested Solution

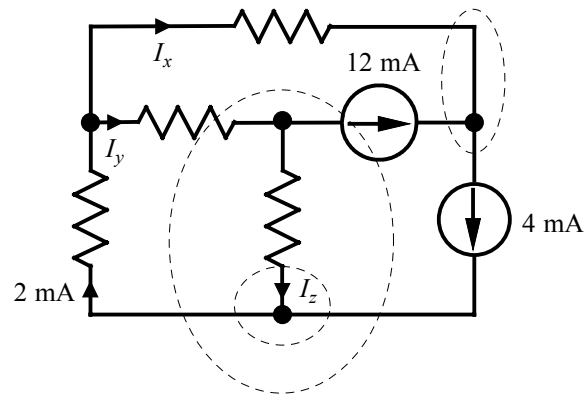

$$I_x + 0.012 = 0.004$$

$$\Rightarrow I_x = -8 \text{ mA}$$

$$I_y + 0.004 = 0.002 + 0.012$$

$$\Rightarrow I_y = 10 \text{ mA}$$

$$I_z + 0.004 = 0.002$$

$$\Rightarrow I_z = -2 \text{ mA}$$

Problem 2.13

Find I_x in the circuit shown.

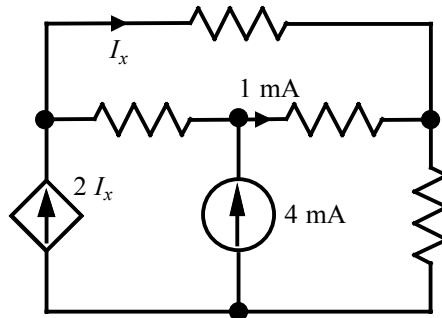

Suggested Solution

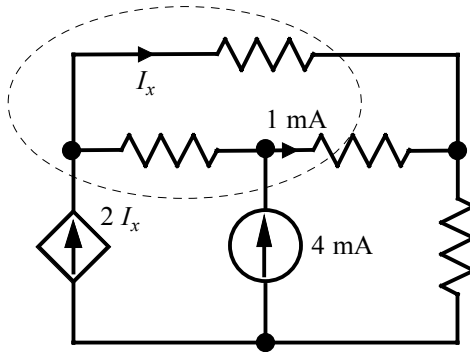

$$I_x + 0.001 = 0.004 + 2I_x$$

$$\Rightarrow I_x = -3 \text{ mA}$$

Problem 2.14

Find I_x , I_y and I_z in the network shown.

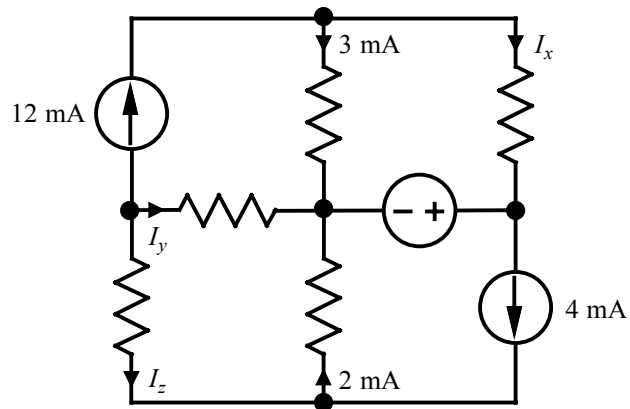

Suggested Solution

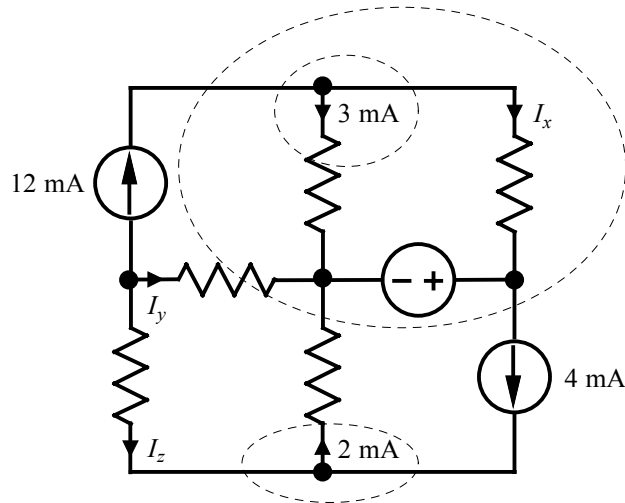

$$I_x + 0.003 = 0.012$$

$$\Rightarrow I_x = 9 \text{ mA}$$

$$I_y + 0.012 + 0.002 = 0.004$$

$$\Rightarrow I_y = -10 \text{ mA}$$

$$I_z + 0.004 = 0.002$$

$$\Rightarrow I_z = -2 \text{ mA}$$

Problem 2.15

Find I_x in the circuit shown.

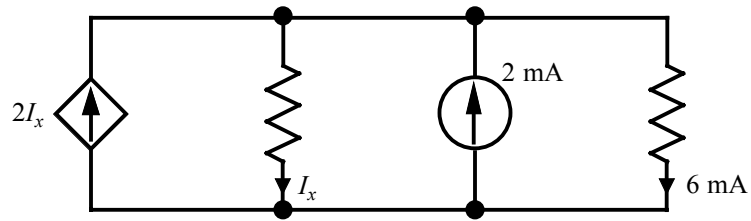

Suggested Solution

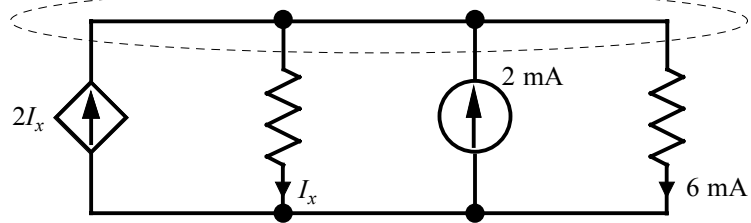

$$2I_x + 0.002 = I_x + 0.006$$

$$\Rightarrow I_x = 4 \text{ mA}$$

Problem 2.16

Find I_x in the network shown.

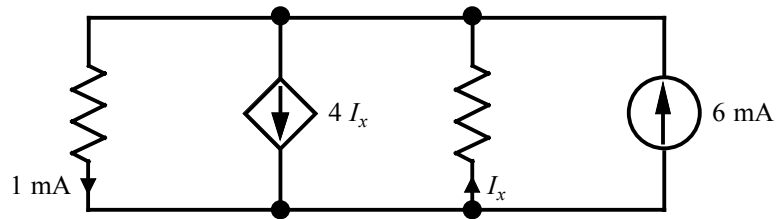

Suggested Solution

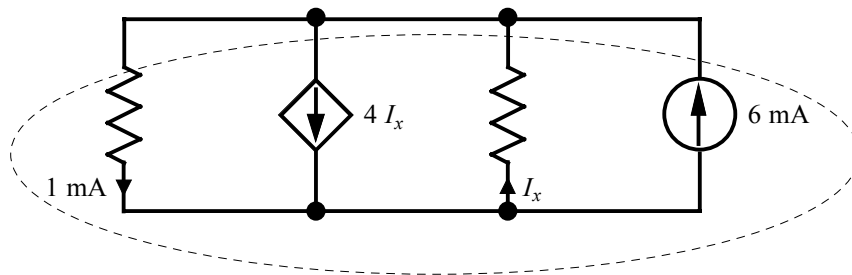

$$4I_x + 0.001 = I_x + 0.006$$

$$\Rightarrow I_x = \frac{5}{3} \text{ mA}$$

Problem 2.17

Find V_x in the circuit shown.

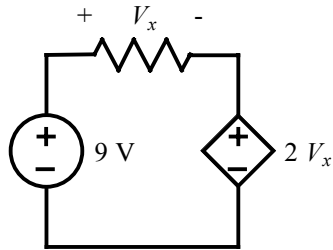

Suggested Solution

$$\text{KVL: } -9 + V_x + 2V_x = 0$$

$$\Rightarrow V_x = 3 \text{ V}$$

Problem 2.18

Find V_{bd} in the circuit shown.

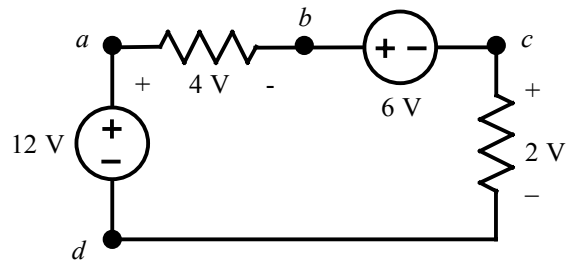

Suggested Solution

$$\text{KVL: } -12 + 4 + V_{bd} = 0$$

$$\Rightarrow V_{bd} = 8 \text{ V}$$

Problem 2.19

Find V_{ad} in the network shown.

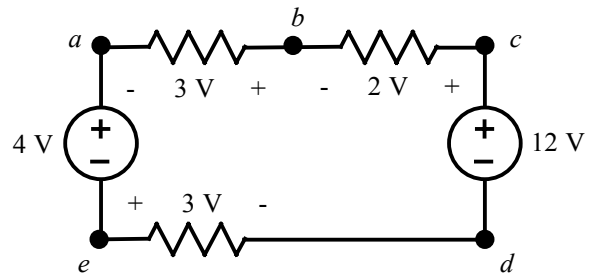

Suggested Solution

$$\text{KVL: } -4 + V_{ad} - 3 = 0$$

$$\Rightarrow V_{ad} = 7 \text{ V}$$

Problem 2.20

Find V_{af} and V_{ec} in the circuit shown.

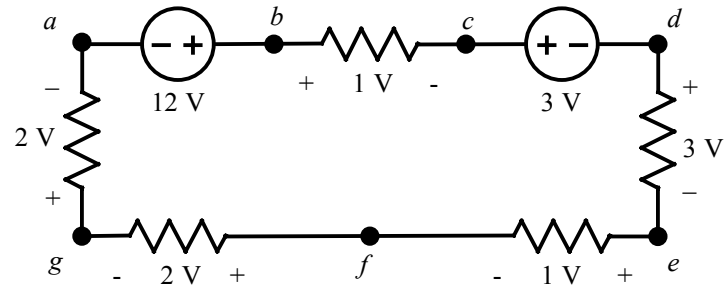

Suggested Solution

$$\text{KVL: } 2 + V_{af} + 2 = 0$$

$$\Rightarrow V_{af} = -4 \text{ V}$$

$$\text{KVL: } V_{ec} + 3 + 3 = 0$$

$$\Rightarrow V_{ec} = -6 \text{ V}$$

Problem 2.21

Find V_{ac} in the circuit shown.

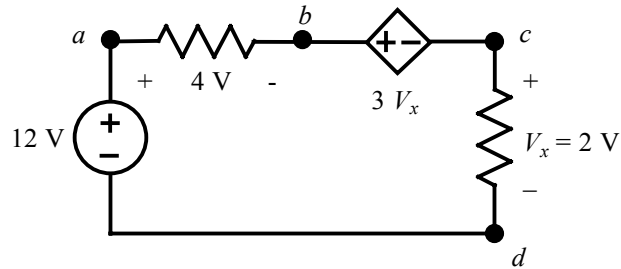

Suggested Solution

$$\text{KVL: } V_{ac} + 2 - 12 = 0$$

$$\Rightarrow V_{ac} = 10\text{ V}$$

Problem 2.22

Find V_{ad} and V_{ce} in the circuit shown.

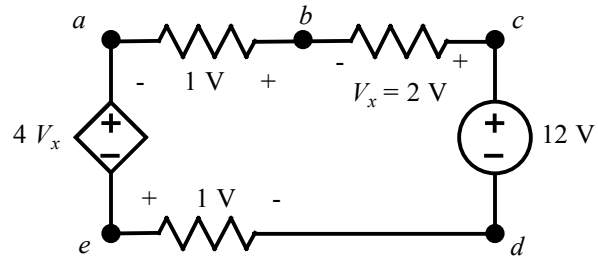

Suggested Solution

$$\text{KVL: } V_{ad} - 12 + 2 + 1 = 0$$

$$\Rightarrow V_{ad} = 9 \text{ V}$$

$$\text{KVL: } V_{ce} + 1 - 12 = 0$$

$$\Rightarrow V_{ce} = 11 \text{ V}$$

Problem 2.23

Find V_{ab} in the network shown.

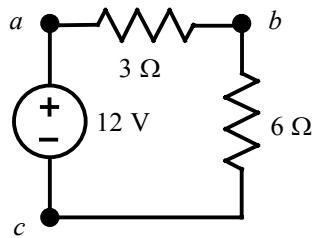

Suggested Solution

Using voltage division,

$$V_{ab} = \left(\frac{3}{3+6} \right) 12 = 4\ \text{V}$$

Problem 2.24

Find V_{bd} in the network shown.

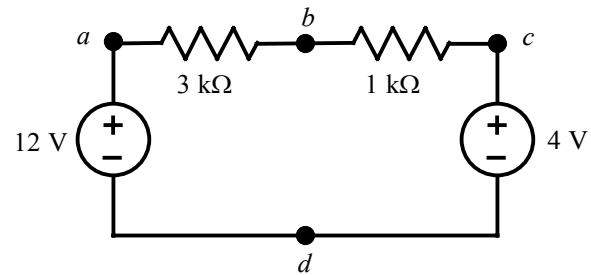

Suggested Solution

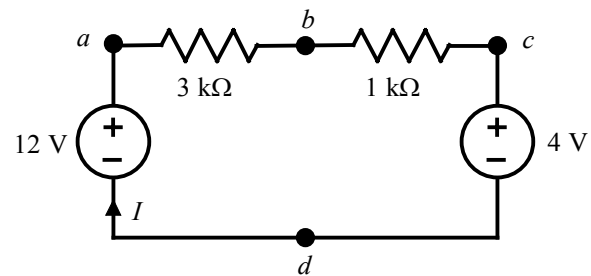

$$I = \frac{12 - 4}{3000 + 1000} = 2 \text{ mA}$$

$$\text{KVL: } V_{bd} - 4 - 1000(0.002) = 0$$

$$\Rightarrow V_{bd} = 6 \text{ V}$$

Problem 2.25

Find V_x in the circuit shown.

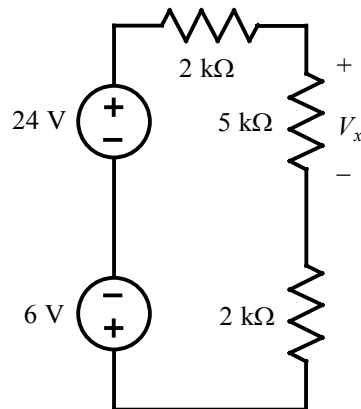

Suggested Solution

Using voltage division,

$$V_x = \left(\frac{5000}{2000 + 5000 + 2000} \right) (24 - 6) = 10 \text{ V}$$

Problem 2.26

Find V_x in the circuit shown.

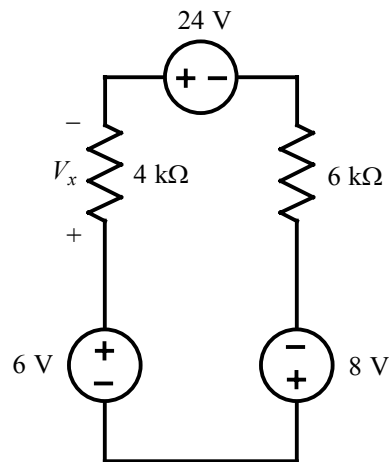

Suggested Solution

Using voltage division,

$$V_x = \left(\frac{4000}{4000 + 6000} \right) (6 + 8 - 24) = -4 \text{ V}$$

Problem 2.27

Find V_x in the network shown.

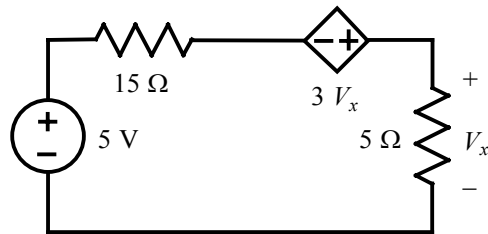

Suggested Solution

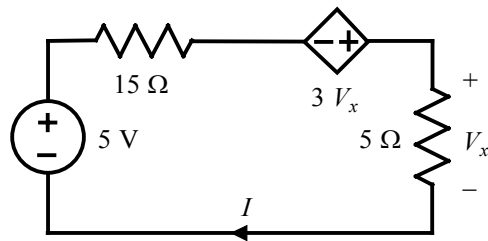

KVL: $-5 + 15I - 3V_x + V_x = 0$, where $V_x = 5I$

Therefore, $-5 + 15I - 3(5I) + 5I = 0$

$$\Rightarrow I = 1 \text{ A}$$

$$\therefore V_x = 5 \text{ V}$$

Problem 2.28

Find V_1 in the network shown.

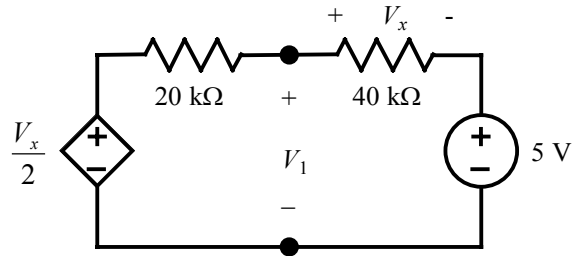

Suggested Solution

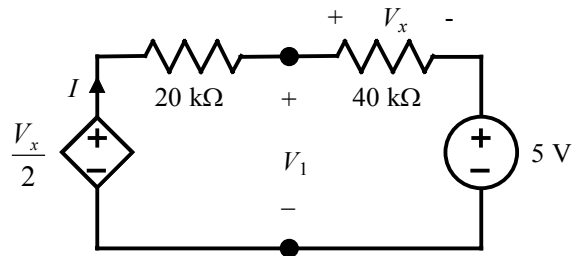

$$\text{KVL: } -\frac{V_x}{2} + 20000I + 40000I + 5 = 0, \text{ where } V_x = 40000I$$

$$\text{Therefore, } -\frac{40000I}{2} + 20000I + 40000I + 5 = 0$$

$$\Rightarrow I = -0.125 \text{ mA}$$

$$V_1 = V_x + 5 = 40000I + 5 = -5 + 5 = 0 \text{ V}$$

Problem 2.29

Find the power absorbed by the 30-k Ω resistor in the circuit shown.

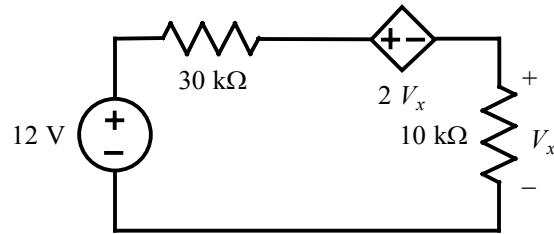

Suggested Solution

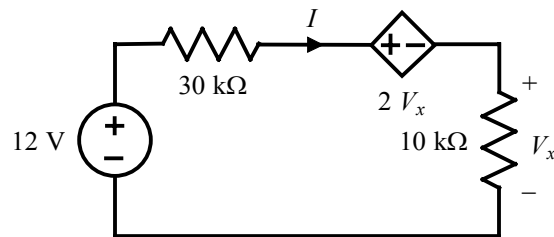

$$\text{KVL: } -12 + 30000I + 2V_x + V_x = 0 \text{ where } V_x = 10000I$$

$$\text{Therefore, } -12 + 30000I + 2(10000I) + 10000I = 0$$

$$\Rightarrow I = 200 \mu\text{A}$$

$$P_{30\text{k}\Omega} = I^2(30000) = (200 \times 10^{-6})^2(30000) = 1.2 \text{ mW}$$

Problem 2.30

Find I_o in the network shown.

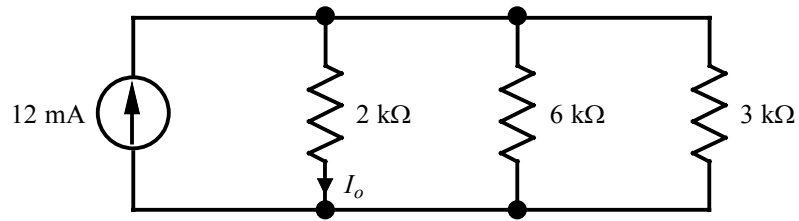

Suggested Solution

$$I_o = \left(\frac{\frac{1}{2000}}{\frac{1}{2000} + \frac{1}{6000} + \frac{1}{3000}} \right) (12 \text{ mA}) = 6 \text{ mA}$$

Problem 2.31

Find I_o in the circuit shown.

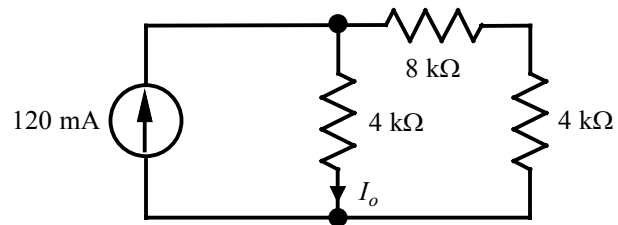

Suggested Solution

Using current division,

$$I_o = \left[\frac{\frac{1}{4000}}{\frac{1}{4000} + \frac{1}{8000 + 4000}} \right] (0.120) = 90 \text{ mA}$$

Problem 2.32

Find I_o in the network shown.

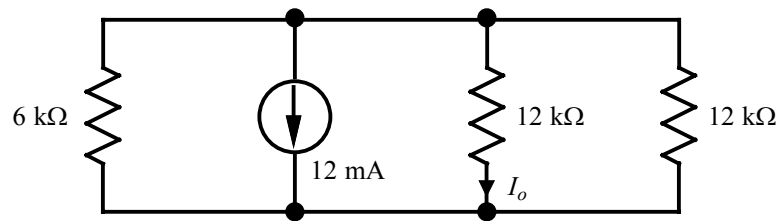

Suggested Solution

Using current division,

$$I_o = - \left(\frac{\frac{1}{12000}}{\frac{1}{6000} + \frac{1}{12000} + \frac{1}{12000}} \right) (0.012) = -3 \text{ mA}$$

Problem 2.33

Find V_o in the circuit shown.

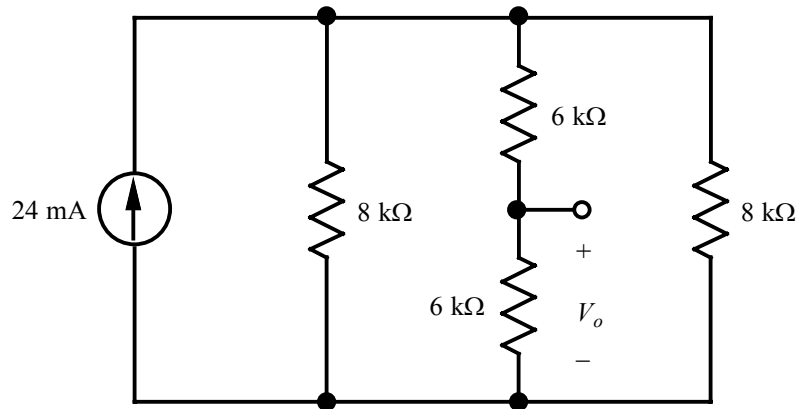

Suggested Solution

Combining the 8-k Ω resistors in parallel yields the following circuit.

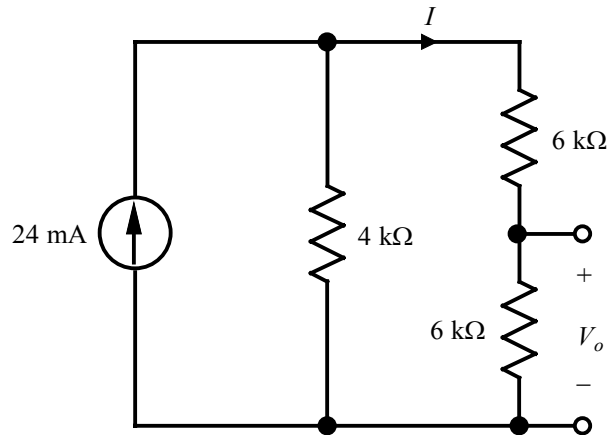

Using current division,

$$I = \left(\frac{\frac{1}{6000 + 6000}}{\frac{1}{4000} + \frac{1}{6000 + 6000}} \right) (0.024) = 6 \text{ mA}$$

Then,

$$V_o = 6000 I = 36 \text{ V}$$

Problem 2.34

Find I_o in the network shown.

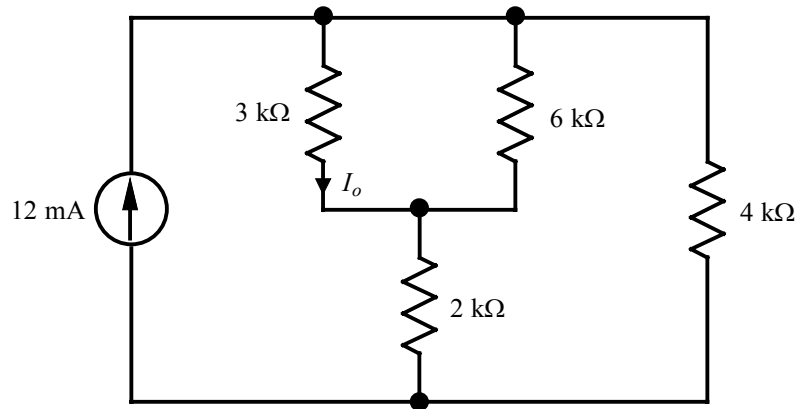

Suggested Solution

Combining the 3-k Ω and 6-k Ω resistors in parallel yields the following equivalent circuit.

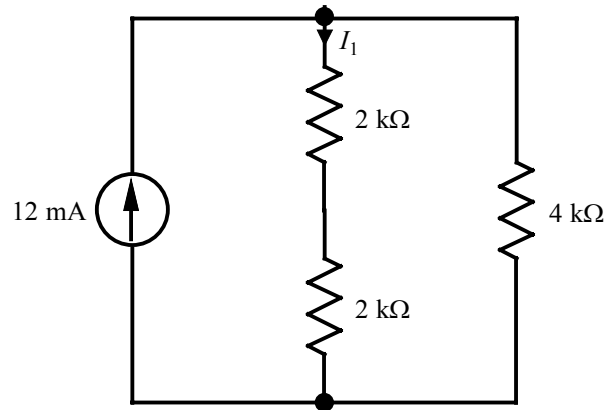

$$I_1 = \left[\frac{4000}{4000 + (2000 + 2000)} \right] (0.012) = 6 \text{ mA}$$

Then,

$$I_o = \left(\frac{6000}{6000 + 3000} \right) I_1 = 4 \text{ mA}$$

Problem 2.35

Determine I_L in the circuit shown.

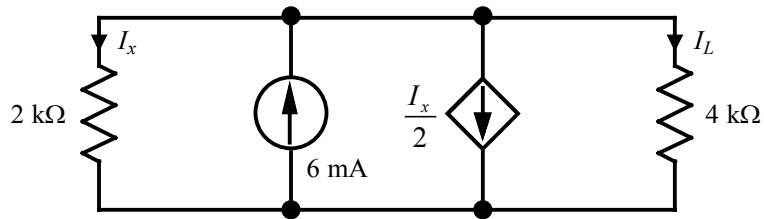

Suggested Solution

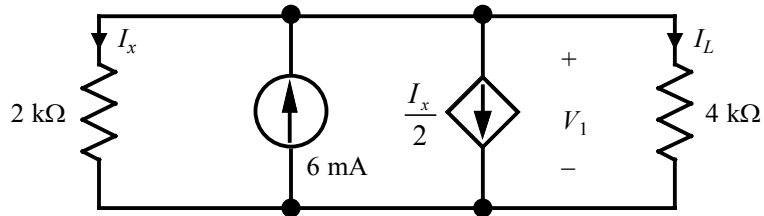

$$\text{KCL: } I_x - 0.006 + \frac{I_x}{2} + I_L = 0, \text{ where } I_x = \frac{V_1}{2000} \text{ and } I_L = \frac{V_1}{4000}$$

Therefore,

$$\frac{V_1}{2000} - 0.006 + \frac{V_1}{4000} + \frac{V_1}{4000} = 0$$

$$\Rightarrow V_1 = 6 \text{ V}$$

Then,

$$I_L = \frac{6}{4000} = 1.5 \text{ mA}$$

Problem 2.36

Determine I_L in the circuit shown.

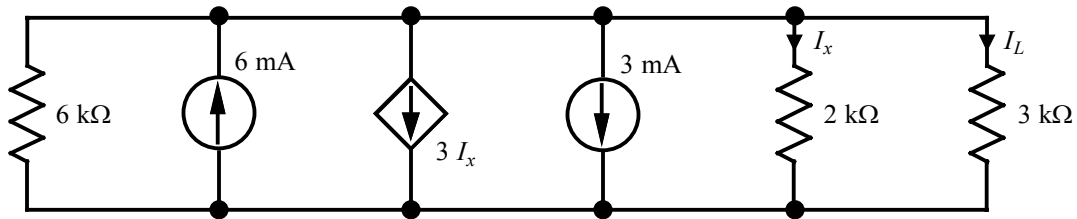

Suggested Solution

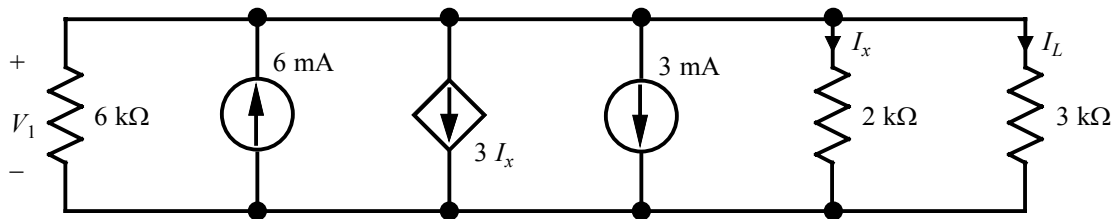

$$\text{KCL: } \frac{V_1}{6000} - 0.006 + 3I_x + 0.003 + I_x + I_L = 0, \text{ where } I_x = \frac{V_1}{2000} \text{ and } I_L = \frac{V_1}{3000}.$$

Therefore,

$$\frac{V_1}{6000} - 0.006 + 3\left(\frac{V_1}{2000}\right) + 0.003 + \frac{V_1}{2000} + \frac{V_1}{3000} = 0$$

$$\Rightarrow V_1 = \frac{6}{5} = 1.2 \text{ V}$$

and

$$I_L = \frac{1.2}{3000} = 0.4 \text{ mA}$$

Problem 2.37

Find R_{AB} in the circuit shown.

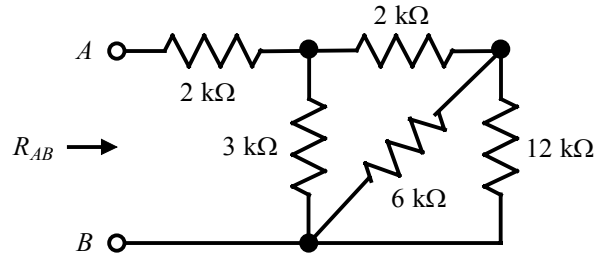

Suggested Solution

The network can be redrawn as shown below.

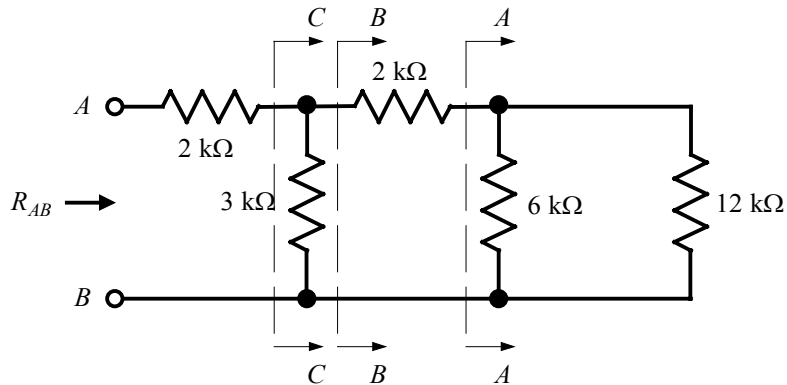

Then,

$$\text{At } A-A: 6000 \parallel 12000 = 4 \text{ k}\Omega$$

$$\text{At } B-B: 2000 + 4000 = 6 \text{ k}\Omega$$

$$\text{At } C-C: 3000 \parallel 6000 = 2 \text{ k}\Omega$$

and

$$R_{AB} = 2000 + 2000 = 4 \text{ k}\Omega$$

Problem 2.38

Find R_{AB} in the circuit shown.

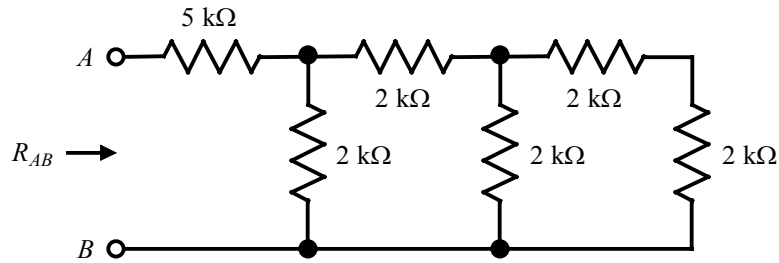

Suggested Solution

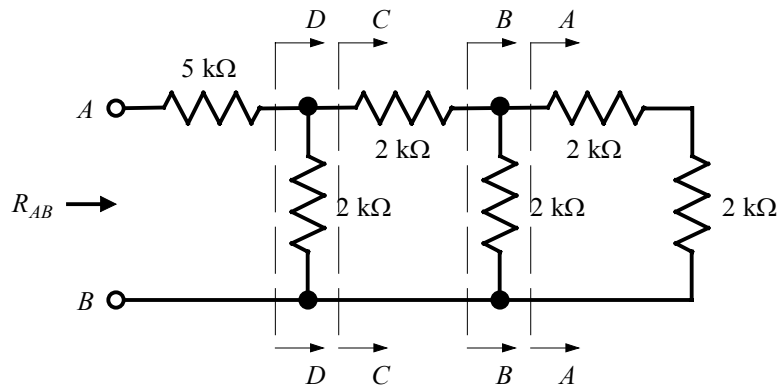

At A-A: $2000 + 2000 = 4 \text{ k}\Omega$

At B-B: $2000 \parallel 4000 = \frac{4}{3} \text{ k}\Omega$

At C-C: $2000 + \frac{4000}{3} = \frac{10}{3} \text{ k}\Omega$

At D-D: $2000 \parallel \frac{10000}{3} = 1250 \text{ }\Omega$

Then,

$R_{AB} = 5000 + 1250 = 6250 \text{ }\Omega$

Problem 2.39

Find R_{AB} in the network shown.

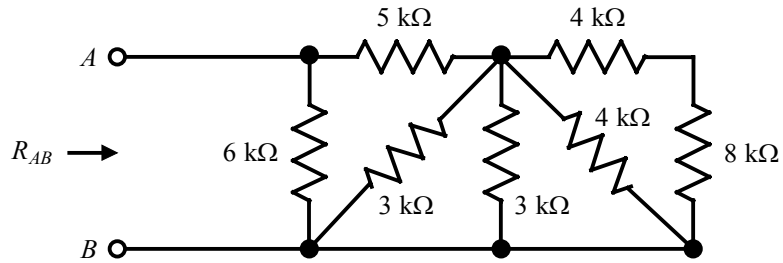

Suggested Solution

The network can be redrawn as shown below.

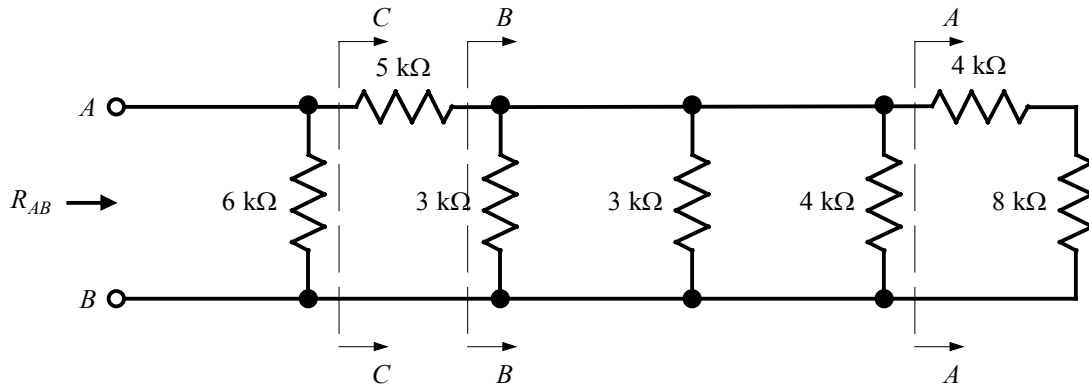

At A-A: $4000 + 8000 = 12 \text{ k}\Omega$

At B-B: $3000 \parallel 3000 \parallel 4000 \parallel 12000 = 1 \text{ k}\Omega$

At C-C: $5000 + 1000 = 6 \text{ k}\Omega$

Therefore,

$R_{AB} = 6000 \parallel 6000 = 3 \text{ k}\Omega$

Problem 2.40

Find R_{AB} in the circuit shown.

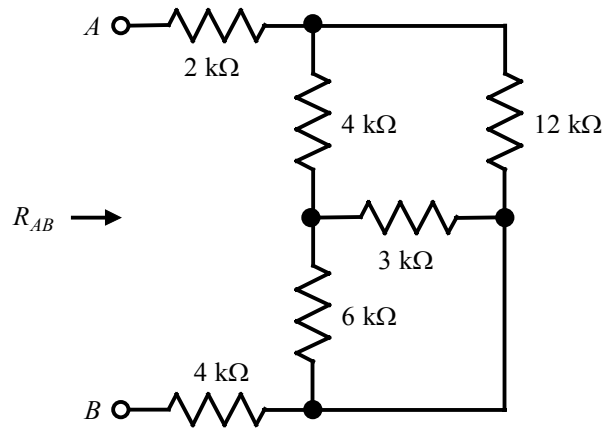

Suggested Solution

The circuit can be redrawn as shown below.

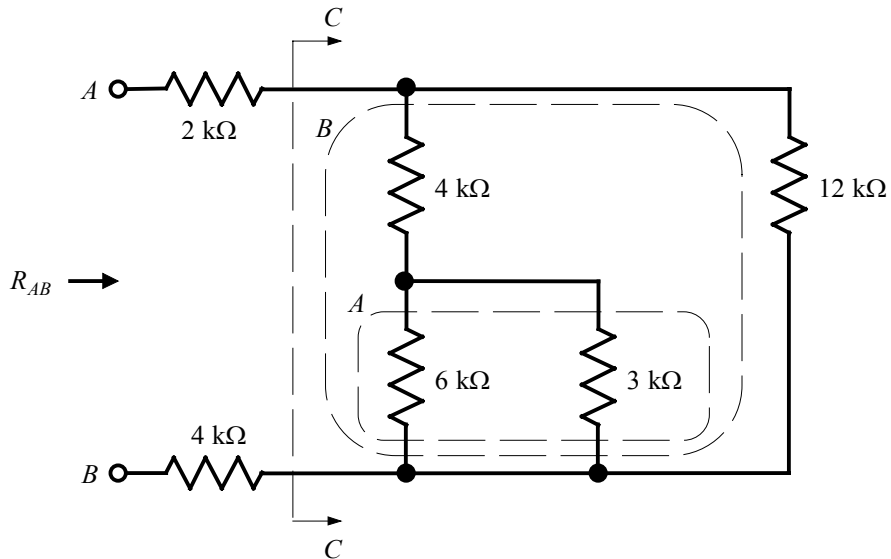

At A : $6000 \parallel 3000 = 2 \text{ k}\Omega$

At B : $4000 + 2000 = 6 \text{ k}\Omega$

At C - C : $6000 \parallel 12000 = 4 \text{ k}\Omega$

Then,

$R_{AB} = 2000 + 4000 + 4000 = 10 \text{ k}\Omega$

Problem 2.41

Find R_{AB} in the network shown.

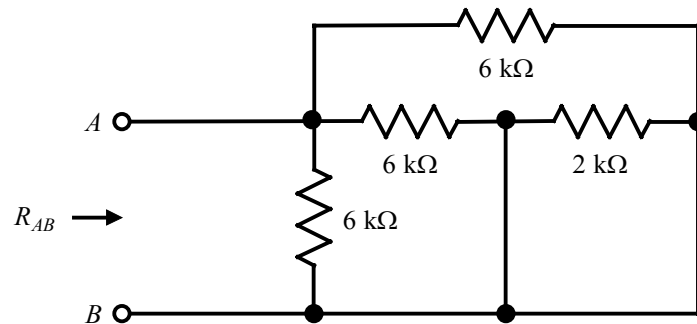

Suggested Solution

The 2-k Ω resistor is shorted. Therefore, the network reduces to:

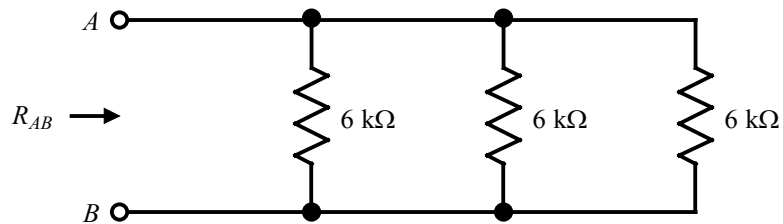

Then,

$$R_{AB} = 6000 \parallel 6000 \parallel 6000 = 2 \text{ k}\Omega$$

Problem 2.42

Find R_{AB} in the circuit shown.

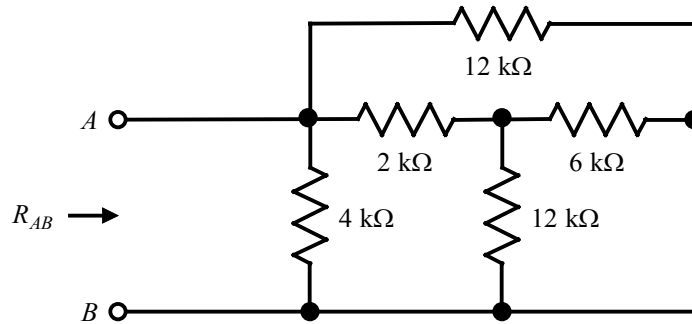

Suggested Solution

The circuit may be redrawn as follows:

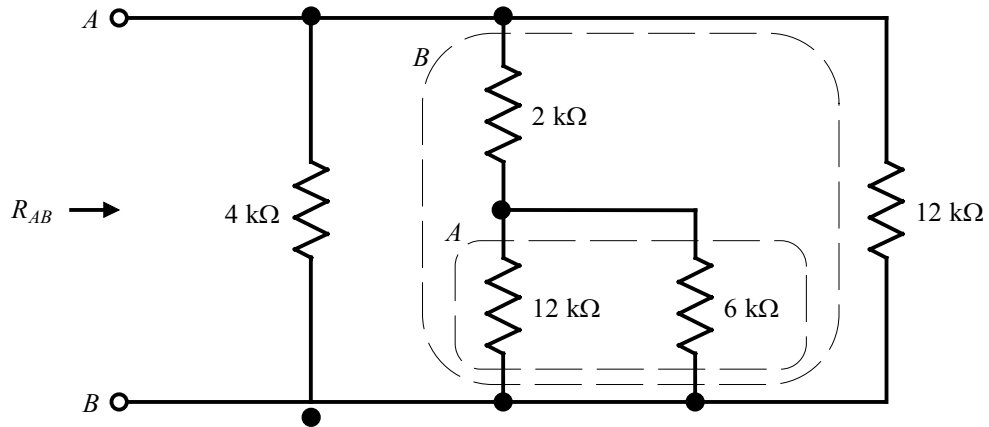

At A : $12000 \parallel 6000 = 4 \text{ k}\Omega$

At B : $2000 + 4000 = 6 \text{ k}\Omega$

Then,

$$R_{AB} = 4000 \parallel 6000 \parallel 12000 = 2 \text{ k}\Omega$$

Problem 2.43

Find R_{AB} in the circuit shown.

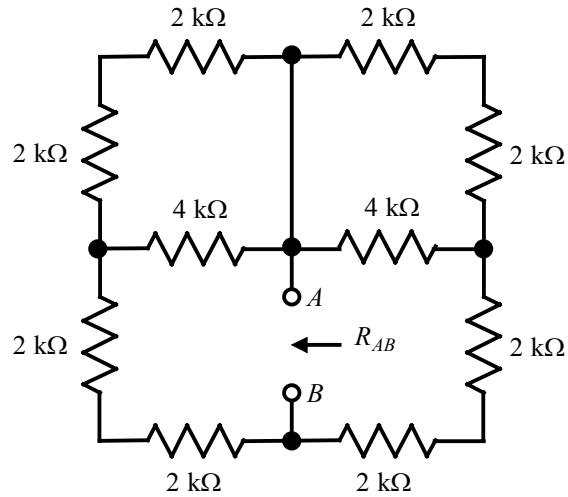

Suggested Solution

Combining each series pair of 2-k Ω resistors, the circuit can be redrawn as follows:

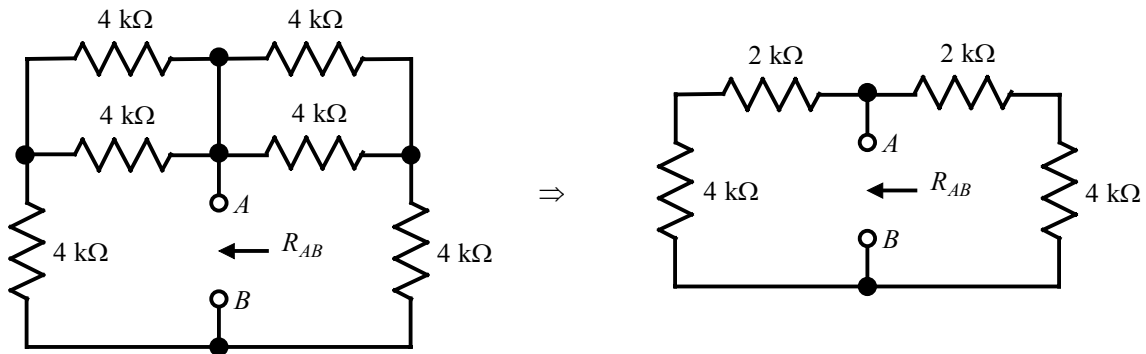

or

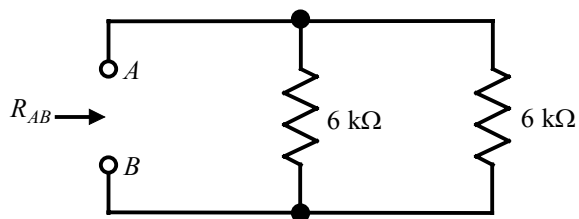

Then,

$$R_{AB} = 6000 \parallel 6000 = 3 \text{ k}\Omega$$

Problem 2.44

Find the range of resistance for the following resistors:

- a) $1 \text{ k}\Omega$ with a tolerance of 5%.
- b) $470 \text{ }\Omega$ with a tolerance of 2%.
- c) $22 \text{ k}\Omega$ with a tolerance of 10%.

Suggested Solution

- a) Minimum value = $(1 - 0.05)(1 \text{ k}\Omega) = 950 \text{ }\Omega$
Maximum value = $(1 + 0.05)(1 \text{ k}\Omega) = 1050 \text{ }\Omega$
- b) Minimum value = $(1 - 0.02)(470 \text{ }\Omega) = 460.6 \text{ }\Omega$
Maximum value = $(1 + 0.02)(470 \text{ }\Omega) = 479.4 \text{ }\Omega$
- c) Minimum value = $(1 - 0.1)(22 \text{ k}\Omega) = 19.8 \text{ k}\Omega$
Maximum value = $(1 + 0.1)(22 \text{ k}\Omega) = 24.2 \text{ k}\Omega$

Problem 2.45

Given the network shown, find the possible range of values for the current and power dissipated by the following resistors:

- $390\ \Omega$ with a tolerance of 1%.
- $560\ \Omega$ with a tolerance of 2%.

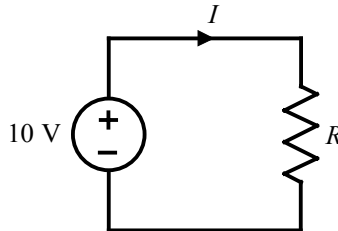

Suggested Solution

Note that $I = \frac{10\ \text{V}}{R}$ and $P = \frac{(10\ \text{V})^2}{R} = \frac{100}{R}$.

- Minimum resistor value = $(1 - 0.01)(390\ \Omega) = 386.1\ \Omega$
Maximum resistor value = $(1 + 0.01)(390\ \Omega) = 393.9\ \Omega$

$$\text{Minimum current value} = \frac{10}{393.9} = 25.39\ \text{mA}$$

$$\text{Maximum current value} = \frac{10}{386.1} = 25.90\ \text{mA}$$

$$\text{Minimum power value} = \frac{100}{393.9} = 253.9\ \text{mW}$$

$$\text{Maximum power value} = \frac{100}{386.1} = 259\ \text{mW}$$

- Minimum resistor value = $(1 - 0.02)(560\ \Omega) = 548.8\ \Omega$
Maximum resistor value = $(1 + 0.02)(560\ \Omega) = 571.2\ \Omega$

$$\text{Minimum current value} = \frac{10}{571.2} = 17.51\ \text{mA}$$

$$\text{Maximum current value} = \frac{10}{548.8} = 18.22\ \text{mA}$$

$$\text{Minimum power value} = \frac{100}{571.2} = 175.1\ \text{mW}$$

$$\text{Maximum power value} = \frac{100}{548.8} = 182.2\ \text{mW}$$

Problem 2.46

Given the circuit shown:

- Find the required value of R .
- Use Table 2.1 to select a standard 10% tolerance resistor for R .
- Calculate the actual value of I .
- Determine the percent error between the actual value of I and that shown in the circuit.
- Determine the power rating for the resistor R .

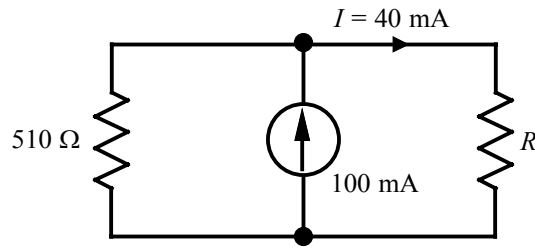

Suggested Solution

- From KCL, the current in the $510\text{-}\Omega$ resistor is $100\ \text{mA} - 40\ \text{mA} = 60\ \text{mA}$. From Ohm's Law, the voltage across the circuit is $(510\ \Omega)(60\ \text{mA}) = 30.6\ \text{V}$. Therefore, the required value of R is $(30.6\ \text{V})/(40\ \text{mA}) = 765\ \Omega$.
- From Table 2.1, the nearest 10% resistor value is $820\ \Omega$.
- To find the actual value of I , first find the actual voltage across the circuit, which is $(100\ \text{mA})(510\ \Omega \parallel 820\ \Omega) = 31.44\ \text{V}$. Then, $I = \frac{31.44\ \text{V}}{820\ \Omega} = 38.35\ \text{mA}$.
- The percent error is $\frac{(38.35 - 40)}{40}(100) = -4.14\%$.
- Since the power consumption in R is $\frac{(31.44\ \text{V})^2}{820\ \Omega} = 1.206\ \text{W}$, a 2-W resistor should be used.

Problem 2.47

The resistors R_1 and R_2 shown in the circuit are $1\ \Omega$ with a tolerance of 5% and $2\ \Omega$ with a tolerance of 10%, respectively.

- What is the nominal value of the equivalent resistance?
- Determine the positive and negative tolerance for the equivalent resistance.

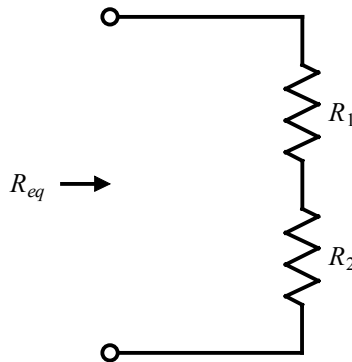

Suggested Solution

- The nominal value is $R_{eq} = R_1 + R_2 = 3\ \Omega$
- The minimum and maximum values of R_1 are $0.95\ \Omega$ and $1.05\ \Omega$, and the minimum and maximum values of R_2 are $1.8\ \Omega$ and $2.2\ \Omega$. Thus, the minimum and maximum values of R_{eq} are $0.95 + 1.8 = 2.75\ \Omega$ and $1.05 + 2.2 = 3.25\ \Omega$. The positive and negative tolerances are

$$\text{Positive Tolerance} = \frac{(3.25 - 3)}{3}(100) = 8.33\%$$

$$\text{Negative Tolerance} = \frac{(2.75 - 3)}{3}(100) = -8.33\%$$

Problem 2.48

Find I_1 and V_o in the circuit shown.

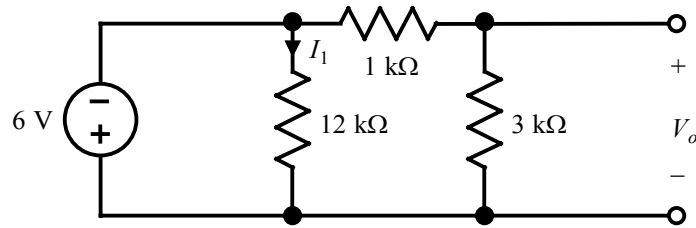

Suggested Solution

From Ohm's Law:
$$I_1 = \frac{-6 \text{ V}}{12 \text{ k}\Omega} = -0.5 \text{ mA}$$

By application of voltage division:
$$V_o = \left(\frac{3 \text{ k}\Omega}{3 \text{ k}\Omega + 1 \text{ k}\Omega} \right) (-6 \text{ V}) = -4.5 \text{ V}$$

Problem 2.49

Find I_1 and V_o in the circuit shown.

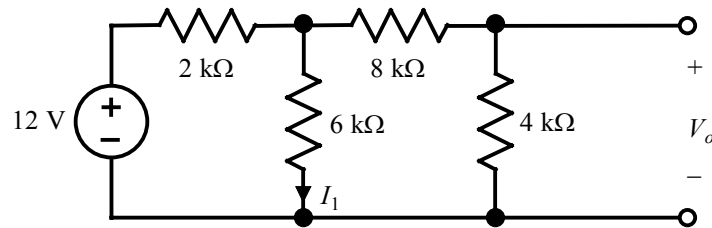

Suggested Solution

Combining resistors $[6\text{ k}\Omega \parallel (8\text{ k}\Omega + 4\text{ k}\Omega) = 4\text{ k}\Omega]$ reduces the network to the following:

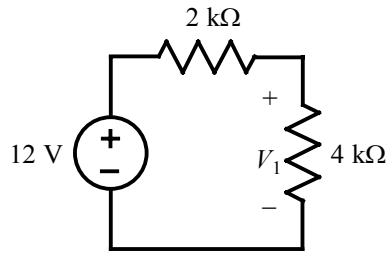

Using voltage division, then

$$V_1 = \left(\frac{4000}{2000 + 4000} \right) (12\text{ V}) = 8\text{ V} .$$

Looking back at the original circuit,

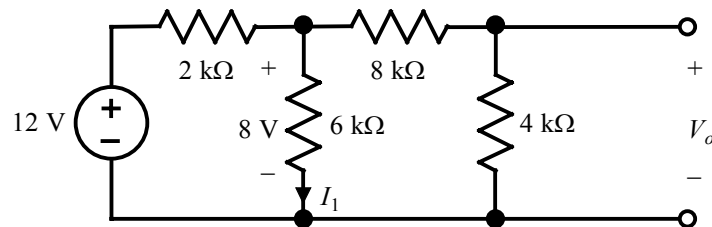

Ohm's Law:
$$I_1 = \frac{8\text{ V}}{6\text{ k}\Omega} = \frac{4}{3}\text{ mA}$$

Voltage division:
$$V_o = \left(\frac{4000}{8000 + 4000} \right) (8) = \frac{8}{3}\text{ V}$$

Problem 2.50

Find I_1 in the circuit shown.

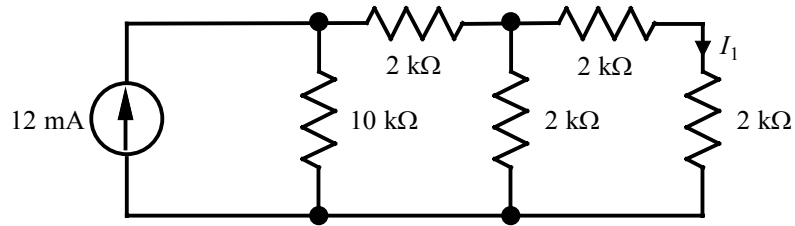

Suggested Solution

The circuit can be simplified as follows:

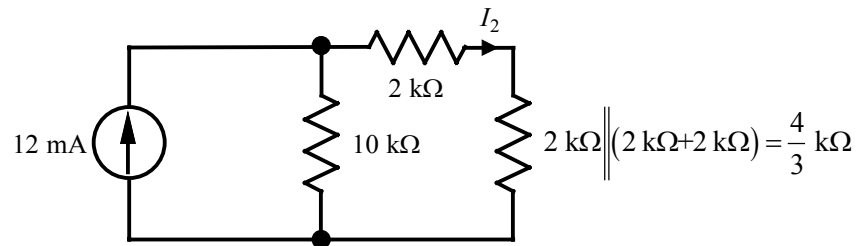

$$\text{Then, } I_2 = \left[\frac{10000}{10000 + \left(2000 + \frac{4000}{3} \right)} \right] (0.012) = 9 \text{ mA}$$

$$\text{and } I_1 = \left[\frac{2000}{2000 + (2000 + 2000)} \right] (9 \text{ mA}) = 3 \text{ mA}$$

Problem 2.51

Determine V_o in the network shown.

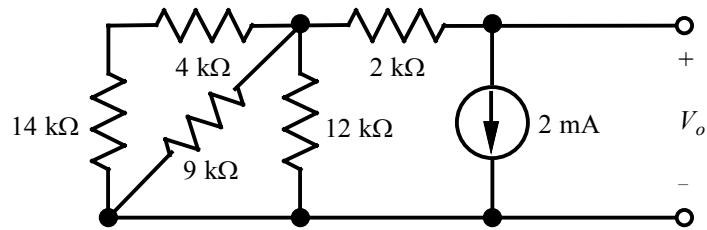

Suggested Solution

The network can be redrawn as:

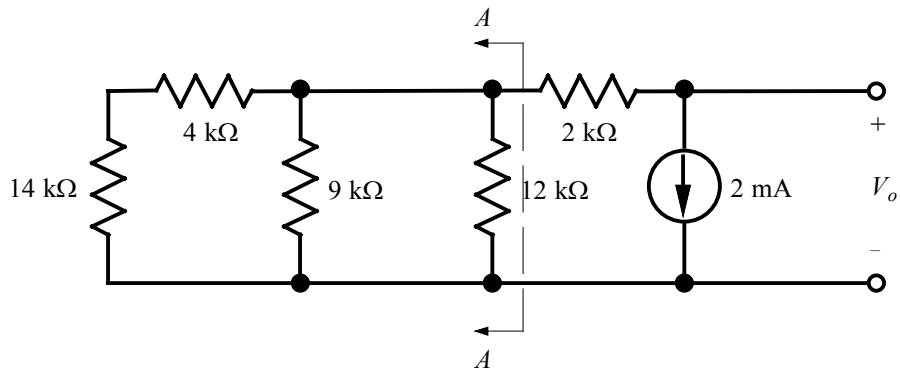

The equivalent resistance to the left of $A-A$ is $(14\text{ k}\Omega + 4\text{ k}\Omega) \parallel 9\text{ k}\Omega \parallel 12\text{ k}\Omega = 4\text{ k}\Omega$.

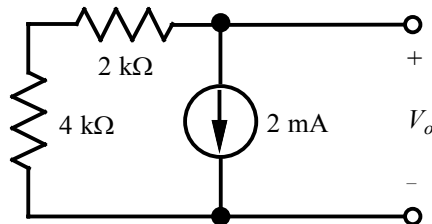

Then, $V_o = -(2\text{ k}\Omega + 4\text{ k}\Omega)(2\text{ mA}) = -12\text{ V}$.

Problem 2.52

Find V_o in the network shown.

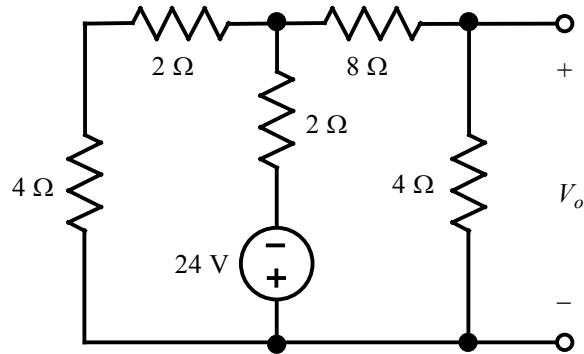

Suggested Solution

The network can be redrawn as:

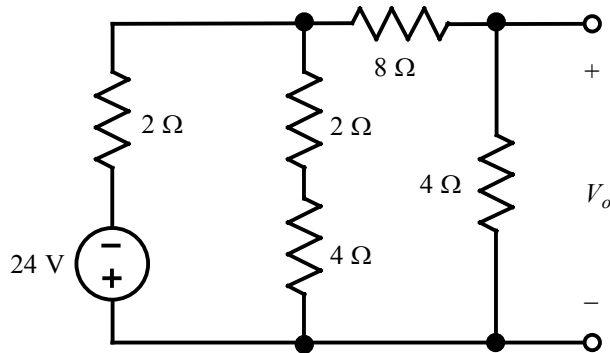

Combining the four resistors on the right-hand side $[(4\ \Omega + 2\ \Omega) \parallel (8\ \Omega + 4\ \Omega) = 4\ \Omega]$ yields:

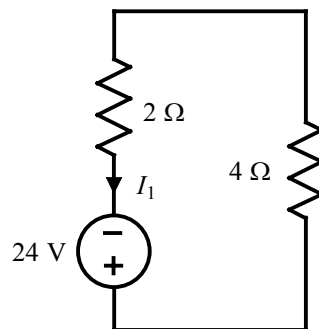

$$\text{and } I_1 = \frac{24\ \text{V}}{(2\ \Omega + 4\ \Omega)} = 4\ \text{A}.$$

Then, reconsidering the original circuit,

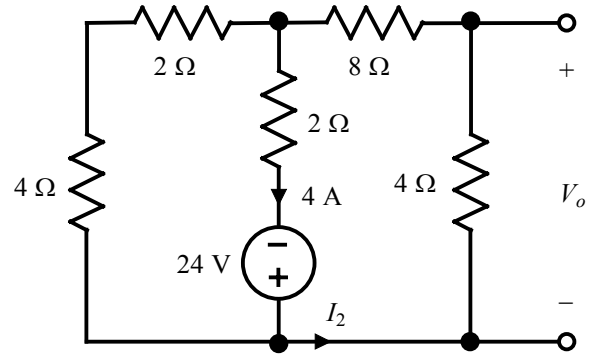

$$I_2 = \left[\frac{(4+2)}{(4+2)+(8+4)} \right] (4 \text{ A}) = \frac{4}{3} \text{ A}$$

and

$$V_o = -(4 \text{ A}) \left(\frac{4}{3} \text{ A} \right) = -\frac{16}{3} \text{ V}$$

Problem 2.53

Find I_o in the circuit shown.

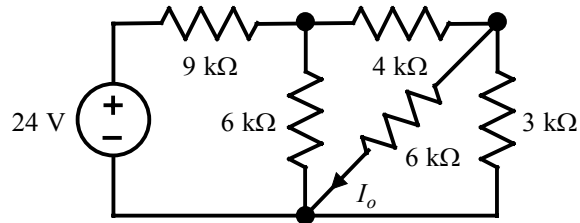

Suggested Solution

The circuit can be redrawn as:

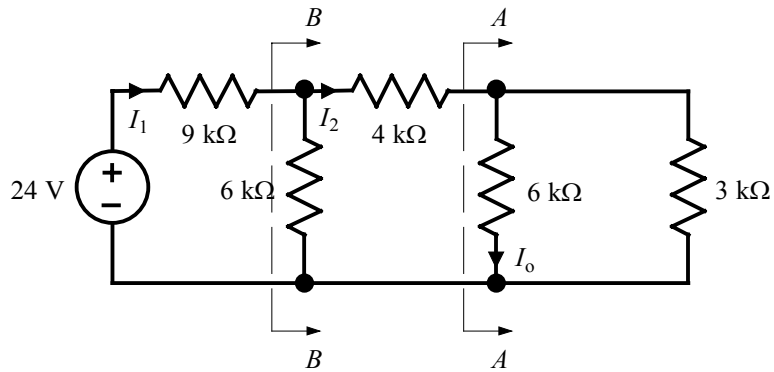

At A-A: $6000 \parallel 3000 = 2 \text{ k}\Omega$

At B-B: $6000 \parallel (4000 + 2000) = 3 \text{ k}\Omega$

The circuit simplifies to:

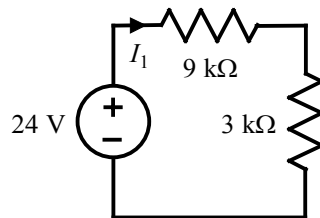

$$\text{Then, } I_1 = \frac{24}{9000 + 3000} = 2 \text{ mA} \Rightarrow I_2 = \left[\frac{6000}{6000 + (4000 + 2000)} \right] I_1 = 1 \text{ mA}$$

$$\text{and } I_o = \left(\frac{3000}{3000 + 6000} \right) I_2 = \frac{1}{3} \text{ mA} .$$

Problem 2.54

Find V_o in the circuit shown.

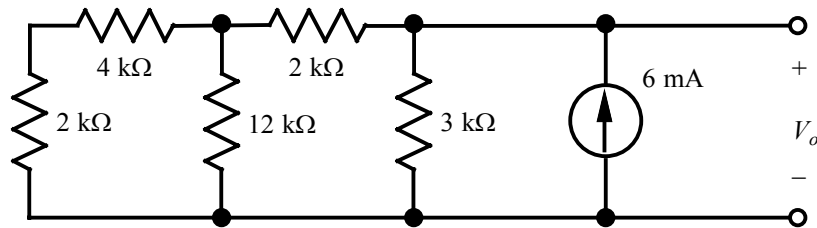

Suggested Solution

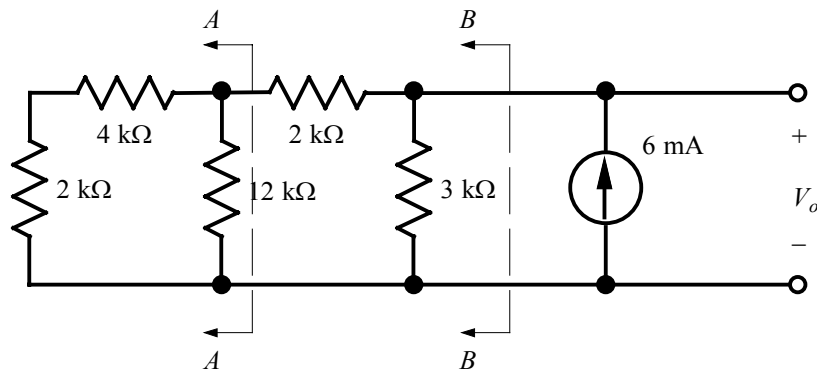

At A - A : $(2000 + 4000) \parallel 12000 = 4 \text{ k}\Omega$

At B - B : $(4000 + 2000) \parallel 3000 = 2 \text{ k}\Omega$

Then, $V_o = (2 \text{ k}\Omega)(6 \text{ mA}) = 12 \text{ V}$.

Problem 2.55

Find I_o in the network shown.

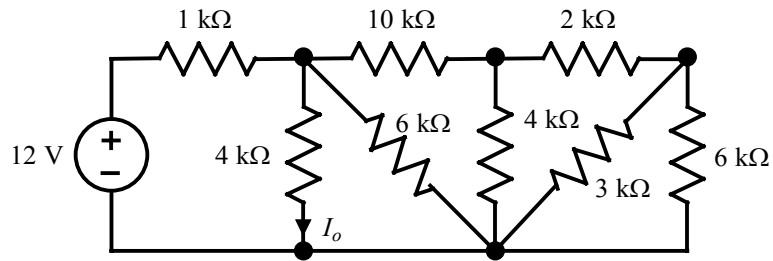

Suggested Solution

Redrawing the network:

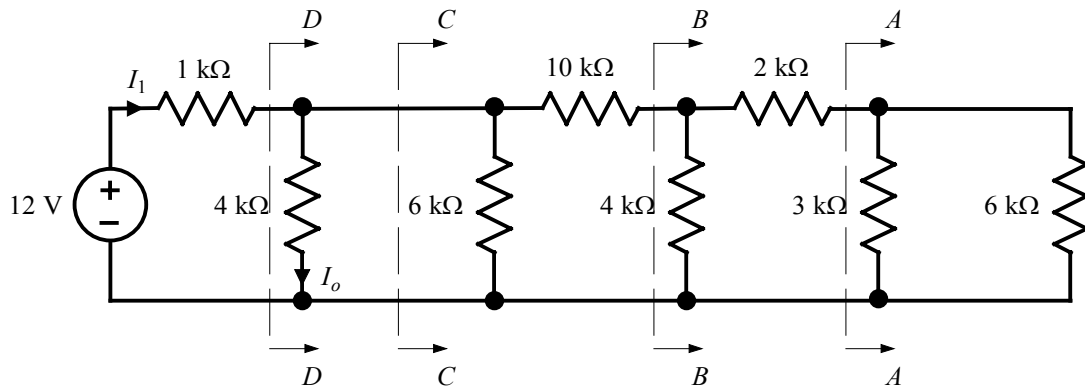

At A-A: $3000 \parallel 6000 = 2 \text{ k}\Omega$

At B-B: $4000 \parallel (2000 + 2000) = 2 \text{ k}\Omega$

At C-C: $6000 \parallel (10000 + 2000) = 4 \text{ k}\Omega$

At D-D: $4000 \parallel 4000 = 2 \text{ k}\Omega$

$$I_1 = \frac{12}{1000 + 2000} = 4 \text{ mA}$$

Using current division, $I_o = \left(\frac{4000}{4000 + 4000} \right) I_1 = 2 \text{ mA}$

Problem 2.56

Find V_o in the network shown.

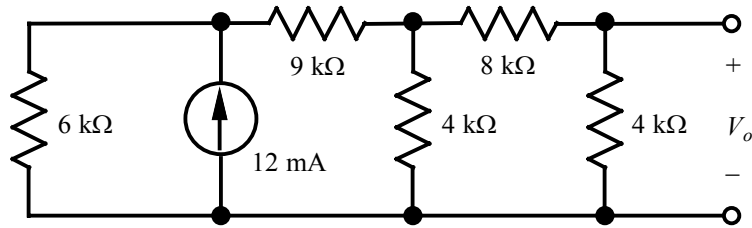

Suggested Solution

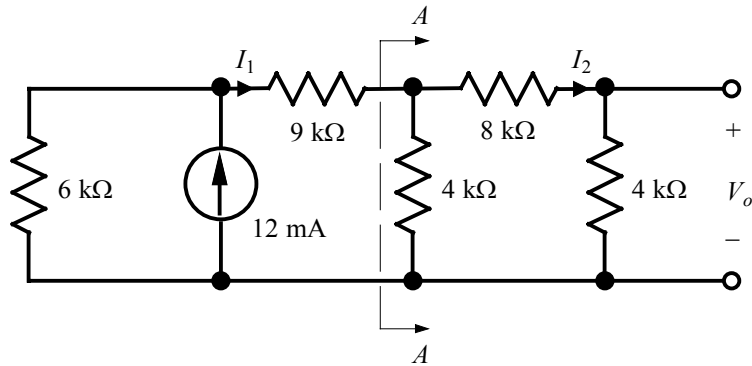

At $A-A$: $4000 \parallel (8000 + 4000) = 3 \text{ k}\Omega$

Using current division, $I_1 = \left[\frac{6000}{6000 + (9000 + 3000)} \right] 0.012 = 4 \text{ mA}$

Again using current division, $I_2 = \left[\frac{4000}{4000 + (8000 + 4000)} \right] I_1 = 1 \text{ mA}$

Then, $V_o = 4000 I_2 = 4 \text{ V}$.

Problem 2.57

Find I_o in the circuit shown.

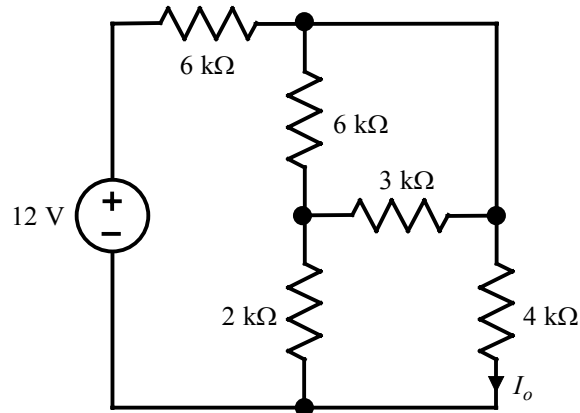

Suggested Solution

The circuit can be redrawn as:

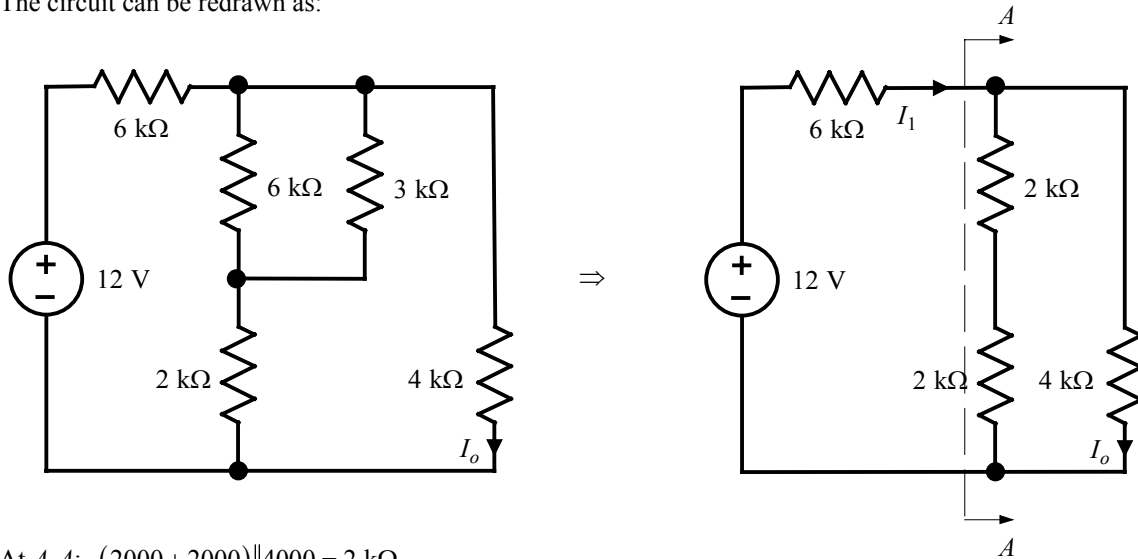

At $A-A$: $(2000 + 2000) \parallel 4000 = 2 \text{ k}\Omega$

$$I_1 = \frac{12}{6000 + 2000} = 1.5 \text{ mA}$$

Using current division, $I_o = \left[\frac{(2000 + 2000)}{(2000 + 2000) + 4000} \right] I_1 = 0.75 \text{ mA}$

Problem 2.58

If $V_o = 4\text{ V}$ in the network shown, find V_S .

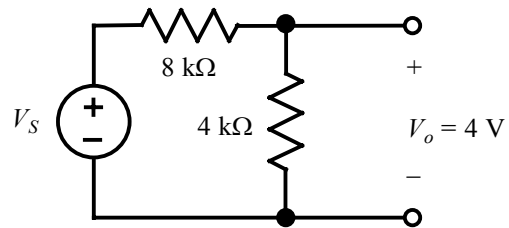

Suggested Solution

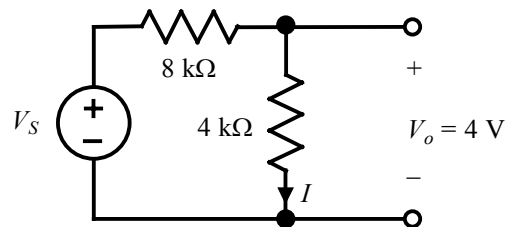

$$I = \frac{V_o}{4000} = \frac{4}{4000} = 1\text{ mA}$$

Then, $V_S = 8000I + V_o = 8 + 4 = 12\text{ V}$.

Problem 2.59

If the power absorbed by the 4-k Ω resistor in the network shown is 36 mW, find I_o .

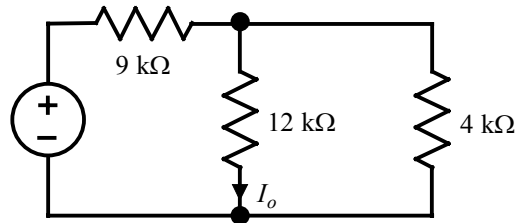

Suggested Solution

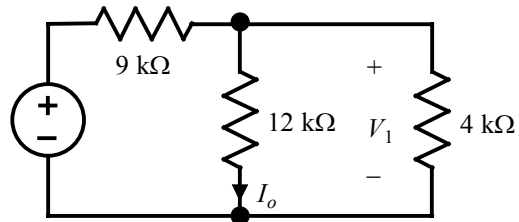

$$P_{4\text{ k}\Omega} = \frac{V_1^2}{4\text{ k}\Omega} = 36\text{ mW} \Rightarrow V_1 = 12\text{ V}$$

$$I_o = \frac{12\text{ V}}{12\text{ k}\Omega} = 1\text{ mA}$$

Problem 2.60

If the power absorbed by the 4-k Ω resistor in the circuit shown is 36 mW, find V_S .

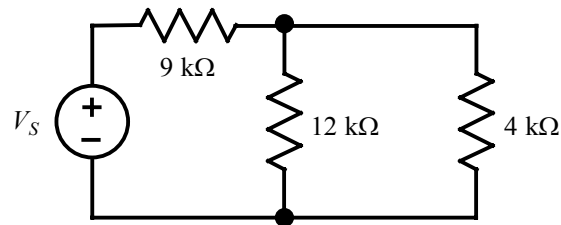

Suggested Solution

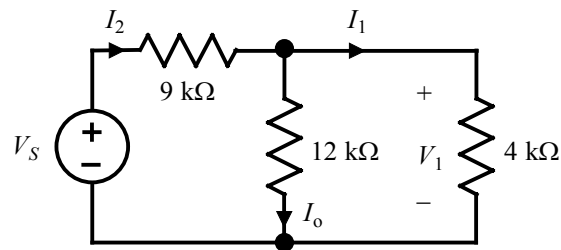

$$P_{4\text{ k}\Omega} = 36\text{ mW} = \frac{V_1^2}{4000} \Rightarrow V_1 = 12\text{ V}$$

$$I_o = \frac{V_1}{12\text{ k}\Omega} = 1\text{ mA}$$

$$I_1 = \frac{V_1}{4\text{ k}\Omega} = 3\text{ mA}$$

$$I_2 = I_o + I_1 = 1\text{ mA} + 3\text{ mA} = 4\text{ mA}$$

$$V_S = (9\text{ k}\Omega)I_2 + V_1 = 48\text{ V}$$

Problem 2.61

In the network shown, the power absorbed by the $4\text{-}\Omega$ resistor is 100 W . Find V_S .

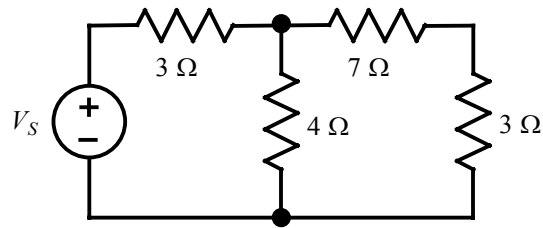

Suggested Solution

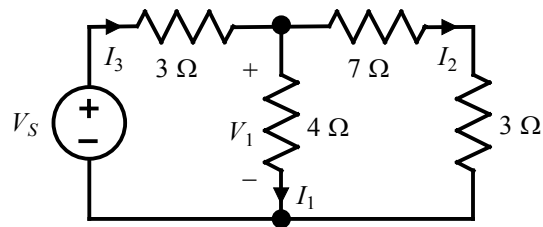

$$P_{4\Omega} = I_1^2 (4\Omega) = 100\text{ W} \Rightarrow I_1 = 5\text{ A}$$

$$V_1 = 4I_1 = 20\text{ V}$$

$$I_2 = \frac{V_1}{7\Omega + 3\Omega} = 2\text{ A}$$

$$I_3 = I_1 + I_2 = 7\text{ A}$$

$$V_S = 3I_3 + V_1 = 21 + 20 = 41\text{ V}$$

Problem 2.62

In the network shown, $V_o = 6\text{ V}$. Find I_S .

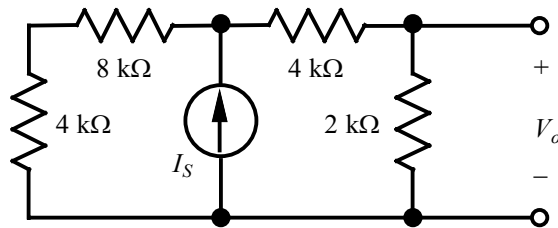

Suggested Solution

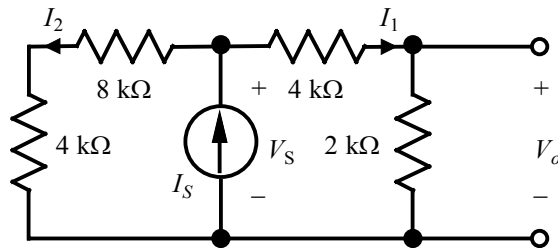

$$I_1 = \frac{V_o}{2\text{ k}\Omega} = \frac{6}{2000} = 3\text{ mA}$$

$$V_S = (4\text{ k}\Omega)I_1 + V_o = 12 + 6 = 18\text{ V}$$

$$I_2 = \frac{V_S}{8\text{ k}\Omega + 4\text{ k}\Omega} = \frac{18}{12000} = 1.5\text{ mA}$$

$$I_S = I_1 + I_2 = 3\text{ mA} + 1.5\text{ mA} = 4.5\text{ mA}$$

Problem 2.63

In the circuit shown, $I = 4 \text{ mA}$. Find V_s .

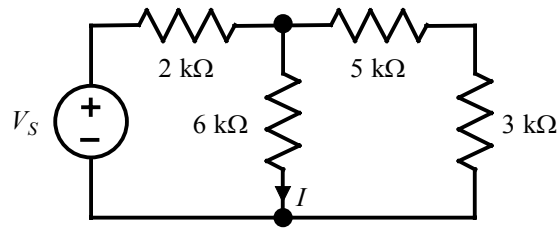

Suggested Solution

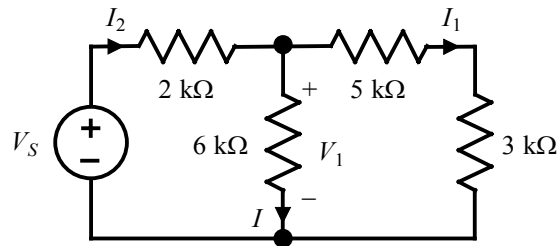

$$V_1 = (6 \text{ k}\Omega)I = 24 \text{ V}$$

$$I_1 = \frac{V_1}{5 \text{ k}\Omega + 3 \text{ k}\Omega} = \frac{24}{8000} = 3 \text{ mA}$$

$$I_2 = I + I_1 = 0.004 + 0.003 = 7 \text{ mA}$$

$$V_s = (2 \text{ k}\Omega)I_2 + V_1 = 14 + 24 = 38 \text{ V}$$

Problem 2.64

In the circuit shown, $I_o = 2 \text{ mA}$. Find I_S .

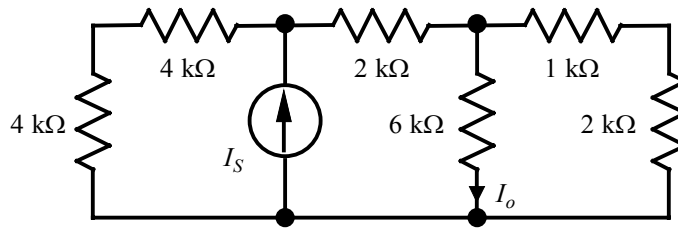

Suggested Solution

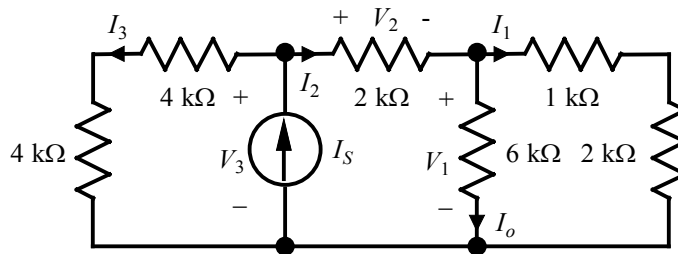

$$V_1 = (6 \text{ k}\Omega)I_o = 12 \text{ V}$$

$$I_1 = \frac{V_1}{1 \text{ k}\Omega + 2 \text{ k}\Omega} = \frac{12}{3000} = 4 \text{ mA}$$

$$I_2 = I_o + I_1 = 0.002 + 0.004 = 6 \text{ mA}$$

$$V_2 = (2 \text{ k}\Omega)I_2 = 12 \text{ V}$$

$$V_3 = V_2 + V_1 = 12 + 12 = 24 \text{ V}$$

$$I_3 = \frac{V_3}{4 \text{ k}\Omega + 4 \text{ k}\Omega} = \frac{24}{8000} = 3 \text{ mA}$$

$$I_S = I_3 + I_2 = 0.003 + 0.006 = 9 \text{ mA}$$

Problem 2.65

In the network shown, $V_1 = 12 \text{ V}$. Find V_S .

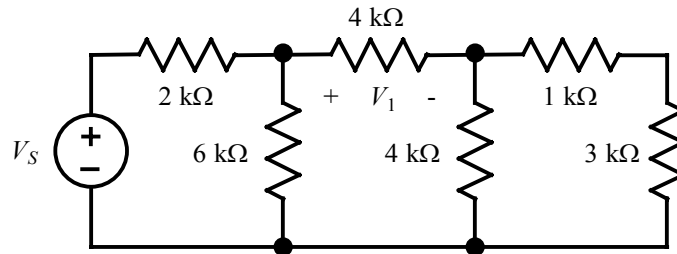

Suggested Solution

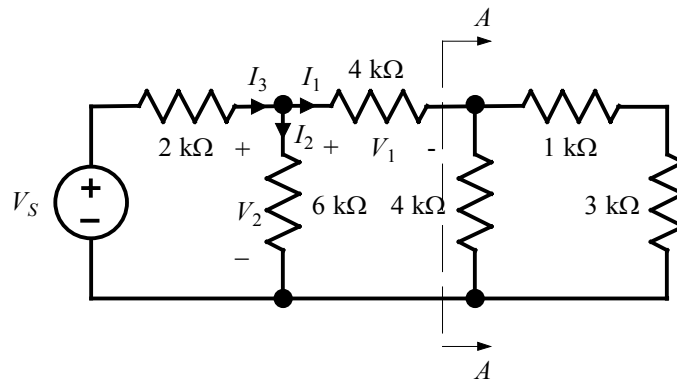

At A-A: $4000 \parallel (1000 + 3000) = 2 \text{ k}\Omega$

$$I_1 = \frac{V_1}{4 \text{ k}\Omega} = \frac{12}{4000} = 3 \text{ mA}$$

$$V_2 = V_1 + (2 \text{ k}\Omega)I_1 = 12 + 6 = 18 \text{ V}$$

$$I_2 = \frac{V_2}{6 \text{ k}\Omega} = \frac{18}{6000} = 3 \text{ mA}$$

$$I_3 = I_1 + I_2 = 0.003 + 0.003 = 6 \text{ mA}$$

$$V_S = (2 \text{ k}\Omega)I_3 + V_2 = 12 + 18 = 30 \text{ V}$$

Problem 2.66

In the circuit shown, $V_o = 2 \text{ V}$. Find I_S .

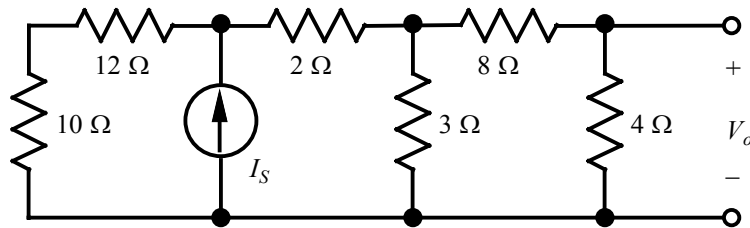

Suggested Solution

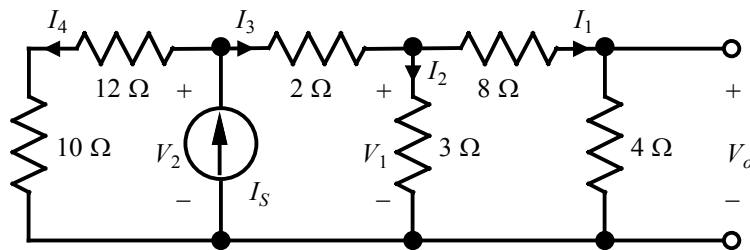

$$I_1 = \frac{V_o}{4 \Omega} = \frac{2}{4} = 0.5 \text{ A}$$

$$V_1 = (8 \Omega)I_1 + V_o = 6 \text{ V}$$

$$I_2 = \frac{V_1}{3 \Omega} = 2 \text{ A}$$

$$I_3 = I_2 + I_1 = 2.5 \text{ A}$$

$$V_2 = (2 \Omega)I_3 + V_1 = 11 \text{ V}$$

$$I_4 = \frac{V_2}{10 \Omega + 12 \Omega} = 0.5 \text{ A}$$

$$I_S = I_3 + I_4 = 2.5 + 0.5 = 3 \text{ A}$$

Problem 2.67

In the network shown, $V_o = 6\text{ V}$. Find I_S .

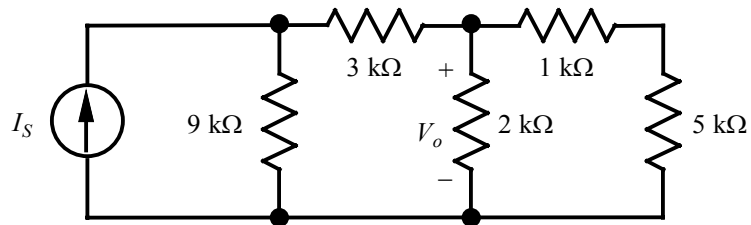

Suggested Solution

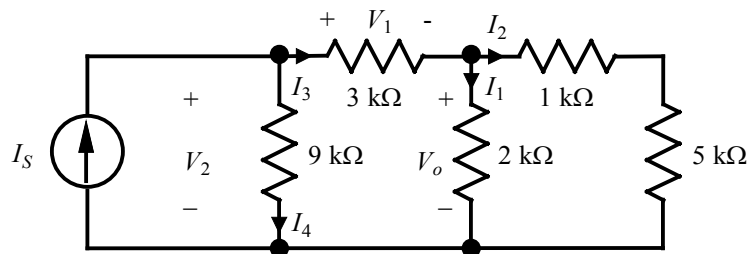

$$I_1 = \frac{V_o}{2\text{ k}\Omega} = \frac{6}{2000} = 3\text{ mA}$$

$$I_2 = \frac{V_o}{1\text{ k}\Omega + 5\text{ k}\Omega} = \frac{6}{6000} = 1\text{ mA}$$

$$I_3 = I_1 + I_2 = 0.003 + 0.001 = 4\text{ mA}$$

$$V_1 = (3\text{ k}\Omega)I_3 = 12\text{ V}$$

$$V_2 = V_1 + V_o = 12 + 6 = 18\text{ V}$$

$$I_4 = \frac{V_2}{9\text{ k}\Omega} = \frac{18}{9000} = 2\text{ mA}$$

$$I_S = I_3 + I_4 = 0.004 + 0.002 = 6\text{ mA}$$

Problem 2.68

In the circuit shown, $I_o = 2 \text{ A}$. Find I_S .

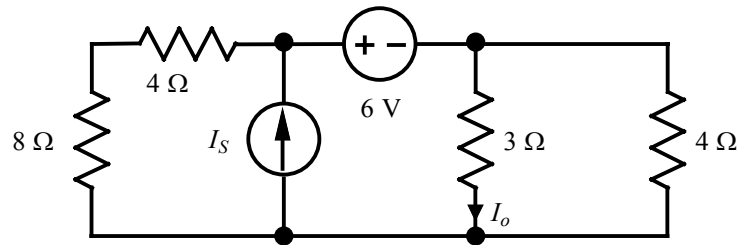

Suggested Solution

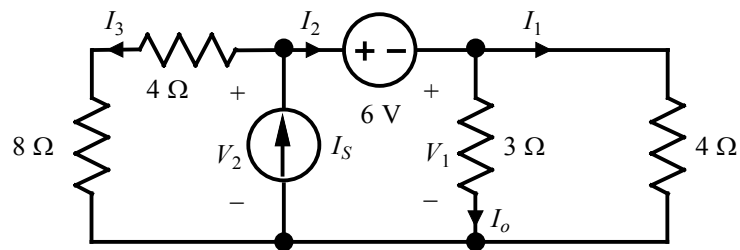

$$V_1 = (3 \Omega)I_o = 6 \text{ V}$$

$$I_1 = \frac{V_1}{4 \Omega} = \frac{6}{4} = 1.5 \text{ A}$$

$$I_2 = I_o + I_1 = 2 + 1.5 = 3.5 \text{ A}$$

$$V_2 = 6 \text{ V} + V_1 = 6 + 6 = 12 \text{ V}$$

$$I_3 = \frac{V_2}{8 \Omega + 4 \Omega} = \frac{12}{12} = 1 \text{ A}$$

$$I_S = I_2 + I_3 = 3.5 + 1 = 4.5 \text{ A}$$

Problem 2.69

If $I_o = 4 \text{ mA}$ in the circuit shown, find I_S .

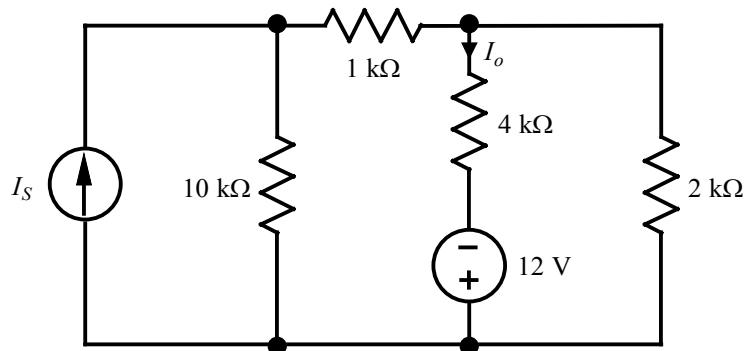

Suggested Solution

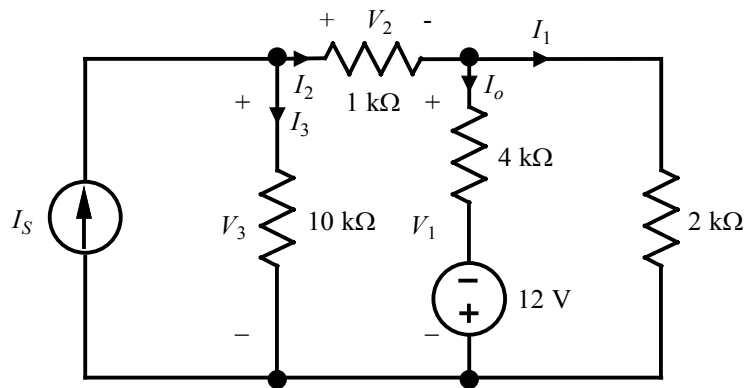

$$V_1 = (4 \text{ k}\Omega)I_o - 12 \text{ V} = 16 - 12 = 4 \text{ V}$$

$$I_1 = \frac{V_1}{2 \text{ k}\Omega} = \frac{4}{2000} = 2 \text{ mA}$$

$$I_2 = I_o + I_1 = 0.004 + 0.002 = 6 \text{ mA}$$

$$V_2 = (1 \text{ k}\Omega)I_2 = 6 \text{ V}$$

$$V_3 = V_2 + V_1 = 6 + 4 = 10 \text{ V}$$

$$I_3 = \frac{V_3}{10 \text{ k}\Omega} = \frac{10}{10000} = 1 \text{ mA}$$

$$I_S = I_2 + I_3 = 0.006 + 0.001 = 7 \text{ mA}$$

Problem 2.70

Find I_o in the circuit shown.

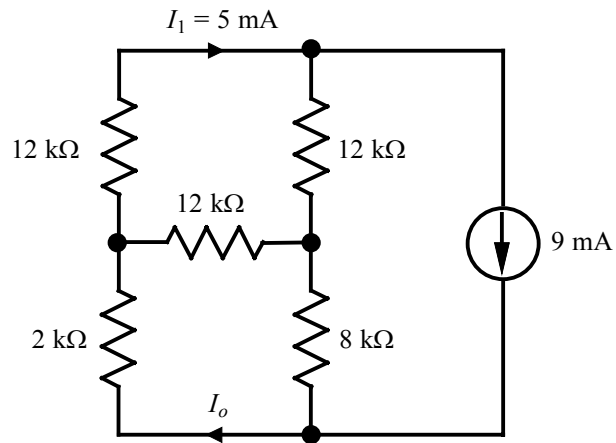

Suggested Solution

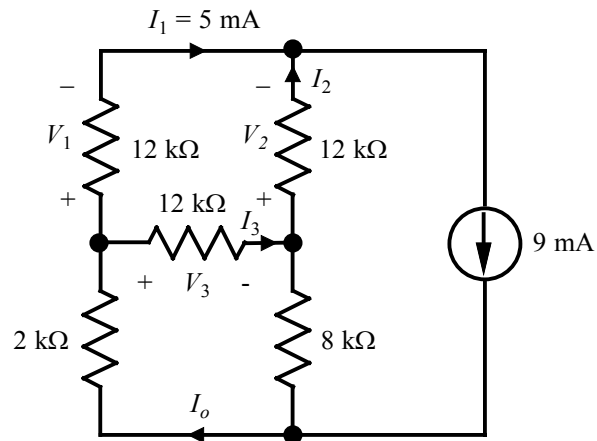

$$I_1 + I_2 = 9 \text{ mA} \quad \Rightarrow \quad I_2 = 4 \text{ mA}$$

$$V_1 = (12 \text{ k}\Omega)I_1 = 60 \text{ V}$$

$$V_2 = (12 \text{ k}\Omega)I_2 = 48 \text{ V}$$

$$V_3 = V_1 - V_2 = 60 - 48 = 12 \text{ V}$$

$$I_3 = \frac{V_3}{12 \text{ k}\Omega} = \frac{12}{12000} = 1 \text{ mA}$$

$$I_o = I_1 + I_3 = 0.005 + 0.001 = 6 \text{ mA}$$

Problem 2.71

Find V_o in the circuit shown.

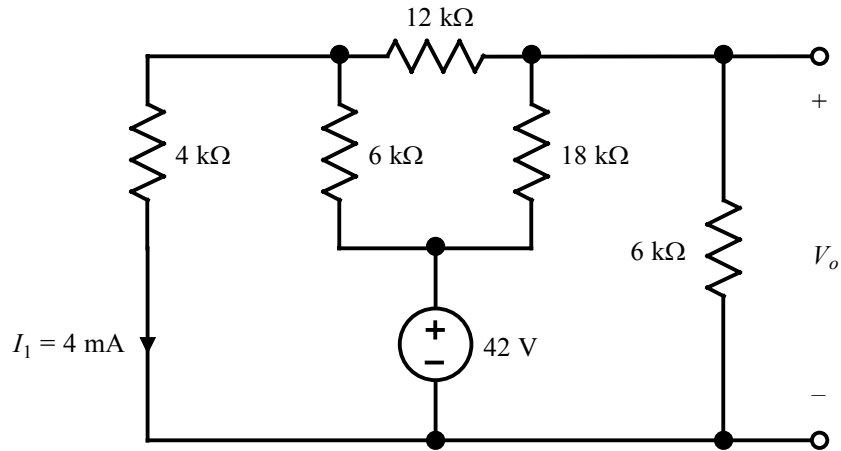

Suggested Solution

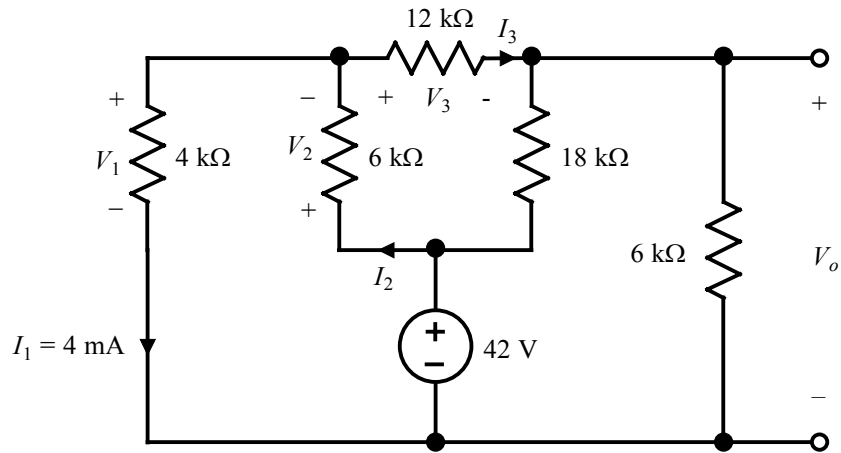

$$V_1 = (4 \text{ k}\Omega)I_1 = 16 \text{ V}$$

$$V_2 = 42 \text{ V} - V_1 = 42 - 16 = 26 \text{ V}$$

$$I_2 = \frac{V_2}{6 \text{ k}\Omega} = \frac{26}{6000} = \frac{13}{3} \text{ mA}$$

$$I_3 = I_2 - I_1 = \frac{13}{3} \text{ mA} - 4 \text{ mA} = \frac{1}{3} \text{ mA}$$

$$V_3 = (12 \text{ k}\Omega)I_3 = 4 \text{ V}$$

$$V_o = V_1 - V_3 = 16 - 4 = 12 \text{ V}$$

Problem 2.72

Find the power absorbed by the network shown.

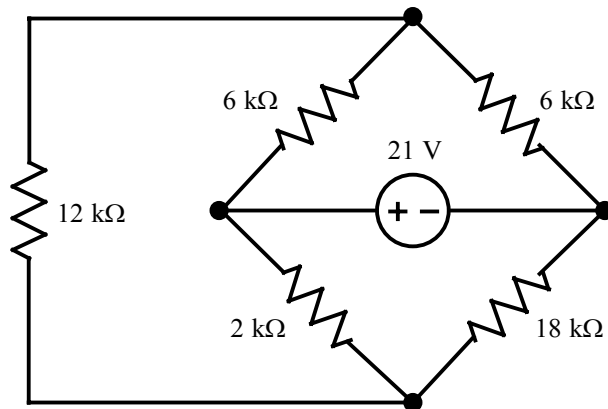

Suggested Solution

Redrawing the network:

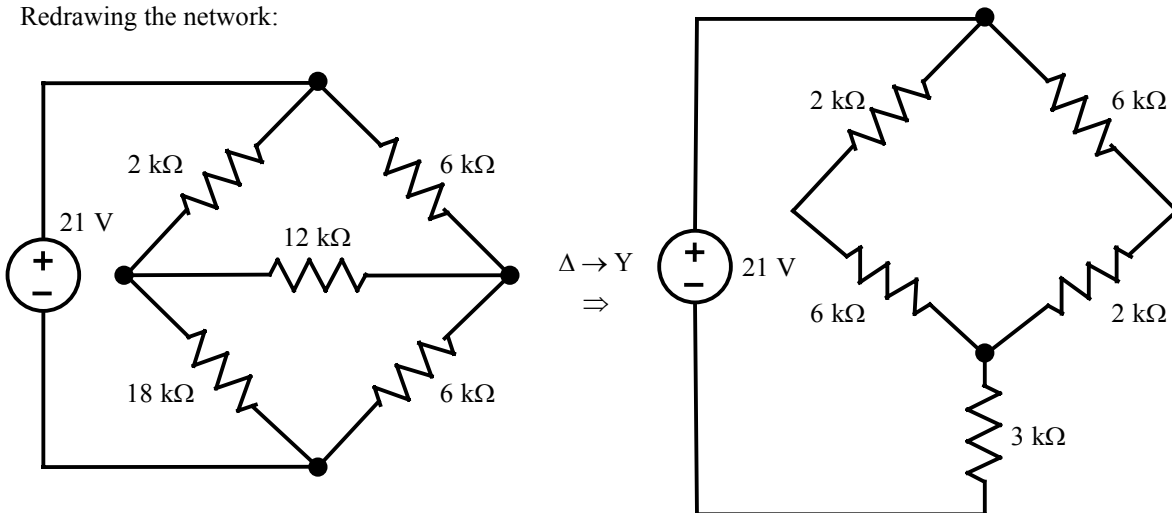

The equivalent resistance seen by the source is:

$$\begin{aligned}
 R_{eq} &= [(2 \text{ k}\Omega + 6 \text{ k}\Omega) \parallel (6 \text{ k}\Omega + 2 \text{ k}\Omega)] + 3 \text{ k}\Omega \\
 &= 4 \text{ k}\Omega + 3 \text{ k}\Omega \\
 &= 7 \text{ k}\Omega
 \end{aligned}$$

Then,

$$P = \frac{(21 \text{ V})^2}{R_{eq}} = \frac{441}{7000} = 63 \text{ mW}$$

Problem 2.73

Find I_o in the circuit shown.

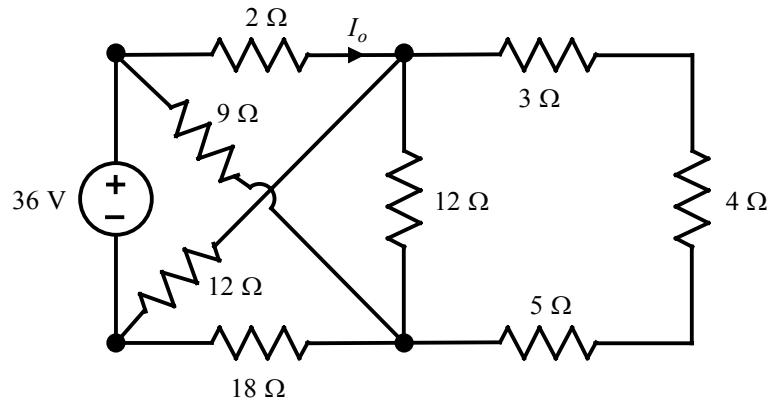

Suggested Solution

Note that the four right-most resistors can be combined as $(3\ \Omega + 4\ \Omega + 5\ \Omega) \parallel 12\ \Omega = 6\ \Omega$. Then the circuit can be redrawn as:

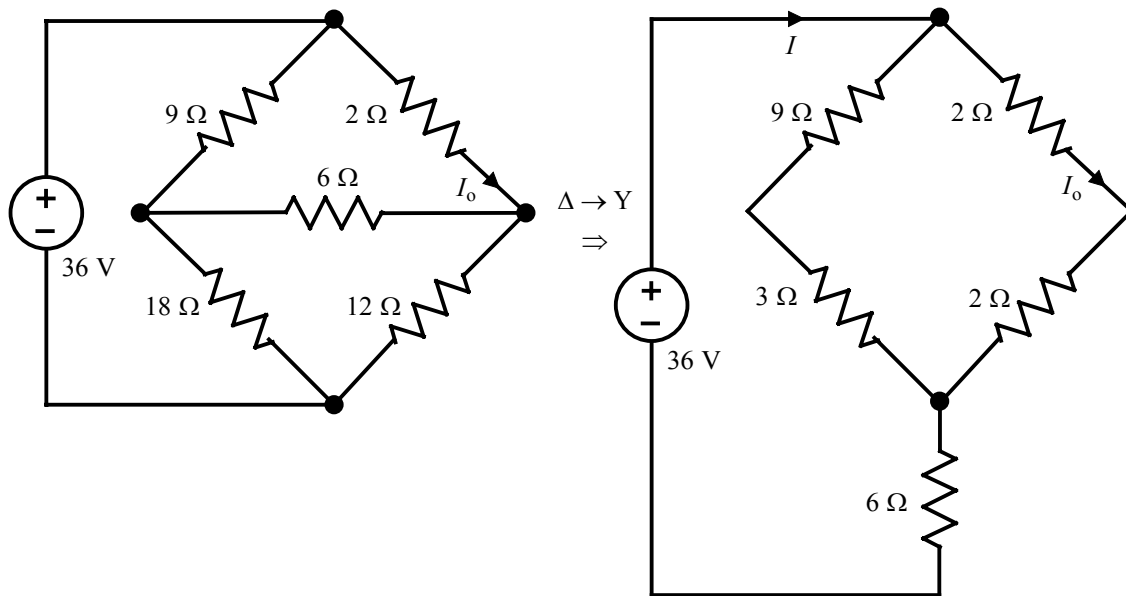

$$I = \frac{36\text{ V}}{[(9\ \Omega + 3\ \Omega) \parallel (2\ \Omega + 2\ \Omega)] + 6\ \Omega} = 4\text{ A}$$

$$I_o = \left[\frac{(9+3)}{(9+3)+(2+2)} \right] I = 3\text{ A}$$

Problem 2.74

Find I_o in the circuit shown.

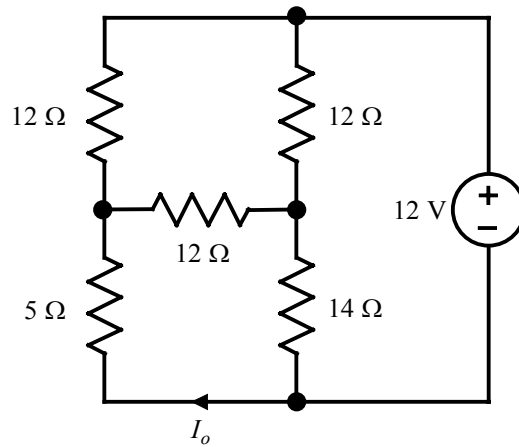

Suggested Solution

Applying the $\Delta \rightarrow Y$ transformation to the three 12- Ω resistors yields:

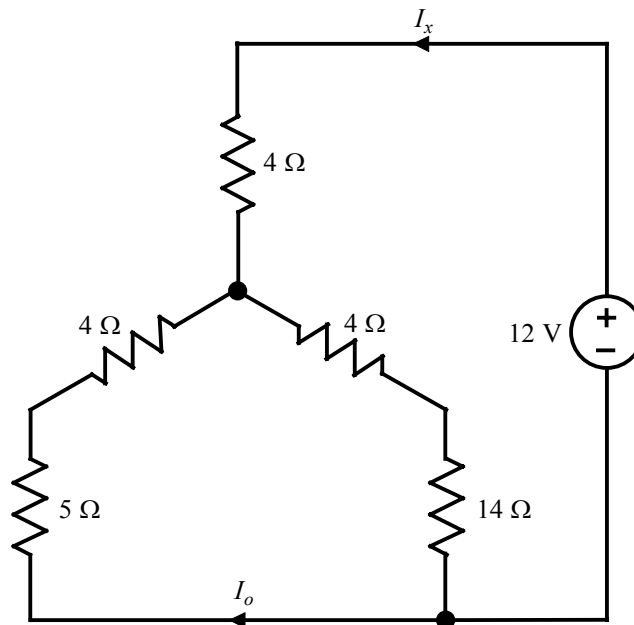

$$I_o = - \left[\frac{(4+14)}{(4+5)+(4+14)} \right] I_x \quad \text{where } I_x = \frac{12 \text{ V}}{4 \Omega + [(4 \Omega + 5 \Omega) \parallel (4 \Omega + 14 \Omega)]} = \frac{12}{10} = 1.2 \text{ A}$$

$$\therefore I_o = - \frac{18}{27} \cdot \frac{12}{10} = - \frac{4}{5} \approx -0.80 \text{ A}$$

Problem 2.75

Find I_o in the circuit shown.

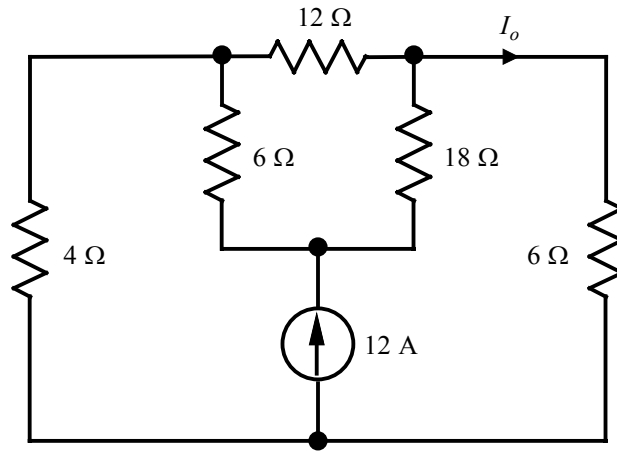

Suggested Solution

Converting the Δ to a Y yields the circuit:

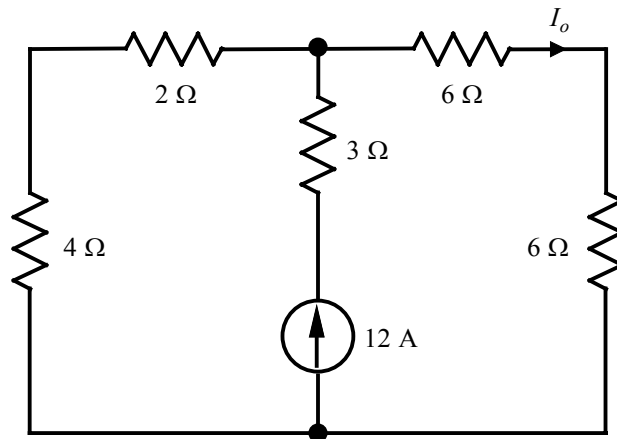

$$I_o = \left[\frac{(2+4)}{(2+4)+(6+6)} \right] (12 \text{ A}) = 4 \text{ A}$$

Problem 2.76

Find I_o in the circuit shown.

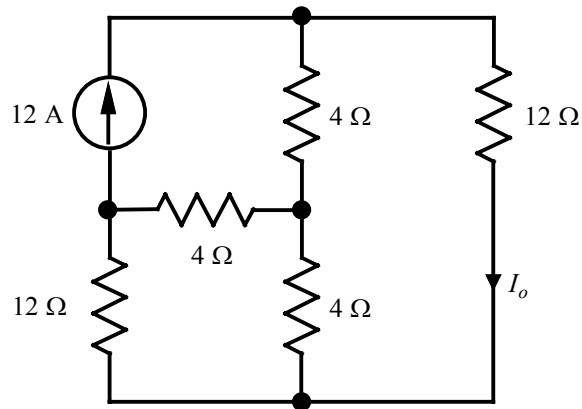

Suggested Solution

Applying the $Y \rightarrow \Delta$ transformation:

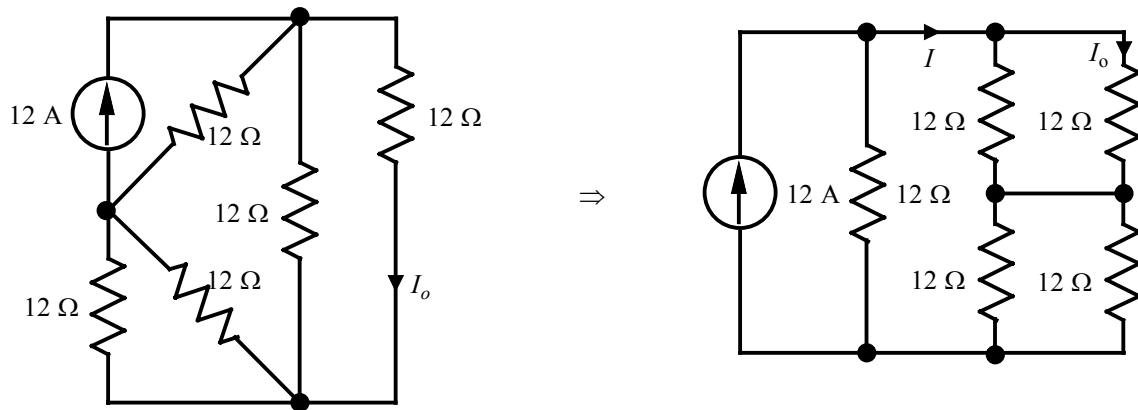

The circuit can be further simplified to:

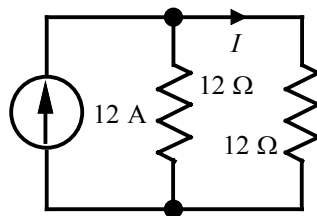

$$I = \frac{12 \text{ A}}{2} = 6 \text{ A}$$

$$I_o = \frac{I}{2} = 3 \text{ A}$$

Problem 2.77

Find I_o in the circuit shown.

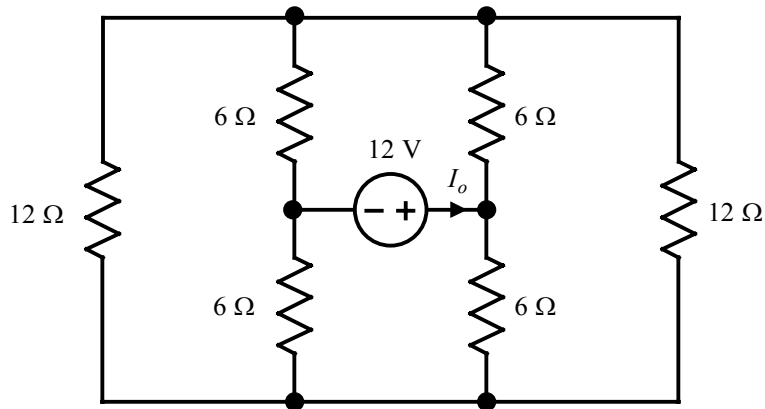

Suggested Solution

Combining the two 12-Ω resistors yields:

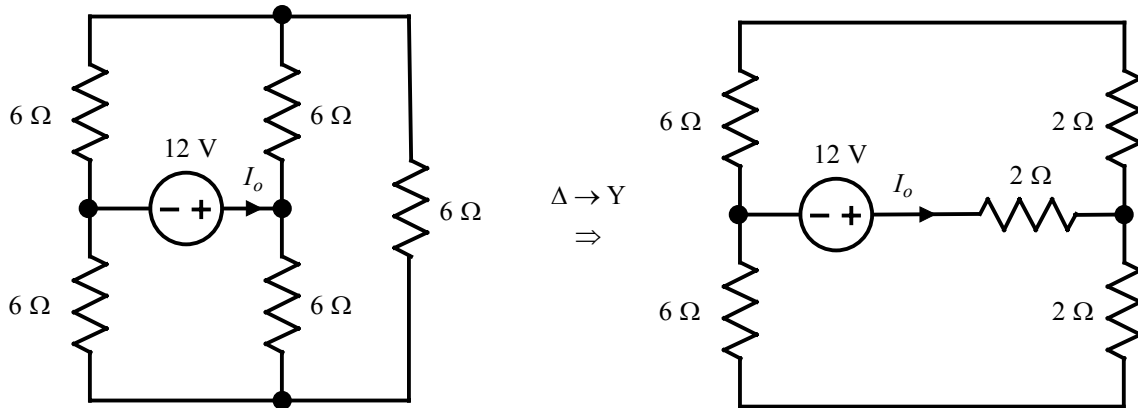

The circuit can be further simplified to the following:

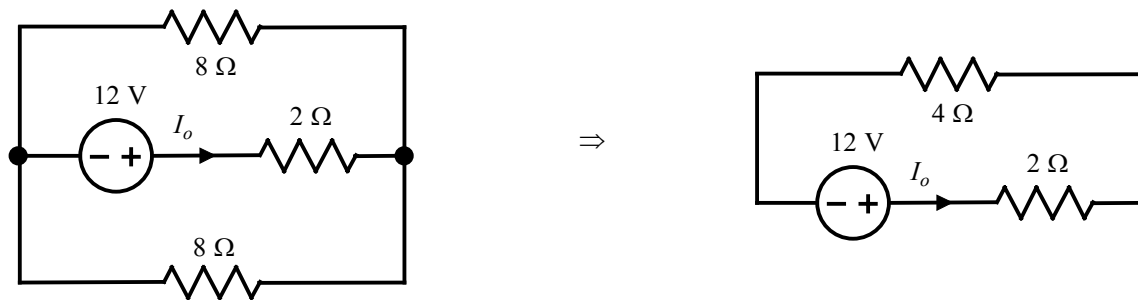

$$I_o = \frac{12 \text{ V}}{6 \Omega} = 2 \text{ A}$$

Problem 2.78

Find V_o in the circuit shown.

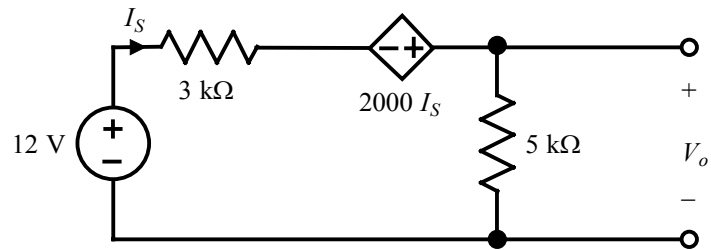

Suggested Solution

$$\text{KVL: } -12 + 3000I_S - 2000I_S + 5000I_S = 0$$

$$\Rightarrow I_S = 2 \text{ mA}$$

$$V_o = 5000I_S = 10 \text{ V}$$

Problem 2.79

Find V_o in the network shown.

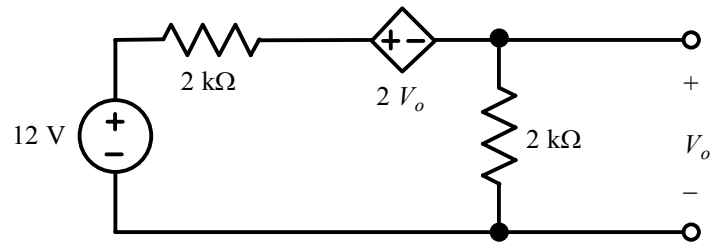

Suggested Solution

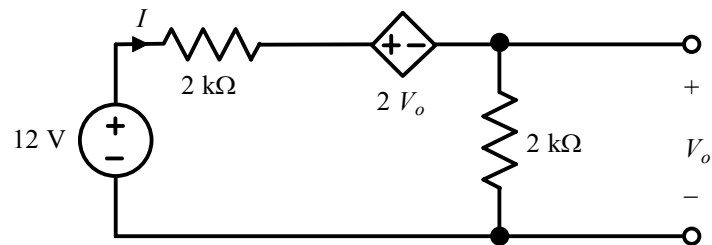

$$\text{KVL: } -12 + 2000I + 2V_o + V_o = 0 \text{ where } V_o = 2000I$$

Therefore,

$$-12 + 2000I + 4000I + 2000I = 0$$

$$\Rightarrow I = 1.5 \text{ mA}$$

$$V_o = 2000(1.5 \times 10^{-3}) = 3 \text{ V}$$

Problem 2.80

Find V_o in the network shown.

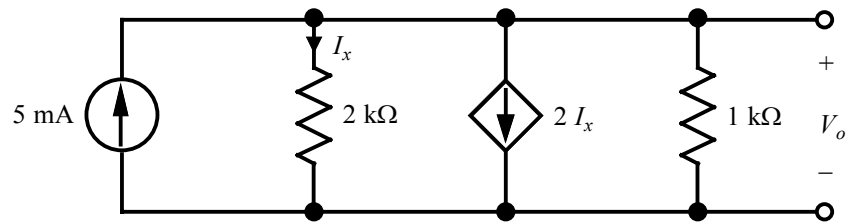

Suggested Solution

$$\text{KCL: } -0.005 + \frac{V_o}{2000} + 2I_x + \frac{V_o}{1000} = 0 \text{ where } I_x = \frac{V_o}{2 \text{ k}\Omega}$$

Therefore,

$$-0.005 + \frac{V_o}{2000} + 2\frac{V_o}{2000} + \frac{V_o}{1000} = 0 \Rightarrow V_o = 2 \text{ V}$$

Problem 2.81

Find I_o in the network shown.

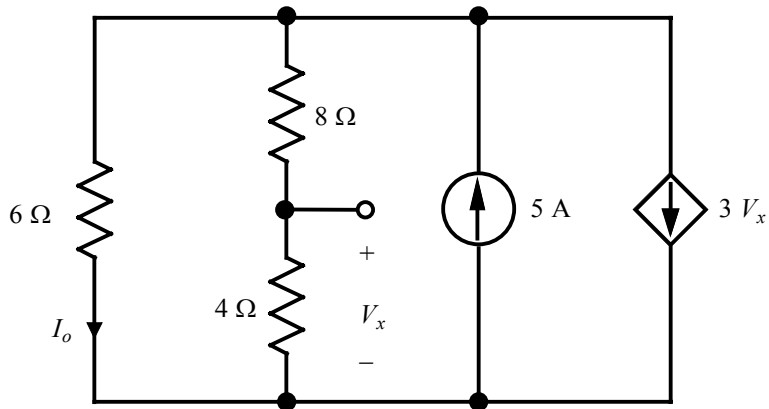

Suggested Solution

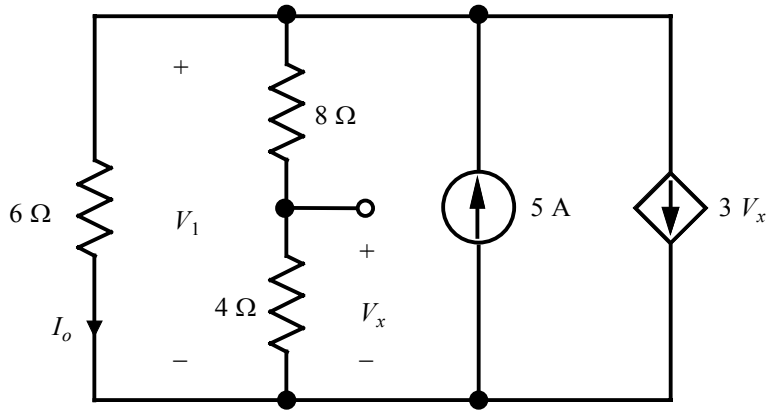

$$\text{KCL: } \frac{V_1}{6} + \frac{V_1}{8+4} - 5 + 3V_x = 0 \text{ where } V_x = \left(\frac{4}{8+4}\right)V_1 = \frac{V_1}{3}$$

Therefore,

$$\frac{V_1}{6} + \frac{V_1}{12} - 5 + 3\frac{V_1}{3} = 0$$

$$\Rightarrow V_1 = 4 \text{ V}$$

$$I_o = \frac{V_1}{6 \Omega} = \frac{4}{6} = \frac{2}{3} \text{ A}$$

Problem 2.82

Find V_o in the circuit shown.

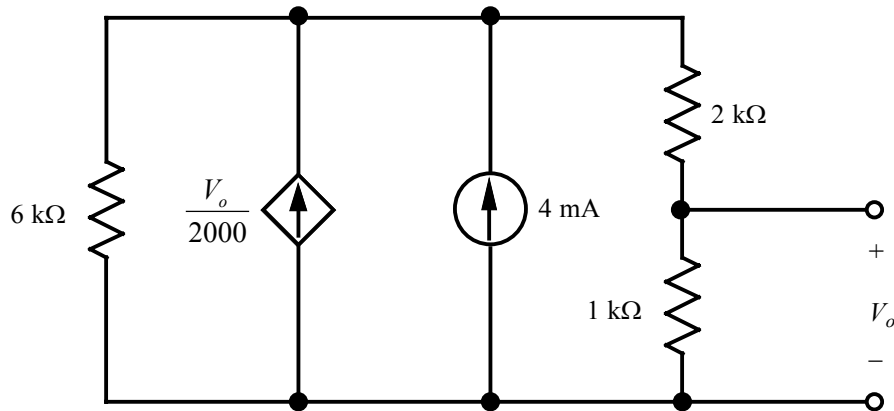

Suggested Solution

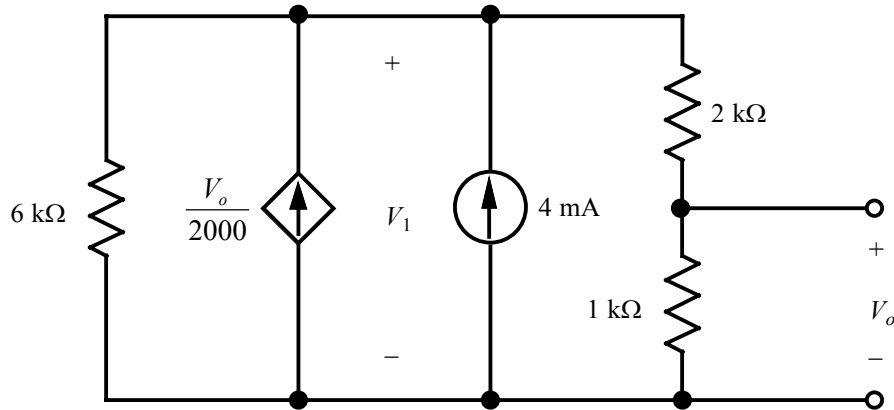

$$\text{KCL: } \frac{V_1}{6000} - \frac{V_o}{2000} - 0.004 + \frac{V_1}{2000+1000} = 0 \text{ where } V_o = \left(\frac{1000}{2000+1000} \right) V_1 = \frac{V_1}{3}$$

Therefore,

$$\frac{3V_o}{6000} - \frac{V_o}{2000} - 0.004 + \frac{3V_o}{3000} = 0$$

$$\Rightarrow V_o = 4 \text{ V}$$

Problem 2.83

A single-stage transistor amplifier is modeled as shown. Find the current in the load R_L .

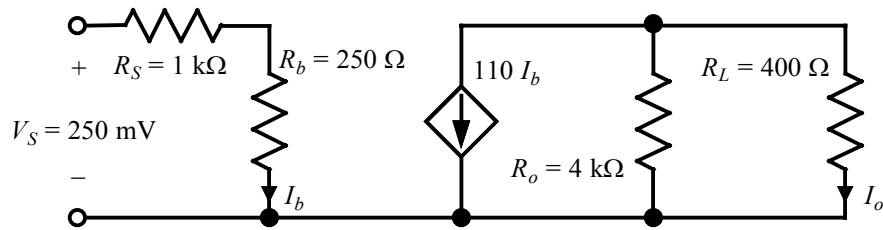

Suggested Solution

$$I_b = \frac{V_S}{R_S + R_b} = \frac{0.25}{1000 + 250} = 0.2 \text{ mA}$$

$$I_o = -\left(\frac{4000}{4000 + 400}\right)(110 I_b) = -100 I_b = -20 \text{ mA}$$

Problem 2.84

A typical transistor amplifier is shown. Find the amplifier gain G (i.e., the ratio of the output voltage to the input voltage).

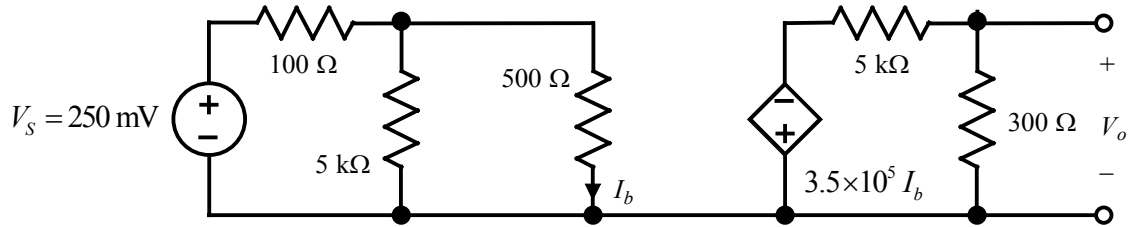

Suggested Solution

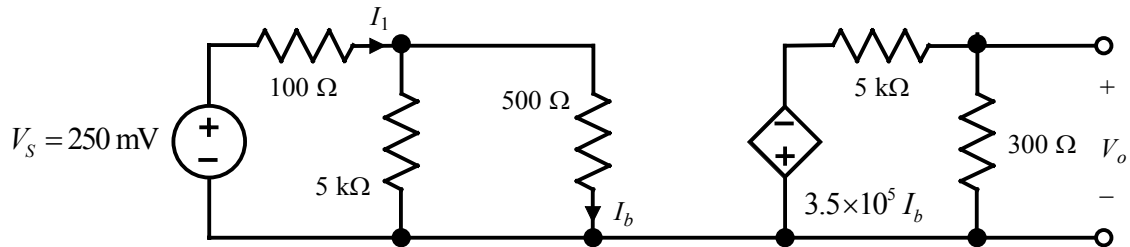

$$I_1 = \frac{V_s}{100 \Omega + (5 \text{ k}\Omega \parallel 500 \Omega)} = \frac{0.25}{554.5} = 451 \mu\text{A}$$

$$I_b = \left(\frac{5000}{5000 + 500} \right) I_1 = 409.8 \mu\text{A}$$

$$V_o = \left(\frac{300}{300 + 5000} \right) [(-3.5 \times 10^5) I_b] = -8.12 \text{ V}$$

$$G \triangleq \frac{V_o}{V_s} = \frac{-8.12}{0.250} \approx -32.5$$

Problem 2.85

For the network shown, choose the values of R_{in} and R_o such that V_o is maximized. What is the resulting ratio, V_o/V_S ?

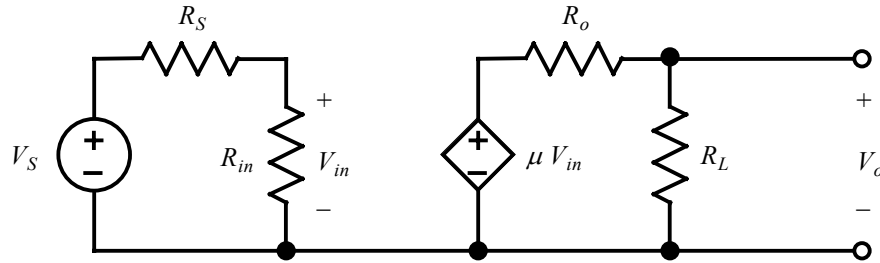

Suggested Solution

$$V_{in} = \left(\frac{R_{in}}{R_S + R_{in}} \right) V_S$$

$$V_o = \left(\frac{R_L}{R_o + R_L} \right) (\mu V_{in}) = \mu \left(\frac{R_{in}}{R_S + R_{in}} \right) \left(\frac{R_L}{R_o + R_L} \right) V_S$$

Therefore,

$$\frac{V_o}{V_S} = \mu \left(\frac{R_{in}}{R_S + R_{in}} \right) \left(\frac{R_L}{R_o + R_L} \right)$$

Clearly, to maximize $\frac{V_o}{V_S}$, we must maximize R_{in} . This is because $\frac{R_{in}}{R_S + R_{in}}$ is always less than 1, but gets closer and closer to 1 as R_{in} is made larger and larger.

On the other hand, to maximize $\frac{V_o}{V_S}$, we must minimize R_o . This is because $\frac{R_L}{R_o + R_L}$ is always less than 1, but gets closer and closer to 1 as R_o is made smaller and smaller.

In the limit,

$$\lim_{R_{in} \rightarrow \infty} \left(\lim_{R_o \rightarrow 0} \frac{V_o}{V_S} \right) = \mu \left(\lim_{R_{in} \rightarrow \infty} \frac{R_{in}}{R_S + R_{in}} \right) \left(\lim_{R_o \rightarrow 0} \frac{R_L}{R_o + R_L} \right) = \mu \times 1 \times 1 = \mu$$

Problem 2.86

In many amplifier applications we are concerned not only with voltage gain, but also with power gain.

$$\text{Power gain} = A_p = (\text{power delivered to the load}) / (\text{power delivered by the input})$$

Find the power gain for the circuit shown, where $R_L = 50 \text{ k}\Omega$.

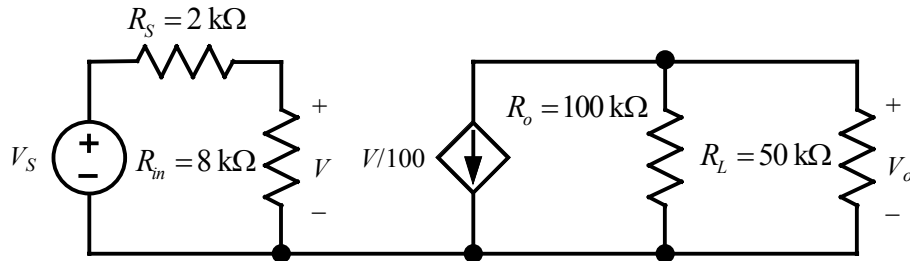

Suggested Solution

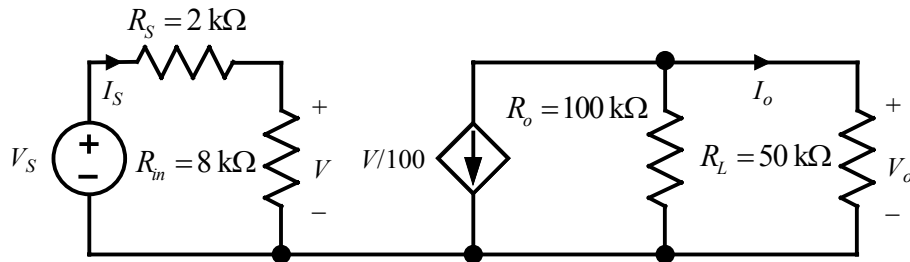

$$V = \left(\frac{8000}{8000 + 2000} \right) V_S = 0.8 V_S$$

$$I_o = - \left(\frac{100,000}{100,000 + 50,000} \right) \left(\frac{V}{100} \right) = -5.33 \times 10^{-3} V_S$$

$$P_{load} = I_o^2 R_L = (5.33 \times 10^{-3} V_S)^2 (50,000) = 1.422 V_S^2$$

$$P_{in} = V_S I_S = V_S \left(\frac{V_S}{8000 + 2000} \right) = \frac{V_S^2}{10,000}$$

$$A_p = \frac{P_{load}}{P_{in}} = \frac{1.422 V_S^2}{\left(\frac{V_S^2}{10,000} \right)} = 14.22 \times 10^3$$

Problem 2.87

Find the power absorbed by the 10-k Ω resistor in the circuit shown.

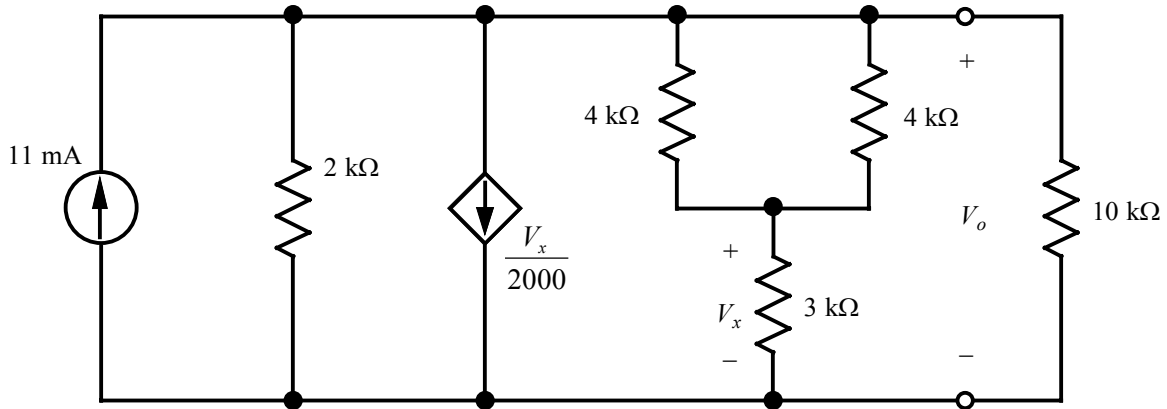

Suggested Solution

Combining the two 4-k Ω resistors in parallel yields the following simplified circuit:

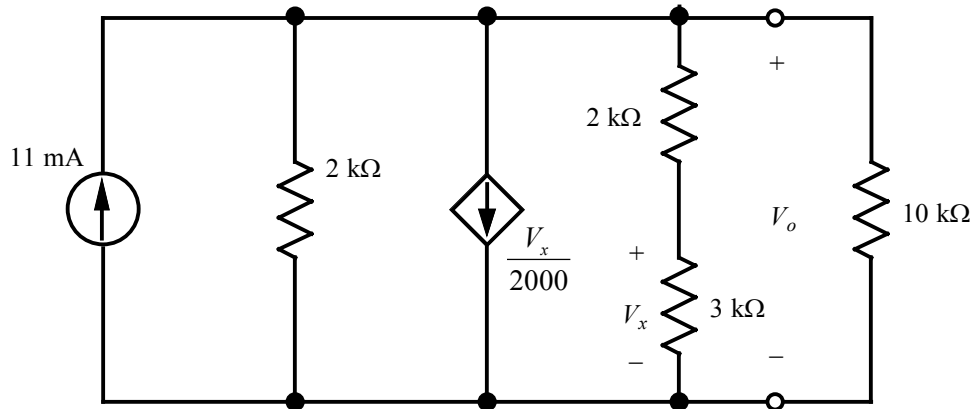

$$-0.011 + \frac{V_o}{2 \text{ k}\Omega} + \frac{V_x}{2000} + \frac{V_o}{2 \text{ k}\Omega + 3 \text{ k}\Omega} + \frac{V_o}{10 \text{ k}\Omega} = 0 \quad \text{where } V_x = \left(\frac{3000}{2000 + 3000} \right) V_o = 0.6V_o$$

Therefore,

$$-0.011 + \frac{V_o}{2000} + \frac{3V_o}{10,000} + \frac{V_o}{5000} + \frac{V_o}{10,000} = 0 \Rightarrow V_o = 10 \text{ V}$$

$$P_{10 \text{ k}\Omega} = \frac{V_o^2}{10 \text{ k}\Omega} = \frac{(10)^2}{10,000} = 10 \text{ mW}$$

Problem 2.88

Find the power absorbed by the 12-k Ω resistor in the circuit shown.

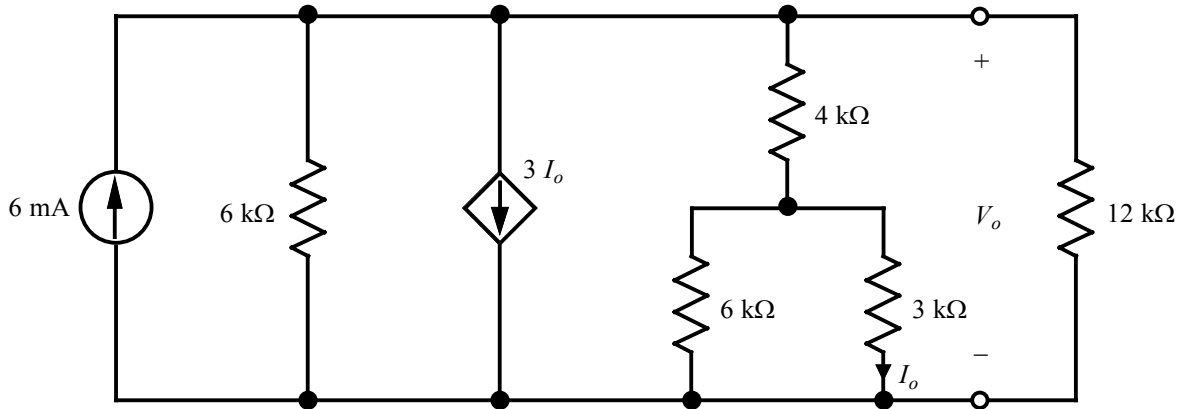

Suggested Solution

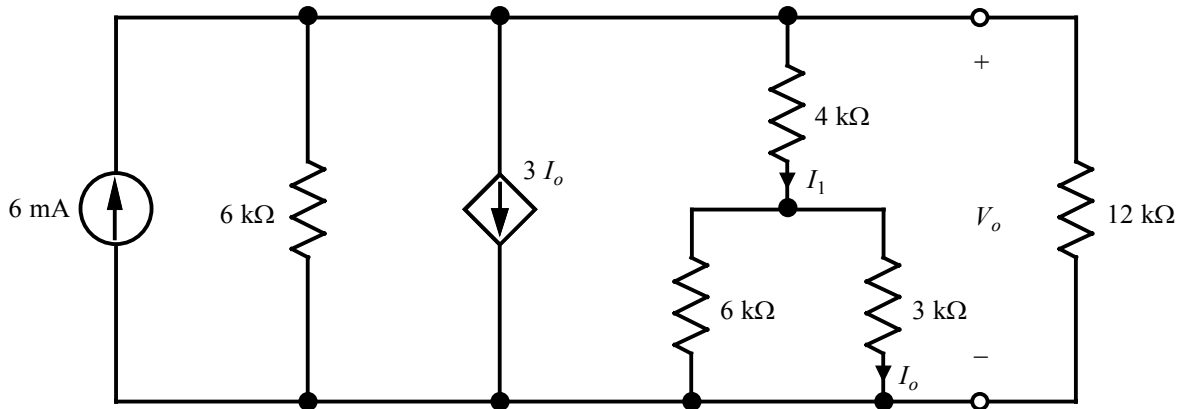

$$-0.006 + \frac{V_o}{6 \text{ k}\Omega} + 3I_o + \frac{V_o}{4 \text{ k}\Omega + (6 \text{ k}\Omega \parallel 3 \text{ k}\Omega)} + \frac{V_o}{12 \text{ k}\Omega} = 0 \quad \text{where } I_o = \left(\frac{6000}{6000 + 3000} \right) I_1 = \frac{2}{3} I_1$$

$$I_1 = \frac{V_o}{4 \text{ k}\Omega + (6 \text{ k}\Omega \parallel 3 \text{ k}\Omega)} = \frac{V_o}{6000} \Rightarrow I_o = \frac{2}{3} \left(\frac{V_o}{6000} \right) = \frac{V_o}{9000}$$

Then, substituting:

$$-0.006 + \frac{V_o}{6000} + 3 \left(\frac{V_o}{9000} \right) + \frac{V_o}{6000} + \frac{V_o}{12,000} = 0 \Rightarrow V_o = 8 \text{ V}$$

$$P_{12 \text{ k}\Omega} = \frac{V_o^2}{12 \text{ k}\Omega} = \frac{64}{12,000} = 5.33 \text{ mW}$$

Problem 2FE-1

Find the power generated by the source in the network shown.

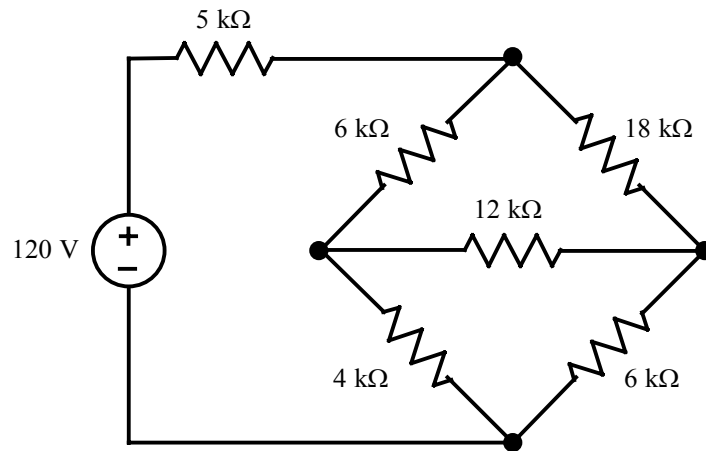

Suggested Solution

Applying the $\Delta \rightarrow Y$ transformation yields:

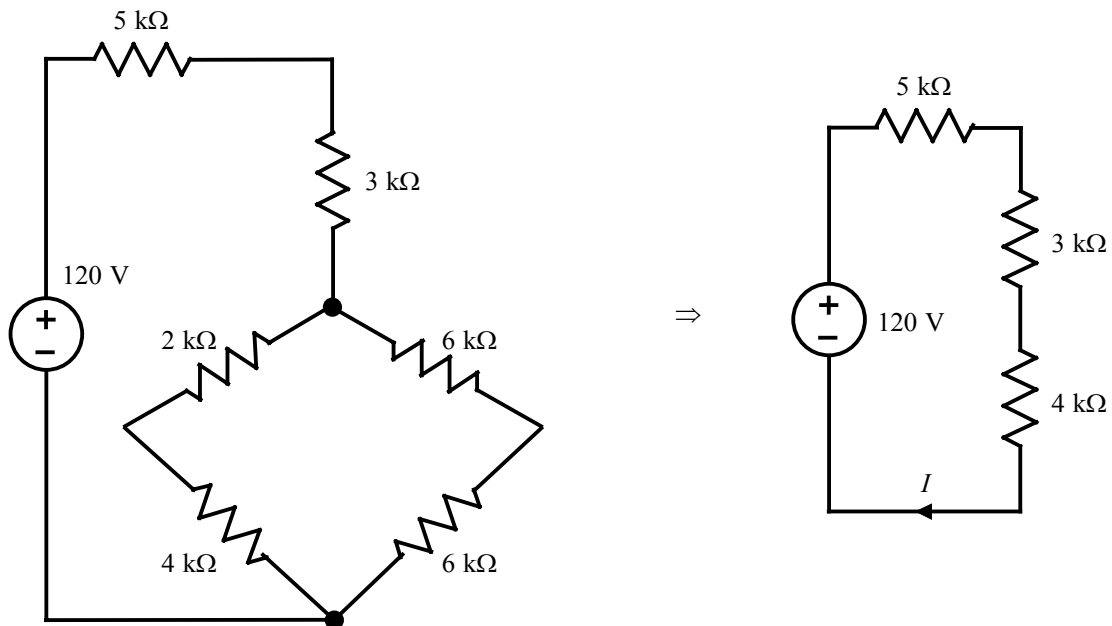

$$I = \frac{120 \text{ V}}{12 \text{ k}\Omega} = 10 \text{ mA}$$

$$P = (120 \text{ V})I = 120 \times 0.010 = 1.2 \text{ W}$$

Problem 2FE-2

Find the equivalent resistance of the circuit shown at the terminals $A-B$.

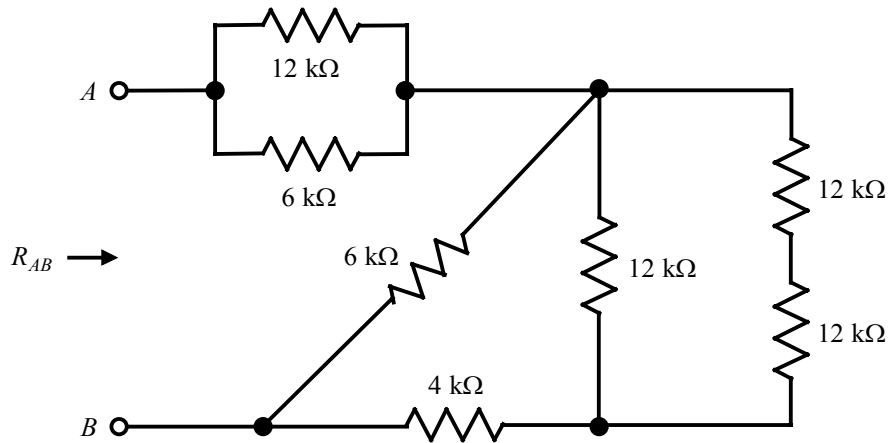

Suggested Solution

Combining resistors,

$$12 \text{ k}\Omega \parallel 6 \text{ k}\Omega = 4 \text{ k}\Omega$$

$$12 \text{ k}\Omega \parallel (12 \text{ k}\Omega + 12 \text{ k}\Omega) = 8 \text{ k}\Omega$$

The circuit is now reduced to:

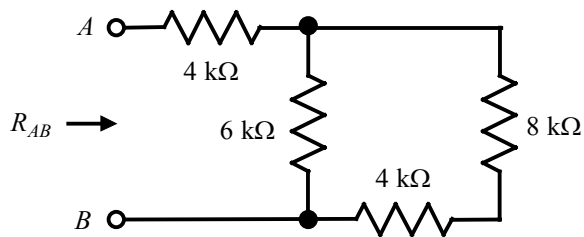

and further to:

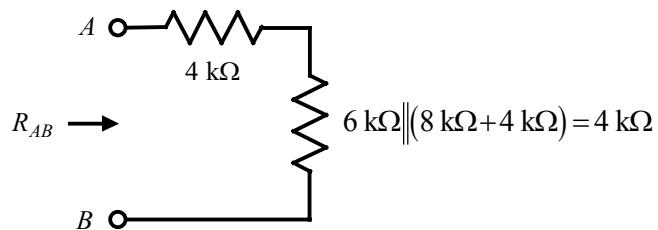

Therefore,

$$R_{AB} = 4 \text{ k}\Omega + 4 \text{ k}\Omega = 8 \text{ k}\Omega$$

Problem 2FE-3

Find the voltage V_o in the network shown.

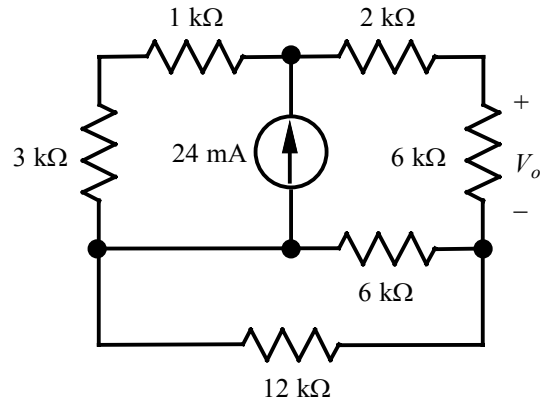

Suggested Solution

Combining resistors:

$$1 \text{ k}\Omega + 3 \text{ k}\Omega = 4 \text{ k}\Omega$$

$$6 \text{ k}\Omega \parallel 12 \text{ k}\Omega = 4 \text{ k}\Omega$$

The network is now reduced to:

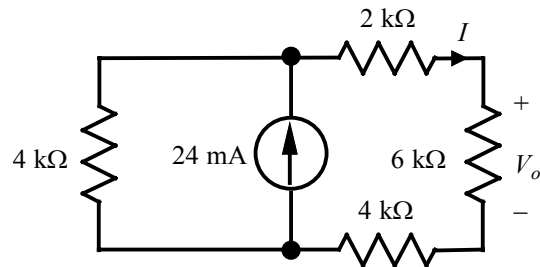

Using current division,

$$I = \left[\frac{4000}{4000 + (2000 + 6000 + 4000)} \right] (24 \text{ mA}) = 6 \text{ mA}$$

$$V_o = (6 \text{ k}\Omega) I = 36 \text{ V}$$

Problem 2FE-4

Find the current I_o in the circuit shown.

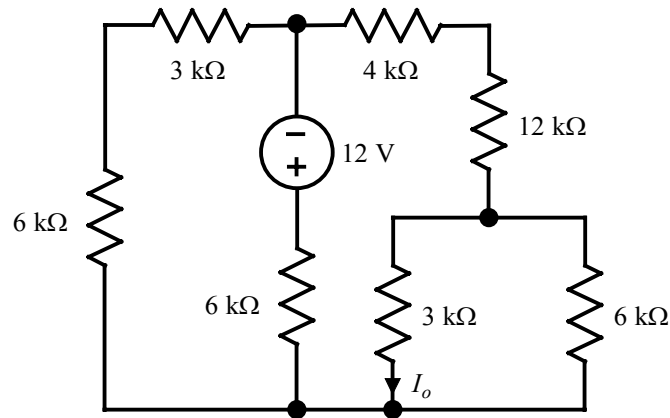

Suggested Solution

Combining resistors:

$$3 \text{ k}\Omega + 6 \text{ k}\Omega = 9 \text{ k}\Omega$$

$$3 \text{ k}\Omega \parallel 6 \text{ k}\Omega = 2 \text{ k}\Omega$$

Thus, the circuit simplifies to:

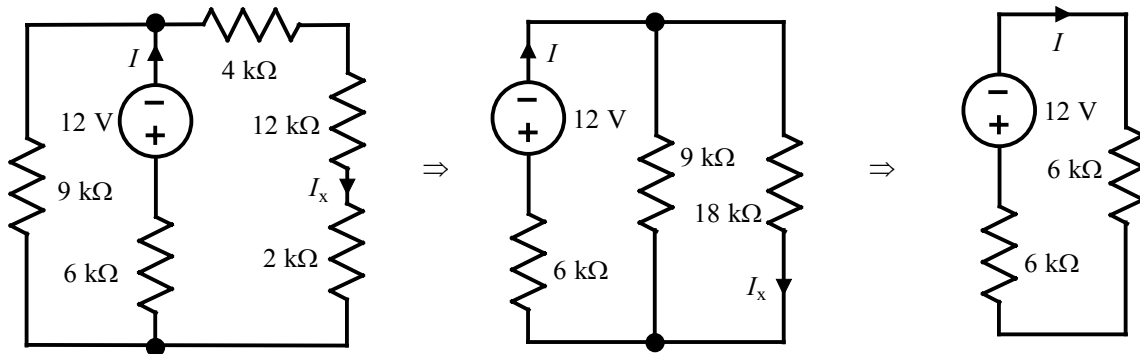

$$I = -\frac{12\text{V}}{6 \text{ k}\Omega + 6 \text{ k}\Omega} = -1 \text{ mA}$$

$$I_x = \left(\frac{9000}{9000 + 18,000} \right) I = -\frac{1}{3} \text{ mA}$$

$$I_o = \left(\frac{6000}{3000 + 6000} \right) I_x = -\frac{2}{9} \text{ mA}$$

Problem 3.1

Find I_0 in the circuit using nodal analysis.

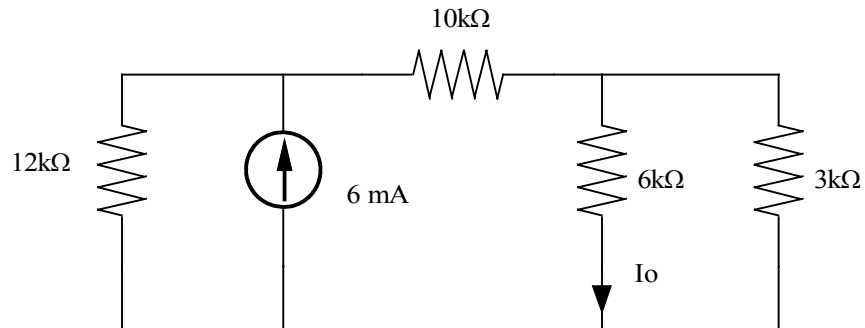

Suggested Solution

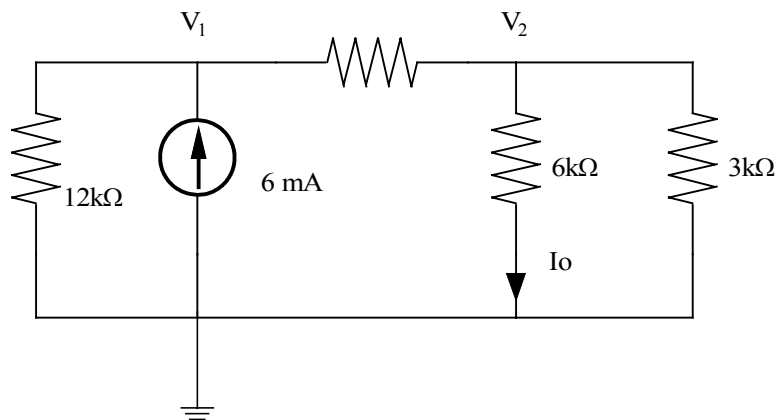

$$\frac{V_1}{12k} + \frac{V_1 - V_2}{10k} = \frac{6}{k}$$

$$\frac{V_2 - V_1}{10k} + \frac{V_2}{6k} + \frac{V_2}{3k} = 0$$

$$\begin{bmatrix} V_1 \\ V_2 \end{bmatrix} = \begin{bmatrix} \frac{1}{12k} + \frac{1}{10k} & \frac{-1}{10k} \\ \frac{-1}{10k} & \frac{1}{10k} + \frac{1}{6k} + \frac{1}{3k} \end{bmatrix}^{-1} \begin{bmatrix} \frac{6}{k} \\ 0 \end{bmatrix} = \begin{bmatrix} 36 \\ 6 \end{bmatrix} \therefore I_0 = \frac{6}{6} = 1mA$$

$1mA$

Problem 3.2

Find I_0 in the circuit using nodal analysis.

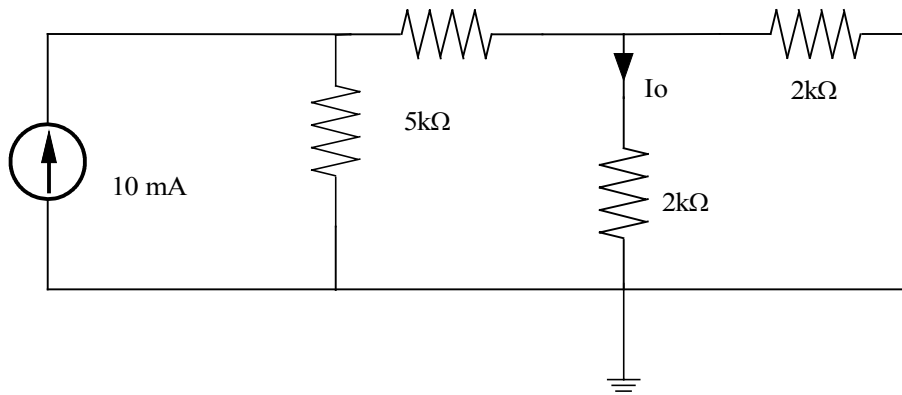

Suggested Solution

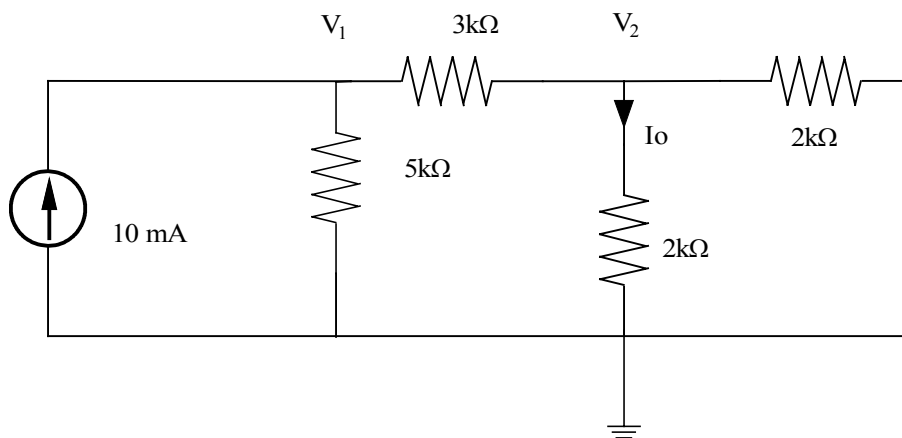

$$\frac{V_1}{5k} + \frac{V_1 - V_2}{3k} = \frac{10}{k}$$

$$\frac{V_2 - V_1}{3k} + \frac{V_2}{2k} + \frac{V_2}{2k} = 0$$

$$\begin{bmatrix} V_1 \\ V_2 \end{bmatrix} = \begin{bmatrix} \frac{1}{5k} + \frac{1}{3k} & \frac{-1}{3k} \\ \frac{-1}{3k} & \frac{1}{3k} + \frac{1}{2k} + \frac{1}{2k} \end{bmatrix}^{-1} \begin{bmatrix} \frac{10}{k} \\ 0 \end{bmatrix} = \begin{bmatrix} 22.2 \\ 5.56 \end{bmatrix} \therefore I_0 = \frac{5.56}{2k} = 2.78mA$$

2.78mA

Problem 3.3

Find V_2 in the circuit shown using nodal analysis.

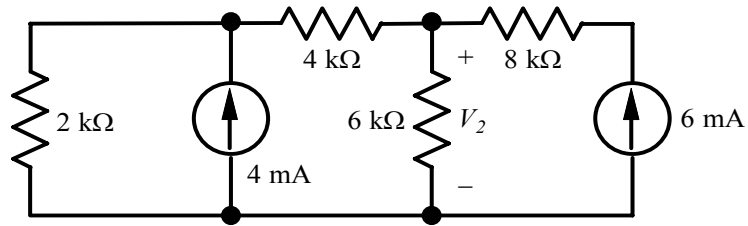

Suggested Solution

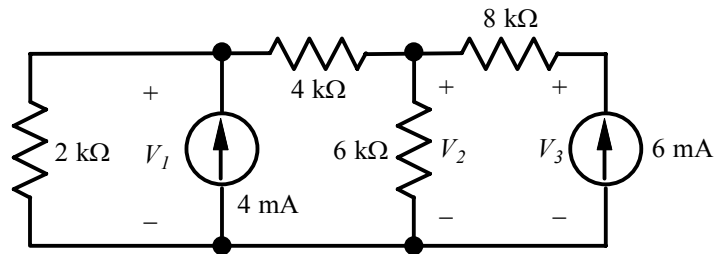

$$\frac{V_1}{2 \text{ k}\Omega} + \frac{V_1 - V_2}{4 \text{ k}\Omega} = 4 \text{ mA}$$

$$\frac{V_2 - V_1}{4 \text{ k}\Omega} + \frac{V_2}{6 \text{ k}\Omega} + \frac{V_2 - V_3}{8 \text{ k}\Omega} = 0$$

$$\frac{V_3 - V_2}{8 \text{ k}\Omega} = 6 \text{ mA}$$

In matrix form:

$$\begin{bmatrix} \frac{1}{2000} + \frac{1}{4000} & -\frac{1}{4000} & 0 \\ -\frac{1}{4000} & \frac{1}{4000} + \frac{1}{6000} + \frac{1}{8000} & -\frac{1}{8000} \\ 0 & -\frac{1}{8000} & \frac{1}{8000} \end{bmatrix} \begin{bmatrix} V_1 \\ V_2 \\ V_3 \end{bmatrix} = \begin{bmatrix} 0.004 \\ 0 \\ 0.006 \end{bmatrix} \Rightarrow V_2 = 22 \text{ V}$$

Alternately, since we know the current through the $8 \text{ k}\Omega$ resistor is 6 mA , we know that $V_3 = V_2 + 48 \text{ V}$. Therefore, we really need only 2 equations to solve this problem. Those are:

$$\frac{V_1}{2 \text{ k}\Omega} + \frac{V_1 - V_2}{4 \text{ k}\Omega} = 4 \text{ mA}$$

Problem 3.4

Use nodal analysis to find V_o in the circuit shown.

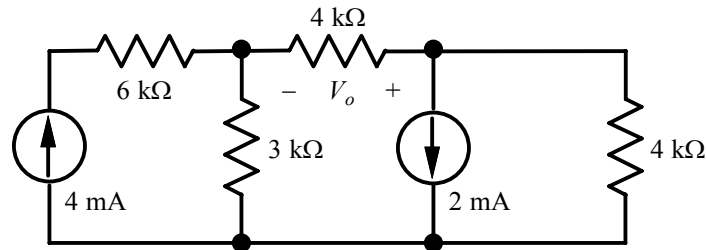

Suggested Solution

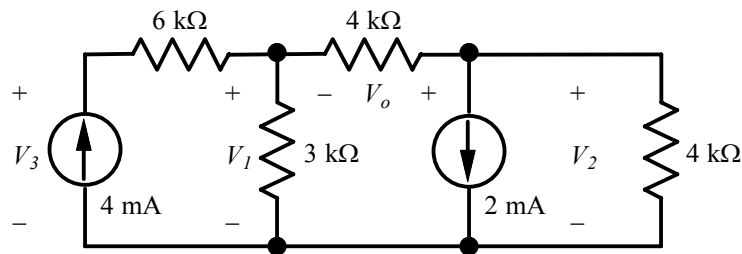

$$\frac{V_3 - V_1}{6 \text{ k}\Omega} = 4 \text{ mA}$$

$$\frac{V_1 - V_3}{6 \text{ k}\Omega} + \frac{V_1}{3 \text{ k}\Omega} + \frac{V_1 - V_2}{4 \text{ k}\Omega} = 0$$

$$\frac{V_2 - V_1}{4 \text{ k}\Omega} + \frac{V_2}{4 \text{ k}\Omega} = -2 \text{ mA}$$

In matrix form:

$$\begin{bmatrix} -\frac{1}{6000} & 0 & \frac{1}{6000} \\ \frac{1}{6000} + \frac{1}{3000} + \frac{1}{4000} & -\frac{1}{4000} & -\frac{1}{6000} \\ -\frac{1}{4000} & \frac{1}{4000} + \frac{1}{4000} & 0 \end{bmatrix} \begin{bmatrix} V_1 \\ V_2 \\ V_3 \end{bmatrix} = \begin{bmatrix} 0.004 \\ 0 \\ -0.002 \end{bmatrix} \Rightarrow \begin{bmatrix} V_1 \\ V_2 \\ V_3 \end{bmatrix} = \begin{bmatrix} 6.5455 \\ -0.7273 \\ 30.5455 \end{bmatrix}$$

$$\therefore V_o = V_2 - V_1 = -0.73 - 6.55 = -7.28 \text{ V}$$

Alternately, since we know the current through the $6 \text{ k}\Omega$ resistor is 4 mA , we know that $V_3 = V_1 + 24 \text{ V}$. Therefore, we really need only 2 equations to solve this problem. Those are:

Problem 3.5

Find I_0 in the circuit using nodal analysis

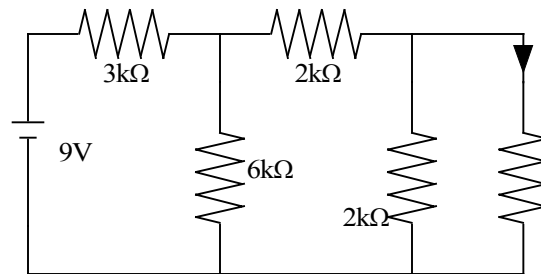

Suggested Solution

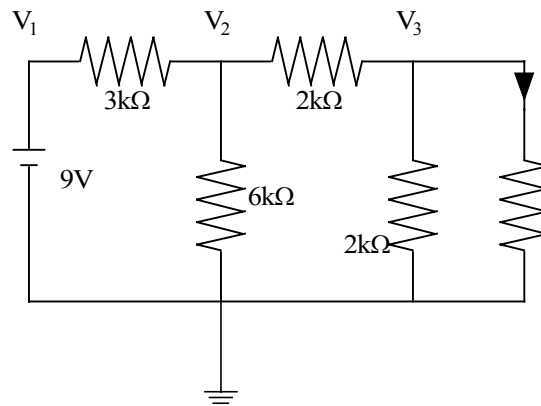

$$V_1 = 9V$$

$$\frac{9 - V_2}{3k} = \frac{V_2}{6k} + \frac{V_2 - V_3}{2k}$$

$$\frac{V_3 - V_2}{2k} + \frac{V_3}{2k} + \frac{V_3}{2k} = 0 \Rightarrow V_3 = 1.2V, I_0 = \frac{1.2}{2k} = 0.6mA$$

$$V_3 = 1.2V$$

$$I_0 = 0.6mA$$

Problem 3.6

Use nodal analysis to find both V_1 and V_o in the circuit shown.

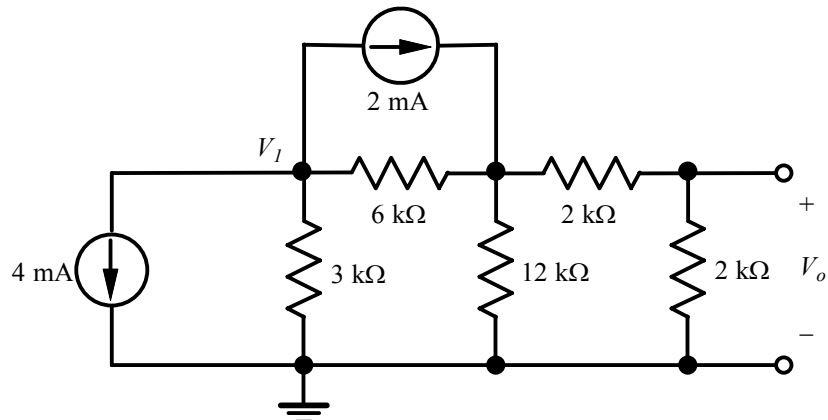

Suggested Solution

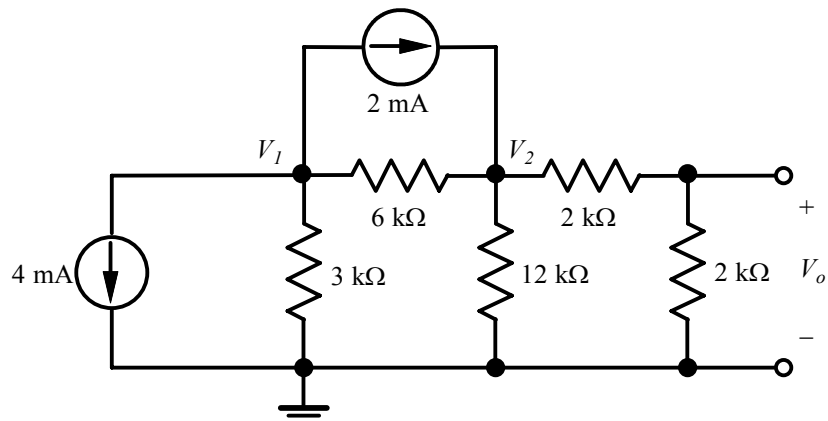

$$\frac{V_1}{3 \text{ k}\Omega} + \frac{V_1 - V_2}{6 \text{ k}\Omega} = -4 \text{ mA} - 2 \text{ mA}$$

$$\frac{V_2 - V_1}{6 \text{ k}\Omega} + \frac{V_2}{12 \text{ k}\Omega} + \frac{V_2}{2 \text{ k}\Omega + 2 \text{ k}\Omega} = 2 \text{ mA}$$

In matrix form:

$$\begin{bmatrix} \frac{1}{3000} + \frac{1}{6000} & -\frac{1}{6000} \\ -\frac{1}{6000} & \frac{1}{6000} + \frac{1}{12000} + \frac{1}{4000} \end{bmatrix} \begin{bmatrix} V_1 \\ V_2 \end{bmatrix} = \begin{bmatrix} -0.006 \\ 0.002 \end{bmatrix} \Rightarrow \begin{bmatrix} V_1 \\ V_2 \end{bmatrix} = \begin{bmatrix} -12 \\ 0 \end{bmatrix}$$

$$\therefore V_1 = -12 \text{ V} \text{ and } V_o = \frac{2000}{2000 + 2000} V_2 = 0 \text{ V}$$

Problem 3.7

Find V_1 and V_2 in the circuit using nodal analysis Then solve the problem using Matlab and compare your answers

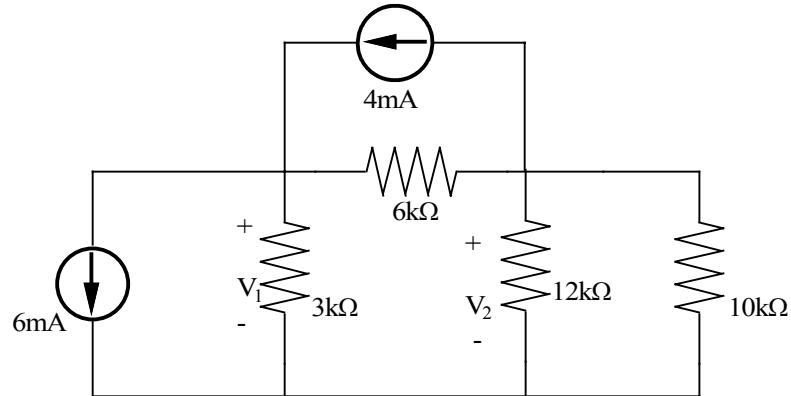

Suggested Solution

$$\frac{V_1}{6k} + \frac{V_1 - V_2}{4k} = \frac{4}{k} - \frac{6}{k}$$

$$\frac{V_2 - V_1}{4k} + \frac{V_2}{5k} + \frac{V_2}{10k} = \frac{-4}{k}$$

$$\Rightarrow \begin{bmatrix} V_1 \\ V_2 \end{bmatrix} = \begin{bmatrix} \frac{1}{6k} + \frac{1}{4k} & \frac{-1}{4k} \\ \frac{-1}{4k} & \frac{1}{4k} + \frac{1}{5k} + \frac{1}{10k} \end{bmatrix}^{-1} \begin{bmatrix} \frac{-2}{k} \\ \frac{-4}{k} \end{bmatrix}$$

$$V_1 = -12.6V; V_2 = -13V$$

Nodal – Equations

$$6m + V_1/6k + (V_1 - V_2)/4k - 4m = 0$$

$$4m + (V_2 - V_1)/4k + V_2/5k + V_2/10k = 0$$

or

$$-24 = 5V_1 - 3V_2$$

$$-80 = -5V_1 + 11V_2$$

In Matlab

```
>> g=[5 -3;-5 11]
```

g =

```
    5   -3  
   -5   11
```

```
>> i=[-24;-80]
```

i =

```
   -24  
   -80
```

```
>> v=inv(g)*i
```

v =

```
 -12.6000  
 -13.0000
```

$V_1 = -12.6V; V_2 = -13V$

$V_1 = -12.6V; V_2 = -13V$

Problem 3.8

Find I_0 in the network using nodal analysis

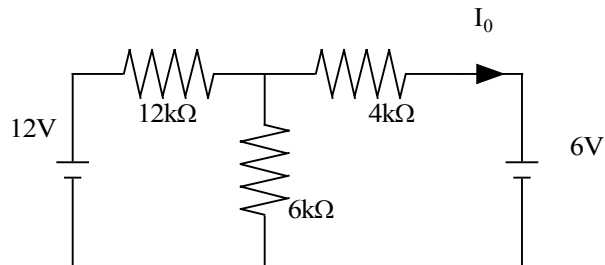

Suggested Solution

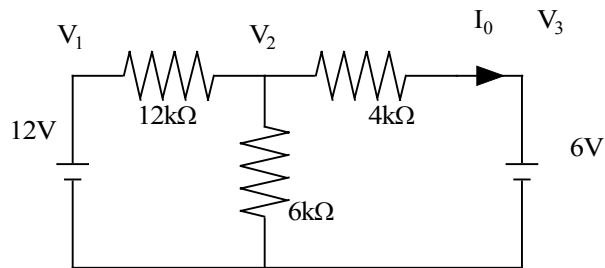

$$V_1 = 12V; V_3 = -6V$$

$$\frac{V_2 - 12}{12K} + \frac{V_2}{6k} + \frac{V_2 + 6}{4k} = 0 \Rightarrow V_2 = -1V$$

$$V_2 = -1V; I_0 = 1.25mA$$

$$I_0 = \frac{V_2 - V_3}{4k} = \frac{-1 + 6}{4k} = 1.25mA$$

Problem 3.9

Find V_0 in the network using nodal analysis

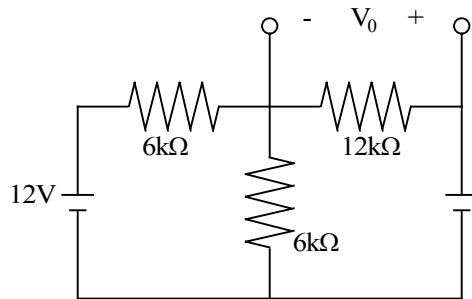

Suggested Solution

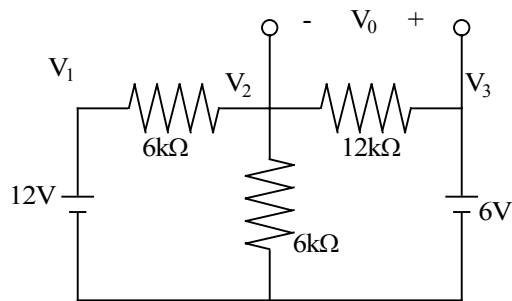

$$V_1 = 12V; V_3 = 6V$$

$$\frac{V_2 - 12}{6K} + \frac{V_2}{6k} + \frac{V_2 - 6}{12k} = 0 \Rightarrow V_2 = -6V$$

$$V_2 = 6v \therefore V_0 = V_2 - V_3 = 0V$$

$$\Rightarrow V_2 = 6v \therefore V_0 = V_2 - V_3 = 0V$$

Problem 3.10

Use nodal analysis to find I_o and I_1 in the circuit shown.

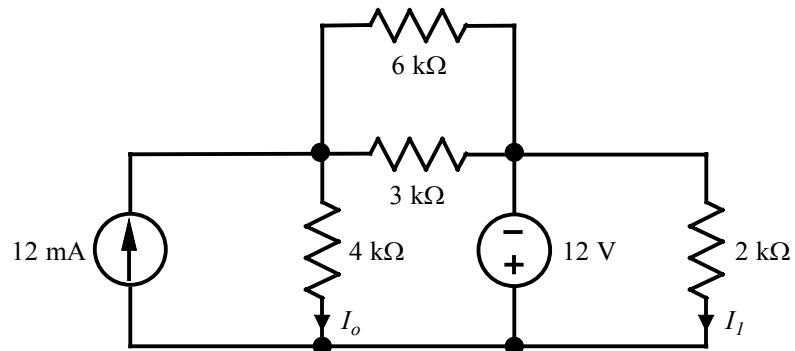

Suggested Solution

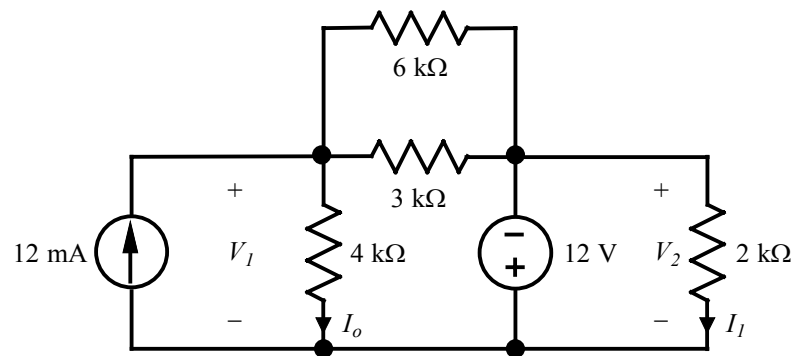

$$V_2 = -12 \text{ V} \Rightarrow I_1 = \frac{V_2}{2 \text{ k}\Omega} = \frac{-12}{2000} = -6 \text{ mA}$$

$$-12 \text{ mA} + \frac{V_1}{4 \text{ k}\Omega} + \frac{V_1 - (-12 \text{ V})}{6 \text{ k}\Omega} + \frac{V_1 - (-12 \text{ V})}{3 \text{ k}\Omega} = 0 \Rightarrow V_1 = 8 \text{ V} \Rightarrow I_o = \frac{V_1}{4 \text{ k}\Omega} = \frac{8}{4000} = 2 \text{ mA}$$

$$I_o = 2 \text{ mA}, I_1 = -6 \text{ mA}$$

Problem 3.11

Find I_0 in the circuit using nodal analysis

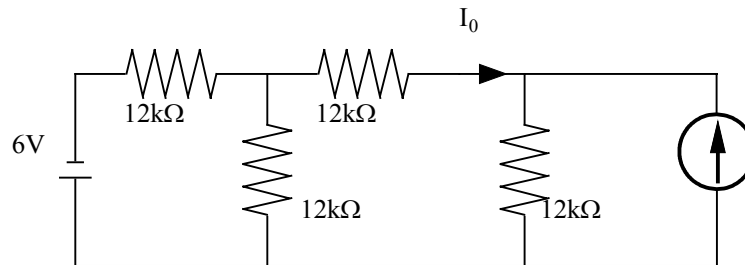

Suggested Solution

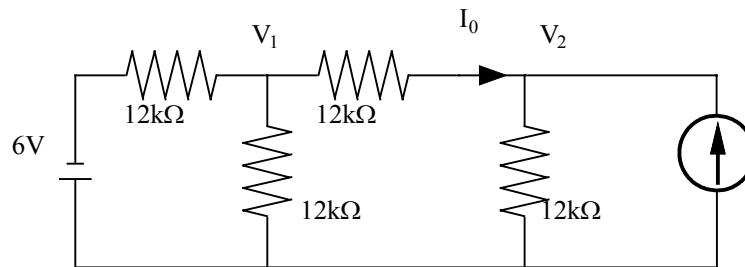

$$\frac{V_1 + 6}{12k} + \frac{V_1}{12k} + \frac{V_1 - V_2}{12k} = 0$$

$$\frac{V_2 - V_1}{12k} + \frac{V_2}{12k} = \frac{2}{K}$$

\Rightarrow

$$\frac{3V_1}{12k} - \frac{V_2}{12k} = \frac{-1}{12k}$$

$$\frac{-V_1}{12k} + \frac{2V_2}{12k} = \frac{2}{12k}$$

$$3V_1 - V_2 = -6$$

$$-V_1 + 2V_2 = 24$$

\Rightarrow

$$\begin{bmatrix} V_1 \\ V_2 \end{bmatrix} = \begin{bmatrix} 3 & -1 \\ -1 & 2 \end{bmatrix} \begin{bmatrix} -6 \\ 24 \end{bmatrix} = \begin{bmatrix} \frac{12}{5} \\ \frac{66}{5} \end{bmatrix}$$

$$I_0 = \frac{\frac{12}{5} - \frac{66}{5}}{12k} = -0.9mA$$

$$I_0 = -0.9mA$$

Problem 3.12

Use nodal analysis to find V_0 in the network

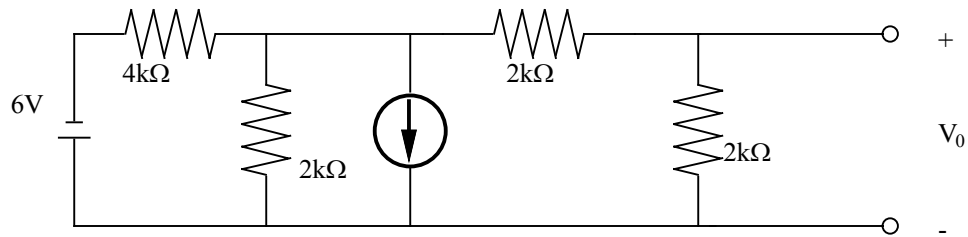

Suggested Solution

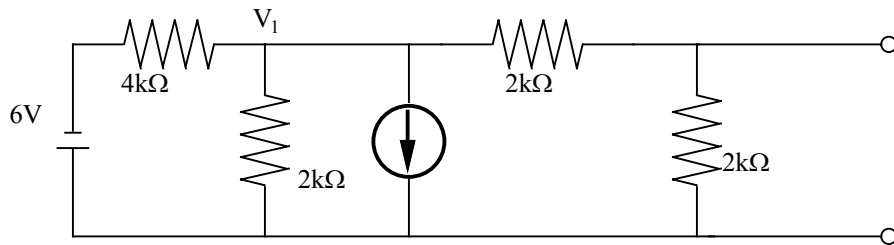

$$\frac{V_1 - (-6)}{4k} + \frac{V_1}{2k} + \frac{2}{k} + \frac{V_1}{2k + 2k} = 0$$

\Rightarrow

$$V_1 = \frac{-7}{2}V; \therefore V_0 = \frac{-7}{2} \left(\frac{2k}{2k + 2k} \right)$$

$$V_0 = \frac{-7}{4}V$$

$$V_1 = \frac{-7}{2}V$$

$$V_0 = \frac{-7}{4}V$$

Problem 3.13

Find I_0 in the network

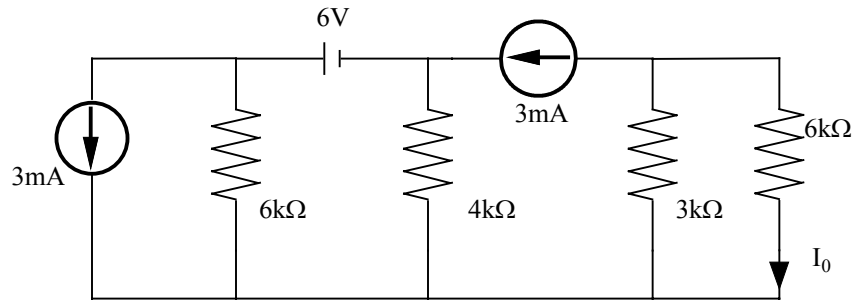

Suggested Solution

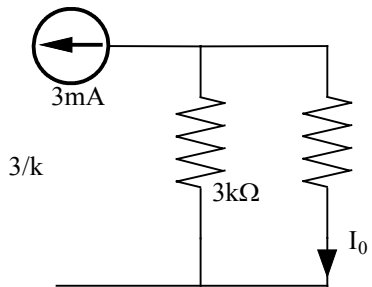

$$I_0 = \frac{-3}{k} \left(\frac{3k}{3k + 6k} \right) = -1mA$$

$$I_0 = -1mA$$

Problem 3.14

Find V_0 in the network

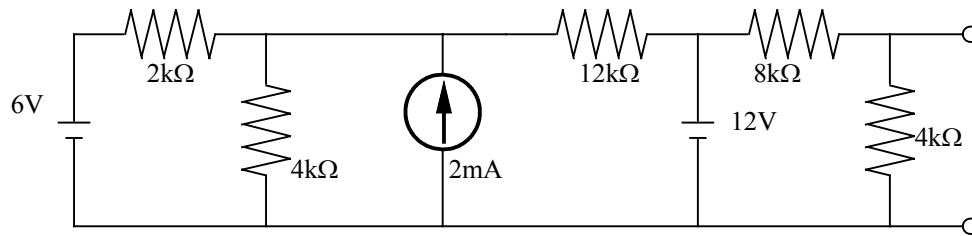

Suggested Solution

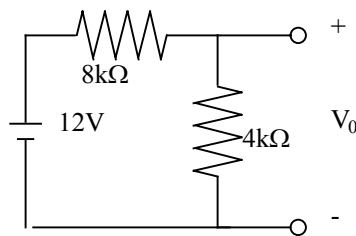

$$V_0 = 12 \left(\frac{4k}{4k + 8k} \right) = 4V$$

$$V_0 = 4V$$

Problem 3.15

Use nodal analysis to find V_0 .

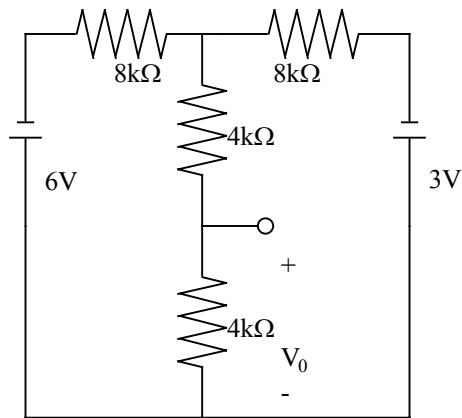

Suggested Solution

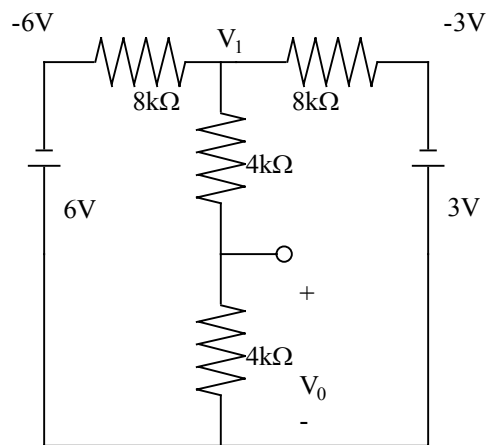

$$\frac{V_1 + 6}{6k} + \frac{V_1}{2k + 2k} + \frac{V_1 + 3}{2k} = 0 \Rightarrow V_1 = \frac{-5}{2}V$$

$$V_0 = \frac{-5}{2} \left(\frac{1k}{1k + 2k} \right) = \frac{-5}{6}V$$

$$V_0 = \frac{-5}{6}V$$

Problem 3.16

Write the node equations for the circuit in matrix form and find the node voltages using Matlab

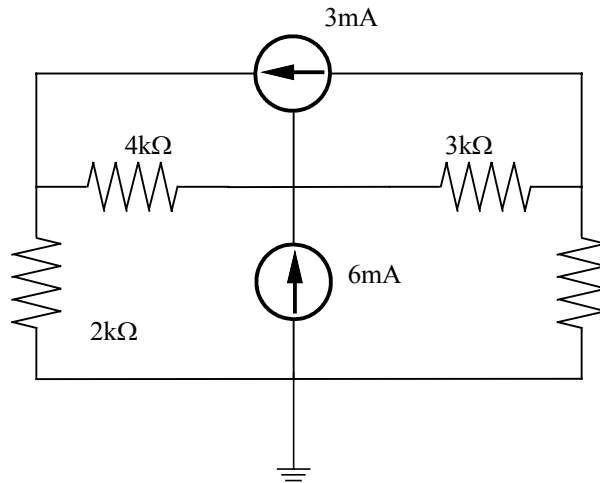

Suggested Solution

$$\frac{V_1}{2k} + \frac{V_1 - V_2}{2k + 2k} = \frac{3}{k}$$

$$\frac{V_2 - V_1}{1k} + \frac{V_2 - V_3}{3k} = \frac{6}{k}$$

$$\frac{V_3 - V_2}{3k} + \frac{V_3}{4k} = \frac{-3}{k}$$

⇒

$$V_1 \left(\frac{3}{2k} \right) - V_2 \left(\frac{1}{k} \right) = \frac{3}{k}$$

$$-V_1 \left(\frac{1}{k} \right) + V_2 \left(\frac{4}{3k} \right) - V_3 \left(\frac{1}{3k} \right) = \frac{6}{k}$$

$$0 - V_2 \left(\frac{1}{3k} \right) + V_3 \left(\frac{7}{12k} \right) = \frac{-3}{k}$$

$$\begin{bmatrix} V_1 \\ V_2 \\ V_3 \end{bmatrix} = \begin{bmatrix} \frac{3}{2k} & \frac{-1}{k} & 0 \\ \frac{-1}{k} & \frac{4}{3k} & \frac{-1}{3k} \\ 0 & \frac{-1}{3k} & \frac{7}{12k} \end{bmatrix} \begin{bmatrix} \frac{3}{k} \\ \frac{6}{k} \\ \frac{-3}{k} \end{bmatrix}$$

Nodal - Equations

$$V_1 / 2k + (V_1 - V_2) / k - 3m = 0$$

$$(V_3 - V_2) / 3k + V_3 / 4k + 3m = 0$$

$$V_1 / 2k + V_3 / 4k - 6m = 0$$

or

$$6 = 3V_1 - 2V_2$$

$$-36 = -4V_1 + 7V_2$$

$$24 = 2V_1 + V_3$$

Using Matlab

```
EDU» g=[3 -2 0;0 -4 7;2 0 1]
```

g =

```
 3  -2  0
 0  -4  7
 2   0  1
```

```
EDU» i=[6;-36;24]
```

i =

```
 6
-36
 24
```

```
EDU» v=inv(g)*i
```

v =

```
10.8000
13.2000
 2.4000
```

Problem 3.17

Find I_1 in the network shown.

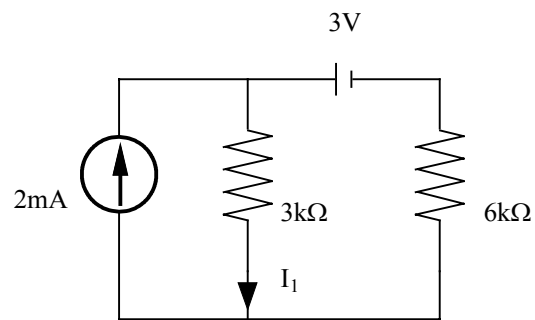

Suggested Solution

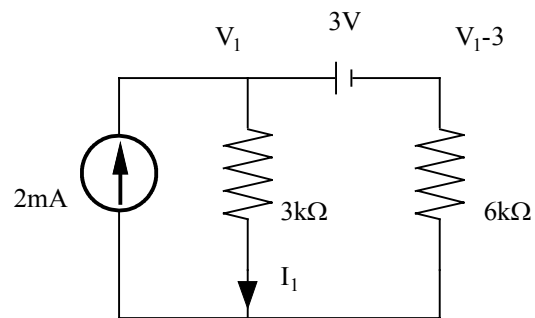

$$\frac{V_1}{3k} + \frac{V_1 - 3}{6k} = \frac{2}{k} \Rightarrow V_1 = 5V; I_1 = 1.67mA$$

$$I_1 = 1.67mA$$

Problem 3.18

Find I_0 in the network shown.

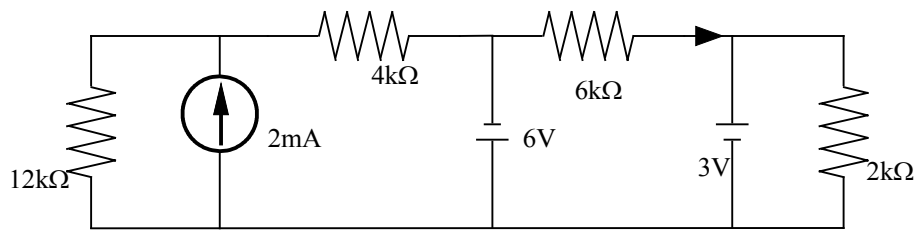

Suggested Solution

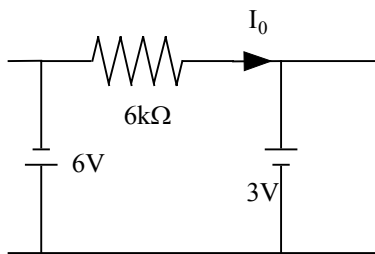

$$I_0 = \frac{-6-3}{6k} = -1.5mA$$

$$I_0 = -1.5mA$$

Problem 3.19

Find I_0 in the circuit shown.

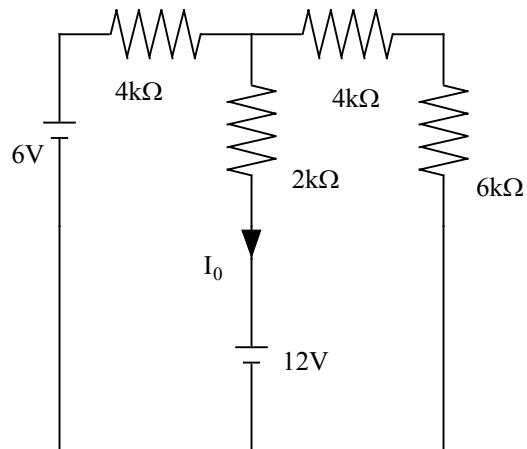

Suggested Solution

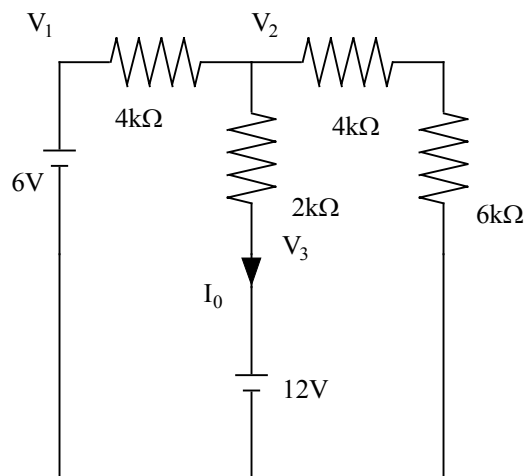

$$V_1 = 6V, V_3 = 12V$$

$$\frac{V_2 - V_1}{3k} + \frac{V_2 - V_3}{2k} + \frac{V_2}{10k} = 0$$

\Rightarrow

$$V_2 = \frac{150}{17}V, V_3 = 12 = \frac{204}{17}V$$

$$I_0 = \left(\frac{150}{17} - \frac{204}{17} \right) / 2k = \frac{-27}{17} mA = -1.59mA$$

$$I_0 = -1.59mA$$

Problem 3.20

Find I_0 in the network using nodal analysis

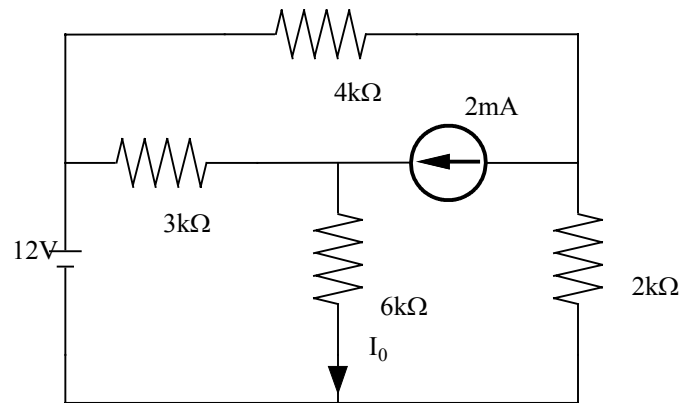

Suggested Solution

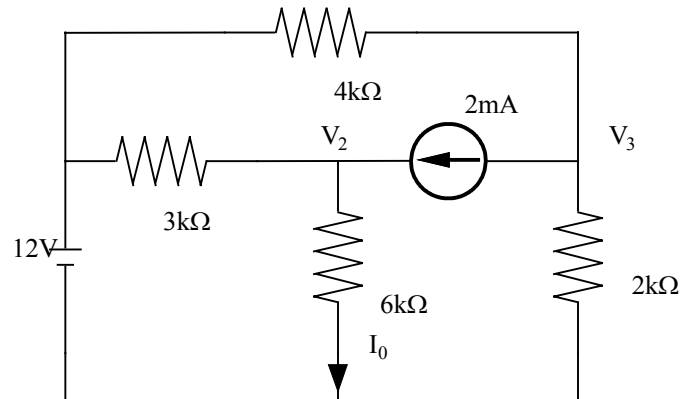

$$\frac{V_2 - 12}{3k} + \frac{V_2}{6k} = \frac{2}{k} \therefore V_2 = 12V \text{ and } I_0 = 2mA$$

$$I_0 = 2mA$$

Problem 3.21

Use nodal analysis to find V_0 in the network shown. Then solve this problem using Matlab and compare your results.

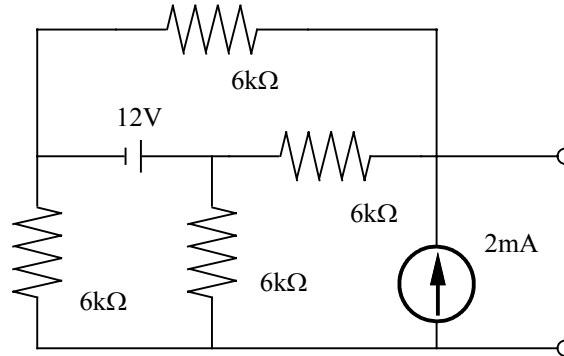

Suggested Solution

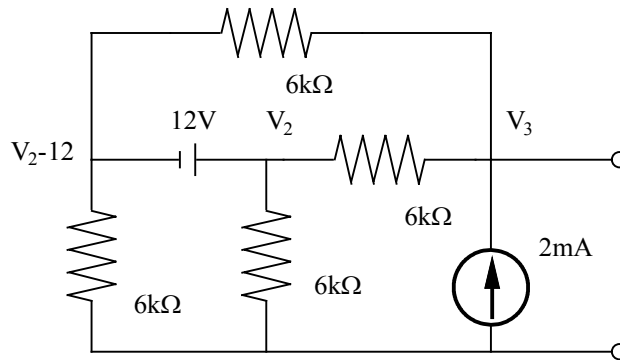

$$\frac{V_2 - 12}{1k} + \frac{V_2 - 12 - V_3}{1k} + \frac{V_2}{1k} + \frac{V_2 - V_3}{1k} = 0$$

$$\frac{V_3 - V_2}{1k} + \frac{V_3 - (V_2 - 12)}{1k} = \frac{2}{k}$$

$$\frac{4}{k}V_2 - \frac{2}{k}V_3 = \frac{24}{k}; \quad \frac{-2V_2}{k} + \frac{2V_3}{k} = \frac{-10}{k}$$

\Rightarrow

$$4V_2 - 2V_3 = 24; \quad -2V_2 + 2V_3 = -10$$

\Rightarrow

$$2V_2 = 14 \Rightarrow V_2 = 7V \text{ and } V_3 = 2V$$

Nodal - Equations

$$V_2 - V_1 = 12$$

$$V_1/1k + V_2/1K = 2m$$

$$(V_0 - V_2)/1k + (V_0 - V_1)/1k = 2m$$

or

$$12 = -V_1 + V_2$$

$$2 = V_1 + V_2$$

$$2 = -V_1 - V_2 + 2V_0$$

EDU» g=[-1 1 0;1 1 0;-1 -1 2]

g =

```
-1  1  0
 1  1  0
-1 -1  2
```

EDU» i=[12;2;2]

i =

```
12
 2
 2
```

EDU» v=inv(g)*i

v =

```
-5
 7
 2
```

$$V_0 = 2V$$

Problem 3.22

Find V_0 in the circuit shown using Nodal Analysis

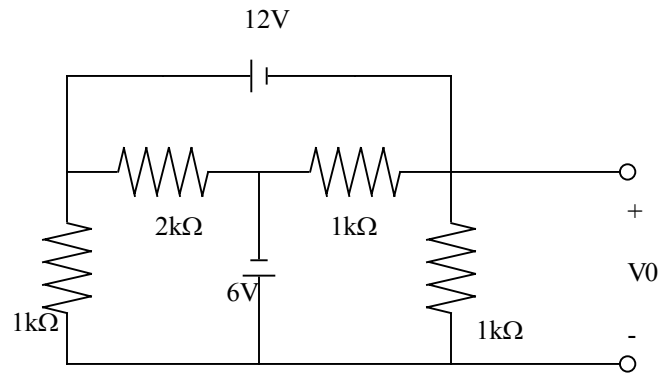

Suggested Solution

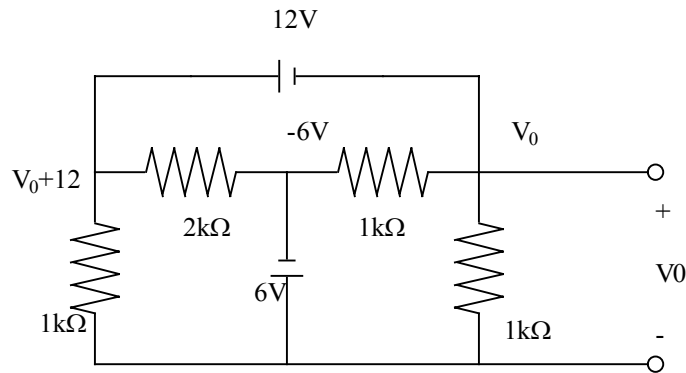

$$\frac{V_0 + 12}{1k} + \frac{V_0 + 12 + 6}{2k} + \frac{V_0 + 6}{1k} + \frac{V_0}{1k} = 0$$

$$V_0 \left(\frac{7}{2k} \right) = \frac{-27}{1k}$$

$$\therefore V_0 = -7.17V$$

$$V_0 = -7.17V$$

Problem 3.23

Use nodal analysis to find I_0 in the network shown.

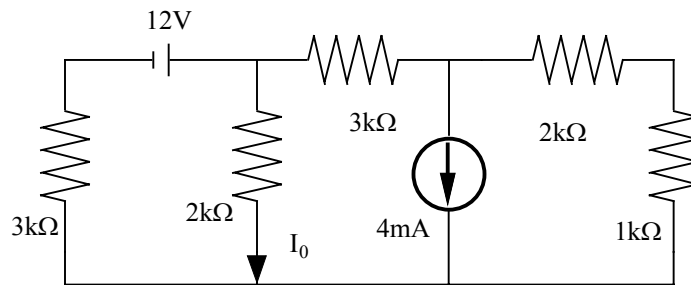

Suggested Solution

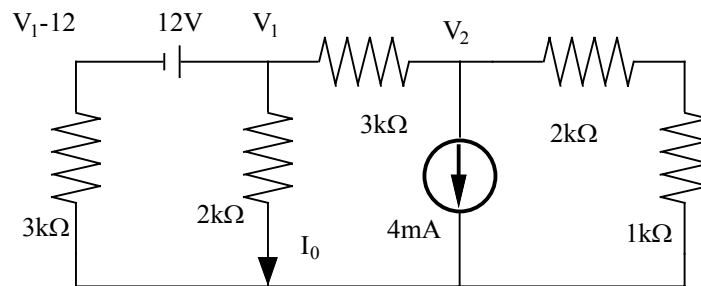

$$\frac{V_1 - 12}{3k} + \frac{V_1}{2k} + \frac{V_1 - V_2}{3k} = 0$$

$$\frac{V_2 - V_1}{3k} + \frac{4}{k} + \frac{V_2}{3k} = 0$$

\Rightarrow

$$\frac{7V_1}{6k} - \frac{V_2}{3k} = \frac{4}{k}$$

$$\frac{-1V_1}{3k} + \frac{2V_2}{3k} = \frac{-4}{k}$$

$$\begin{bmatrix} V_1 \\ V_2 \end{bmatrix} = \begin{bmatrix} 7 & -1 \\ 6k & 3k \\ -1 & 2 \\ 3k & 3k \end{bmatrix}^{-1} \begin{bmatrix} 4 \\ k \\ -4 \\ k \end{bmatrix} \Rightarrow V_1 = 2V \text{ and } I_0 = \frac{2}{2k} = 1mA$$

$$I_0 = 1mA$$

Problem 3.24

Find I_o in the network shown.

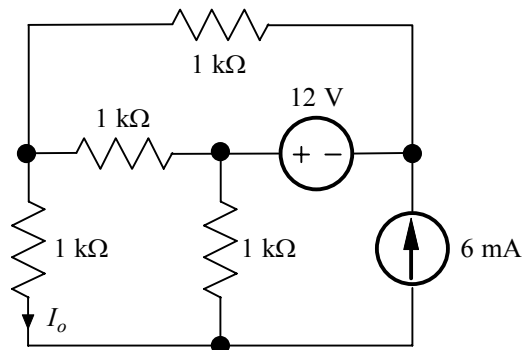

Suggested Solution

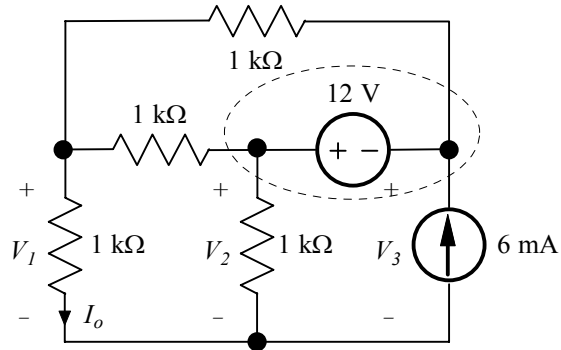

$$V_2 = V_3 + 12 \text{ V} \quad \Rightarrow \quad V_2 - V_3 = 12$$

$$\frac{V_1}{1 \text{ k}\Omega} + \frac{V_1 - V_2}{1 \text{ k}\Omega} + \frac{V_1 - V_3}{1 \text{ k}\Omega} = 0 \quad \Rightarrow \quad 3V_1 - V_2 - V_3 = 0$$

$$\frac{V_2 - V_1}{1 \text{ k}\Omega} + \frac{V_2}{1 \text{ k}\Omega} + \frac{V_3 - V_1}{1 \text{ k}\Omega} - 6 \text{ mA} = 0 \quad \Rightarrow \quad -2V_1 + 2V_2 + V_3 = 6$$

In matrix form:

$$\begin{bmatrix} 0 & 1 & -1 \\ 3 & -1 & -1 \\ -2 & 2 & 1 \end{bmatrix} \begin{bmatrix} V_1 \\ V_2 \\ V_3 \end{bmatrix} = \begin{bmatrix} 12 \\ 0 \\ 6 \end{bmatrix} \quad \Rightarrow \quad V_1 = 0 \text{ V}$$

$$\therefore I_o = \frac{V_1}{1 \text{ k}\Omega} = 0 \text{ A}$$

Problem 3.25

Use nodal analysis to find V_0 in the circuit shown.

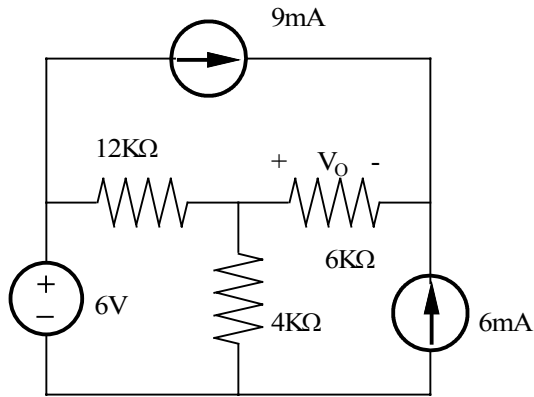

Suggested Solution

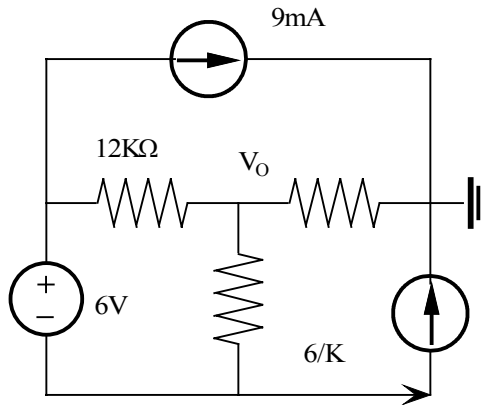

Note the position of the reference node

KCL

$$\frac{9}{K} + \frac{6}{K} + \frac{V_0}{6K} = 0$$

$$V_0 = -90V$$

$$V_0 = -90V$$

Problem 3.26

Find the V_o in the circuit shown using nodal analysis.

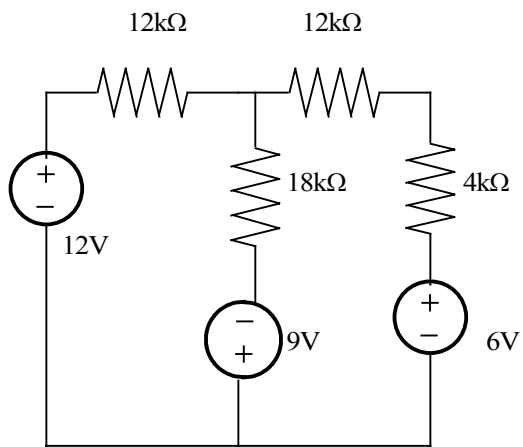

Suggested Solution

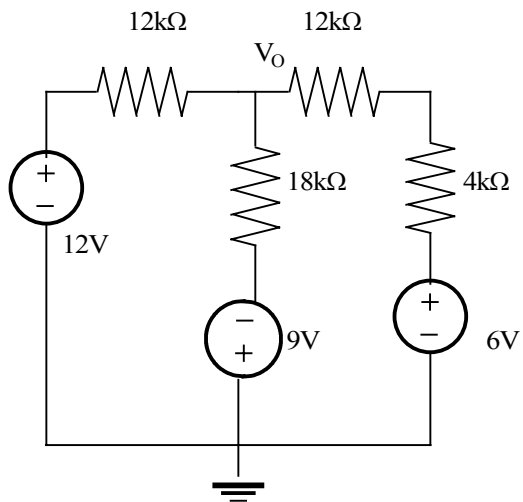

$$\frac{V_o - 12}{12K} + \frac{V_o + 9}{18K} + \frac{V_o + 6}{16K} = 0$$

$$V_o \left(\frac{1}{12} + \frac{1}{18} + \frac{1}{16} \right) = 0.621V$$

$$V_o = 0.621V$$

Problem 3.27

Find V_o in the network shown using nodal analysis.

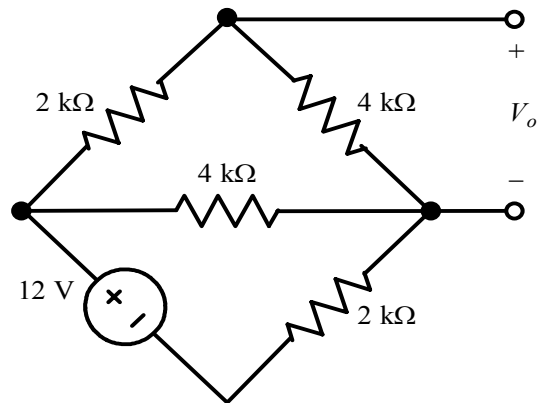

Suggested Solution

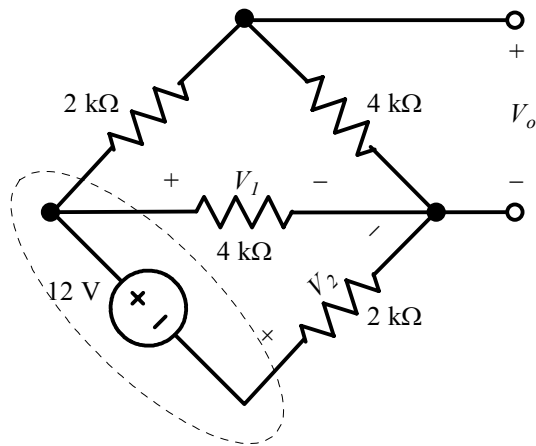

$$V_1 - V_2 = 12 \text{ V}$$

$$\frac{V_o - V_1}{2 \text{ k}\Omega} + \frac{V_o}{4 \text{ k}\Omega} = 0 \quad \Rightarrow \quad 3V_o - 2V_1 = 0$$

$$\frac{V_1 - V_o}{2 \text{ k}\Omega} + \frac{V_1}{4 \text{ k}\Omega} + \frac{V_2}{2 \text{ k}\Omega} = 0 \quad \Rightarrow \quad -2V_o + 3V_1 + 2V_2 = 0$$

In matrix form:

$$\begin{bmatrix} 0 & 1 & -1 \\ 3 & -2 & 0 \\ -2 & 3 & 2 \end{bmatrix} \begin{bmatrix} V_o \\ V_1 \\ V_2 \end{bmatrix} = \begin{bmatrix} 12 \\ 0 \\ 0 \end{bmatrix} \quad \Rightarrow \quad V_o = 4.36 \text{ V}$$

Problem 3.28

Find V_o in the network shown using nodal analysis.

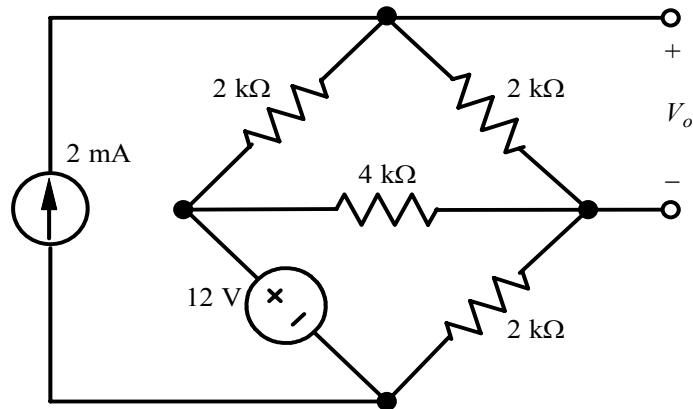

Suggested Solution

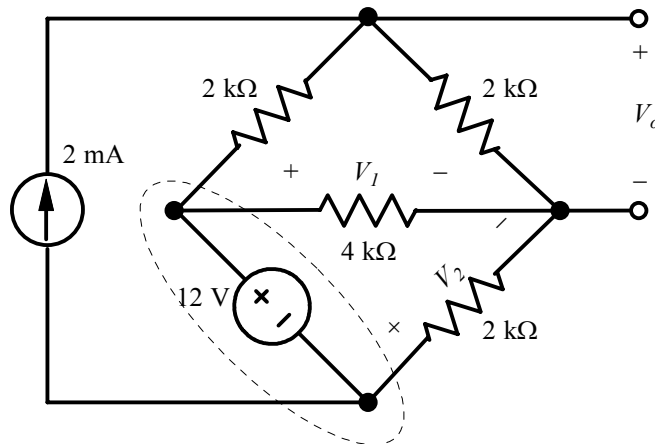

$$V_1 - V_2 = 12 \text{ V}$$

$$\frac{V_o - V_1}{2 \text{ k}\Omega} + \frac{V_o}{2 \text{ k}\Omega} - 2 \text{ mA} = 0 \quad \Rightarrow \quad 2V_o - V_1 = 4$$

$$\frac{V_1 - V_o}{2 \text{ k}\Omega} + \frac{V_1}{4 \text{ k}\Omega} + \frac{V_2}{2 \text{ k}\Omega} + 2 \text{ mA} = 0 \quad \Rightarrow \quad -2V_o + 3V_1 + 2V_2 = -8$$

In matrix form:

$$\begin{bmatrix} 0 & 1 & -1 \\ 2 & -1 & 0 \\ -2 & 3 & 2 \end{bmatrix} \begin{bmatrix} V_o \\ V_1 \\ V_2 \end{bmatrix} = \begin{bmatrix} 12 \\ 4 \\ -8 \end{bmatrix} \quad \Rightarrow \quad V_o = 4.5 \text{ V}$$

Problem 3.29

Suggested Solution

$$\frac{V_1 - 6}{4K} + \frac{2}{K} + \frac{V_1 - V_2}{4K} = 0 \Rightarrow V_1 \left(\frac{1}{4K} + \frac{1}{4K} \right) - V_2 \left(\frac{1}{4K} \right) = \frac{6}{4K} - \frac{2}{K}$$

$$\frac{V_2 - V_1}{4K} - \frac{4}{K} + \frac{V_2}{2K + 2K} = 0 \Rightarrow -V_1 \left(\frac{1}{4K} \right) + V_2 \left(\frac{1}{8K} + \frac{1}{4K} \right) = \frac{4}{K}$$

$$V_2 = 10V$$

$$V_0 = 10 \left(\frac{2K}{2K + 2K} \right) = 5V$$

$$V_0 = 5V$$

$$V_2 = 10V$$

$$V_0 = 5V$$

Problem 3.30

Find I_o in the circuit shown using nodal analysis.

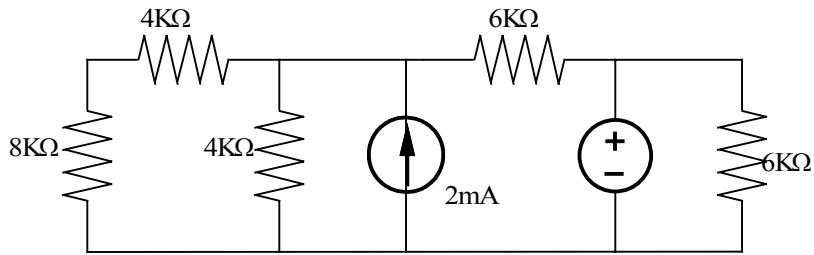

Suggested Solution

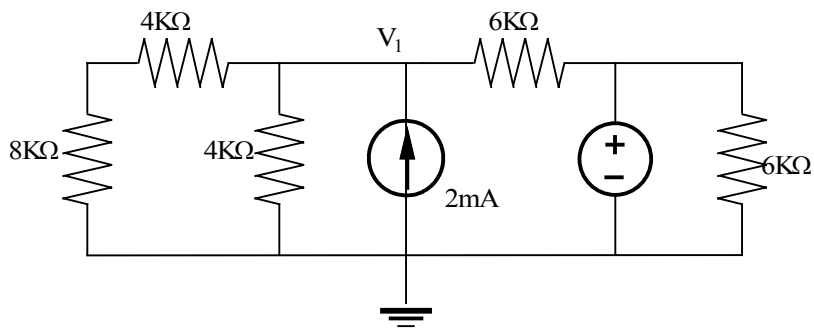

$$\frac{V_1}{4K + 8K} + \frac{V_1}{4K} - \frac{2}{K} + \frac{V_1 - 6}{6K} = 0 \Rightarrow V_1 = 6V$$

$$I_L = \frac{6}{4K} = 1.5mA$$

$$V_1 = 6V$$
$$I_L = 1.5mA$$

Problem 3.31

Find V_o in the circuit shown using nodal analysis.

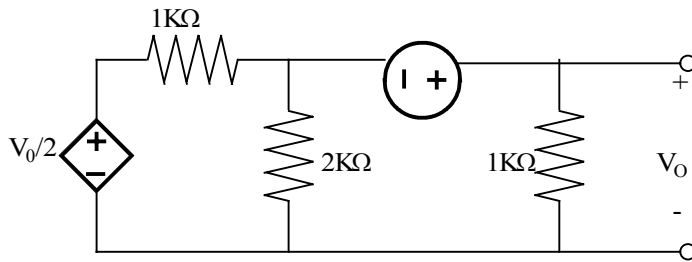

Suggested Solution

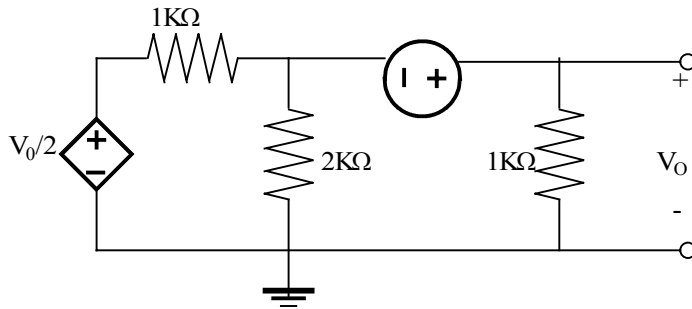

$$\frac{V_o - 12 - \frac{V_o}{2}}{1\text{K}} + \frac{V_o - 12}{2\text{K}} + \frac{V_o}{1\text{K}} = 0$$
$$V_o = 9\text{V}$$

$$V_o = 9\text{V}$$

Problem 3.32

Use nodal analysis to find V_o in the network shown.

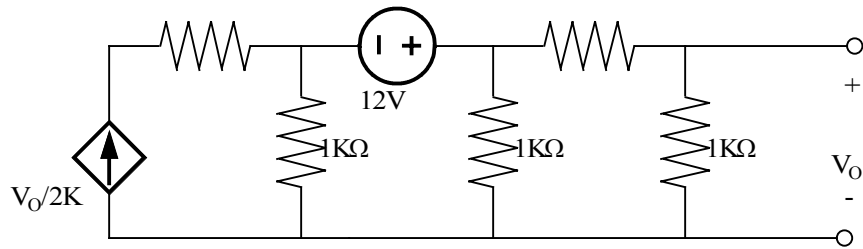

Suggested Solution

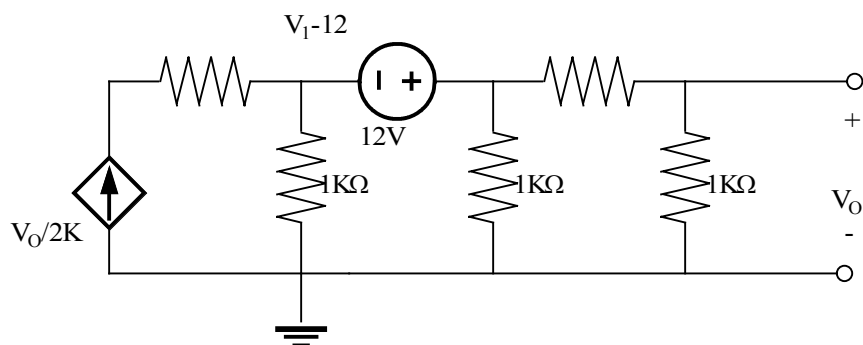

$$\frac{V_1 - 12}{1K} - \frac{V_o}{2K} + \frac{V_1}{1K} + \frac{V_1}{1K + 1K} = 0$$

$$V_o = \frac{1K}{1K + 1K} V_1, V_1 = \frac{V_1}{2}$$

$$V_1 \left(\frac{5}{2K} \right) - \frac{V_o}{2K} = \frac{12}{K}$$

$$2V_o \left(\frac{5}{2K} - \frac{V_o}{2K} \right) = \frac{12}{K}$$

$$V_o = 2.667V$$

$$V_o = 2.667V$$

Problem 3.33

Find the V_o in the circuit shown using nodal analysis. Then solve the problem using matlab and compare your results.

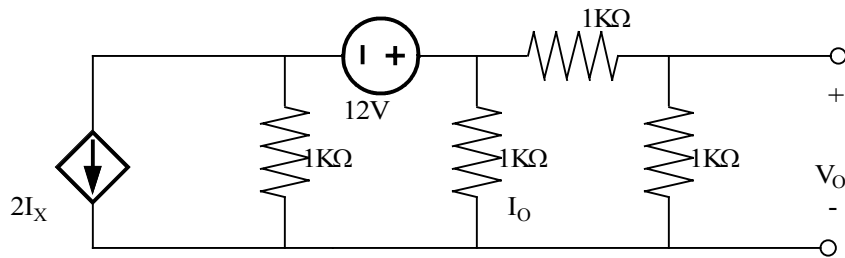

Suggested Solution

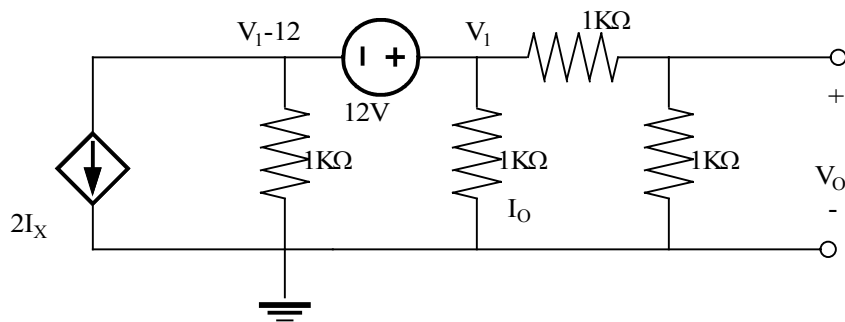

$$2I_x + \frac{V_1 - 12}{1K} + \frac{V_1}{1K} + \frac{V_1}{2K} = 0$$

Where

$$I_x = \frac{V_1}{1K}$$

$$\frac{2V_1}{1K} + \frac{V_1}{1K} - \frac{12}{K} + \frac{V_1}{1K} + \frac{V_1}{2K} = 0 \Rightarrow V_1 = 24/9V$$

$$V_o = 1/2 V_1 = \frac{4}{3}V$$

$$V_o = 1/2 V_1 = \frac{4}{3}V$$

Nodal _ Equations

$$2I_x + V_1/1K + V_2/1K + V_0/1K = 0$$

$$(V_2 - V_0)/1K = V_0/1K$$

$$V_2 - V_1 = 12$$

$$I_x = V_2/1K$$

OR

$$V_1 + 3V_2 + V_0 = 0$$

$$V_2 - 2V_0 = 0$$

$$-V_1 + V_2 = 12$$

EDU» G=[1 3 1;0 1 -2;-1 1 0]

G =

$$\begin{bmatrix} 1 & 3 & 1 \\ 0 & 1 & -2 \\ -1 & 1 & 0 \end{bmatrix}$$

EDU» I=[0;0;12]

I =

$$\begin{bmatrix} 0 \\ 0 \\ 12 \end{bmatrix}$$

EDU» V=inv(G)*I

V =

$$\begin{bmatrix} -9.3333 \\ 2.6667 \\ 1.3333 \end{bmatrix}$$

Problem 3.34

Find I_o in the network shown.

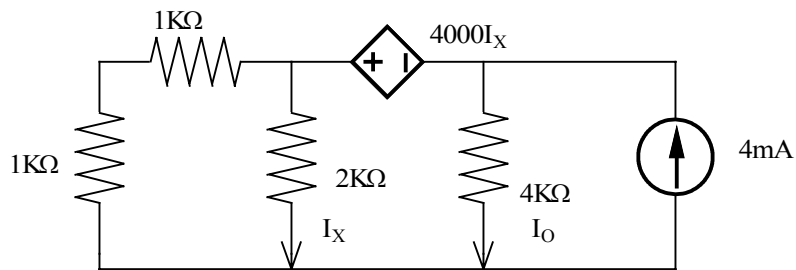

Suggested Solution

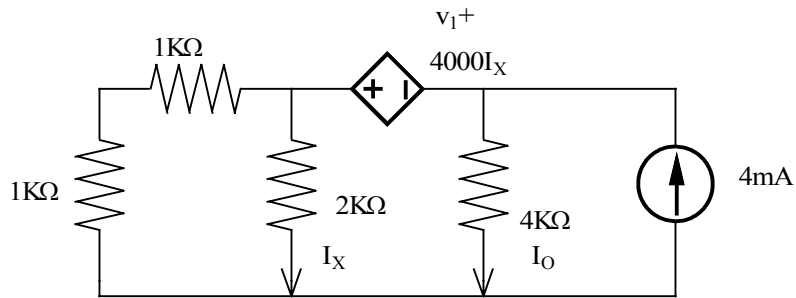

$$\frac{V_1 + 4KI_x}{2K} + \frac{V_1 + 4KI_x}{2K} + \frac{V_1}{4K} = \frac{4}{K}$$

$$\frac{V_1 + 4KI_x}{2K} = I_x \Rightarrow I_x = \frac{-V_1}{2K}$$

$$\frac{5}{4K}V_1 - \frac{4V_1}{2K} = \frac{4}{K}$$

$$V_1 = \frac{-16}{3}V$$

$$I_o = \frac{-4}{3}mA$$

$$V_1 = \frac{-16}{3}V$$

$$I_o = \frac{-4}{3}mA$$

Problem 3.35

Find V_o in the circuit shown using nodal analysis.

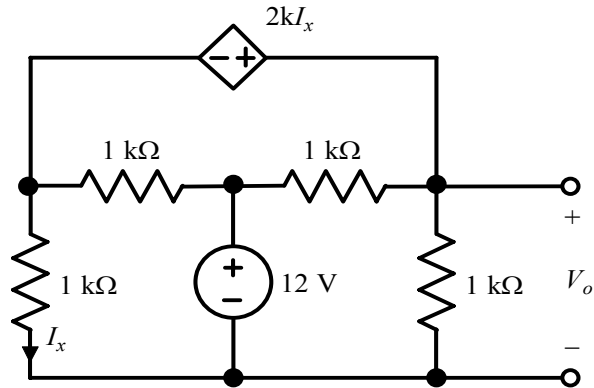

Suggested Solution

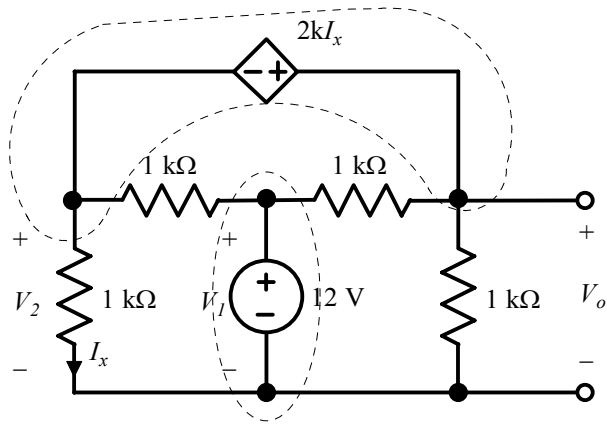

$$V_o - V_2 = 2kI_x \quad \Rightarrow \quad V_o - V_2 - 2kI_x = 0$$

$$V_1 = 12 \text{ V}$$

$$\frac{V_2 - V_1}{1 \text{ k}\Omega} + \frac{V_2}{1 \text{ k}\Omega} + \frac{V_o - V_1}{1 \text{ k}\Omega} + \frac{V_o}{1 \text{ k}\Omega} = 0 \quad \Rightarrow \quad V_o - V_1 + V_2 = 0$$

$$I_x = \frac{V_2}{1 \text{ k}\Omega} \quad \Rightarrow \quad V_2 - 1000I_x = 0$$

In matrix form:

Problem 3.36

Find I_0 in the circuit shown using nodal analysis.

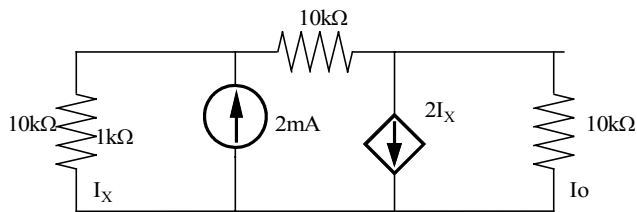

Suggested Solution

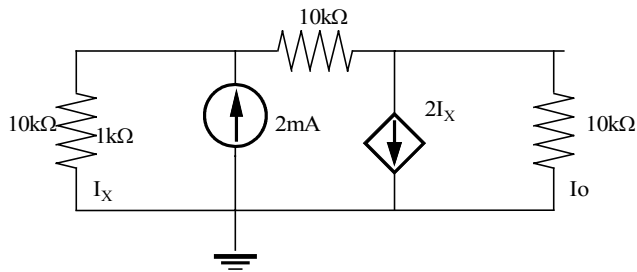

$$\frac{V_1}{10K} - \frac{2}{K} + \frac{V_1 - V_2}{10K} = 0$$

$$\frac{V_2 - V_1}{10K} + 2I_X + \frac{V_2}{10K} = 0$$

$$V_2 = -4V$$

$$I_0 = -0.4mA$$

$$V_2 = -4V$$

$$I_0 = -0.4mA$$

Problem 3.37

Find V_o in the network shown using nodal analysis.

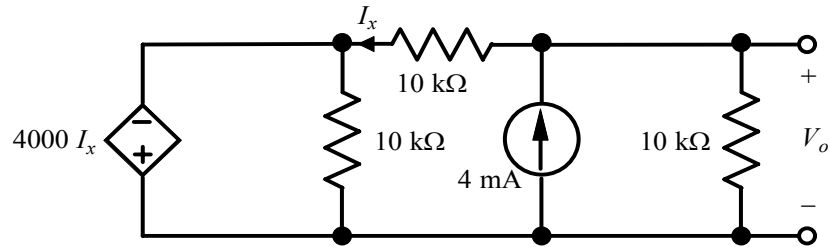

Suggested Solution

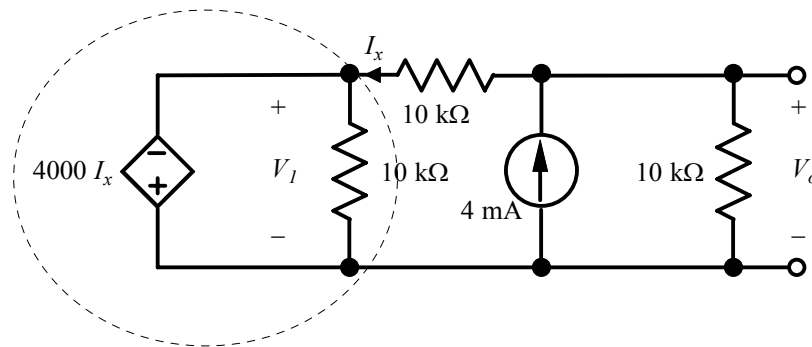

$$V_1 = -4000I_x \quad \Rightarrow \quad V_1 + 4000I_x = 0$$

$$\frac{V_o - V_1}{10 \text{ k}\Omega} - 4 \text{ mA} + \frac{V_o}{10 \text{ k}\Omega} = 0 \quad \Rightarrow \quad 2V_o - V_1 = 40$$

$$I_x = \frac{V_o - V_1}{10 \text{ k}\Omega} \quad \Rightarrow \quad V_o - V_1 - 10000I_x = 0$$

In matrix form:

$$\begin{bmatrix} 0 & 1 & 4000 \\ 2 & -1 & 0 \\ 1 & -1 & -10000 \end{bmatrix} \begin{bmatrix} V_o \\ V_1 \\ I_x \end{bmatrix} = \begin{bmatrix} 0 \\ 40 \\ 0 \end{bmatrix} \quad \Rightarrow \quad V_o = 15 \text{ V}$$

Problem 3.38

Find V_o in the network shown. In addition, determine all branch currents and check KCL at every node.

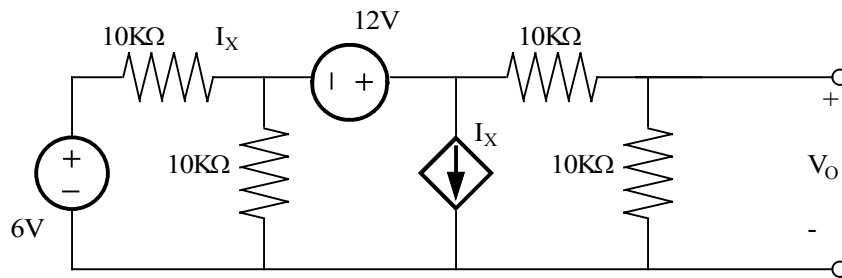

Suggested Solution

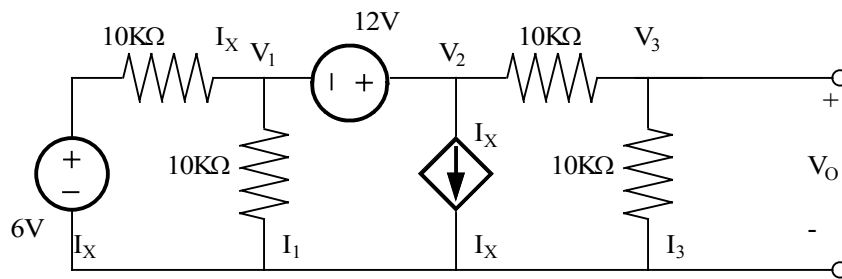

$$\frac{V_1 - 6}{10K} + \frac{V_1}{10K} + I_x + \frac{V_2}{20K} = 0$$

$$I_x = \frac{6 - V_1}{10K}$$

$$V_o = V_2 / 2$$

$$V_1 = -4V, V_2 = 8V, V_o = 4V$$

$$I_3 = \frac{V_o}{10K} = 0.4mA$$

$$I_x = \frac{6 - V_1}{10K} = 1mA$$

$$I_2 = I_3 + I_x = 1.4mA$$

$$I_1 = \frac{V_1}{10K} = -0.4mA$$

$$I_3 = \frac{V_0}{10K} = 0.4mA$$

$$I_x = \frac{6 - V_1}{10K} = 1mA$$

$$I_2 = I_3 + I_x = 1.4mA$$

$$I_1 = \frac{V_1}{10K} = -0.4mA$$

Problem 3.39

Find V_o in the circuit shown.

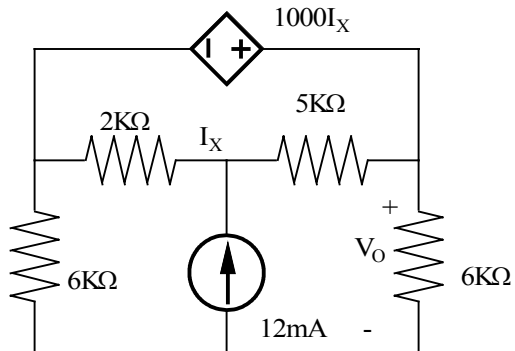

Suggested Solution

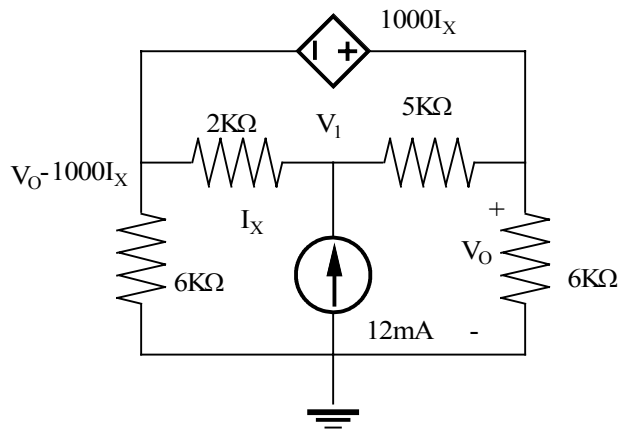

$$\frac{V_o - KI_x}{6K} + \frac{V_o - KI_x - V_1}{2K} + \frac{V_o - V_1}{5K} + \frac{V_o}{6K} = 0$$

$$I_x = \frac{V_o - KI_x - V_1}{2K}$$

$$V_o = 32.25$$

$$V_o = 32.25$$

Problem 3.40

Find V_o in the circuit shown.

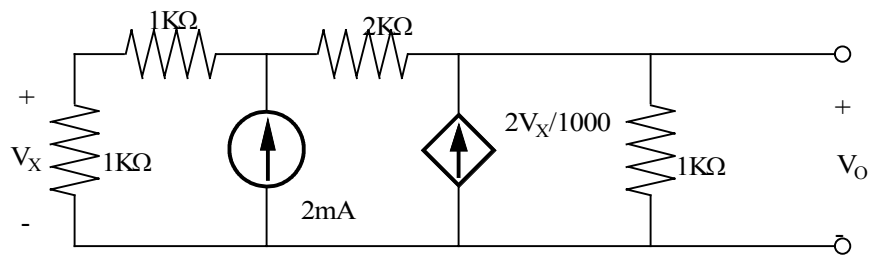

Suggested Solution

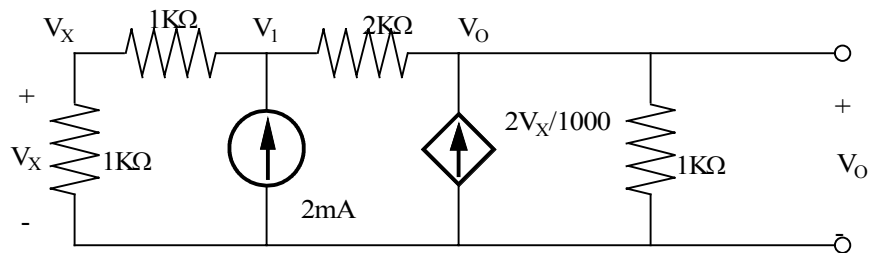

$$\frac{V_1}{2K} - \frac{2}{K} + \frac{V_1 - V_o}{2K} = 0$$

$$V_x = 1/2 V_1$$

$$\frac{V_o - V_1}{2K} - \frac{2V_x}{1K} + \frac{V_o}{1K} = 0$$

$$V_o = 4V$$

$$V_o = 4V$$

Problem 3.41

Use matlab to find the node voltages in the network shown.

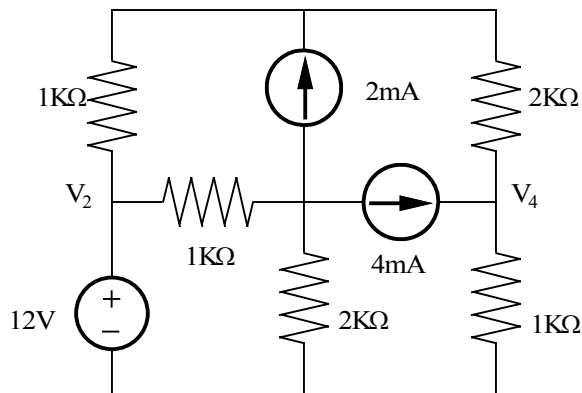

Suggested Solution

Applying _kcl

$$\frac{V_1 - V_2}{1K} - \frac{2}{K} + \frac{V_1 - V_4}{2K} = 0$$

$$V_2 = 12$$

$$\frac{V_3 - V_2}{1K} + \frac{2}{K} + \frac{4}{K} + \frac{V_3}{2K} = 0$$

$$\frac{V_4 - V_1}{2K} - \frac{4}{K} + \frac{V_4}{1K} = 0$$

MATRIX _ FORM

$$\begin{bmatrix} 0.0015 & -0.001 & 0 & -0.0005 \\ 0 & 1 & 0 & 0 \\ 0 & -0.001 & 0.0015 & 0 \\ -0.0005 & 0 & 0 & 0.0015 \end{bmatrix} \begin{bmatrix} V_1 \\ V_2 \\ V_3 \\ V_x \end{bmatrix} = \begin{bmatrix} 0.002 \\ 12 \\ -0.006 \\ 0.004 \end{bmatrix}$$

EDU» g=[0.0015 -0.001 0 -0.0005;0 1 0 0;0 -0.001 0.0015 0;-0.0005 0 0 0.0015]

g =

```

0.0015 -0.0010 0 -0.0005
0 1.0000 0 0
0 -0.0010 0.0015 0
-0.0005 0 0 0.0015
    
```

EDU» i=[0.002;12;-0.006;0.004]

i =

0.0020
12.0000
-0.0060
0.0040

EDU» v=inv(g)*i

v =

11.5000
12.0000
4.0000
6.5000

V =

11.5000
12.0000
4.0000
6.5000

Problem 3.42

Use mesh equations to find V_o in the circuit shown.

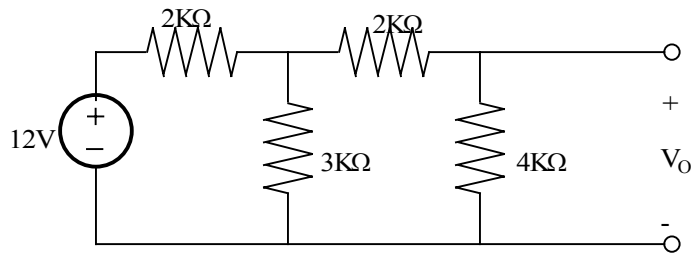

Suggested Solution

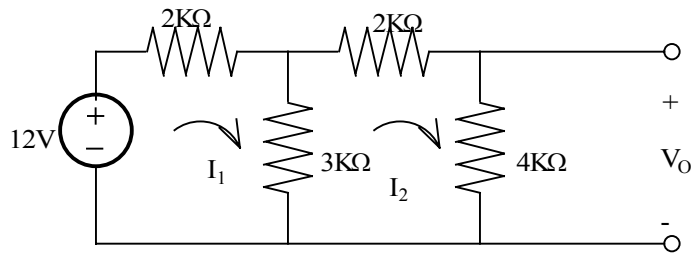

$$\begin{bmatrix} 5K & -3K \\ -3K & 4K \end{bmatrix} \begin{bmatrix} I_1 \\ I_2 \end{bmatrix} = \begin{bmatrix} 12 \\ 0 \end{bmatrix}$$

$$\begin{bmatrix} I_1 \\ I_2 \end{bmatrix} = \begin{bmatrix} 5K & -3K \\ -3K & 4K \end{bmatrix}^{-1} \begin{bmatrix} 12 \\ 0 \end{bmatrix}$$

$$I_2 = \frac{1}{K} A$$

$$V_o = 4V$$

$$V_o = 4V$$

Problem 3.43

Find V_o in the network shown using mesh equation.

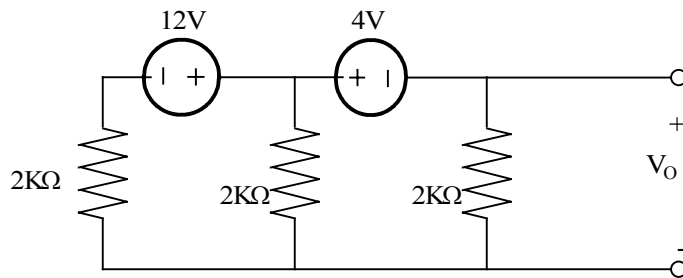

Suggested Solution

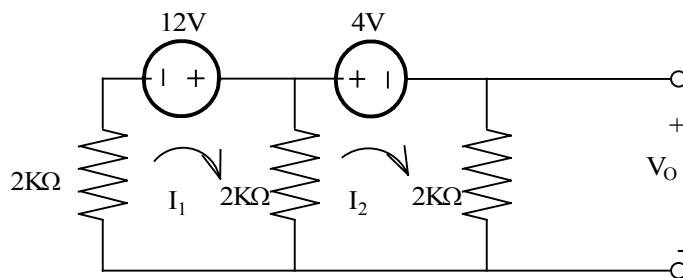

$$\begin{bmatrix} 4K & -2K \\ -2K & 4K \end{bmatrix} \begin{bmatrix} I_1 \\ I_2 \end{bmatrix} = \begin{bmatrix} 12 \\ -4 \end{bmatrix}$$

$$\begin{bmatrix} I_1 \\ I_2 \end{bmatrix} = \begin{bmatrix} 4K & -2K \\ -2K & 4K \end{bmatrix}^{-1} \begin{bmatrix} 12 \\ -4 \end{bmatrix}$$

$$I_2 = \frac{2}{3K} A$$

$$V_o = \frac{4}{3} V$$

$$V_o = \frac{4}{3} V$$

Problem 3.44

Use mesh analysis to find V_o in the circuit shown.

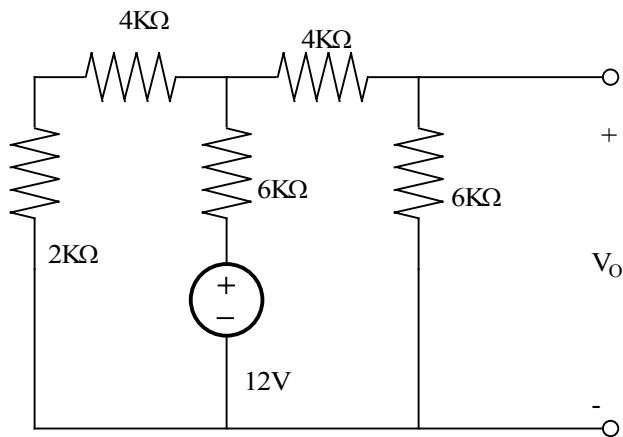

Suggested Solution

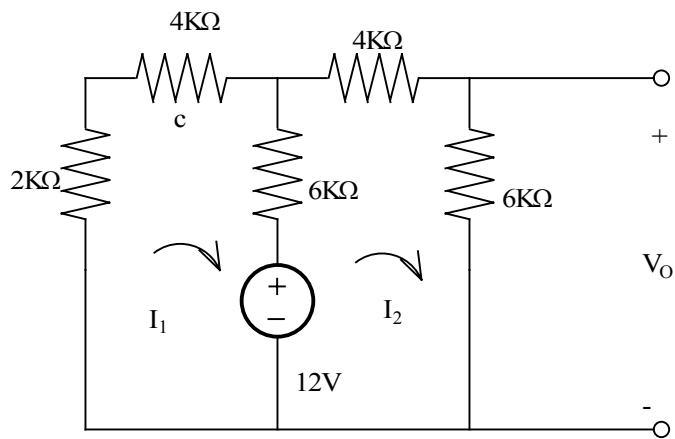

$$\begin{bmatrix} 12K & -6K \\ -6K & 12K \end{bmatrix} \begin{bmatrix} I_1 \\ I_2 \end{bmatrix} = \begin{bmatrix} -12 \\ 12 \end{bmatrix}$$

$$\begin{bmatrix} I_1 \\ I_2 \end{bmatrix} = \begin{bmatrix} 12K & -6K \\ -6K & 12K \end{bmatrix}^{-1} \begin{bmatrix} -12 \\ 12 \end{bmatrix}$$

$$I_2 = \frac{2}{3} \text{ mA}$$

$$V_o = \frac{4}{3} \text{ V}$$

$$V_o = \frac{4}{3} \text{ V}$$

Problem 3.45

Use mesh analysis to find V_o in the network shown.

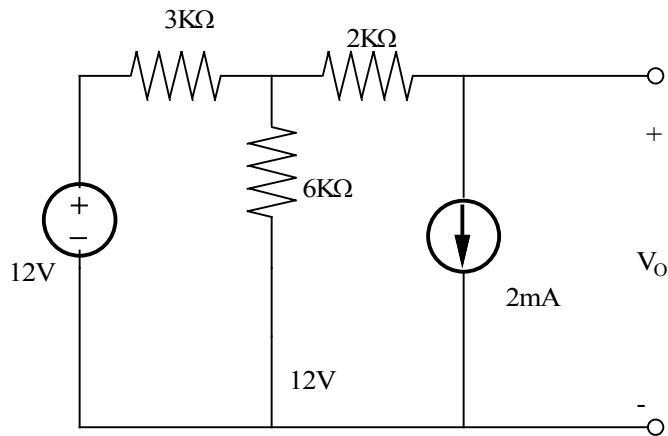

Suggested Solution

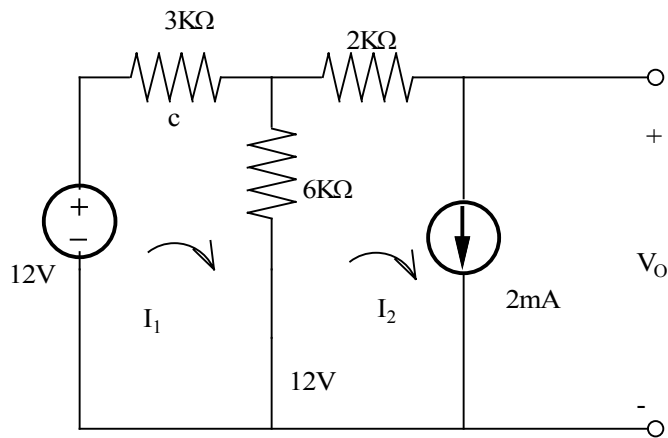

$$-12 + 3KI_1 + K(I_1 - I_2) = 0$$

$$I_2 = \frac{2}{K}$$

$$I_1 = \frac{8}{3K}$$

$$-12 + 3K\left(\frac{8}{3K}\right) + 2K\left(\frac{2}{K}\right) = V_o = 0V$$

$$V_o = 0V$$

Problem 3.46

Use loop analysis to find V_o in the circuit shown.

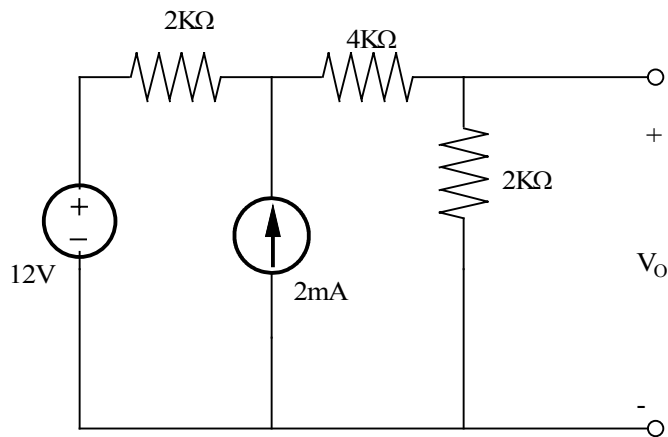

Suggested Solution

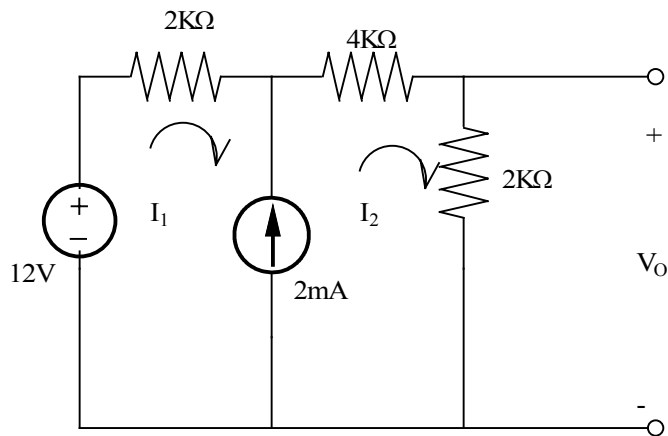

$$12 = 2KI_1 + 6KI_2$$

$$I_2 - I_1 = \frac{2}{K}$$

$$I_2 = \frac{2}{K}$$

$$V_o = (2K)\left(\frac{2}{K}\right) = 4V$$

$$V_o = 4V$$

$$V_o = 4V$$

Problem 3.47

Use loop analysis to find I_0 in the circuit shown.

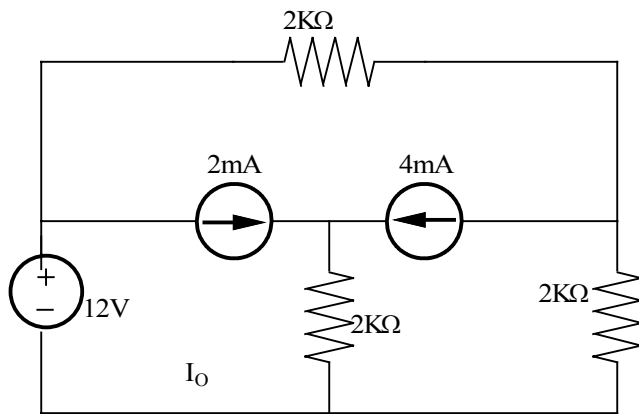

Suggested Solution

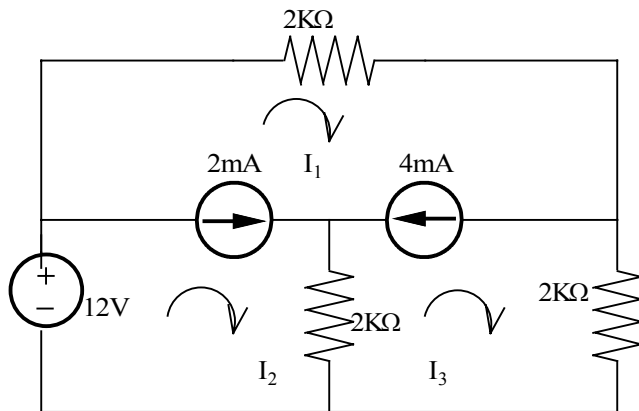

$$12 = 2KI_2 + 2KI_3$$

$$I_1 - I_2 = \frac{2}{K}$$

$$I_2 - I_3 = \frac{4}{K}$$

$$I_1 = I_0 = 7mA$$

$$I_1 = I_0 = 7mA$$

Problem 3.48

Use both nodal analysis and mesh analysis to find I_0 in the circuit shown.

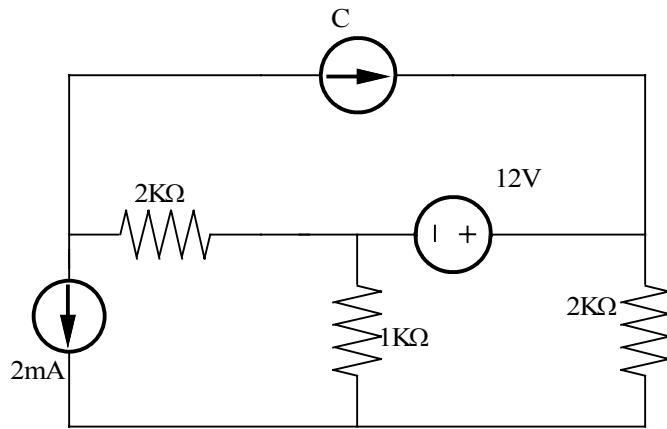

Suggested Solution

$$\frac{2}{K} + \frac{4}{K} \frac{V_1 - V_2}{2K} = 0$$

$$\frac{V_2 - V_1}{2K} + \frac{V_2}{1K} + \frac{V_3}{2K} - \frac{4}{K} = 0$$

Where

$$V_3 - V_2 = 12$$

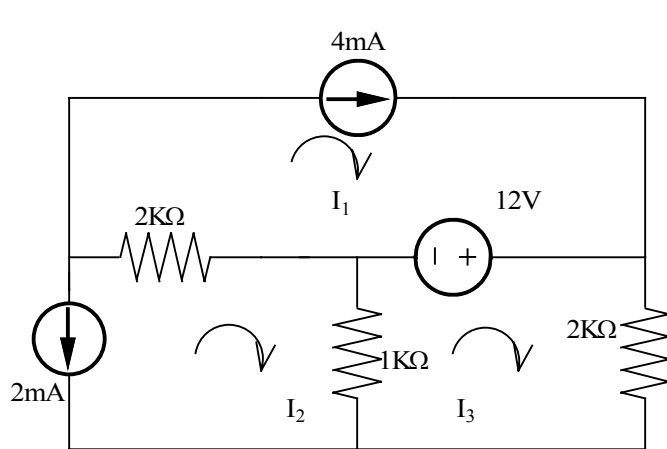

$$V_2 = \frac{-16}{3} V$$

$$I_0 = -5.33 mA$$

$$I_1 = \frac{-2}{K}, I_2 = \frac{4}{K}$$

$$1K(I_1 - I_3) - 12 + 2KI_3 = 0$$

$$I_3 = \frac{10}{3K}$$

$$I_0 = I_1 - I_3 = -5.33 mA$$

$$I_0 = I_1 - I_3 = -5.33 mA$$

Problem 3.49

Find I_0 in the network shown using mesh analysis.

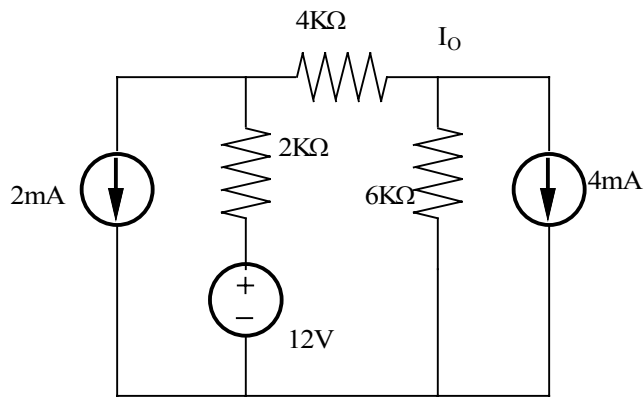

Suggested Solution

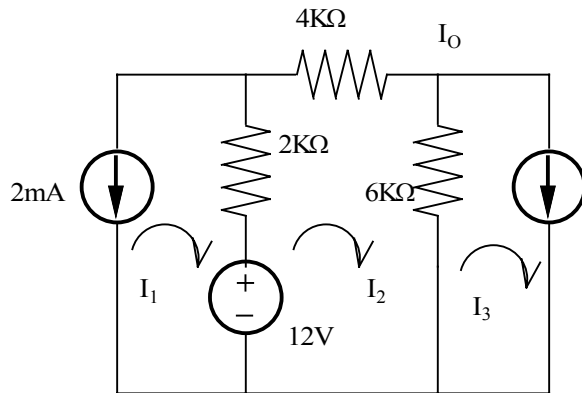

$$I_1 = \frac{-2}{K}$$

$$I_3 = \frac{4}{K}$$

$$-12 + 2K(I_2 - I_1) + 4KI_2 + 6K(I_2 - I_3) = 0$$

$$I_2 = \frac{16}{6} mA$$

$$I_0 = I_2 = 2.67 mA$$

$$I_0 = I_2 = 2.67 mA$$

Problem 3.50

Find I_0 in the network shown using mesh analysis.

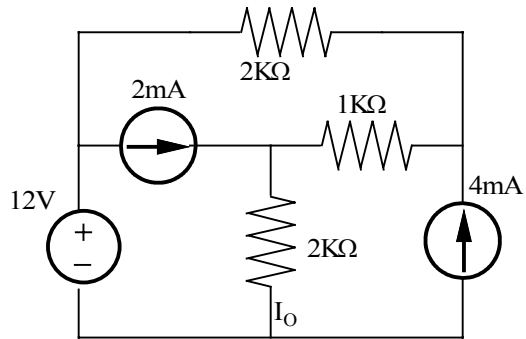

Suggested Solution

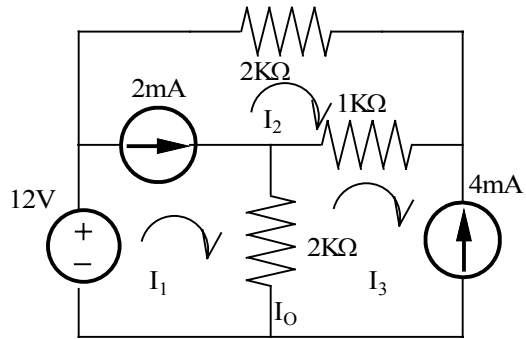

$$-12 + 2K(I_1 - I_3) + 2KI_2 + 1K(I_2 - I_3) = 0$$

$$I_1 - I_2 = \frac{2}{K}$$

$$I_3 = \frac{-4}{K}$$

$$I_1 = \frac{6}{5K} A$$

$$I_0 = I_1 - I_3 = 5.2mA$$

$$I_0 = I_1 - I_3 = 5.2mA$$

Problem 3.51

Find V_o in the circuit shown using mesh analysis.

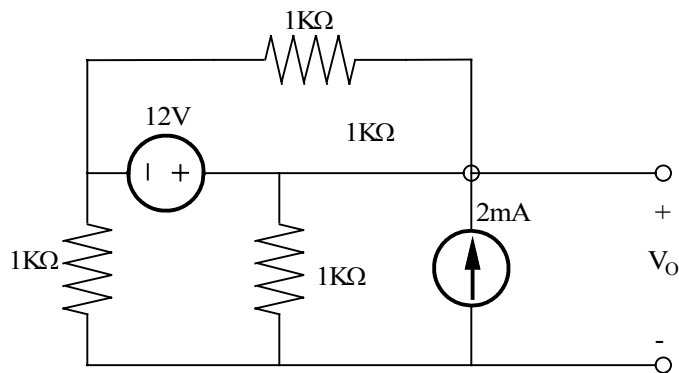

Suggested Solution

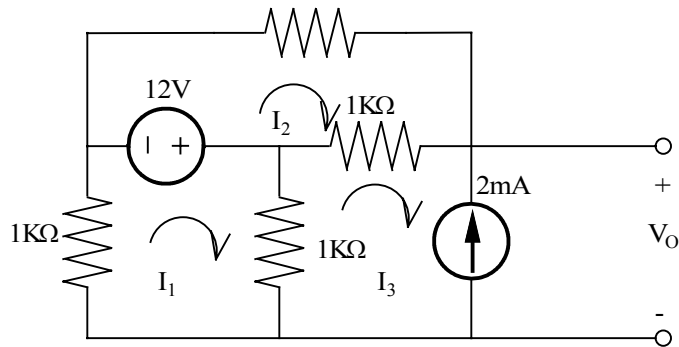

$$2KI_1 - 1KI_3 = -12$$

$$2KI_2 - 1KI_3 = 12$$

$$I_3 = \frac{-2}{K}$$

\Rightarrow

$$2KI_1 + 2 = -12$$

$$2KI_2 + 2 = 12$$

$$I_1 = \frac{-7}{K}, I_2 = \frac{5}{K}$$

$$V_o = \frac{7}{K}(1K) - \frac{5}{K}(1K) = 2V$$

$$V_o = 2V$$

$$V_o = 2V$$

Problem 3.52

Use loop analysis to find V_o in the network shown.

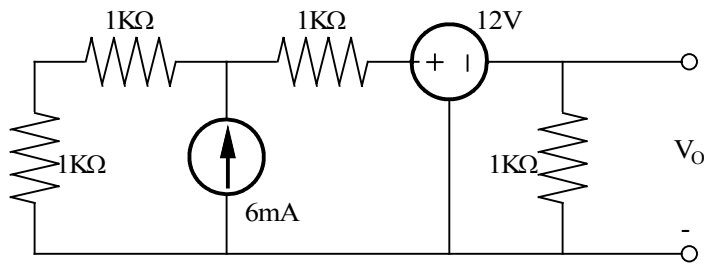

Suggested Solution

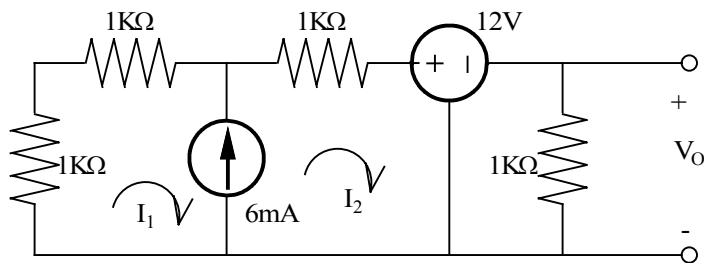

$$I_1 = \frac{-6}{K}$$

$$1K(I_1 + I_2) + 1K(I_1 + I_2) + 1KI_2 + 12 + 1KI_2 = 0$$

$$I_2 = 0$$

$$V_o = 0$$

$$V_o = 0$$

Problem 3.53

Find I_o in the network shown using loop analysis. Then solve the problem using matlab and compare your answers.

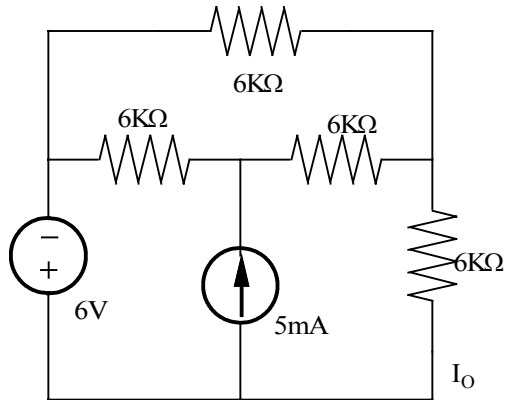

Suggested Solution

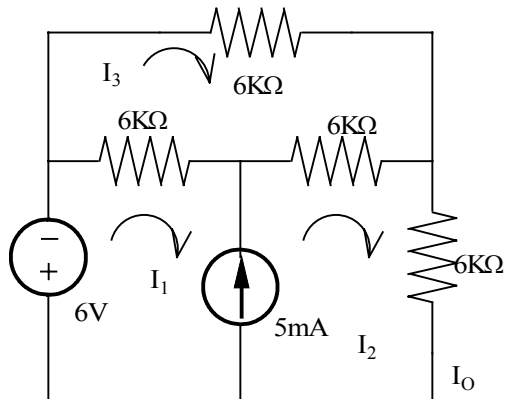

$$6 + 6K(I_1 - I_3) + 6K(I_2 - I_3) + 6KI_2 = 0$$

$$6KI_3 + 6K(I_3 - I_2) + 6K(I_3 - I_1) = 0$$

$$I_2 - I_1 = \frac{5}{K}$$

$$\begin{bmatrix} 6K & 12K & -12K \\ -6K & -6K & 18K \\ -1K & 1K & 0 \end{bmatrix} \begin{bmatrix} I_1 \\ I_2 \\ I_3 \end{bmatrix} = \begin{bmatrix} -6 \\ 0 \\ 5 \end{bmatrix}$$

Using Matlab

```
EDU>> Z=[6000 12000 -12000;-6000 -6000 18000;-1000 1000 0]
```

Z =

```

    6000    12000   -12000
   -6000    -6000    18000
   -1000     1000         0

```

EDU» V=[-6;0;5]

V =

-6
0
5

EDU» I=inv(Z)*V

I =

-0.0046
0.0004
-0.0014

Problem 3.54

Use loop analysis to find I_0 in the circuit shown.

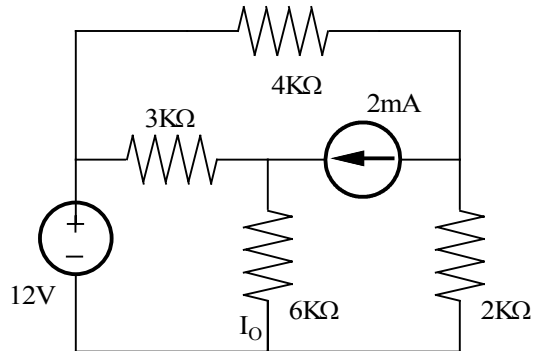

Suggested Solution

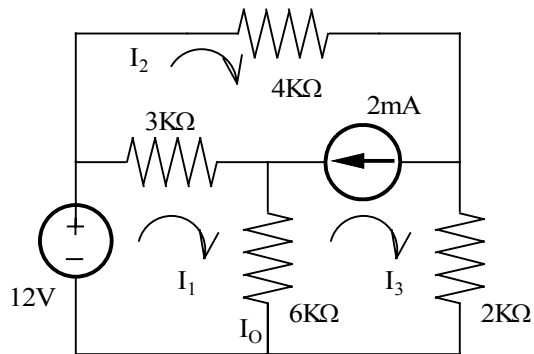

$$-12 + 3K(I_1 - I_2) + 6KI_2 = 0$$

$$I_2 = \frac{2}{K}$$

$$9KI_1 = 18$$

$$I_1 = I_0 = 2mA$$

$$I_1 = I_0 = 2mA$$

Problem 3.55

Find V_o in the network shown using both mesh and nodal analysis.

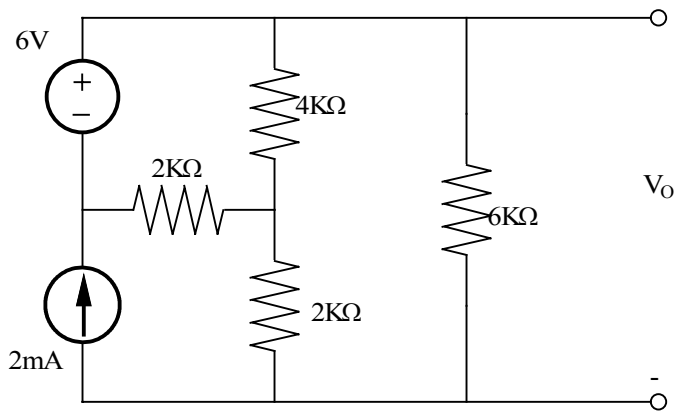

Suggested Solution

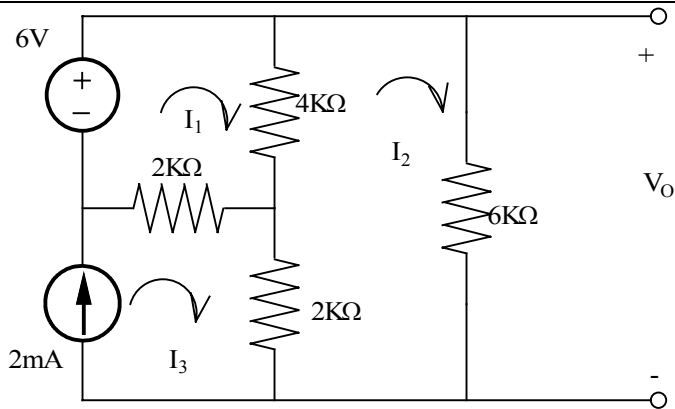

$$I_3 = \frac{2}{K}$$

$$6 = 6KI_1 - 4KI_2 - 2KI_3$$

$$0 = -4KI_1 + 12KI_2 - 2KI_3$$

$$V_o = 6.86V$$

$$I_2 = 1.14mA$$

$$V_o = 6KI_2 = 6.86V$$

$$\frac{V_1 - V_2}{2K} + \frac{V_3 - V_2}{4K} = \frac{V_2}{2K} \Rightarrow 2V_1 + V_3 - 5V_2 = 0$$

$$\frac{V_2}{2K} + \frac{V_3}{6K} = \frac{2}{K} \Rightarrow 3V_2 + V_3 = 12$$

$$V_3 = V_o = 6.86V$$

$$V_3 - V_1 = 6$$

Problem 3.56

Use loop analysis to find V_o in the circuit shown.

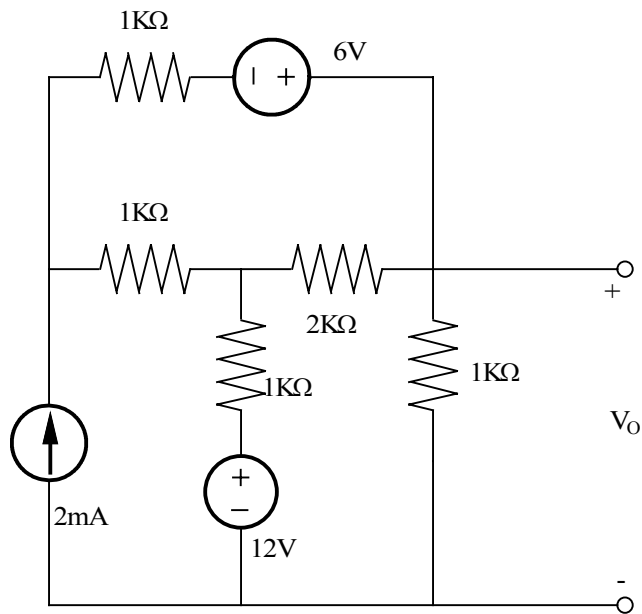

Suggested Solution

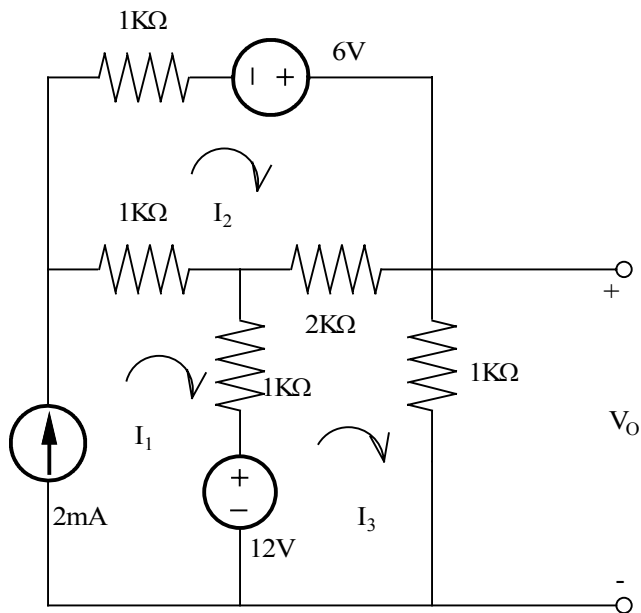

$$I_1 = \frac{2}{K}$$

$$1KI_2 - 6 + 2K(I_2 - I_3) + 1K(I_2 - I_1) = 0$$

$$-12 + 1K(I_3 - I_1) + 2K(I_3 - I_2) + 1K(I_3) = 0$$

$$\begin{bmatrix} 4K & -2K \\ -2K & 4K \end{bmatrix} \begin{bmatrix} I_2 \\ I_3 \end{bmatrix} = \begin{bmatrix} 8 \\ 14 \end{bmatrix}$$

$$6KI_3 = 36$$

$$I_3 = 6mA$$

$$V_0 = 6V$$

$$I_3 = 6mA$$

$$V_0 = 6V$$

Problem 3.57

Use loop analysis to find I_o in the network shown.

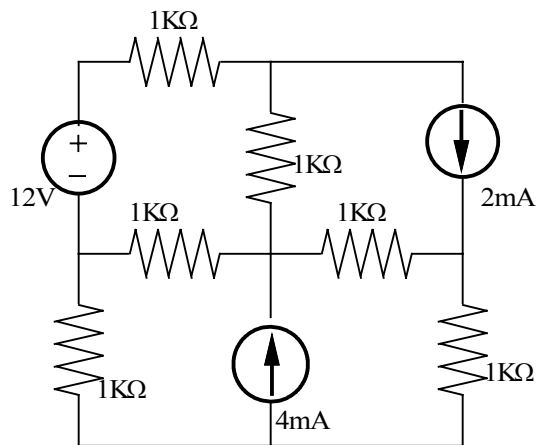

Suggested Solution

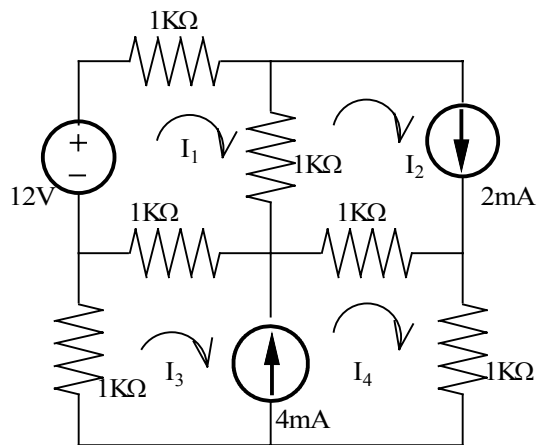

$$-12 + 1K(I_1 - I_2) + 1K(I_1 - I_3 - I_4) + 1K(I_1) = 0$$

$$I_2 = \frac{2}{K}$$

$$I_3 = \frac{-4}{K}$$

$$1K(I_3 + I_4) + 1K(I_3 + I_4 - I_1) + 1K(I_4 - I_2) + 1KI_4 = 0$$

$$3KI_1 - 1KI_4 = 10$$

$$-1KI_1 + 4KI_4 = 10$$

$$I_o = I_4 - I_2 = 1.64mA$$

$$I_4 = \frac{40}{11K} A$$

$$I_o = I_4 - I_2 = 1.64mA$$

Problem 3.58

Use loop analysis to find V_o in the network shown.

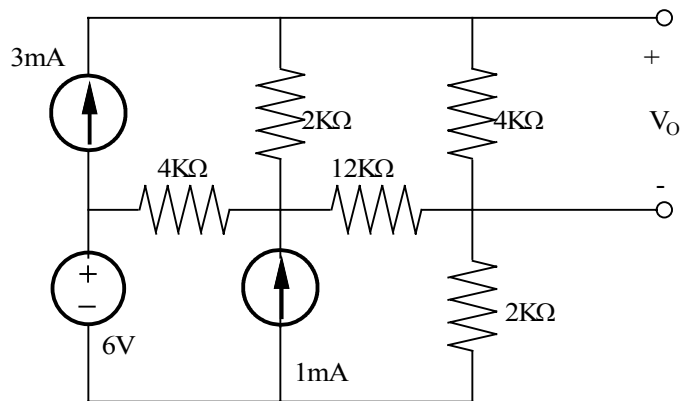

Suggested Solution

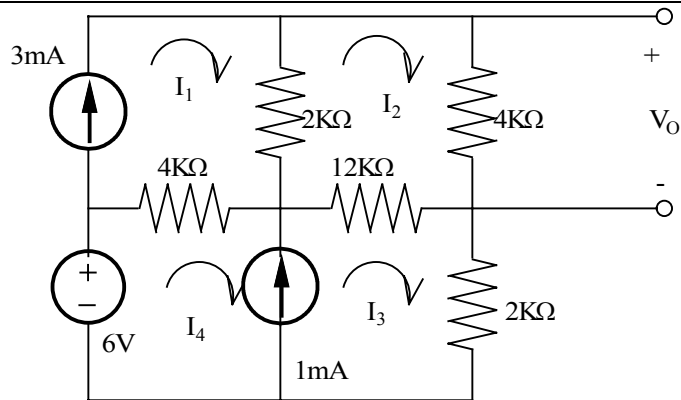

$$I_1 = \frac{3}{K}$$

$$I_3 - I_4 = \frac{1}{K}$$

$$-6 + 4K(I_4 - I_1) + 12K(I_3 - I_2) + 2KI_3$$

$$0 = -2KI_1 - 12KI_3 + 18KI_2$$

$$I_2 = \frac{31}{15K} A$$

$$V_o = 4I_2 = 8.27V$$

$$V_o = 4I_2 = 8.27V$$

Problem 3.59

Find V_o in the network shown.

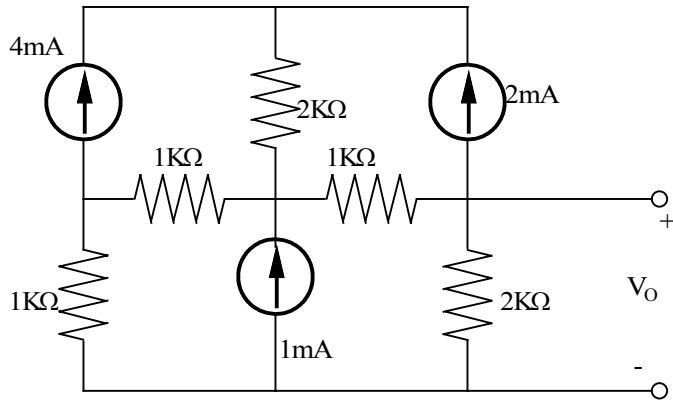

Suggested Solution

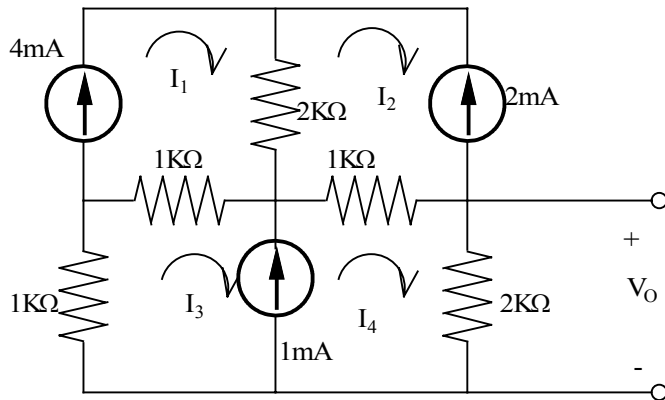

$$I_1 = \frac{4}{K}, I_2 = \frac{-2}{K}, I_3 = \frac{-1}{K}$$

$$1K(I_3 + I_4) + 1K(I_3 + I_4 - I_1) + 1K(I_4 - I_2) + 2KI_4 = 0$$

$$5KI_4 = 4$$

$$I_4 = \frac{4}{5K}$$

$$V_o = \frac{8}{5}V$$

$$V_o = \frac{8}{5}V$$

Problem 3.60

Find V_o in the circuit shown.

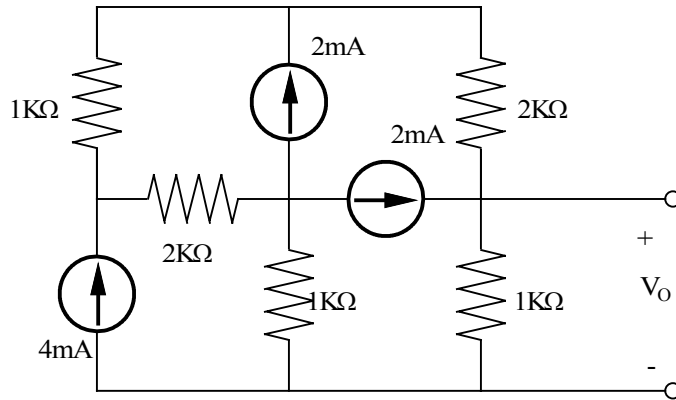

Suggested Solution

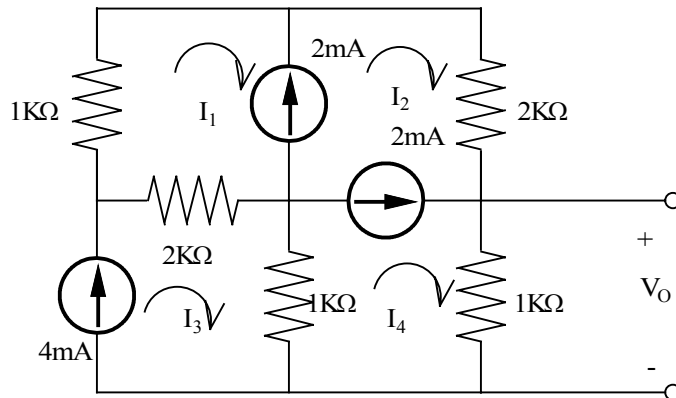

$$0 = 2KI_2 + 1KI_4 + 1K(I_4 - I_3) + 2K(I_1 - I_3) + 1KI_1 = 0$$

$$I_3 = \frac{4}{K}, I_4 - I_2 = \frac{2}{K}, I_2 - I_1 = \frac{2}{K}$$

$$I_4 = \frac{4}{K}$$

$$V_o = 1KI_4 = 4V$$

$$V_o = 1KI_4 = 4V$$

Problem 3.61

Find I_0 in the circuit shown.

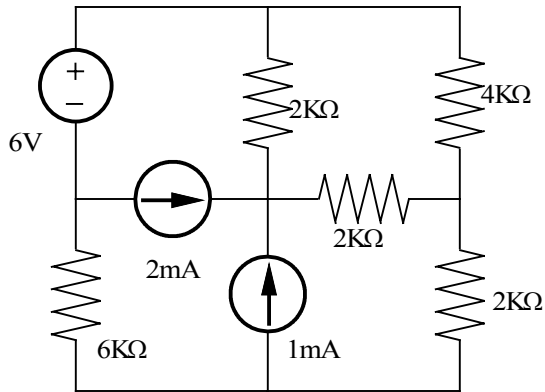

Suggested Solution

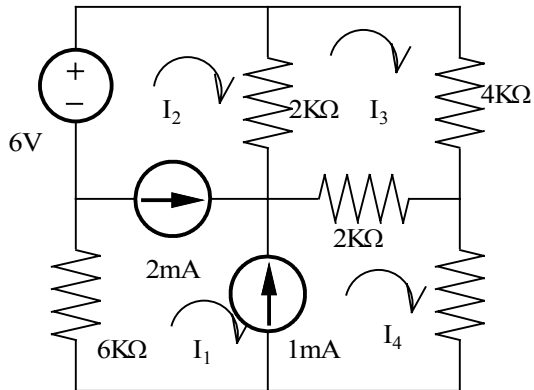

$$6 = 4KI_3 + 2KI_4 + 6KI_1$$

$$0 = -2KI_2 - 2KI_4 + 8KI_3$$

$$I_1 - I_2 = \frac{2}{K}, I_4 - I_1 = \frac{1}{K}$$

$$I_2 = -1.5mA$$

$$I_3 = 0$$

$$I_0 = I_2 - I_3 = -1.5mA$$

$$I_0 = I_2 - I_3 = -1.5mA$$

Problem 3.62

Use loop analysis to find V_o in the network shown.

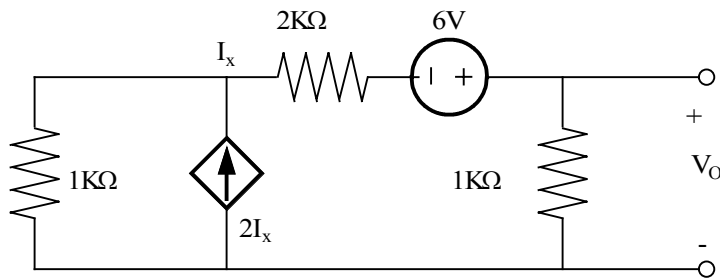

Suggested Solution

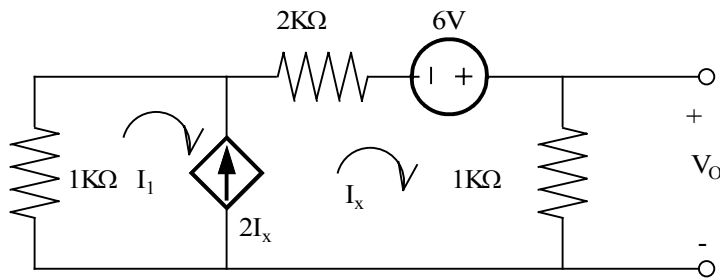

$$I_1 = -2I_x$$

$$1K(I_1 + I_x) + 2KI_x - 6 + 1KI_x = 0$$

$$I_x = \frac{3}{K} A$$

$$V_o = 3V$$

$$V_o = 3V$$

Problem 3.63

Use mesh analysis to find V_o in the circuit shown.

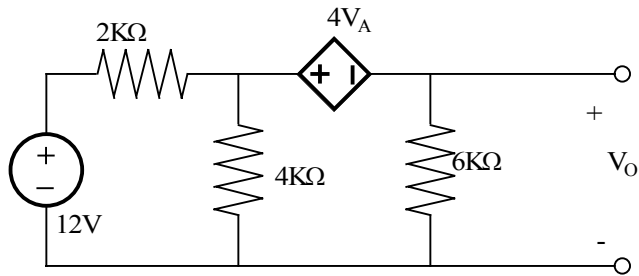

Suggested Solution

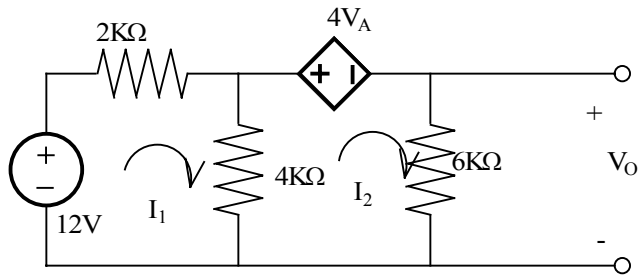

$$12 = 6KI_1 - 4KI_2$$

$$0 = -4KI_1 + 10KI_2 + 4V_A$$

$$V_A = 2KI_1$$

$$I_2 = -0.63mA$$

$$V_o = 6KI_2 = -3.79V$$

$$V_o = 6KI_2 = -3.79V$$

Problem 3.64

Use loop analysis to find V_o in the circuit shown.

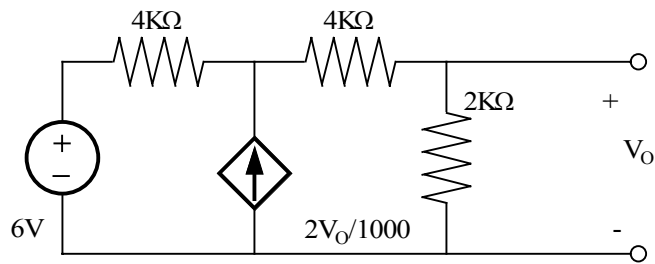

Suggested Solution

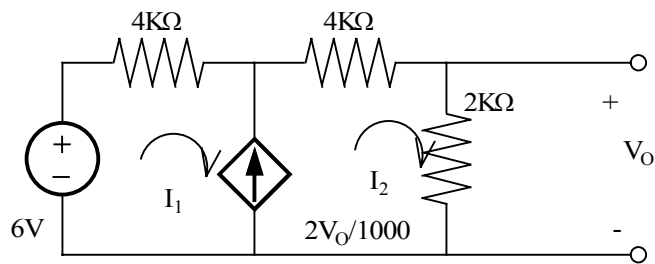

$$I_2 - I_1 = \frac{2V_o}{K}, V_o = 2KI_2$$

$$6 = 4KI_1 + 6KI_2$$

$$I_2 = -1mA$$

$$V_o = 2KI_2 = -2V$$

$$V_o = 2KI_2 = -2V$$

Problem 3.65

Find V_o in the circuit shown using mesh analysis.

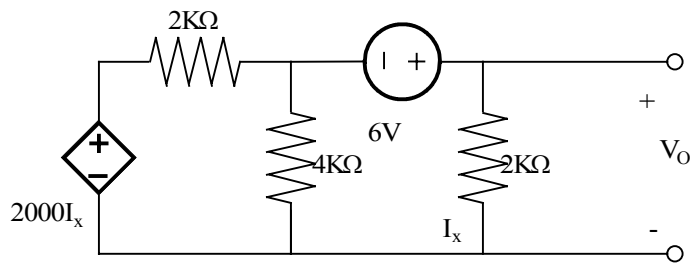

Suggested Solution

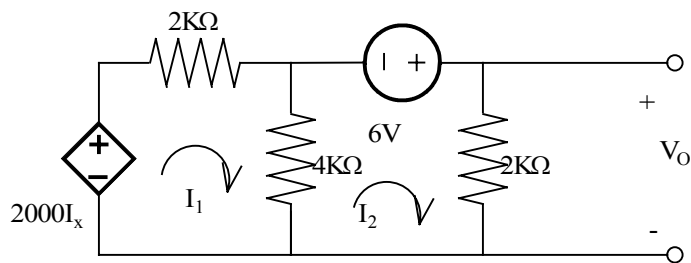

$$I_2 = I_x$$

$$2KI_x = 6KI_1 - 4KI_2$$

$$6 = -4KI_1 + 6KI_2$$

$$I_2 = 3mA$$

$$V_o = 2KI_2 = 6V$$

$$V_o = 2KI_2 = 6V$$

Problem 3.66

Use both nodal analysis and mesh analysis to find V_o in the circuit shown.

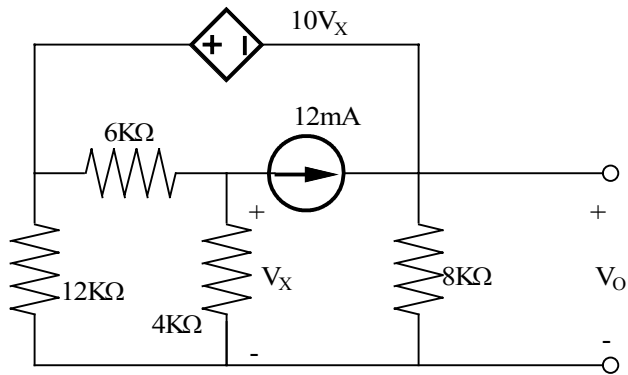

Suggested Solution

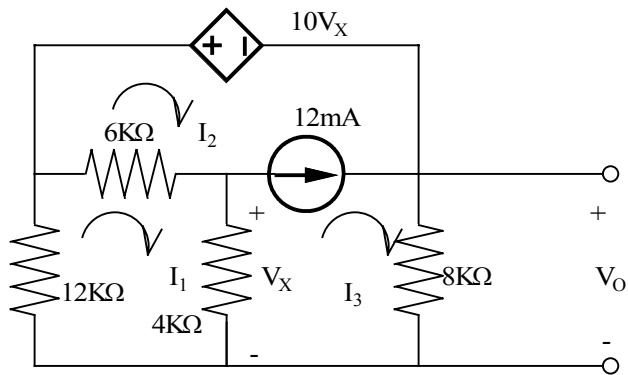

$$22KI_1 - 6KI_2 - 4KI_3 = 0$$

$$12KI_1 + 10V_x + 8KI_3 = 0$$

$$V_x = 4K(I_1 - I_3)$$

$$I_3 - I_2 = \frac{12}{K}$$

$$I_3 = -20.35mA$$

$$V_0 = 8KI_3 = -162.78V$$

Nodal _ Analysis

$$\frac{V_2 - V_1}{6K} + \frac{V_2}{4K} + \frac{12}{K} = 0$$

$$\frac{V_1}{12K} + \frac{V_2}{4K} + \frac{V_3}{8K} = 0$$

$$V_1 - V_3 = 10V_x$$

$$V_x = V_2$$

$$V_3 = V_0 = -162.78V$$

$$V_3 = V_0 = -162.78V$$

Problem 3.67

Using mesh analysis finds V_o in the circuit shown

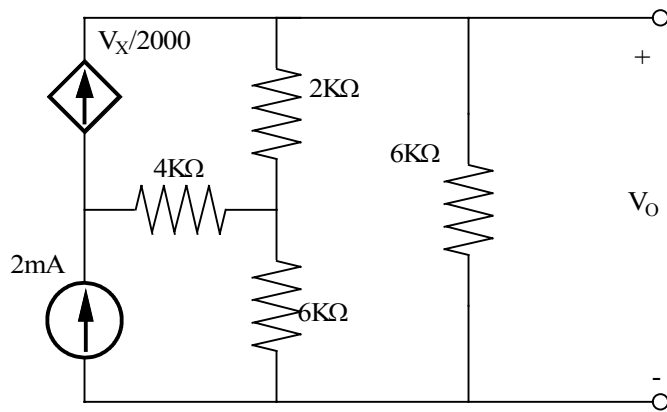

Suggested Solution

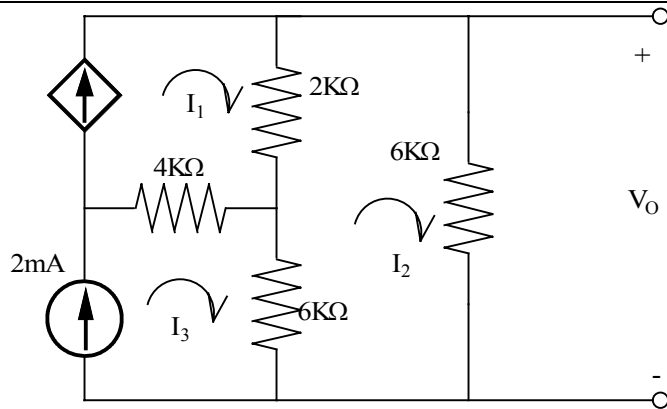

$$I_1 = \frac{V_X}{2K}, R_3 = \frac{2}{K}, V_X = (I_3 - I_2)6K$$

$$(I_2 - I_3)6K + (I_2 - I_1)2K + 6KI_2 = 0$$

$$I_2 = \frac{6}{5K} A$$

$$V_o = 6KI_2 = \frac{36}{5} V$$

$$V_o = 6KI_2 = \frac{36}{5} V$$

Problem 3.68

Find V_o in the network shown.

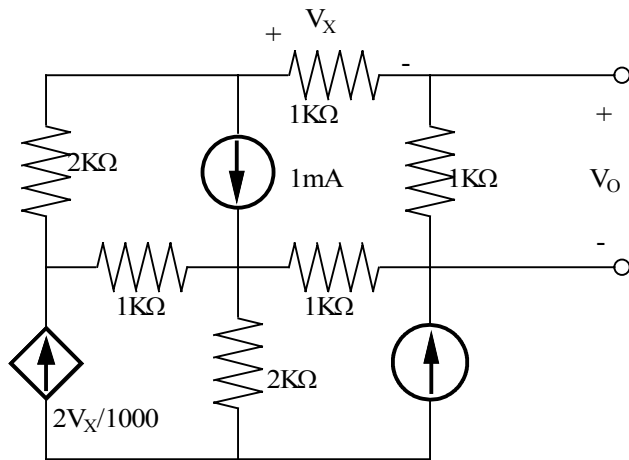

Suggested Solution

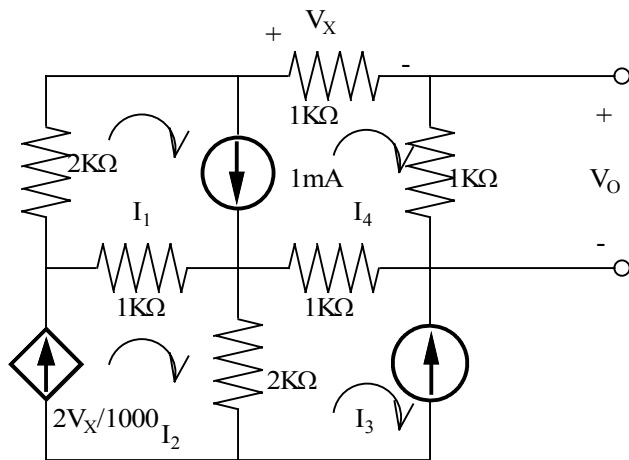

$$I_1 = \frac{1}{2K}, I_2 = \frac{2}{K}, V_x = -1KI_4, I_3 = \frac{-4}{K}$$

$$2K(I_1 + I_4) + 1KI_4 + 1KI_4 + 1K(I_4 - I_3) + 1K(I_4 + I_1 - I_2) = 0$$

$$I_2 = -2I_4$$

$$I_4 = \frac{-7}{8K}$$

$$V_o = \frac{-7}{8}V$$

$$V_o = \frac{-7}{8}V$$

Problem 3.69

Use matlab to find the mesh currents in the network shown.

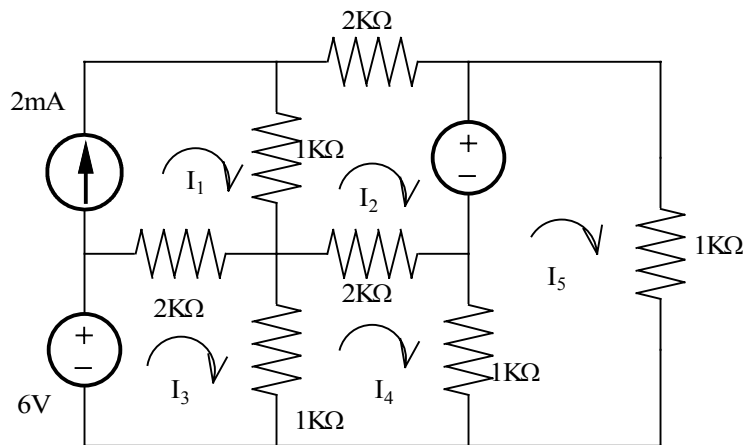

Suggested Solution

$$I_1 = \frac{2}{K}$$

$$-I_1(1K) + I_2(5K) - I_4(2K) = -12$$

$$-I_1(2K) - I_4(1K) + I_3(3K) = 6$$

$$-I_3(1K) - I_2(2K) + I_4(4K) - I_5(1K) = 0$$

$$-I_4(1K) + I_5(2K) = 12$$

$$\begin{bmatrix} 1 & 0 & 0 & 0 & 0 \\ -1000 & 5000 & 0 & -2000 & 0 \\ -2000 & 0 & 3000 & -1000 & 0 \\ 0 & -2000 & -1000 & 4000 & -1000 \\ 0 & 0 & 0 & -1000 & 2000 \end{bmatrix} \begin{bmatrix} I_1 \\ I_2 \\ I_3 \\ I_4 \\ I_5 \end{bmatrix} = \begin{bmatrix} 0.002 \\ -12 \\ 6 \\ 0 \\ 12 \end{bmatrix}$$

```
EDU>> r=[1 0 0 0 0;-1000 5000 0 -2000 0;-2000 0 3000 -1000 0;0 -2000 -1000 4000 -1000;0 0 0 -1000 2000]
```

Using Matlab

r =

```

1      0      0      0      0
-1000  5000   0    -2000   0
-2000   0    3000  -1000   0
 0    -2000  -1000  4000  -1000
 0      0      0   -1000  2000
```

```
EDU>> v=[0.002;-12;6;0;12]
```

v =

0.0020
-12.0000
6.0000
0
12.0000

EDU» i=inv(r)*v

i =

0.0020
-0.0011
0.0041
0.0023
0.0071

Problem 3.70

Find V_o in the circuit shown.

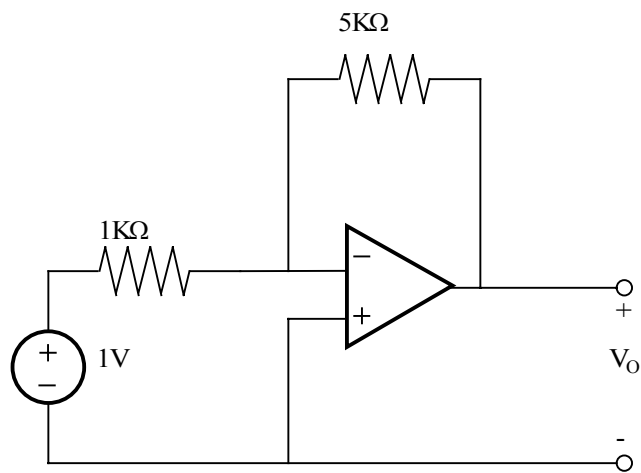

Suggested Solution

KCL at the intersecting input

$$\frac{1-0}{0.1K} = \frac{0-V_o}{5K}$$
$$V_o = -5V$$

$$V_o = -5V$$

Problem 3.71

Find V_o in the network shown and explain what effect R_1 has on the output.

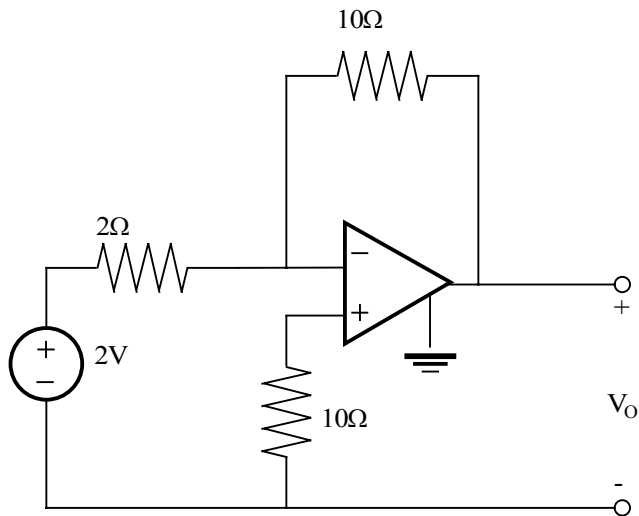

Suggested Solution

No current in R_1 . It has no effect. KCL at the inverting input.

$$\frac{2-0}{2} = \frac{0-V_o}{10}$$

$$V_o = -10V$$

$$V_o = -10V$$

Problem 3.72

Find V_o in the network shown.

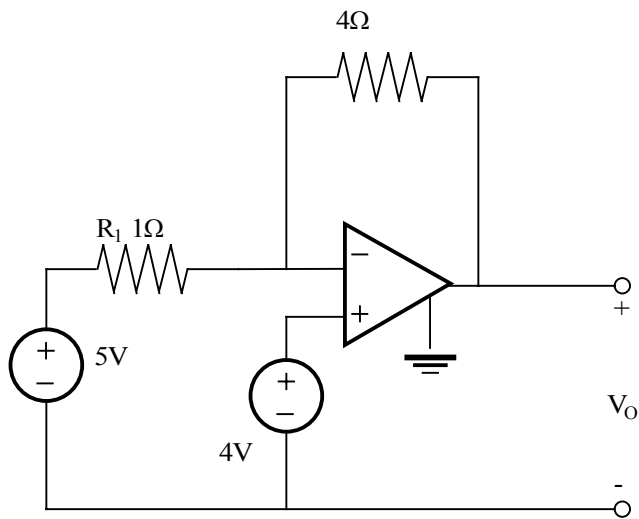

Suggested Solution

KCL at the inverting input is

$$\frac{5-4}{1} = \frac{4-V_o}{4}$$

$$V_o = 0V$$

Problem 3.73

The network shown is a current-to-voltage converter or transresistance amplifier. Find V_o/i_s for this network.

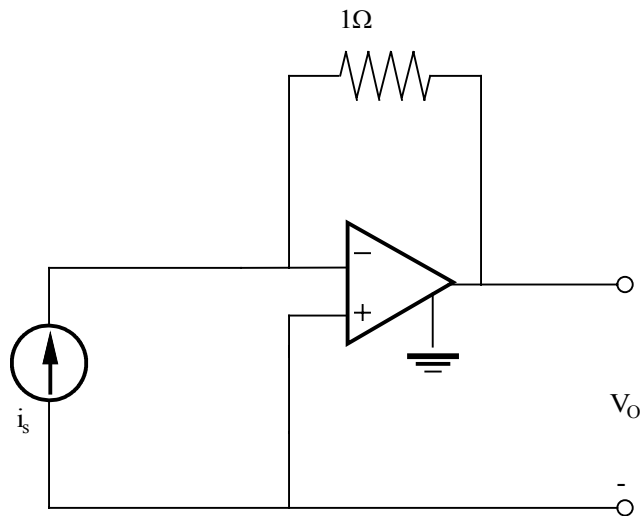

Suggested Solution

KCL at the inverting input is

$$\frac{5-4}{1} = \frac{0-V_o}{1}$$

$$\frac{V_o}{i_s} = -1$$

$$\frac{V_o}{i_s} = -1$$

Problem 3.74

Find V_o in the circuit shown.

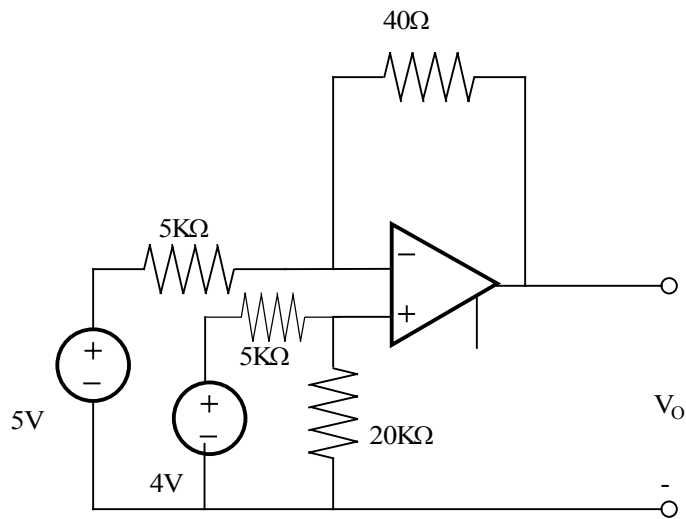

Suggested Solution

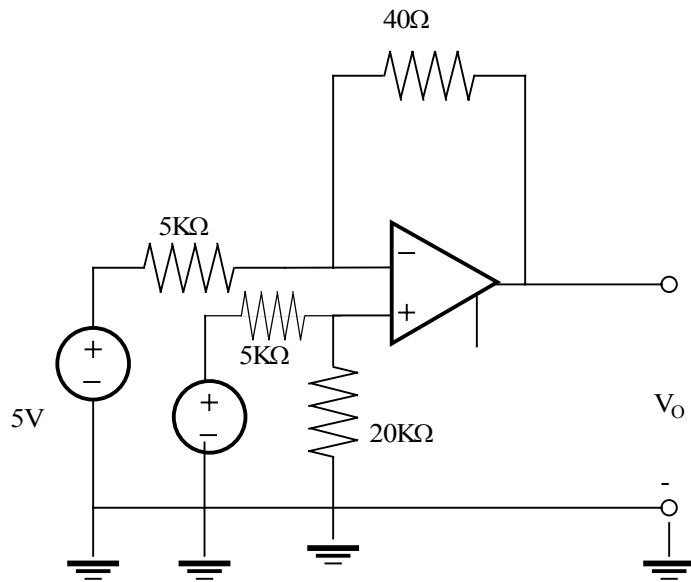

Applying Voltage Division

$$V_x = 4 \left(\frac{20}{20+5} \right) = 3.2V$$

KCL at the inverting input

$$\frac{5 - V_x}{5K} = \frac{V_x - V_o}{40K}$$

$$V_o = -11.2V$$

$$V_o = -11.2V$$

Problem 3.75

Find V_o in the circuit shown.

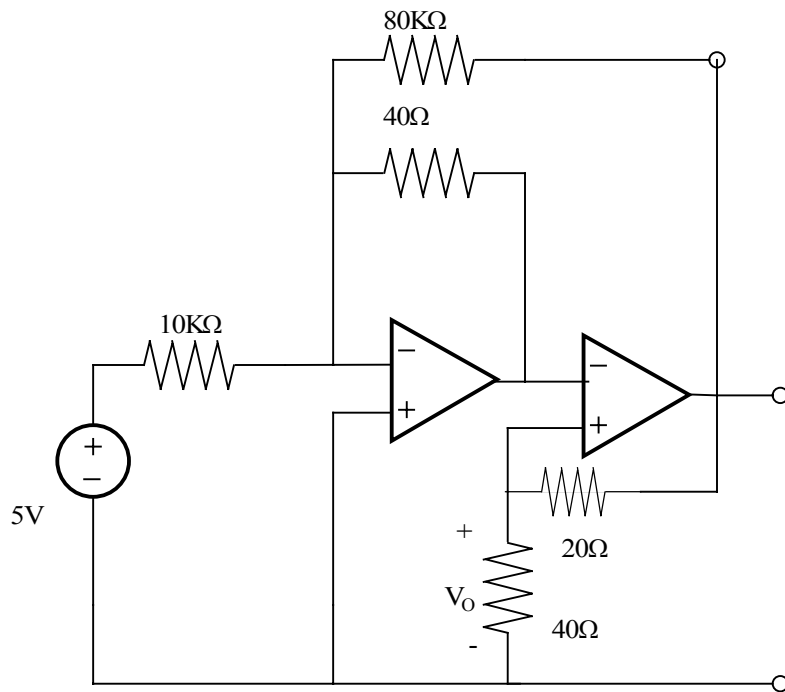

Suggested Solution

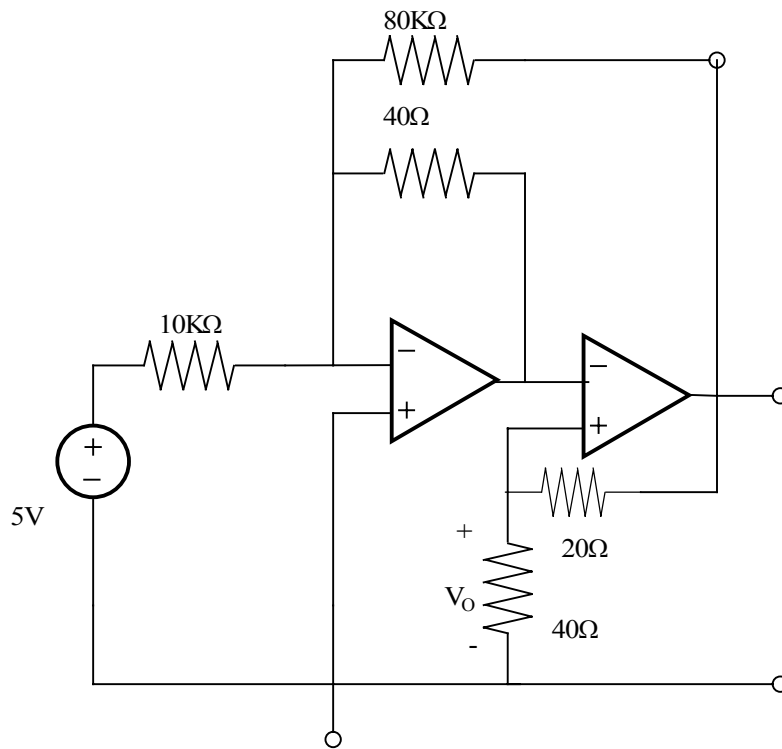

KCL at the inverting input

$$\frac{9-6}{10K} + \frac{10-6}{20K} + \frac{-12-6}{30K} = \frac{6}{40K} + \frac{6-V_0}{100K}$$

$$V_0 = 31V$$

$$V_x = 0, V_y = V_0$$

Node - Z

$$V_z = \left(\frac{40K + 20}{40K}\right)V_0 = \frac{3}{2}V_0$$

Node - X

$$\frac{5}{10K} + \frac{3V_0}{160K} + \frac{V_0}{40K} = 0$$

$$V_0 = -11.4V$$

$$V_0 = -11.4V$$

Problem 3FE-1

Find V_o in the circuit shown.

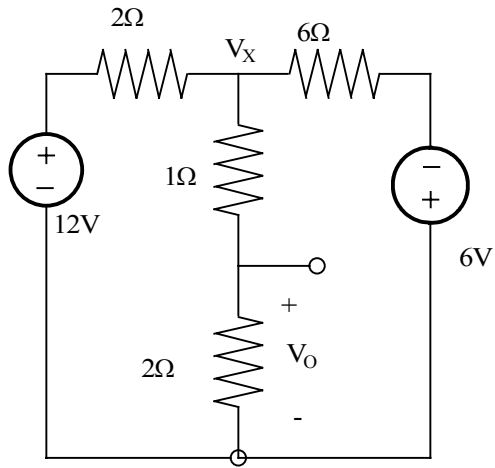

Suggested Solution

KCL at node V_x

$$\frac{V_x - 12}{2} + \frac{V_x}{3} + \frac{V_x + 6}{6} = 0$$

$$V_x = 5V$$

$$V_o = V_x \left(\frac{2}{2+1} \right) = \frac{10}{3} V$$

$$V_o = V_x \left(\frac{2}{2+1} \right) = \frac{10}{3} V$$

Problem 3FE-2

Determine the power dissipated in the 6-ohm resistor in the network shown.

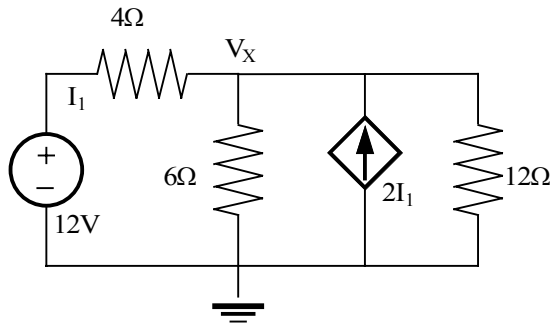

Suggested Solution

KCL at node V_x

$$\frac{V_x - 12}{4} + \frac{V_x}{6} - 2\left(\frac{12 - V_x}{4}\right) + \frac{V_x}{12} = 0$$

$$V_x = 9V$$

$$P_{6\Omega} = \frac{V^2}{R} = \frac{9^2}{6} = 13.5W$$

$$P_{6\Omega} = 13.5W$$

Problem 3FE-3

Find the current I_x in the 4-ohm resistor in the circuit shown.

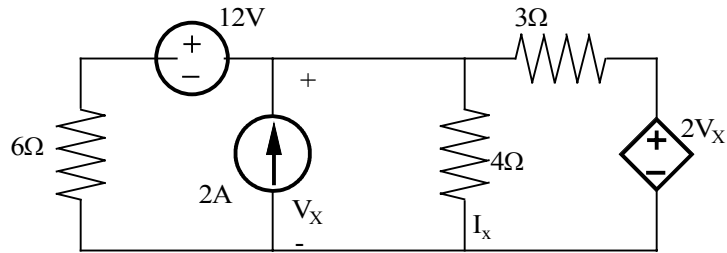

Suggested Solution

KCL at

$$\frac{V_x - 12}{6} - 2 + \frac{V_x}{4} + \frac{V_x - 2V_x}{3} = 0$$

$$V_x = 48V$$

$$I_x = 12A$$

$$I_x = 12A$$

Problem 3FE-4

Determine the voltage V_o in the circuit shown.

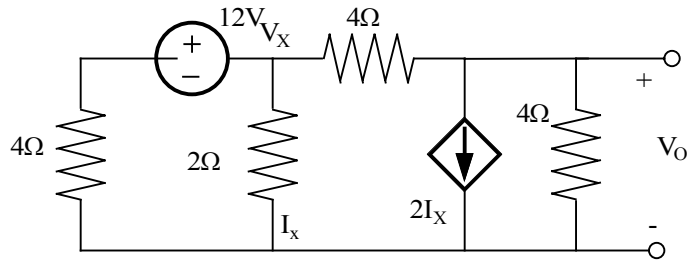

Suggested Solution

KCL at Non Reference nodes

$$\frac{V_x - 12}{4} + \frac{V_x}{2} + \frac{V_x - V_o}{4} = 0$$

$$\frac{V_o - V_x}{4} + 2I_x + \frac{V_o}{4} = 0$$

$$I_x = \frac{V_x}{2}$$

$$V_x - \frac{1}{4}V_o = 3$$

$$\frac{3}{4}V_x + \frac{1}{2}V_o = 0$$

$$\begin{bmatrix} V_x \\ V_o \end{bmatrix} = \begin{bmatrix} 1 & -1 \\ 3 & 1 \end{bmatrix}^{-1} \begin{bmatrix} 3 \\ 0 \end{bmatrix}$$

$$V_o = -3.27V$$

$$V_o = -3.27V$$

Problem 3FE-5

Given the summing amplifier shown, select the values of R_2 that will produce an output voltage of -3v .

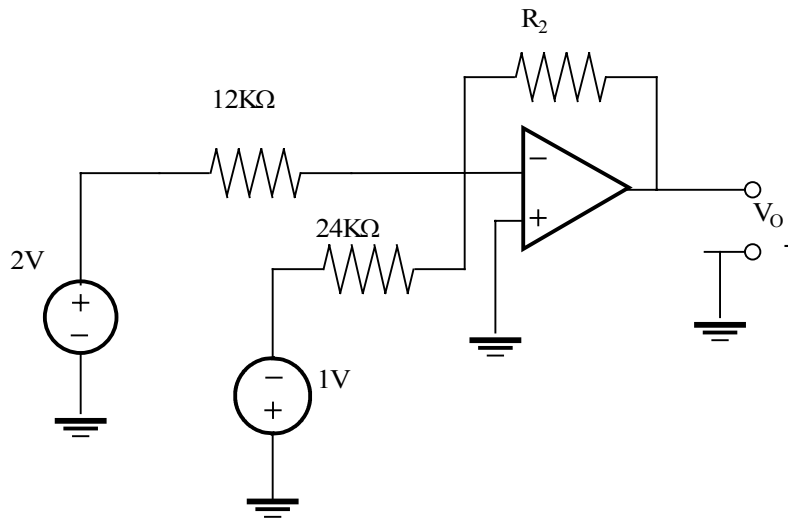

Suggested Solution

$$V_0 = \frac{-R_2}{12K} (2) - \frac{R_2}{24K} (-1)$$

$$-3 = \frac{-2R_2}{12K} + \frac{R_2}{24K} = 0$$

$$R_2 = 24K\Omega$$

$$R_2 = 24K\Omega$$

Problem 3FE-6

Determine the output voltage V_o of the summing op-amp circuit shown.

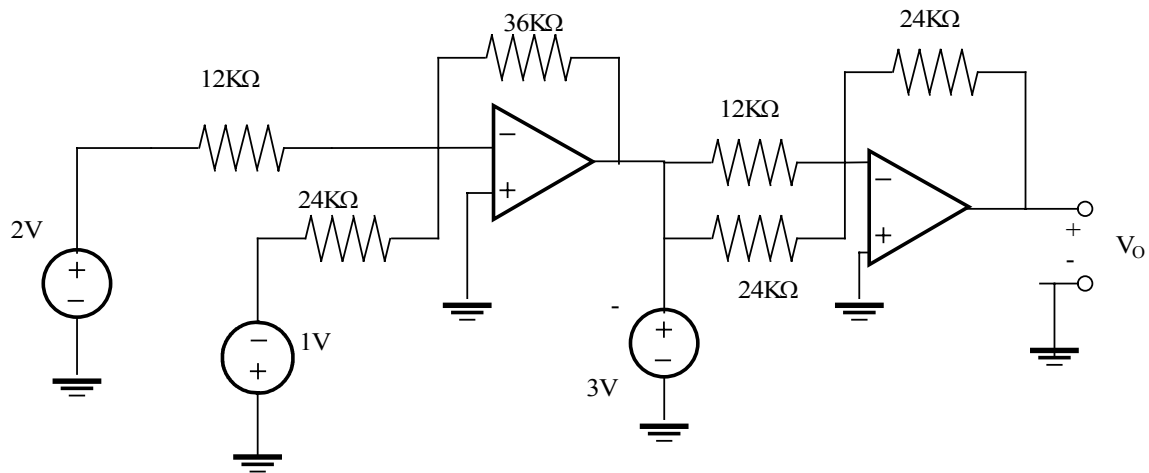

Suggested Solution

At the output of 1st op-amp

$$V_1 = \frac{-36(2)}{12} - \frac{36(-1)}{24} = \frac{-9}{2}V$$

$$V_o = -\left(\frac{24}{12}\right)\left(-\frac{9}{2}\right) - \left(\frac{24}{24}\right)(-3) = 6V$$

$$V_o = 6V$$

$$V_o = 6V$$

Problem 4.1

Find I_o in the circuit shown using linearity and the assumption that $I_o = 1\text{mA}$.

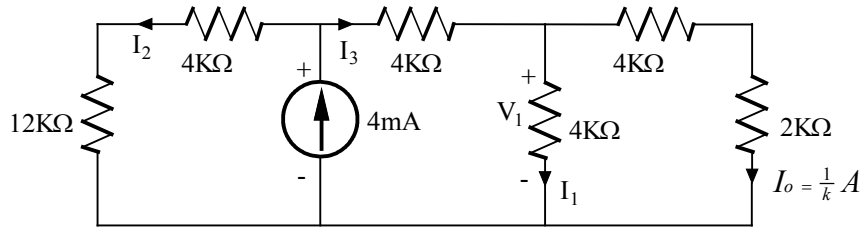

Suggested Solution

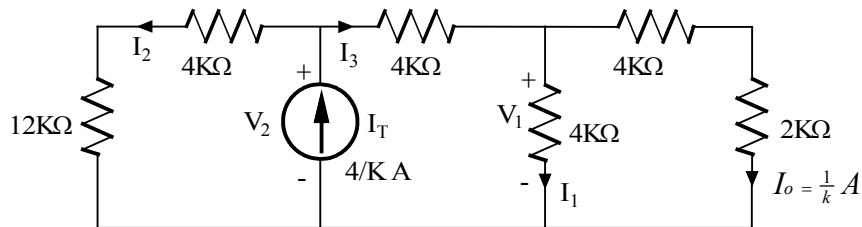

If $I_o = \frac{1}{k} A$ Then $V_2 = \frac{1}{k}(4K + 2K) = 6V$, $I_1 = \frac{6}{4k} = \frac{3}{2} mA$

Then $I_2 = I_1 + I_o = \frac{5}{2} mA$ and $V_2 = V_1 + 4KI_2 = 16V$

Then $I_3 = \frac{V_2}{4K + 12K} = 1mA \therefore I_T = I_2 + I_3 = \frac{7}{2} mA$

So $\frac{7/2 mA}{1mA} = \frac{4mA}{x} \therefore x = \boxed{I_o = \frac{8}{7} mA}$

Problem 4.2

Find I_o in the network shown using linearity and the assumption that $I_o = 1\text{mA}$.

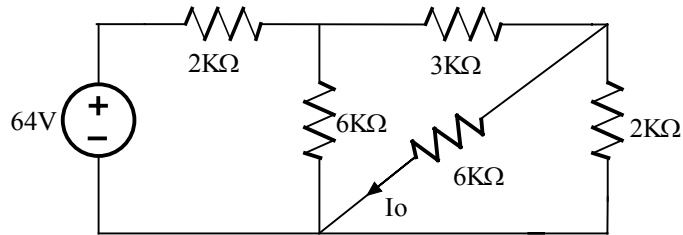

Suggested Solution

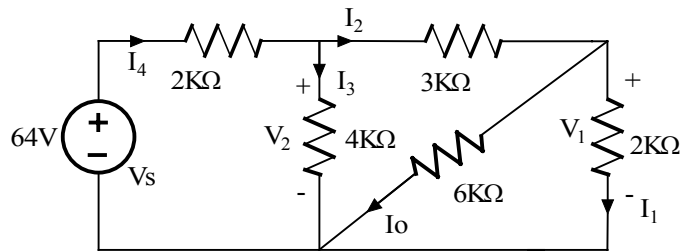

If $I_o = 1\text{mA}$, $V_1 = 6\text{V}$. $I_1 = \frac{6}{2\text{K}} = 3\text{mA}$. $I_2 = I_o + I_1 = 4\text{mA}$

$V_2 = V_1 + 3\text{K}I_2 = 18\text{V}$, $I_3 = \frac{V_2}{6\text{K}} = 3\text{mA}$ Then $I_4 = I_2 + I_3 = 7\text{mA}$

$V_s = V_2 + 2\text{K}I_4 = 32\text{V} \therefore \frac{32}{1\text{mA}} = \frac{64}{x} \therefore x = \boxed{I_o = 2\text{mA}}$

Problem 4.3

Find V_o in the network shown using linearity and the assumption that $V_o=1\text{mV}$

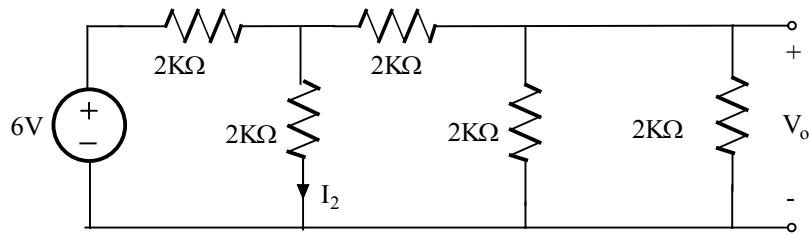

Suggested Solution

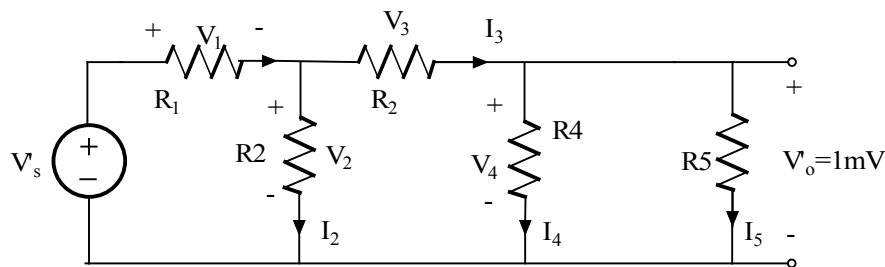

All $R = 2\text{K}\Omega$, $V_s = 6\text{V}$

$$I_5 = \frac{V'_o}{R_5} = \frac{1}{2} \mu\text{A} \quad I_4 = \frac{V'_o}{R_4} = \frac{1}{2} \mu\text{A} \quad I_3 = I_4 + I_5 = 1 \mu\text{A}$$

$$V_3 = I_3 R_3 = 2\text{mV} \quad V_2 = V_3 + V'_o = 3\text{mV} \quad I_2 = \frac{V_2}{R_2} = 1.5 \mu\text{A}$$

$$I_1 = I_2 + I_3 = 2.5 \mu\text{A} \quad V_1 = I_1 R_1 = 5\text{mV} \quad V'_s = V_1 + V_2 = 8\text{mV}$$

$$\frac{V_o}{V_s} = \frac{V'_s}{V_s} \Rightarrow V_o = \left(\frac{6}{8\text{m}}\right)(1\text{m}) = 0.75\text{V}$$

$$\boxed{V_o = 0.75\text{V}}$$

Problem 4.4

Find V_o in the circuit shown using linearity and the assumption that $V_o=1V$

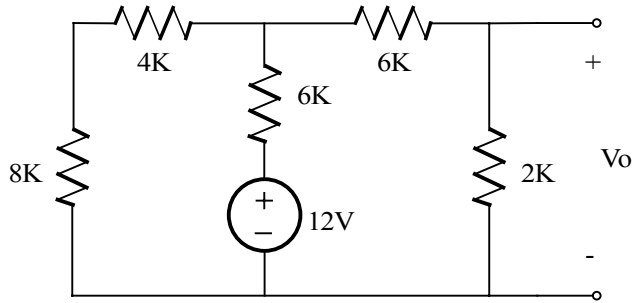
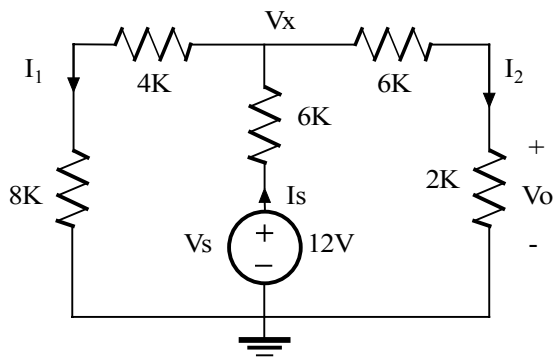

Figure P4.4

Suggested Solution



Assume $V_o = 1V$

$$I_2 = \frac{V_o}{2K} = \frac{1}{2} mA \Rightarrow V_x = I_2(8K) = 4V$$

$$I_1 = \frac{V_x}{12K} = 0.333mA$$

$$I_s = I_1 + I_2 = 0.8333mA$$

$$V_s = I_s(6K) + V_x = 9V$$

$$\frac{9V}{1V} = \frac{12V}{V_o} \Rightarrow \boxed{V_o = 1.33V}$$

Problem 4.5

In the network shown find I_o using superposition

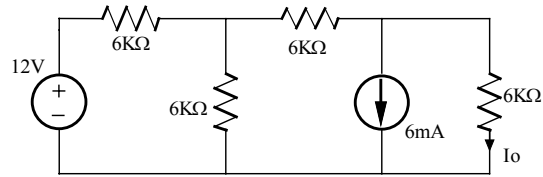

Suggested Solution

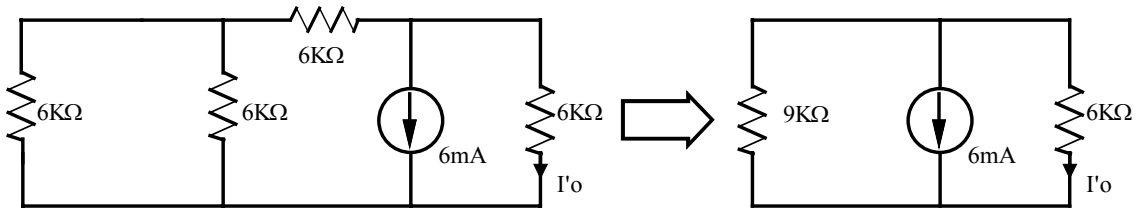

Zero the indep. voltage source

$$I'_o = -0.006\left(\frac{9K}{9K+6K}\right) = -\frac{18}{5} mA$$

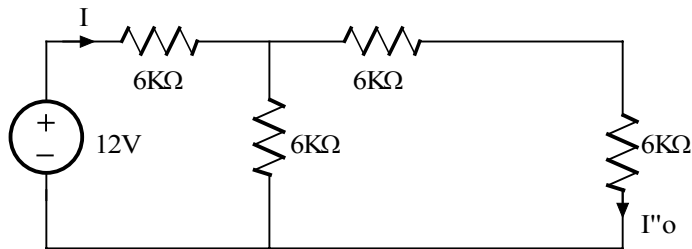

Zero the indep. current souce

$$I = \frac{12}{6K+6K\parallel(6K+6K)} = \frac{6}{5} mA$$

$$I''_o = I\left(\frac{6K}{6K+12K}\right) = \frac{2}{5} mA$$

$$I_o = I'_o + I''_o = \left(-\frac{18}{5} + \frac{2}{5}\right) mA = -\frac{16}{5} mA$$

Problem 4.6

Find I_o in the circuit shown using superposition

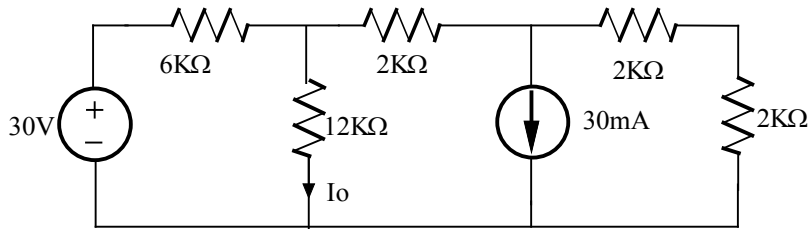

Suggested Solution

Zero the indep. current source

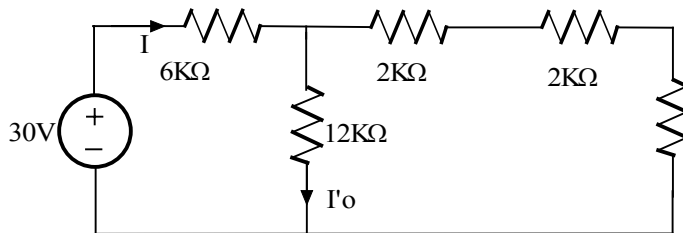

$$I = \frac{30}{6K + 12K \parallel 6K} = 3mA, \quad I'o = I \frac{6K}{18K} = 1mA$$

Zero the indep. voltage source

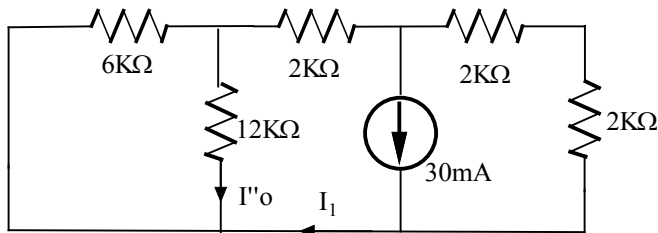

$$I_1 = 0.03 \left(\frac{4K}{4K + 2K + 6K \parallel 12K} \right) = 12mA$$

$$I''o = -0.012 \left(\frac{6K}{18K} \right) = -4mA$$

$$\boxed{I_o = I'o + I''o = 3mA}$$

Problem 4.7

In the network shown find V_o using superposition

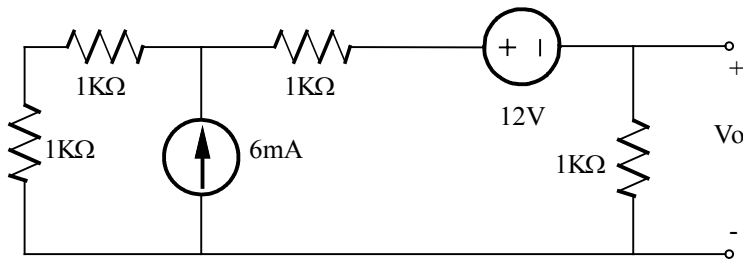

Suggested Solution

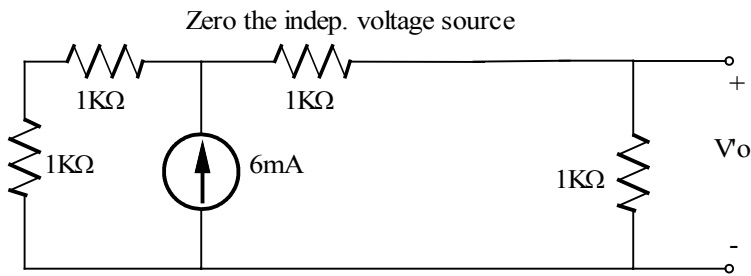

$$V'o = 0.006 \left(\frac{2K}{2K+2K} \right) (1k) = 3V$$

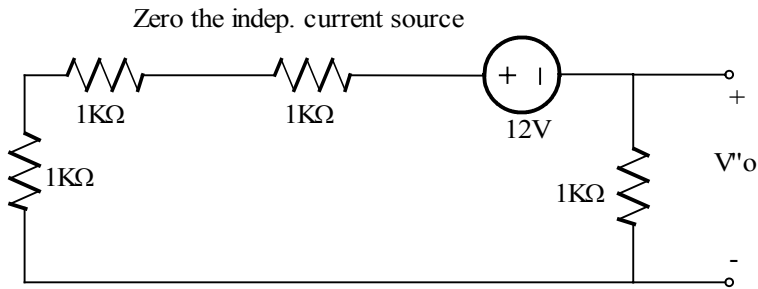

$$V''o = \frac{-12}{4K} (1K) = -3V$$

$$\boxed{V_o = V'o + V''o = 0V}$$

Problem 4.8

Find V_o in the network shown using superposition

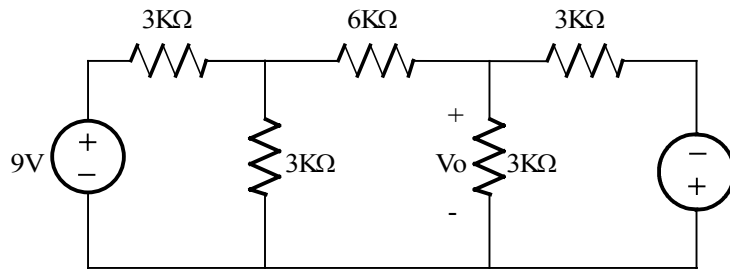

Suggested Solution

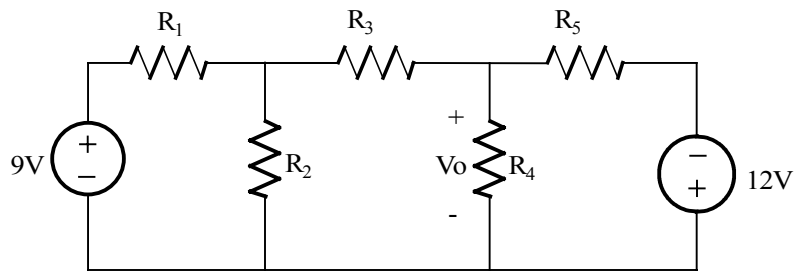

$R_3 = 6K\Omega$ All other $R = 3K\Omega$

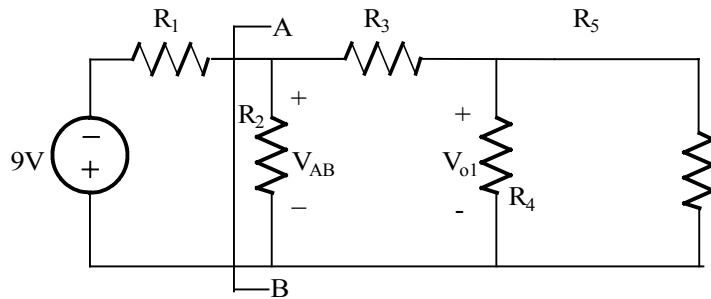

$$R_{AB} = R_2 \parallel [R_3 + (R_4 \parallel R_5)] = 2.14K\Omega$$

$$V_{AB} = 9 \left(\frac{R_{AB}}{R_{AB} + R_1} \right) = 3.75V$$

$$V_{o1} = V_{AB} \left(\frac{R_4 \parallel R_5}{(R_4 \parallel R_5) + R_3} \right) = 0.75V$$

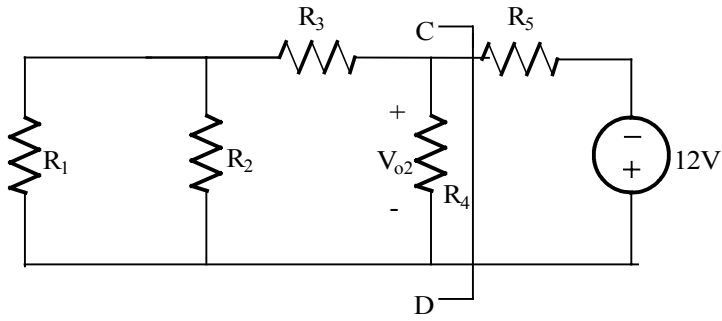

$$R_{CD} = R_4 \parallel [R_3 + (R_1 \parallel R_2)] = 2.14K\Omega$$

$$V_{02} = -12 \left(\frac{R_{CD}}{R_{CD} + R_5} \right) = -5V$$

$$\boxed{V_O = V_{01} + V_{02} = -4.25V}$$

Problem 4.9

Find I_o in the network shown using superposition.

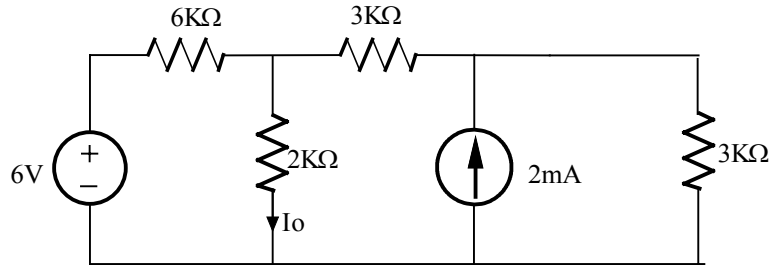

Suggested Solution

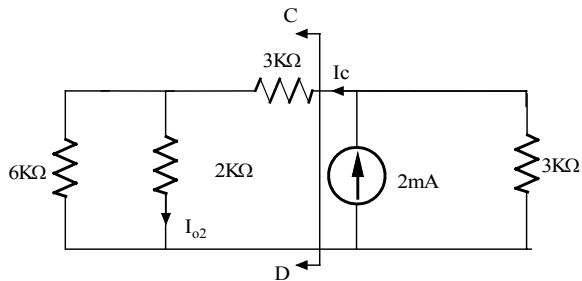

$$R_{CD} = 3K + (6K \parallel 2K) = 4.5K\Omega$$

$$I_c = 2m \left(\frac{3K}{3K + R_{CD}} \right) = 0.8mA$$

$$I_{o2} = I_c \left(\frac{6K}{6K + 2K} \right) = 0.6mA$$

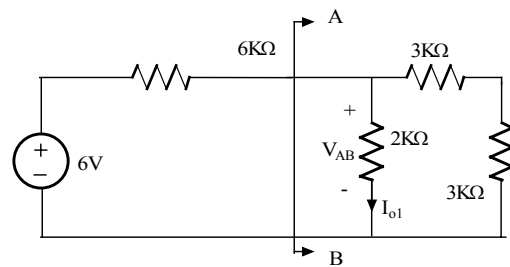

$$R_{AB} = 2K \parallel (3K + 3K) = 1.5K\Omega$$

$$V_{AB} = 6 \left(\frac{R_{AB}}{R_{AB} + 6K} \right) = 1.2V$$

$$I_{o1} = V_{AB} / 2K = 0.6mA$$

$$\boxed{I_o = I_{o1} + I_{o2} = 1.2mA}$$

Problem 4.10

Find I_0 in the network shown using superposition

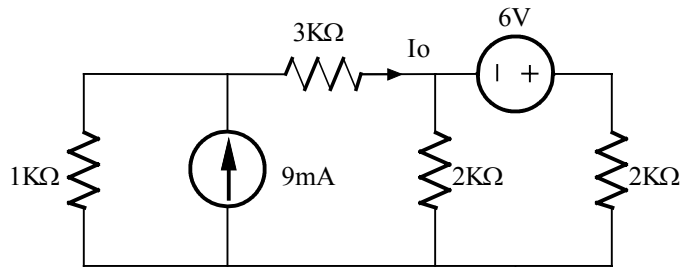

Suggested Solution

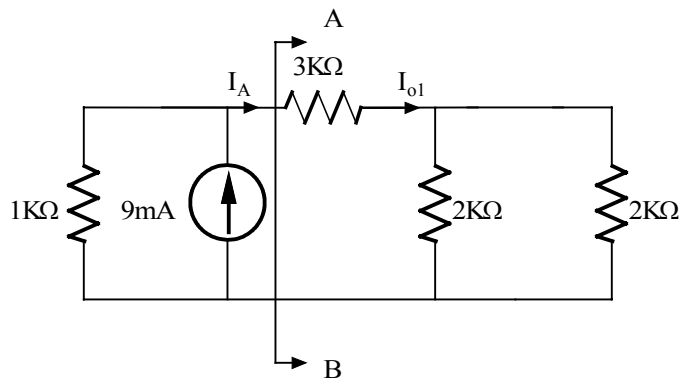

$$R_{AB} = 3K + (2K \parallel 2K) = 4K\Omega$$

$$I_A = I_{01} = 9m \left(\frac{1K}{1K + R_{AB}} \right) = 1.8mA$$

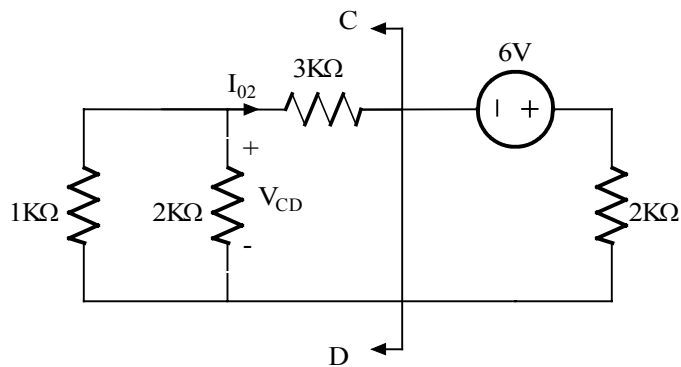

$$R_{CD} = (1K + 3K) \parallel 2K = 1.33K\Omega$$

$$V_{CD} = -6 \left[\frac{R_{CD}}{R_{CD} + 2K} \right] = -2.4V$$

$$I_{02} = -\frac{V_{CD}}{1K + 3K} = 0.6mA$$

$$I_0 = I_{01} + I_{02} = 2.4mA, \quad \boxed{I_0 = 2.4mA}$$

Problem 4.11

Find I_o in the network shown using superposition.

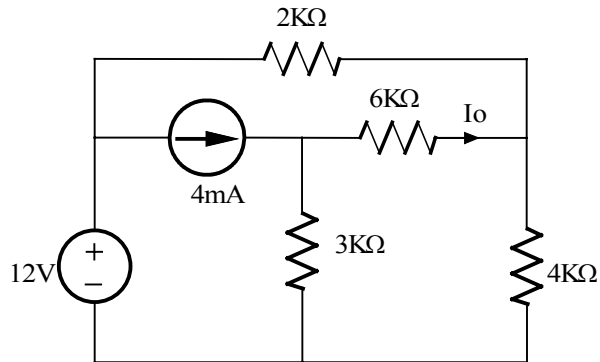

Suggested Solution

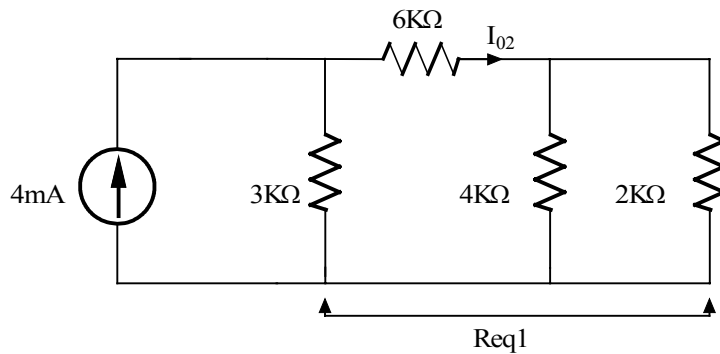

$$R_{eq1} = 6K + (2K \parallel 4K) = 7.33K$$

$$I_{o2} = 4m \left[\frac{3K}{3K + R_{eq1}} \right] = 1.16mA$$

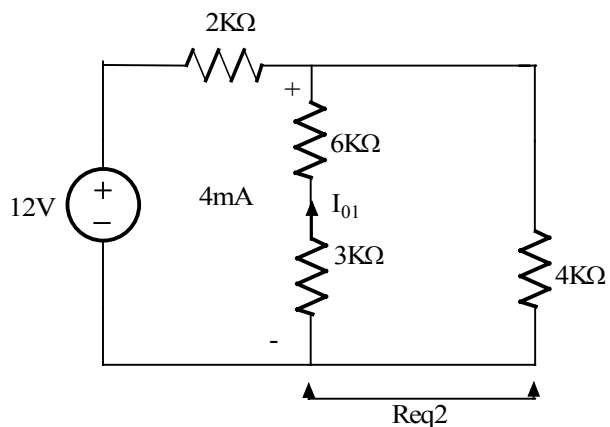

$$R_{eq2} = 9K \parallel 4K = 2.77k\Omega, \quad V_x = 12 \left[\frac{R_{eq2}}{R_{eq2} + 2K} \right] = 6.97V$$

$$I_{o1} = -\frac{V_x}{9K} = -0.77mA$$

$$I_o = I_{o1} + I_{o2} = 0.39mA$$

Problem 4.12

Find I_o in the network shown using superposition

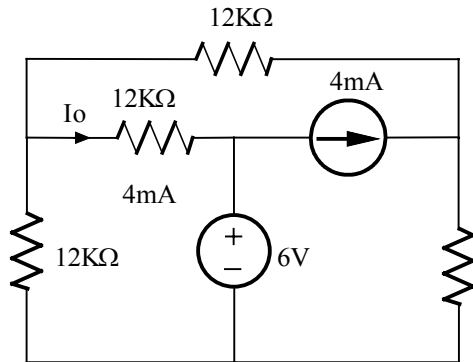

Suggested Solution

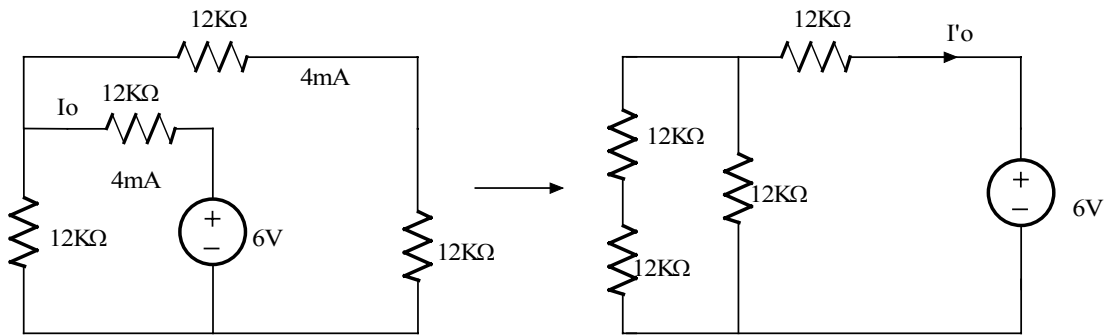

$$I'o = \frac{-6}{12K+12K \parallel (12K+12K)} = -\frac{3}{10} \text{ mA}$$

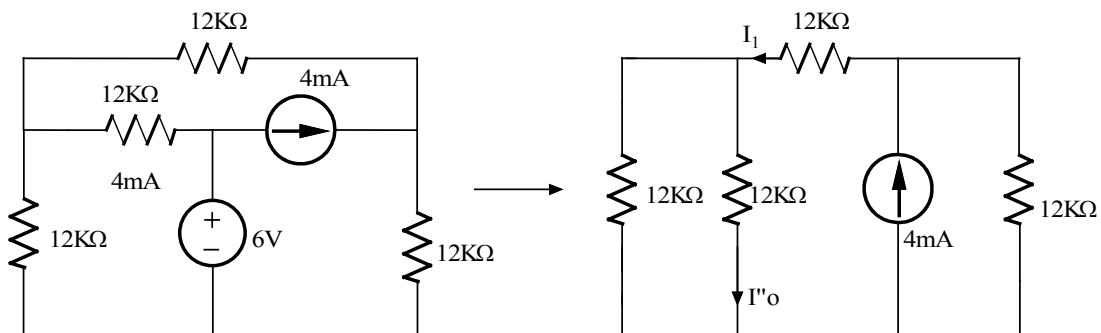

$$I_1 = 4m \left(\frac{12K}{12K+12K \parallel 12K} \right) = 1.6 \text{ mA}$$

$$I''o = \frac{1}{2} I_1 = 0.8 \text{ mA}$$

$$I_o = I'o + I''o = \frac{-0.003}{10} + \frac{0.008}{10} = \frac{1}{2} \text{ mA}$$

Problem 4.13

Find I_o in the circuit shown using superposition

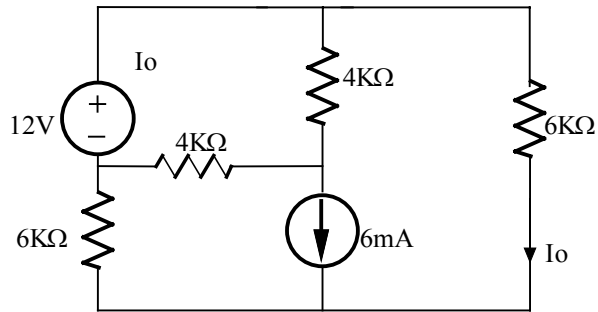

Suggested Solution

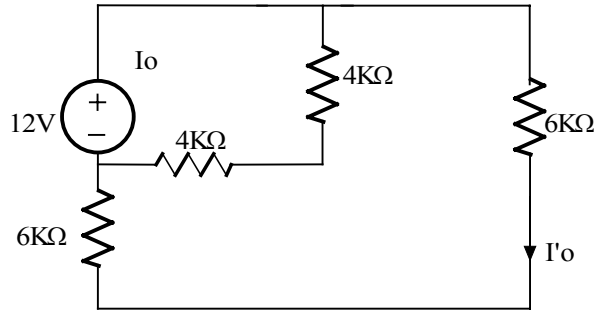

$$I'o = \frac{0.012}{12} = 1mA$$

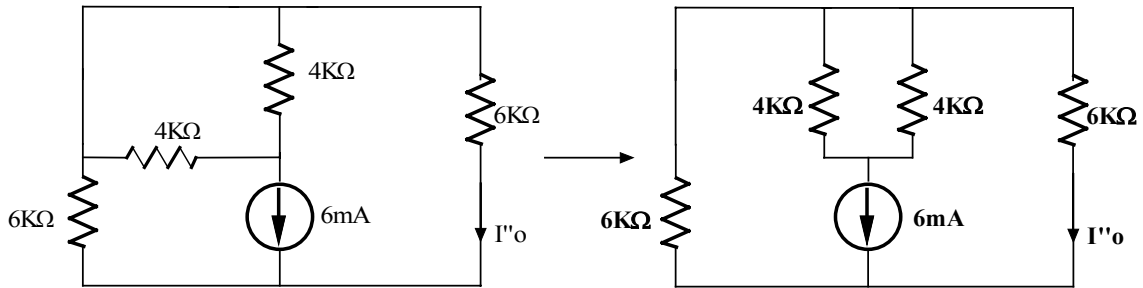

Current splits equally: $I''o = -3mA$

$$I_o = I'o + I''o = -2mA$$

Problem 4.14

Use superposition to find I_o in the circuit shown

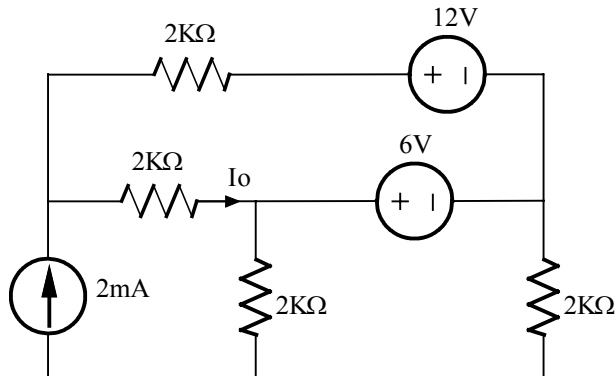

Suggested Solution

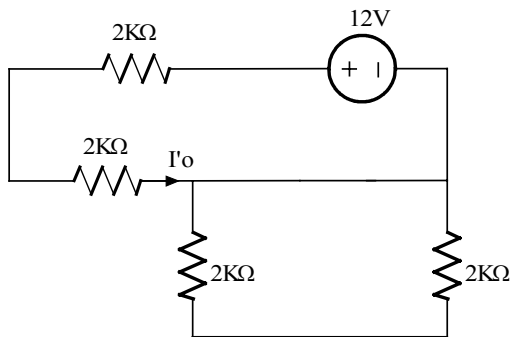

$$I'o = 12/4K = 3\text{mA}$$

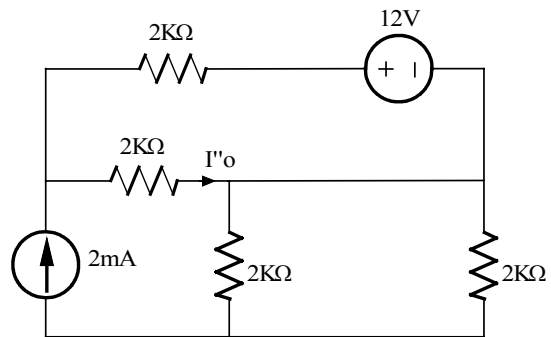

Current Splits equally
 $I''o = 1\text{mA}$

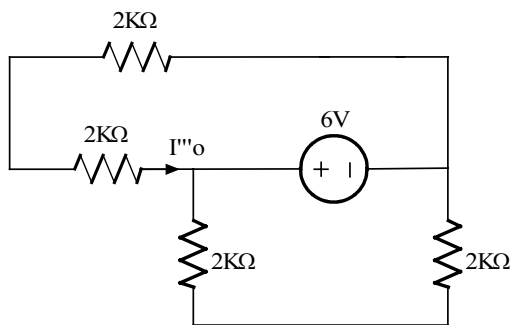

$$I'''o = -6/4K = -3/2\text{mA}$$

Then $I_o = I'o + I''o + I'''o = 3\text{mA} + 1\text{mA} - 3/2\text{mA} = 5/2\text{mA}$

Problem 4.15

Find I_o in the network shown using superposition

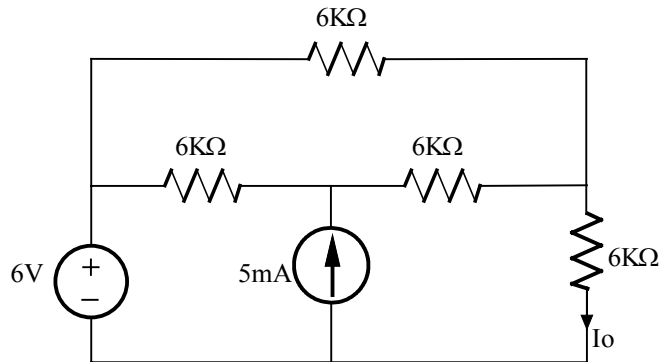

Suggested Solution

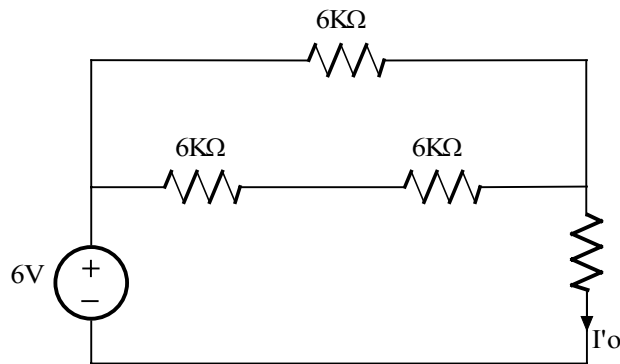

$$I'o = \frac{-6}{6K+6K \parallel (6K+6K)} = \frac{-6}{10K} \text{ A}$$

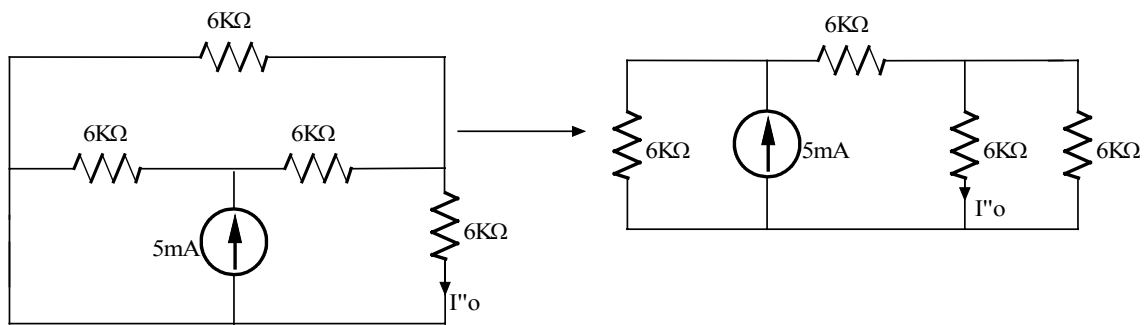

$$I''o = 5m \left(\frac{6K}{6K+6K+6K \parallel 6K} \right) \left(\frac{1}{2} \right) = 1mA$$

$$I_o = I'o + I''o = 1mA + \frac{3}{5}mA = \frac{2}{5}mA$$

Problem 4.16

Find I_o in the network shown using superposition.

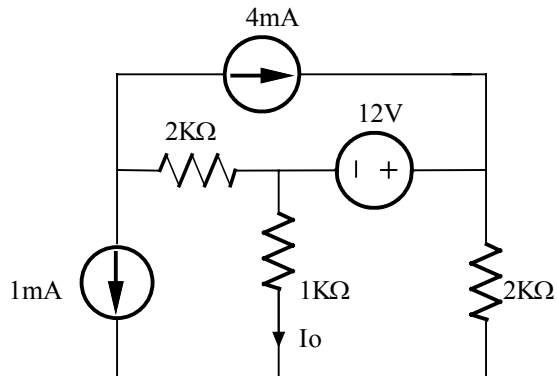

Suggested Solution

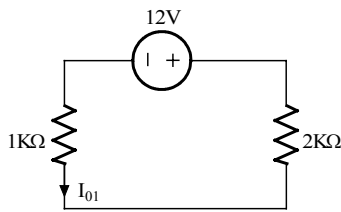

I_o due to 12V source

$$I_{o1} = -12 / (1K + 2K) = -4mA$$

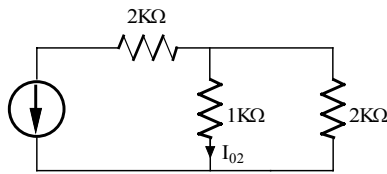

I_o due to 2mA source

$$I_{o2} = 2m [2K / (2K + 3K)] = -1.33mA$$

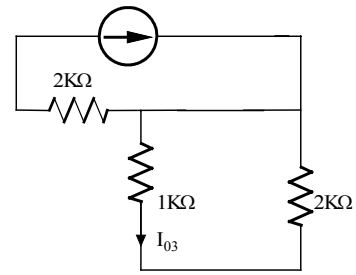

I_o due to 4mA source

$$I_{o3} = 0A$$

$$I_o = I_{o1} + I_{o2} + I_{o3} = -5.33mA$$

Problem 4.17

Find I_o in the network shown using superposition

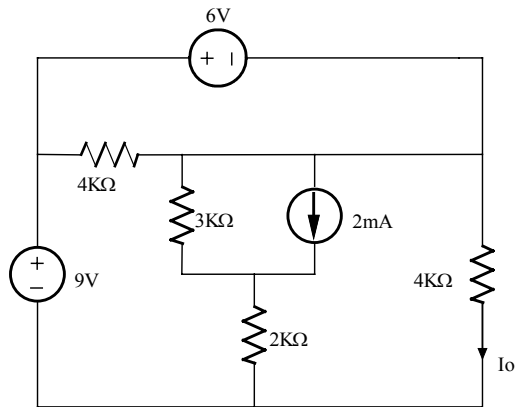

Suggested Solution

I_o due to 9V source

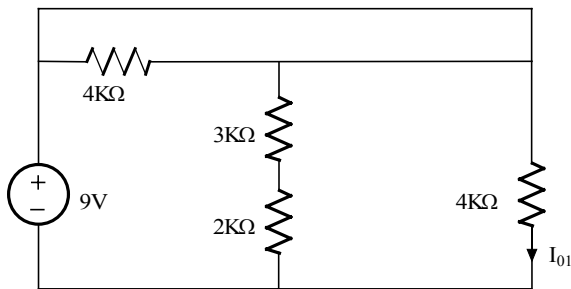

$$I_{o1} = \frac{9}{4K} = 2.25mA$$

I_o due to 6V source (redrawn)

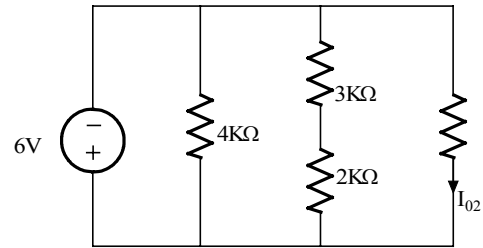

$$I_{o2} = \frac{-6}{4K} = -1.5mA$$

I_o due to 2mA source

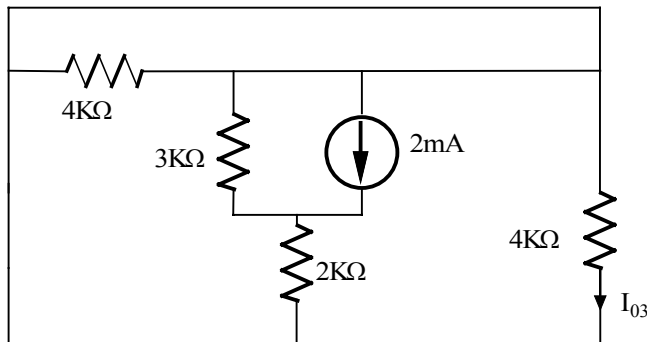

$$(4K)I_{o3} = 0 \rightarrow I_{o3} = 0$$

$$I_o = I_{o1} + I_{o2} + I_{o3}$$

$$\boxed{I_o = 0.75mA}$$

Problem 4.18

Find V_o in the network shown using superposition

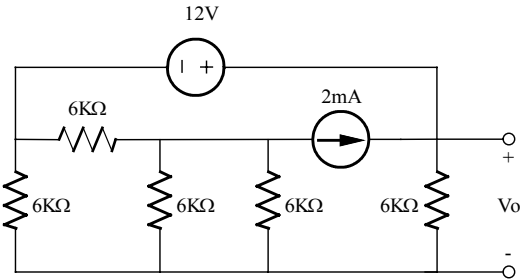

Suggested Solution

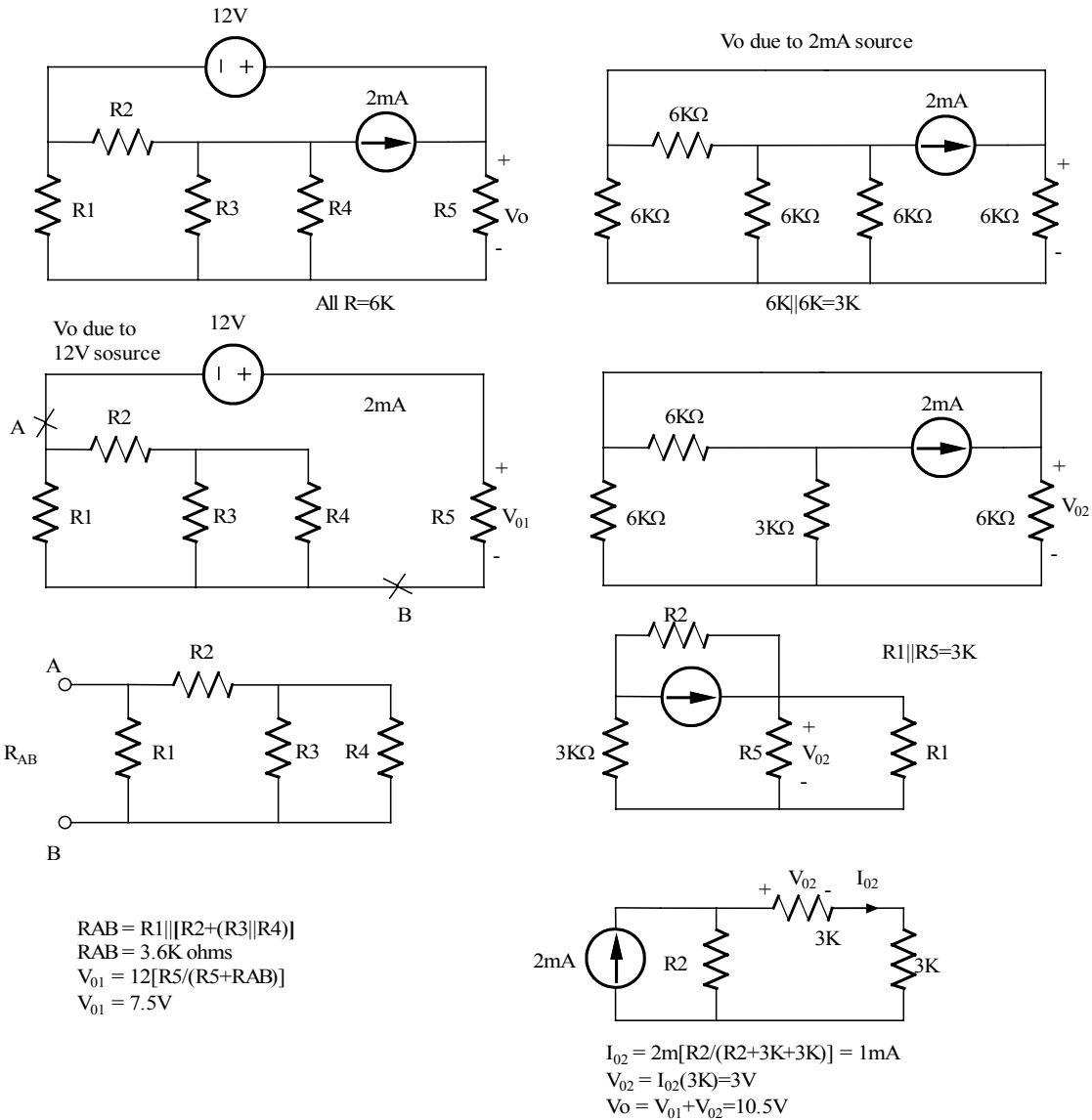

$V_o = 10.5$

Problem 4.19

Use source transformation to find I_o in the circuit shown

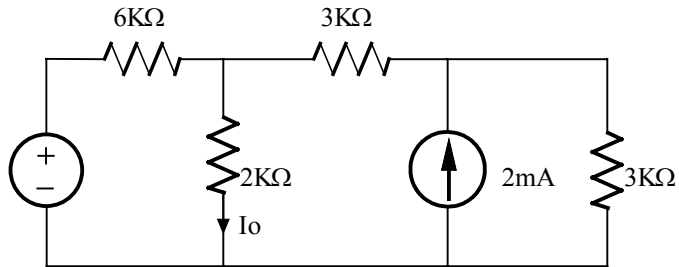

Suggested Solution

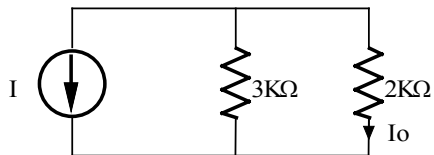
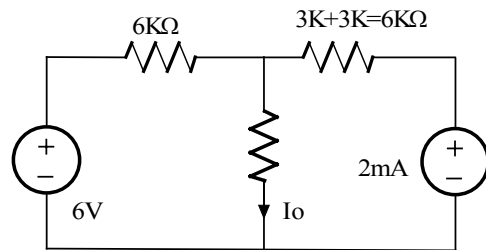
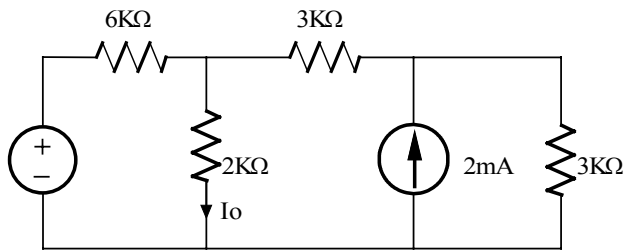

$$I = 6/6K + 6/6K = 2mA$$
$$3K = 6K \parallel 6K$$

$$I_o = I(3K/(2K+3K)) = 1.2mA$$

Problem 4.20

Find V_o in the network shown using source transformation

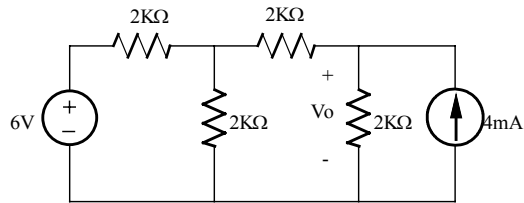

Suggested Solution

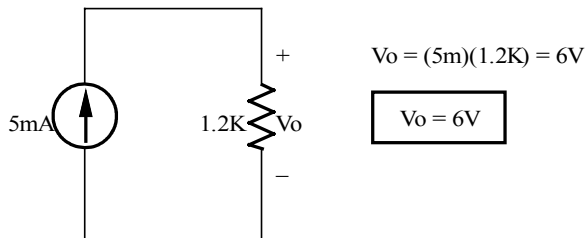
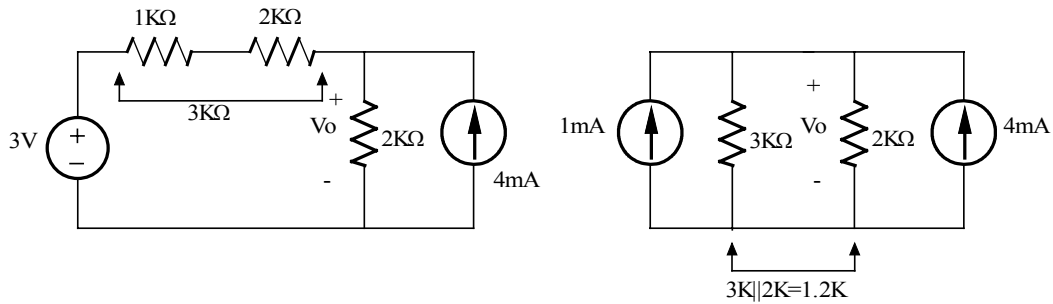
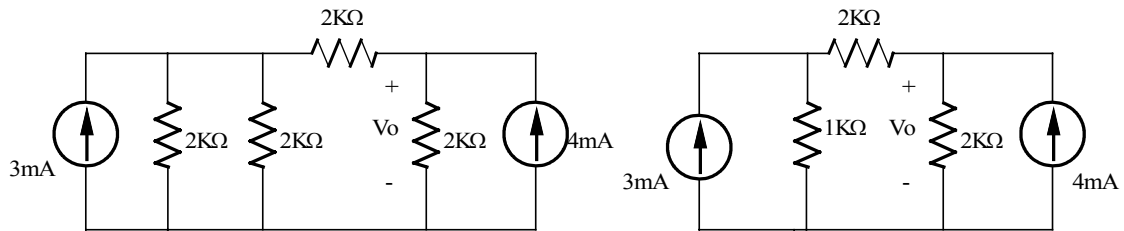

Problem 4.21

Use source transformation to find V_o in the network shown.

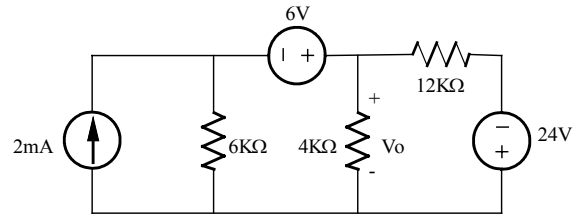

Suggested Solution

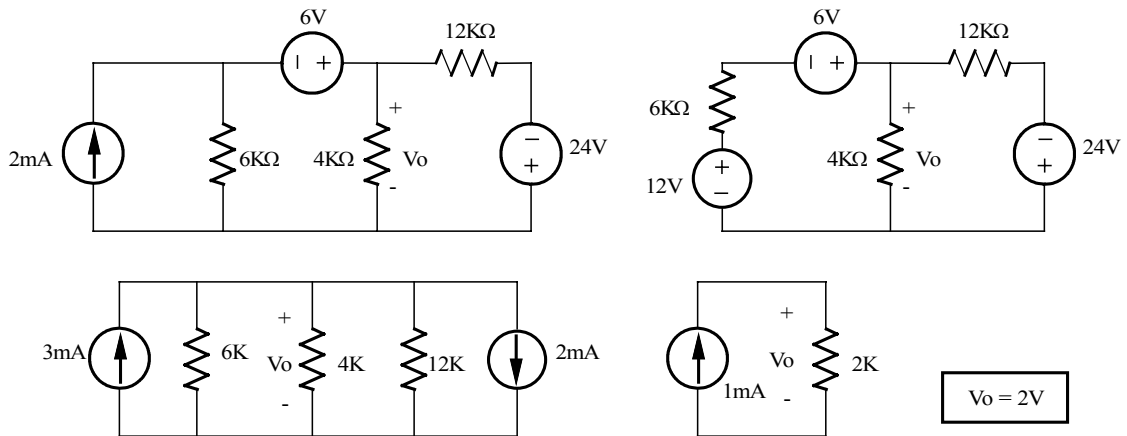

Problem 4.22

Find V_o in the network shown using source transformation

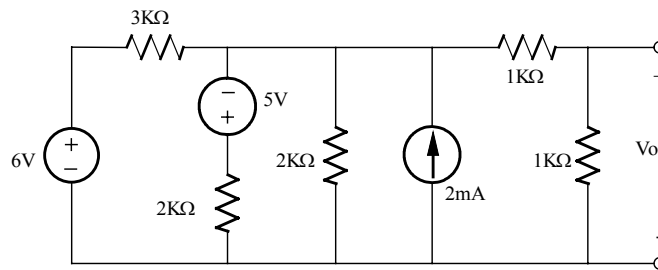

Suggested Solution

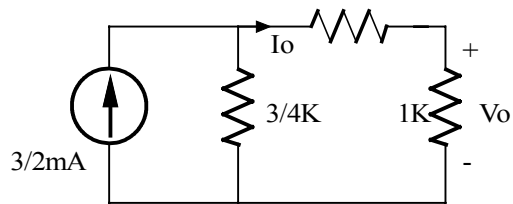
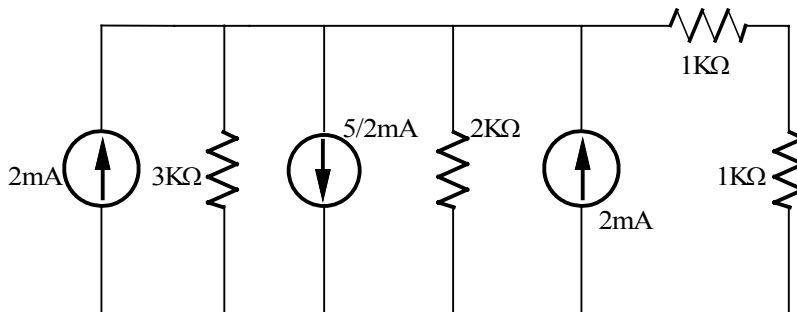

$$I_o = \frac{3}{2K} \left(\frac{3/4K}{3/4K + 2K} \right) = 0.41mA$$

$$V_o = 1K(I_o) = 0.41V$$

Problem 4.23

Find I_o in the circuit shown using source transformation

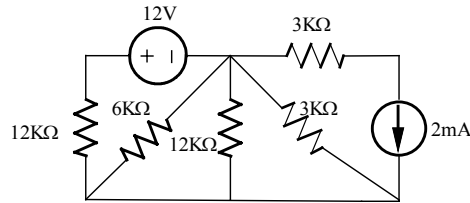

Suggested Solution

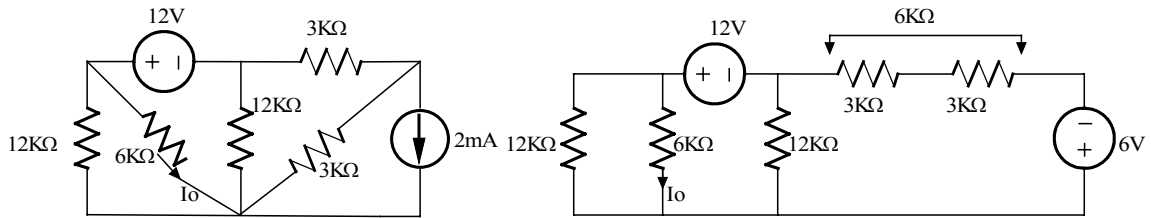
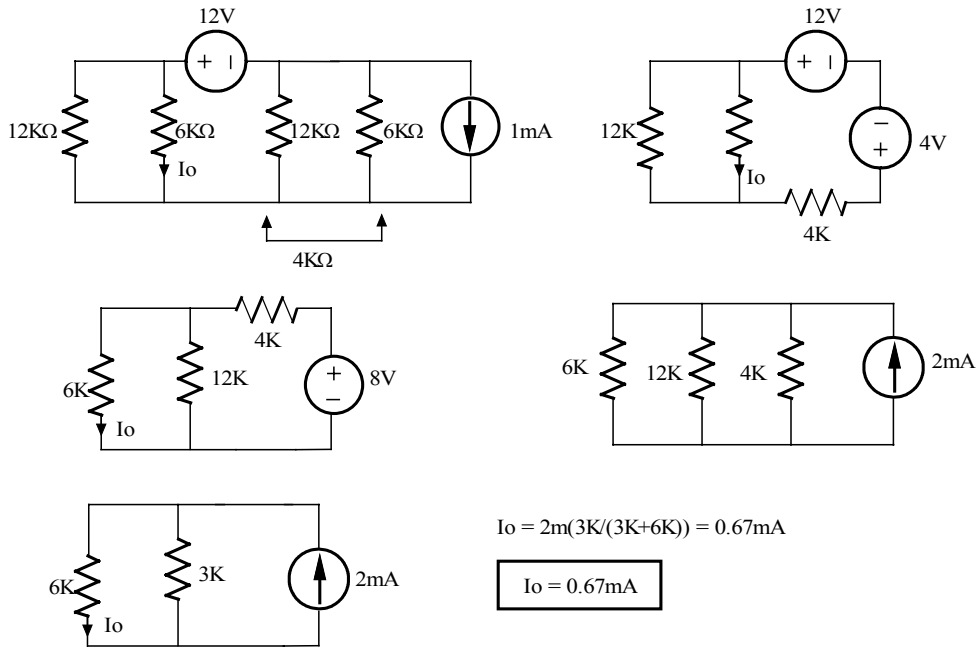

Figure P4.23



$$I_o = 2\text{m}(3\text{K}/(3\text{K}+6\text{K})) = 0.67\text{mA}$$

$I_o = 0.67\text{mA}$

Problem 4.24

Find I_o in the network shown using source transformation.

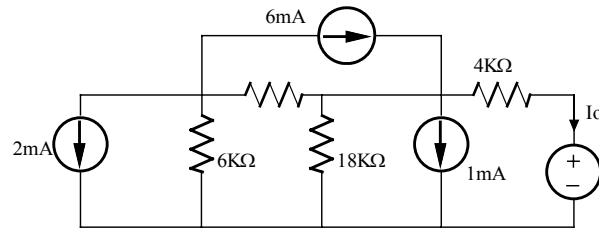

Suggested Solution

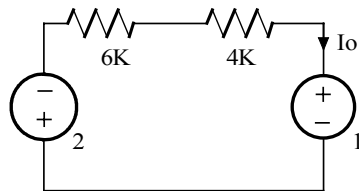
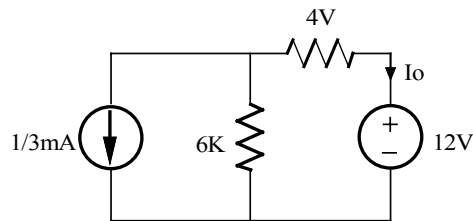
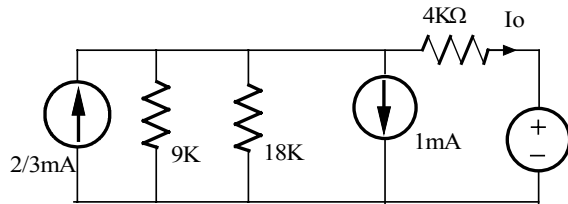
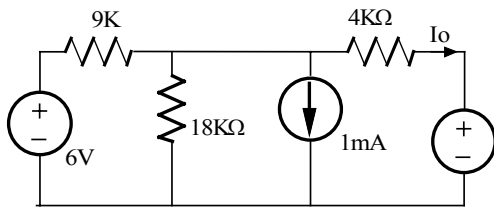
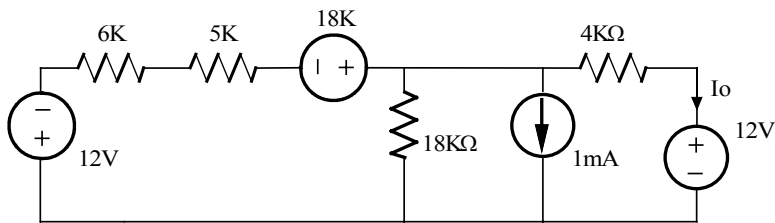

$$I_o = -14/10K = -7/5mA$$

Problem 4.25

Use source transformation to find I_o in the circuit shown.

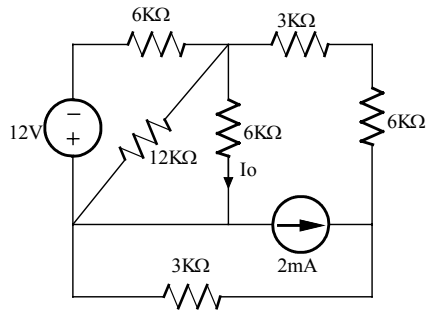

Suggested Solution

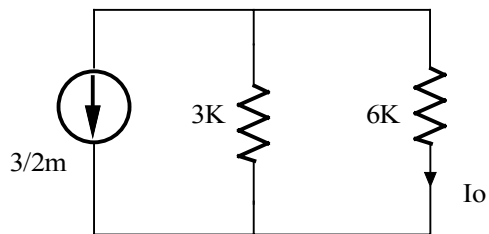
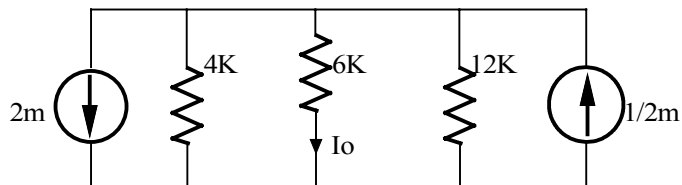
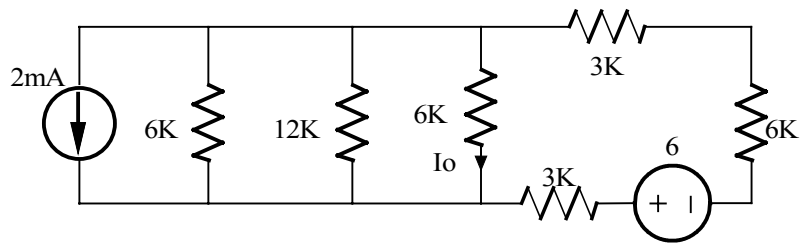

$$I_o = -\frac{3}{2}m(3K/9K) = -1mA$$

Problem 4.26

Find V_o in the network shown using source transformation.

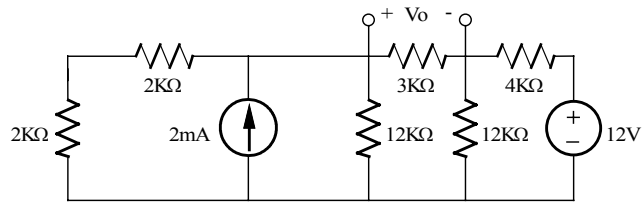

Suggested Solution

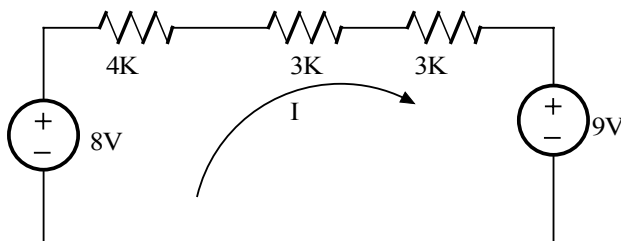
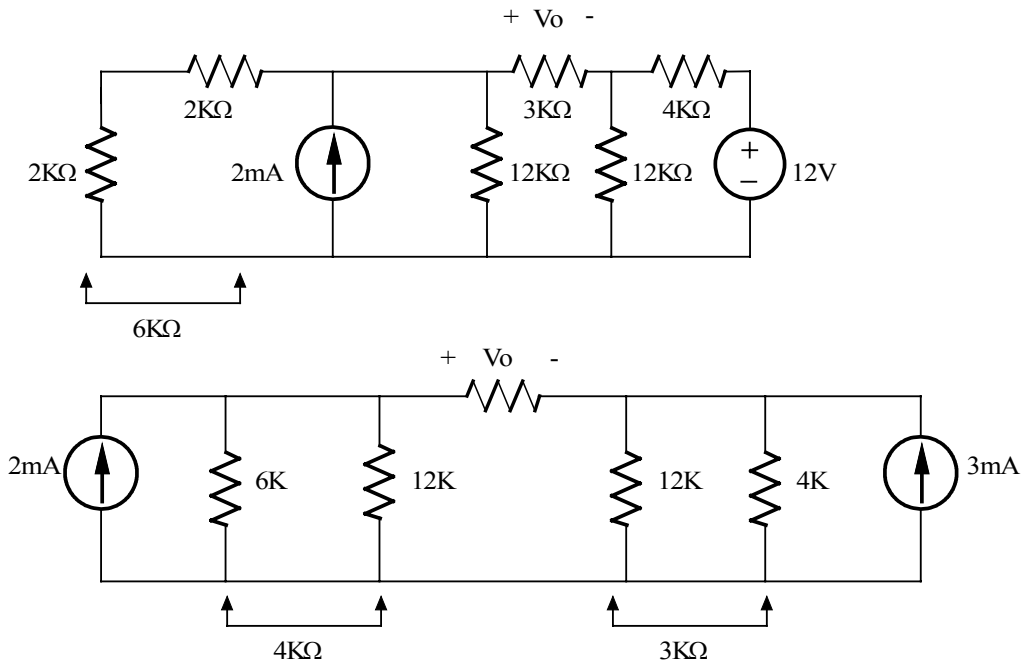

$$\begin{aligned}
 -8 + I(4K + 3K + 3K) + 9 &= 0 \\
 I &= -0.1\text{mA} \\
 V_o = I(3K) &= -0.3\text{V}
 \end{aligned}$$

$V_o = -0.3\text{V}$

Problem 4.27

Find V_o in the circuit shown using source transformation

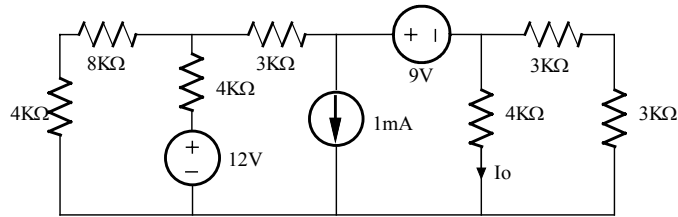

Suggested Solution

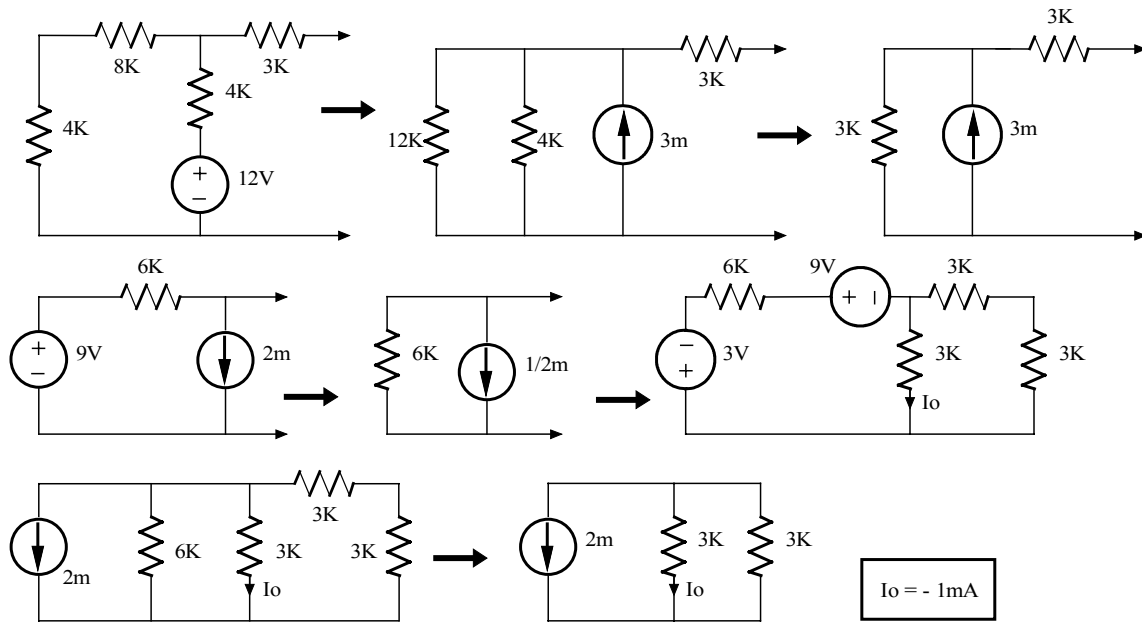

Problem 4.28

Find I_o in the network shown using source transformation.

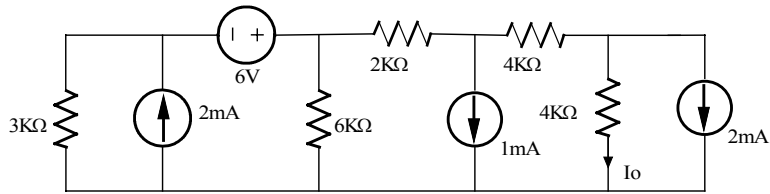

Suggested Solution

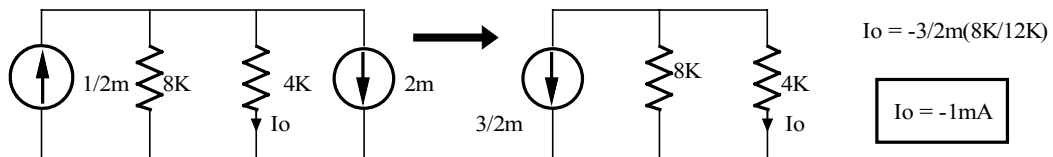
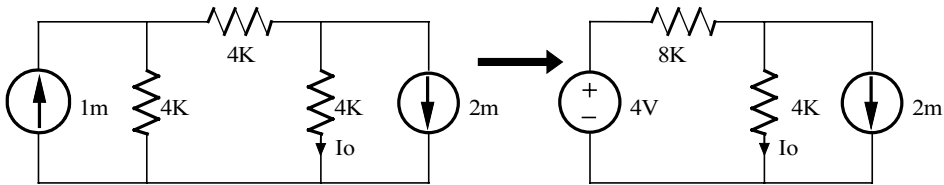
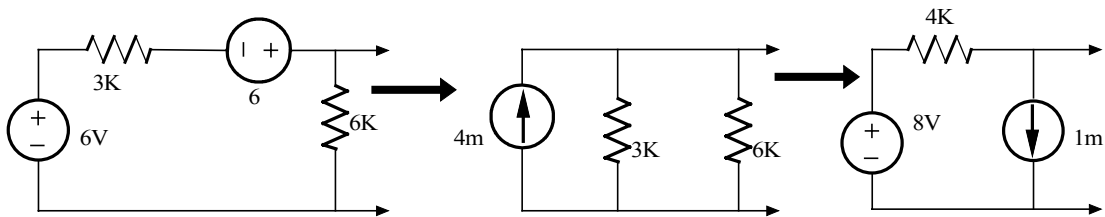

Problem 4.29

Find I_o in the network shown using source transformation.

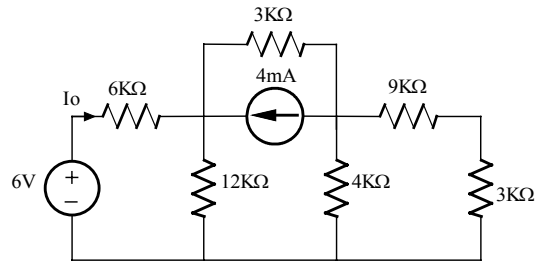

Suggested Solution

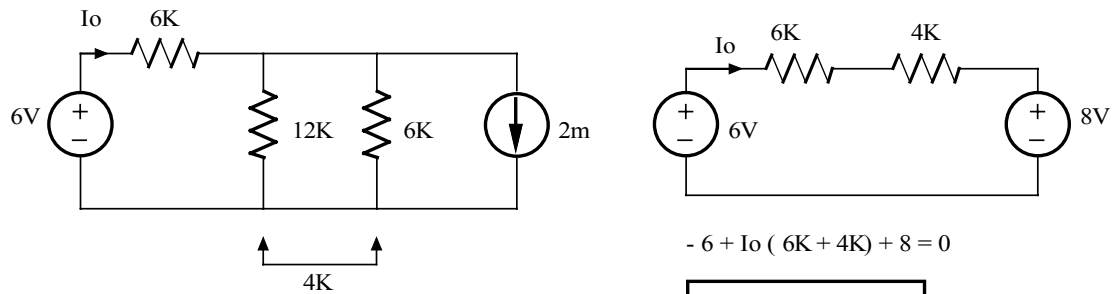
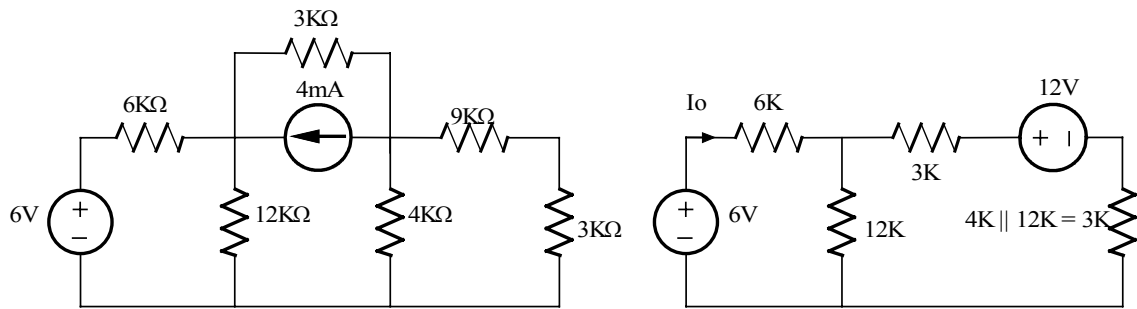

$$-6 + I_o (6K + 4K) + 8 = 0$$

$$I_o = -0.2 \text{ mA}$$

Problem 4.30

Find I_o in the network shown using source transformation.

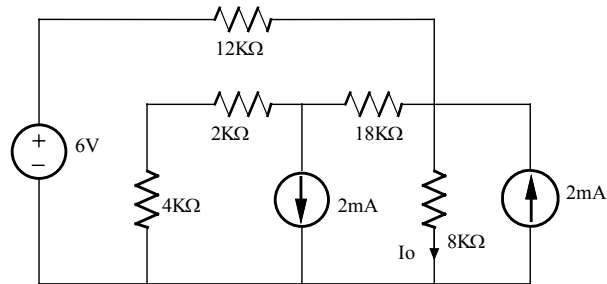

Suggested Solution

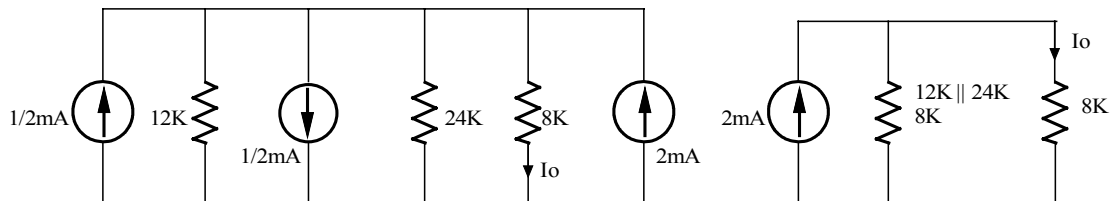
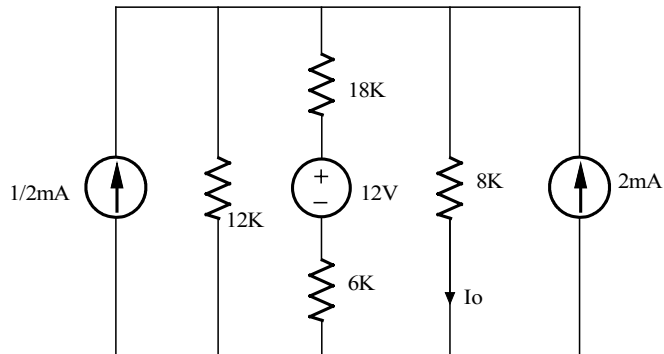

$$I_o = 2\text{m} \left[\frac{8\text{K}}{8\text{K} + 8\text{K}} \right]$$

$I_o = 1\text{ mA}$

Problem 4.31

Find I_o in the network shown using source transformation.

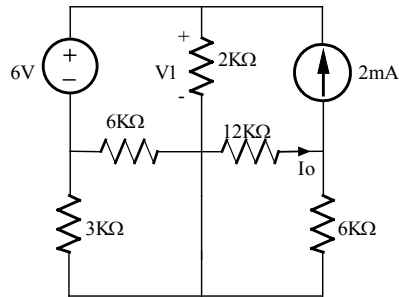

Suggested Solution

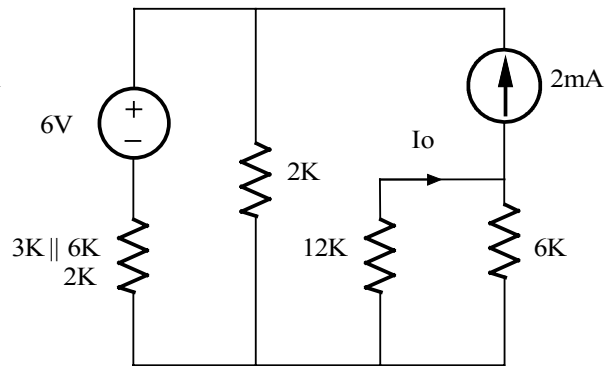
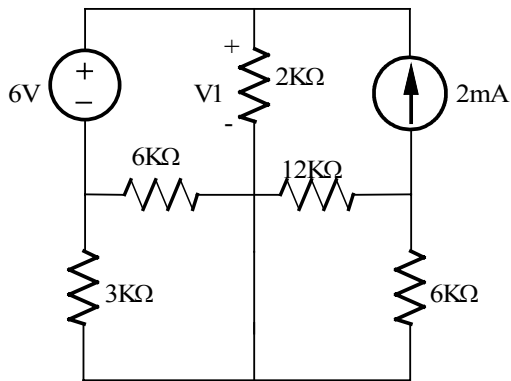

$$I_o = 2\text{m} \left(\frac{6}{6 + 12} \right) = 0.67\text{mA}$$

$$I_o = 0.67 \text{ mA}$$

Problem 4.32

Use Thevenin's Theorem to find V_o in the network shown.

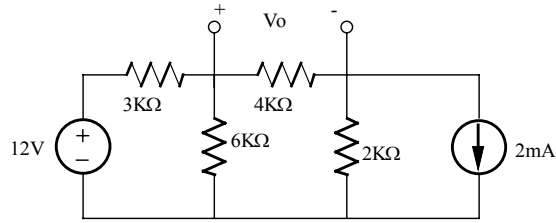

Suggested Solution

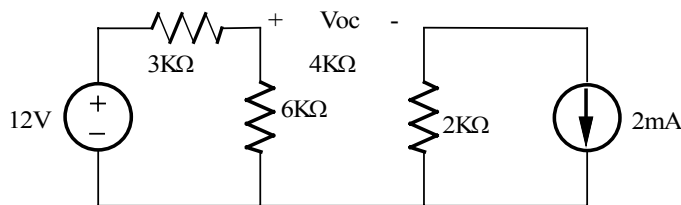

$$V_{oc} = 12 \left(\frac{6K}{9K} \right) + 2m \cdot 2K = 12V$$

$$R_{th} = 3K \parallel 6K + 12K = 4K$$

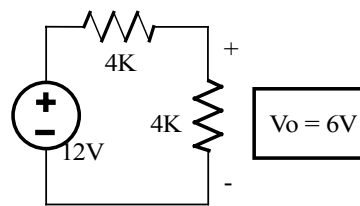
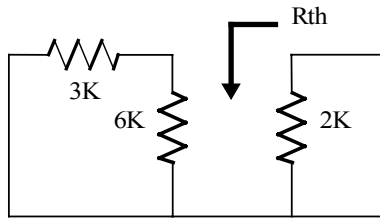

Problem 4.33

Use Thevenin's Theorem to find V_o in the network shown.

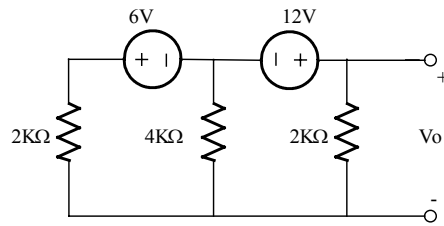

Suggested Solution

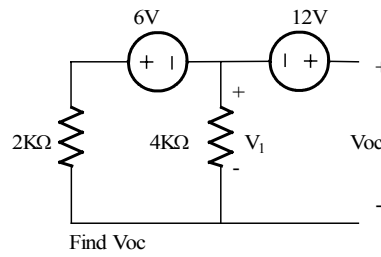
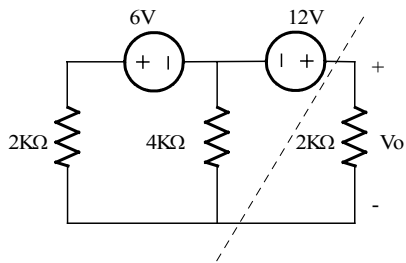

$$V_1 = -6 \left[\frac{4K}{4K + 2K} \right]$$

$$V_1 = -4V$$

$$V_{oc} = 12 + V_1$$

Find V_{oc}

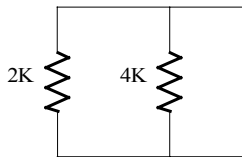

$$R_{th} = 2K \parallel 4K = 1.33K\Omega$$

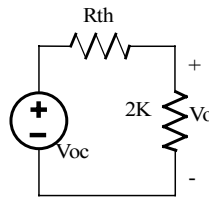

$V_o = 4.8V$

Problem 4.34

Use Thevenin's Theorem to find I_o in the network shown.

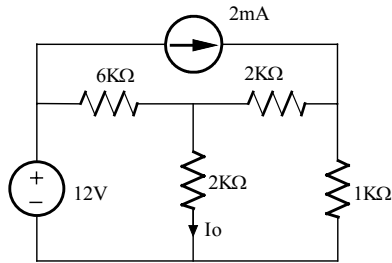

Suggested Solution

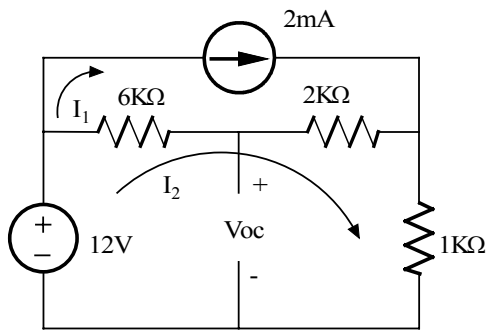

$$I_1 = 2\text{mA}$$

$$-I_2 + 6\text{K}(I_2 - 2\text{m}) + 2\text{K}(I_2 - 2\text{m}) + 1\text{K}I_2 = 0$$

$$I_2 = 28/9 \text{ mA}$$

$$\text{Then } V_{oc} = 12 - 6\text{K}(I_2 - 2\text{m}) = 16/3 \text{ V}$$

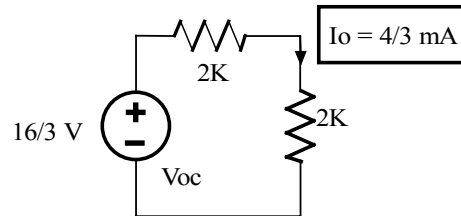
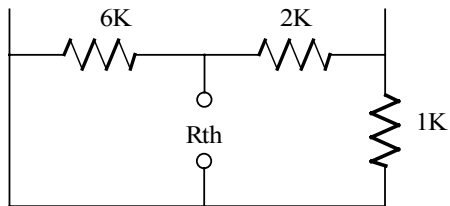

Problem 4.35

Find I_o in the network shown using Thevenin's Theorem.

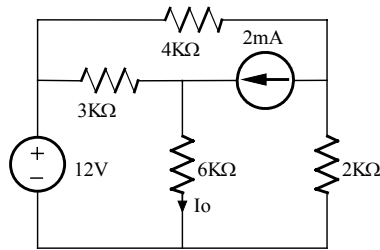

Suggested Solution

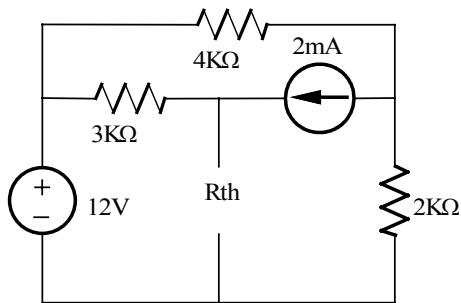

$$V_{oc} = 12 + 3K(2m) = 18V$$

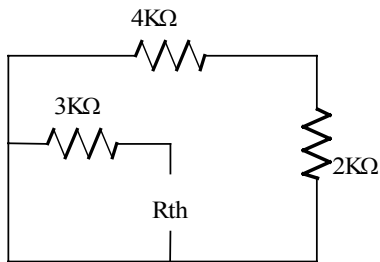

$$R_{th} = 3K\Omega$$

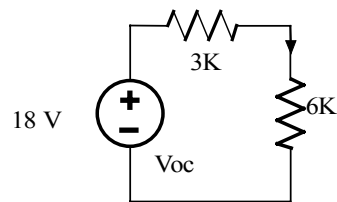

$$I_o = 2 \text{ mA}$$

Problem 4.36

Find V_o in the circuit shown using Thevenin's Theorem.

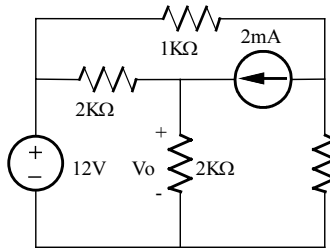

Suggested Solution

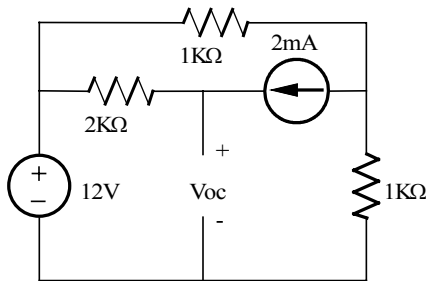

$$V_{oc} = 12 + 2K(2m) = 16V$$

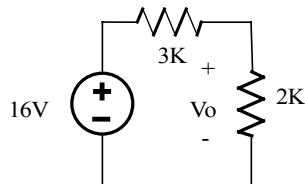
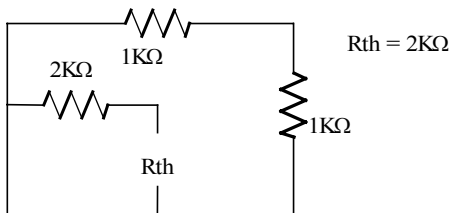

$$V_o = 16 \left(\frac{2K}{2K + 2K} \right) = 8V$$

Problem 4.37

Find I_o in the circuit shown using Thevenin's Theorem.

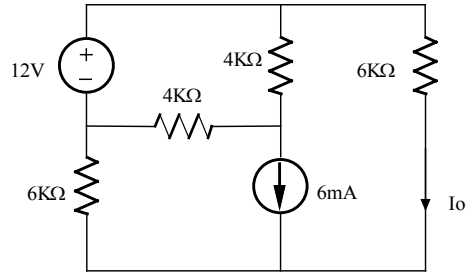

Suggested Solution

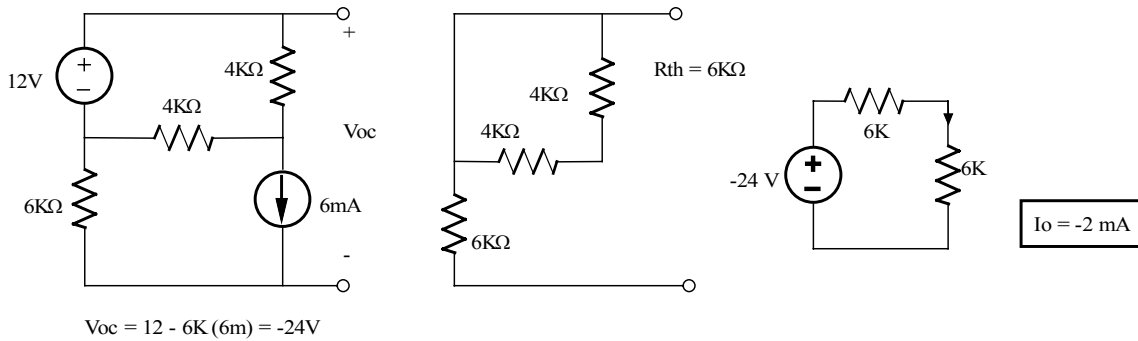

Problem 4.38

Find I_o in the network shown using Thevenin's Theorem.

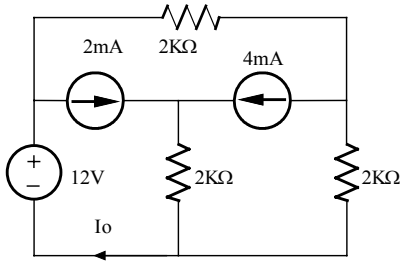

Suggested Solution

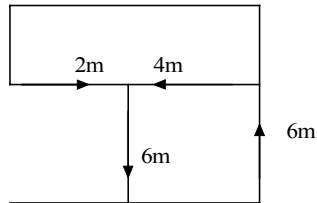
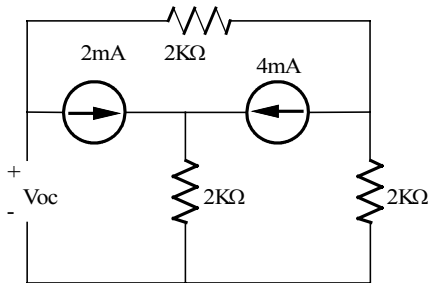

$$V_{oc} = -2K(2m) - 6m(2K) = -16V$$

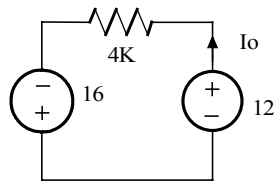
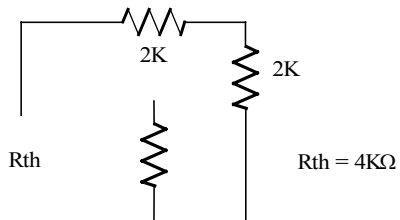

$$I_o = (16 + 12) / (4K)$$

$$I_o = 7mA$$

Problem 4.39

Find V_o in the circuit shown using Thevenin's Theorem.

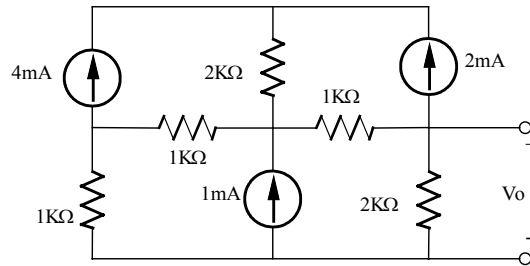

Suggested Solution

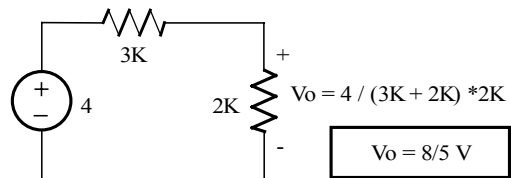
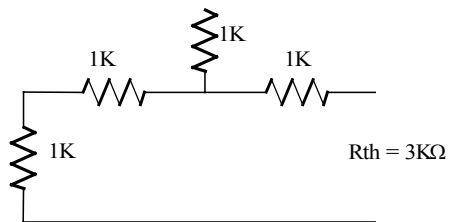
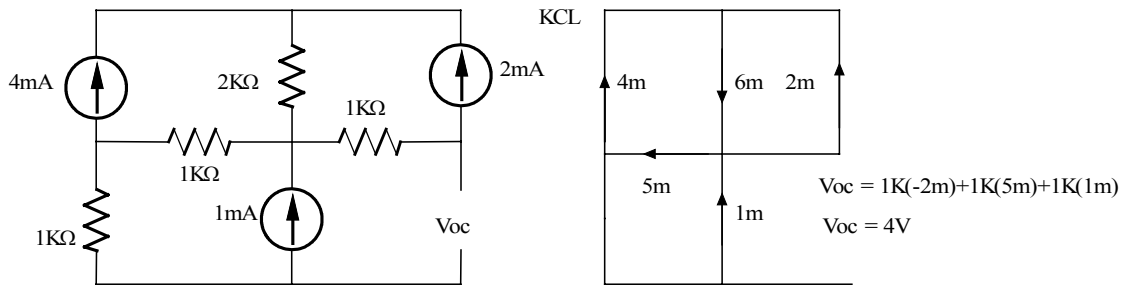

Problem 4.40

Find V_o in the circuit shown using Thevenin's Theorem.

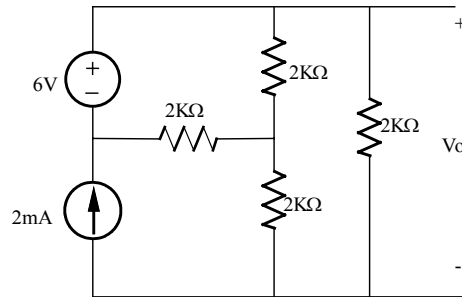

Suggested Solution

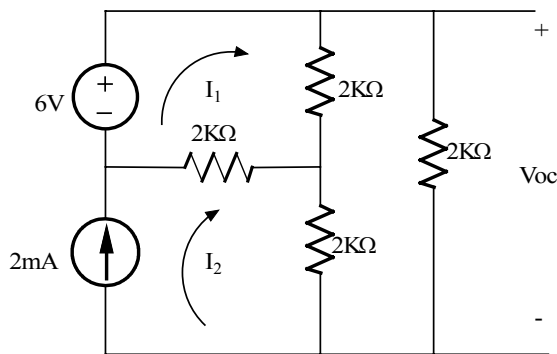

$$\begin{aligned}
 I_2 &= 2\text{m} \\
 -6 + 4\text{K} I_1 + 2\text{K}(I_1 - 2\text{m}) &= 0 \\
 I_1 &= 10/6\text{K} = 5/3 \text{ mA} \\
 V_{oc} &= 4\text{K} I_1 + 2\text{K} I_2 = 4\text{K} (5/3\text{m}) + 2\text{K} 2\text{m} = 32/3\text{V}
 \end{aligned}$$

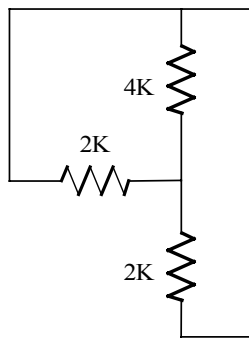

$$R_{th} = 2\text{K} + 4\text{K} \parallel 2\text{K} = 10\text{K}/3$$

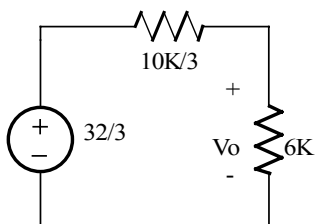

$$V_o = 32/3 \left[\frac{6\text{K}}{6\text{K} + 10/3 \text{ K}} \right] = 48/7 \text{ V}$$

Problem 4.41

Find I_o in the network shown using Thevenin's Theorem.

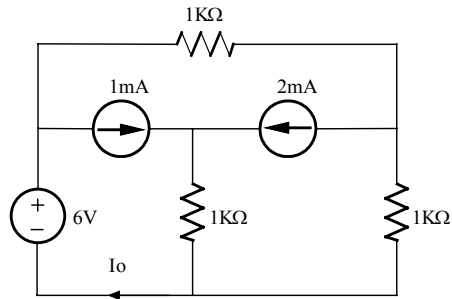

Suggested Solution

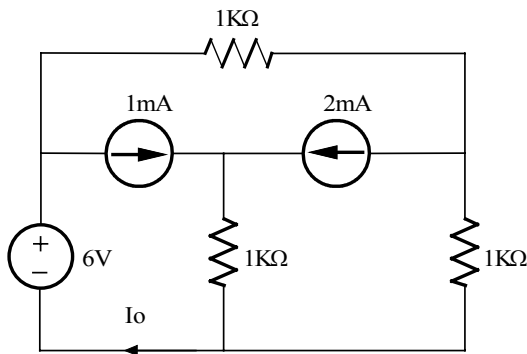

Find V_{oc}

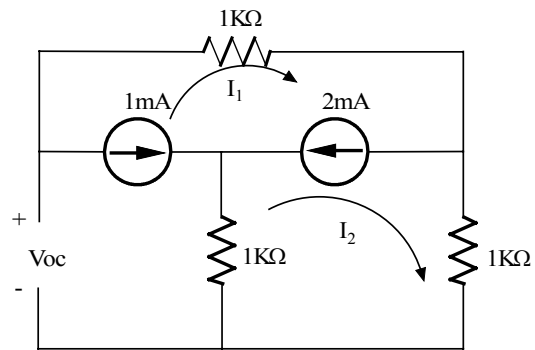

$$I_1 = -1 \text{ mA}$$

$$I_1 - I_2 = 2 \text{ mA}, \quad I_2 = -3 \text{ mA}$$

$$V_{oc} = (1\text{K})I_1 + (1\text{K})I_2 = -4 \text{ V}$$

Find R_{th}

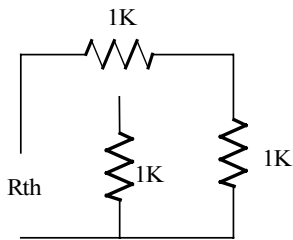

$$R_{th} = 1\text{K} + 1\text{K}$$

$$R_{th} = 2\text{K}\Omega$$

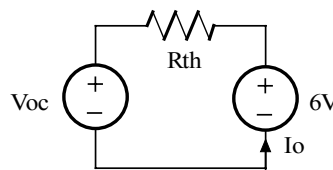

$$-6 + I_o (R_{th}) + V_{oc} = 0$$

$$I_o = (6 - V_{oc}) / R_{th}$$

$I_o = 5 \text{ mA}$

Problem 4.42

Find I_o in the network shown using Thevenin's Theorem.

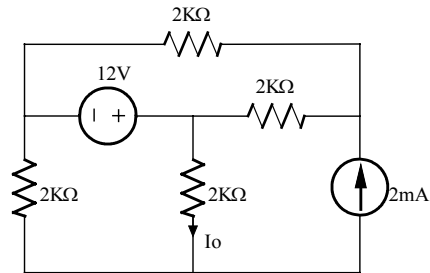

Suggested Solution

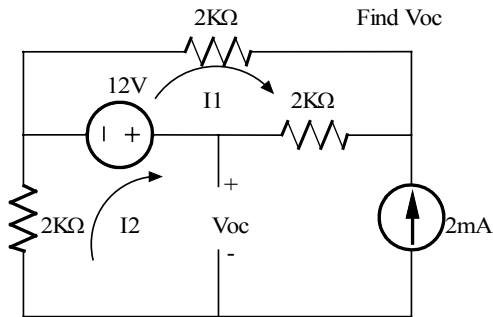

$$I_2 = -2\text{mA}$$

$$V_{oc} = 12 - (4\text{K}) I_2$$

$$V_{oc} = 20\text{V}$$

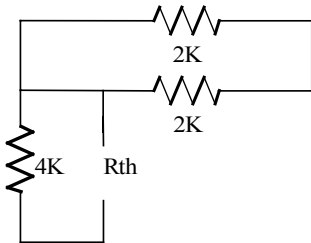

Both $2\text{K}\ \Omega$ resistors are shorted!
 $R_{th} = 4\text{K}\ \Omega$

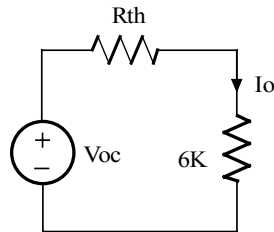

$$I_o = V_{oc} / (R_{th} + 6\text{K})$$

$$I_o = 2\text{mA}$$

Problem 4.43

Find I_o in the network shown using Thevenin's Theorem.

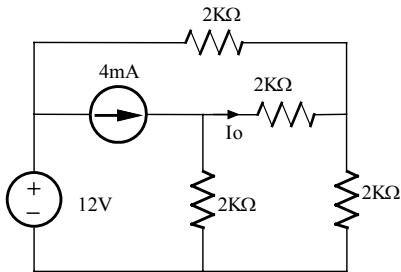

Suggested Solution

Find V_{oc}

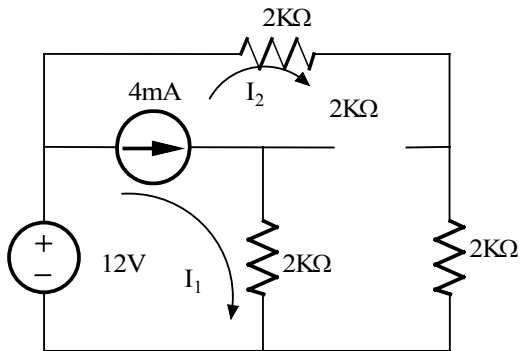

$$I_1 - I_2 = 4\text{mA}$$

$$12 = (2\text{K}) I_2 + 4\text{K} (I_2)$$

so, $I_2 = 2\text{mA}$, $I_1 = 6\text{mA}$

$$V_{oc} = 3\text{K}(I_1 - I_2) - 4\text{K} (I_2)$$

$$V_{oc} = 4\text{V}$$

Find R_{th}

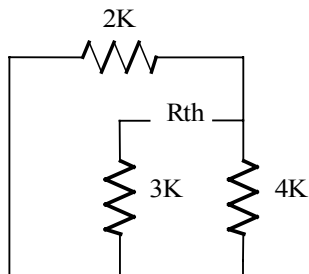

$$R_{th} = 3\text{K} + (2\text{K} \parallel 4\text{K})$$

$$R_{th} = 4.33\text{K}\Omega$$

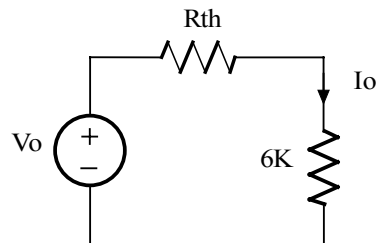

$$I_o = V_{oc} / (R_{th} + 6\text{K})$$

$$I_o = 0.39\text{mA}$$

Problem 4.44

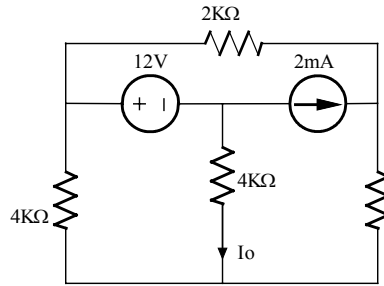

Suggested Solution

Find V_{oc}

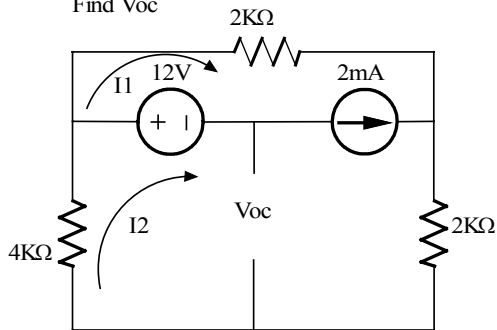

$$\begin{aligned}
 I_2 - I_1 &= 2\text{mA} \\
 (4\text{K})I_2 + (2\text{K})I_1 + (2\text{K})I_2 &= 0 \\
 \text{yields: } I_2 &= 0.5\text{mA} \\
 V_{oc} &= 12 - (4\text{K})I_2 = 10\text{V}
 \end{aligned}$$

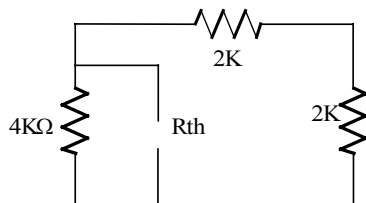

$$\begin{aligned}
 R_{th} &= 4\text{K} \parallel (2\text{K} + 2\text{K}) \\
 R_{th} &= 2\text{K}
 \end{aligned}$$

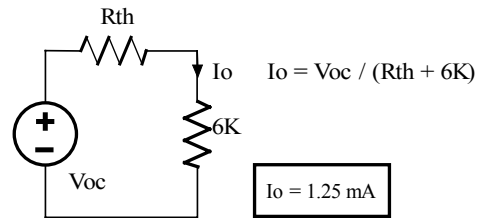

$$I_o = V_{oc} / (R_{th} + 6\text{K})$$

$I_o = 1.25\text{ mA}$

Problem 4.45

Find V_o in the network shown using Thevenin's Theorem.

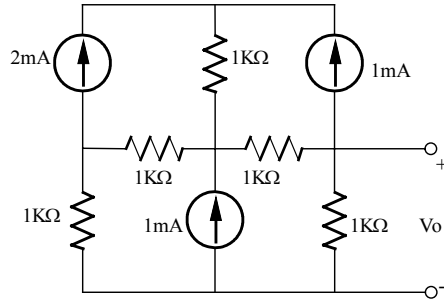

Suggested Solution

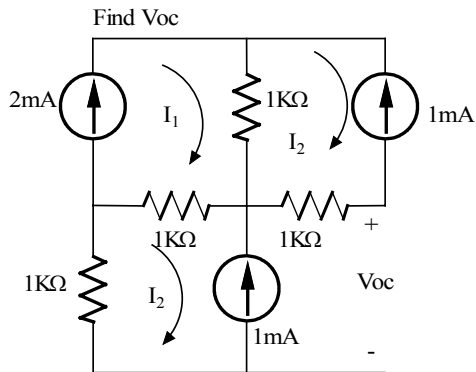

$$I_1 = 2\text{mA}, I_2 = -1\text{mA}, I_3 = 1\text{mA}$$

$$(1\text{K})I_3 + 1\text{K}(I_3 - I_1) - (1\text{K})I_2 + V_{oc} = 0$$

$$V_{oc} = 3\text{V}$$

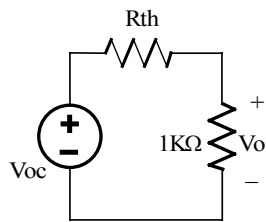
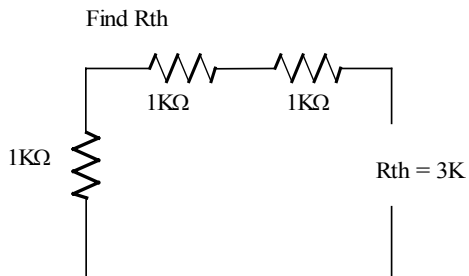

$$V_o = V_{oc} \left[\frac{1\text{K}}{1\text{K} + R_{th}} \right]$$

$$V_o = 0.75\text{V}$$

Problem 4.46

Find V_o in the network shown using Thevenin's Theorem.

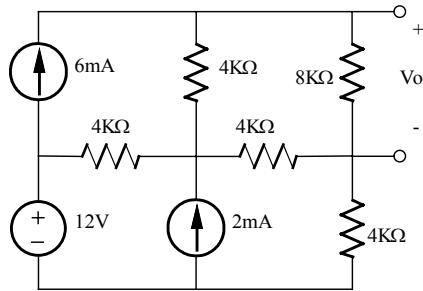

Suggested Solution

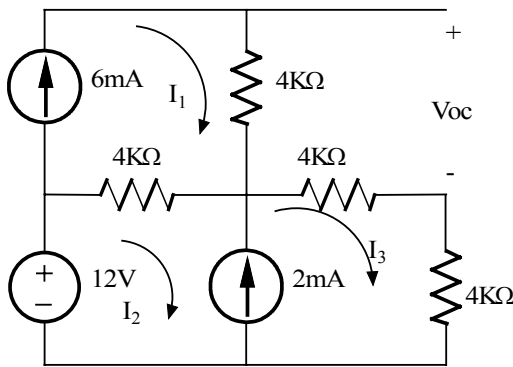

$$I_1 = 6\text{mA}$$

$$I_3 - I_2 = 2\text{mA}$$

$$-I_2 + 8\text{K}(I_2 - I_1) + (28\text{K}) I_3 = 0$$

$$V_{oc} = (4\text{K})I_1 + (24\text{K}) I_3$$

$$\text{Yields } V_{oc} = 74.67\text{V}$$

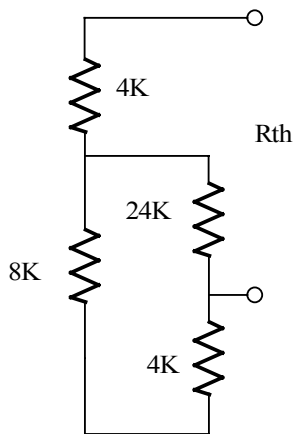

$$R_{th} = 4\text{K} + [(8\text{K} + 4\text{K}) \parallel 24\text{K}]$$

$$R_{th} = 12\text{K}\Omega$$

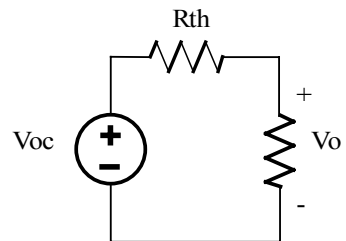

$$V_o = V_{oc} [8\text{K} / (8\text{K} + R_{th})]$$

$V_o = 29.87\text{V}$

Problem 4.47

Use a combination of Thevenin's Theorem and superposition to find V_o in the circuit shown.

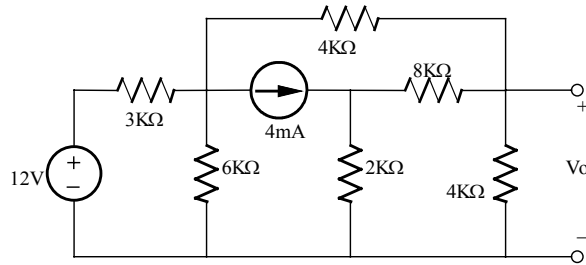

Suggested Solution

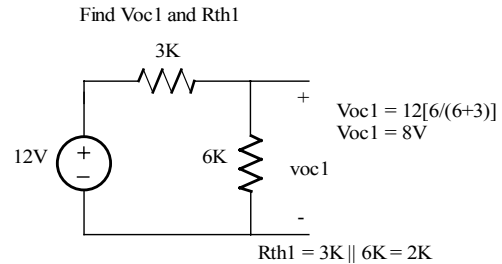
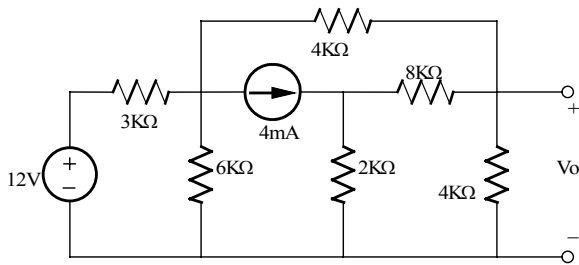

New circuit: Find V_{oc2} due to 8V

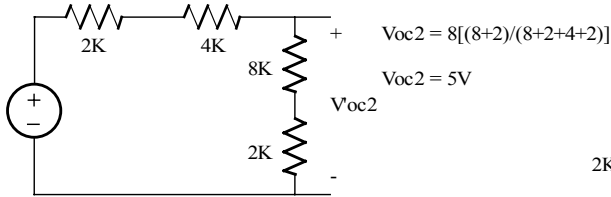

Find V_{oc2} due to 4mA source

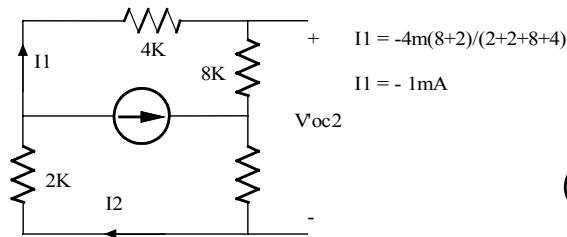

$$I_2 = 4m \left[\frac{4+8}{4+8+2+20} \right] = 3mA$$

$$V_{oc2} = 8K I_1 + 2K I_2 = -2V$$

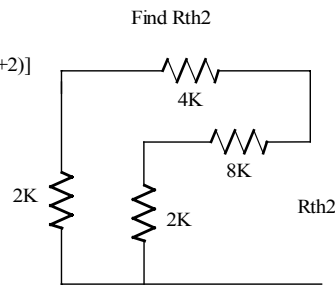

$$R_{th2} = 6K \parallel 10K = 3.75K$$

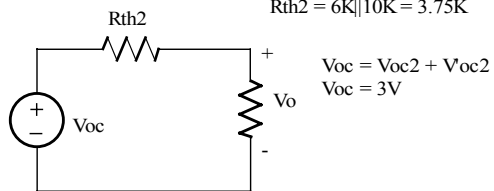

$$V_o = V_{oc} \left[\frac{4K}{R_{th} + 4K} \right]$$

$V_o = 1.55V$

Problem 4.48

In the network shown find V_o using Thevenin's Theorem.

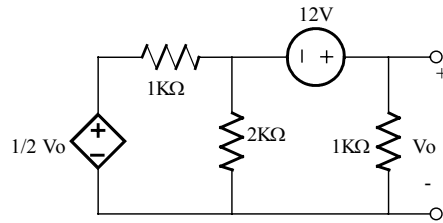

Suggested Solution

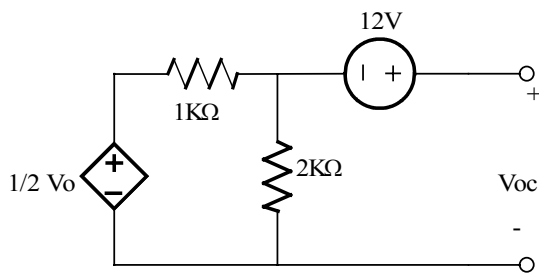

$$V_{oc} = 12 + V_{oc}/2 [2K / (1K + 5K)] = 12 + V_{oc}/3$$

$$V_{oc} = 18V$$

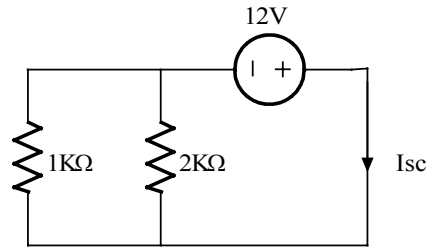
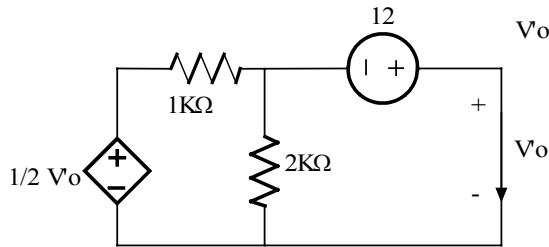

$$I_{sc} = 12 / (1K \parallel 2K) = 18mA, \quad R_{th} = V_{oc}/I_{sc} = 1K\Omega$$

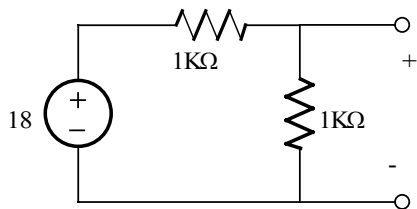

$V_o = 9V$

Problem 4.49

Find the Thevenin equivalent of the network shown at the terminals A-B.

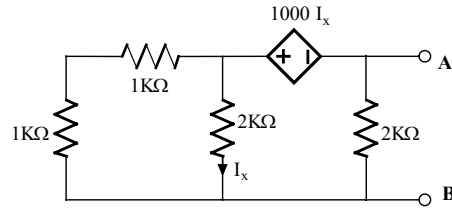

Suggested Solution

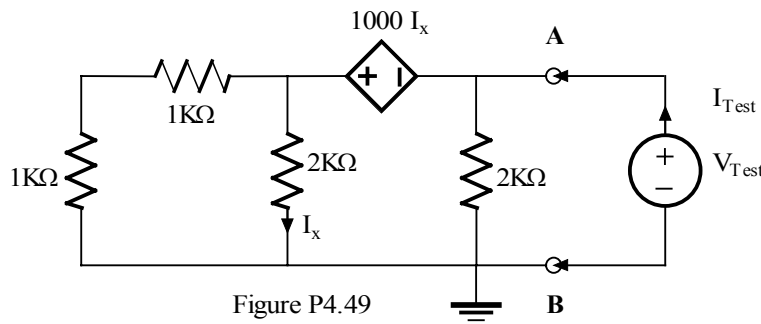

Figure P4.49

Apply a test source, V_{Test}

$$R_{AB} = V_{Test} / I_{Test}$$

$$I_x = \frac{V_x}{2K} \quad V_x - V_{Test} = 1000I_x = \frac{V_x}{2}$$

$$\text{So, } V_x = 2V_{Test}$$

At the reference node,

$$I_{Test} = \frac{V_{Test}}{2K} + \frac{V_x}{2K} + \frac{V_x}{1K+1K} = \frac{1}{2K} [V_{Test} + 2V_x] = \frac{1}{2K} [5V_{Test}]$$

$$R_{AB} = \frac{V_{Test}}{I_{Test}} = \frac{2K}{5} = 400\Omega$$

$$\boxed{R_{AB} = 400\Omega}$$

Problem 4.50

Find the Thevenin equivalent of the network shown at the terminals A-B.

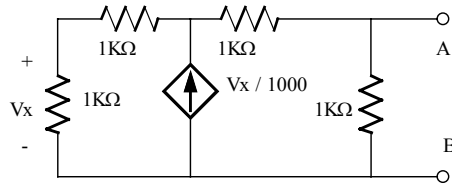

Suggested Solution

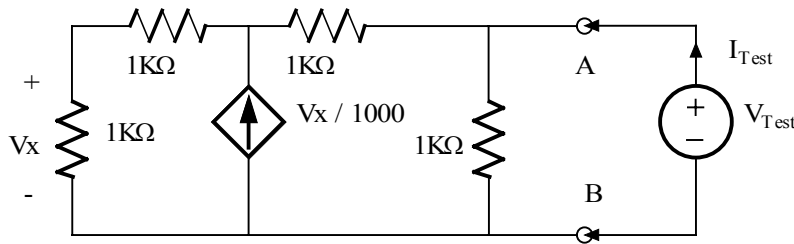

Apply a test source,

$$V_{Test}, R_{AB} = V_{Test} / I_{Test}$$

$$V_x = V_y \left[\frac{1K}{1K+1K} \right] \Rightarrow V_x = \frac{V_y}{2}$$

$$\text{At } V_y: \frac{V_x}{1K} = \frac{V_y}{2K} + \frac{V_{Test}-V_y}{2K} \Rightarrow \text{yields } V_y = V_{Test}$$

$$\text{At } V_{Test}: I_{Test} = \frac{V_{Test}}{1K} + \frac{V_{Test}-V_y}{2K} \Rightarrow \boxed{\frac{V_{Test}}{I_{Test}} = R_{AB} = 1K\Omega}$$

Problem 4.51

Find V_o in the network shown using Thevenin's Theorem.

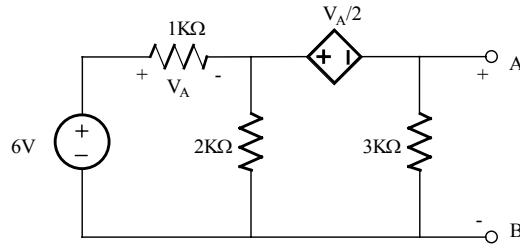

Suggested Solution

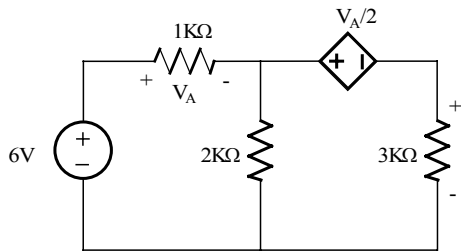

Find V_{oc}

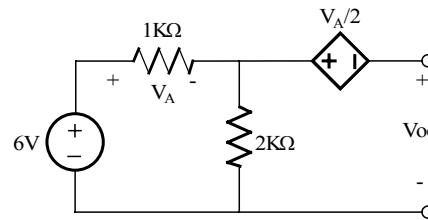

$$V_A = 6 [1K / (2K+1K)]$$

$$V_A = 2V$$

$$V_{oc} = -V_A/2 - V_A + 6 = 3V$$

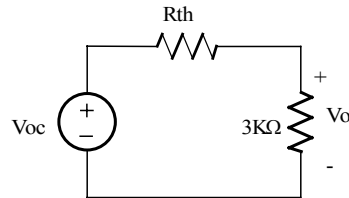
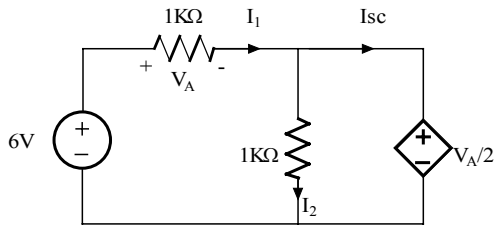

$$R_{th} = V_{oc} / I_{sc}$$

$$R_{th} = 1K\Omega$$

$$V_o = V_{oc} [3K / (3K + R_{th})] = 2.25V$$

$$V_o = 2.25V$$

$$V_A = 6 - V_A/2 \Rightarrow V_A = 4V$$

$$I_1 = V_A / 1K = 4mA, \quad I_2 = (V_A/2) / 2K = 1mA$$

$$I_{sc} = I_1 - I_2 = 3mA$$

Problem 4.52

Find V_o in the network shown using Thevenin's Theorem.

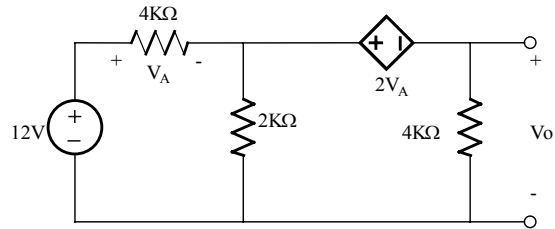

Suggested Solution

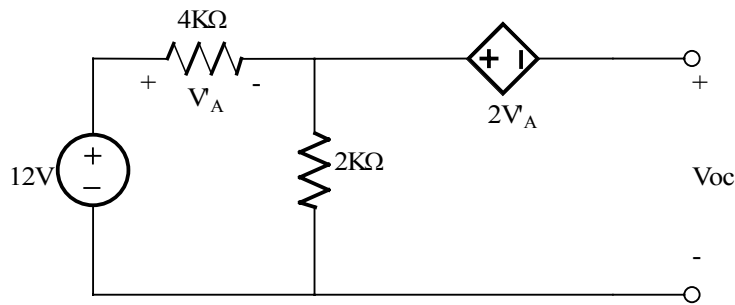

Using voltage division
 $V_A = 12(4K/6K) = 8V$

Figure P4.52

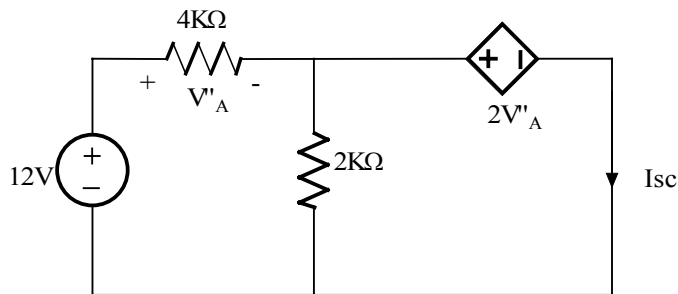

KVL outer loop
 $-12 + V'_A + 2V'_A = 0$
 $V'_A = 4V$

If $V'_A = 4V$

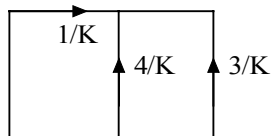

$I_{sc} = -3mA$ and $R_{th} = V_{oc}/I_{sc} = (-12)/(-3m) = 4K\Omega$

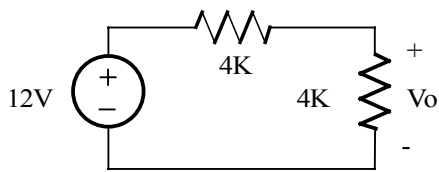

$V_o = -6V$

Problem 4.53

Find V_o in the circuit shown using Thevenin's Theorem.

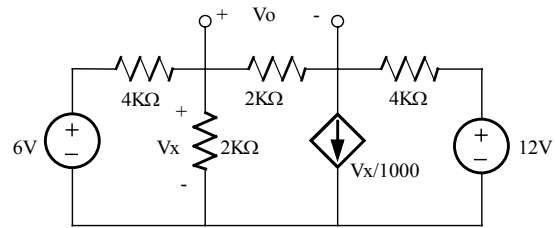

Suggested Solution

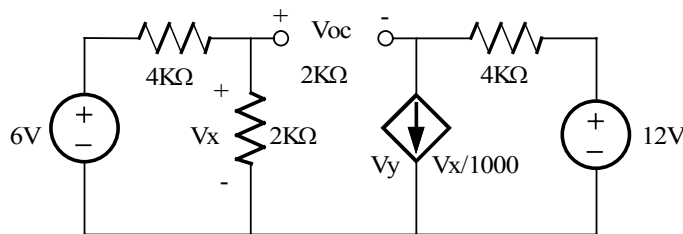

$$V_x = 6 \left[\frac{2K}{4K + 2K} \right] = 2V$$

$$V_y = 12 - 4K \left(\frac{V_x}{1000} \right) = 4V$$

$$V_{oc} = V_x + V_y = -2V$$

Find I_{sc}

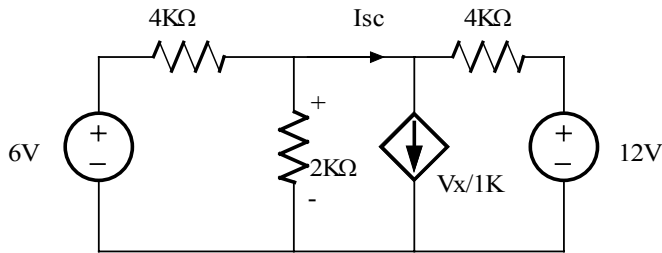

$$I_{sc} = \frac{V_x}{1K} + \frac{V_x - 12}{4K}$$

$$(6 - V_x)/4K = V_x / 2K + I_{sc}$$

$$\left. \begin{aligned} V_x &= 9/4 \text{ V} \\ I_{sc} &= -0.19 \text{ mA} \end{aligned} \right\}$$

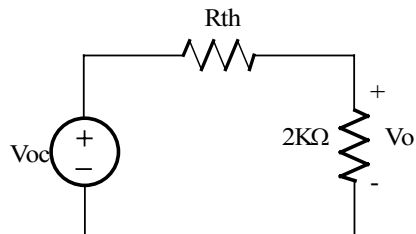

$$R_{th} = V_{oc} / I_{sc} = 10.67 \text{ K}\Omega$$

$$V_o = V_{oc} \left[\frac{2K}{2K + R_{th}} \right]$$

$$V_o = -0.32 \text{ V}$$

Problem 4.54

Use Thevenin's Theorem to find V_o in the circuit shown.

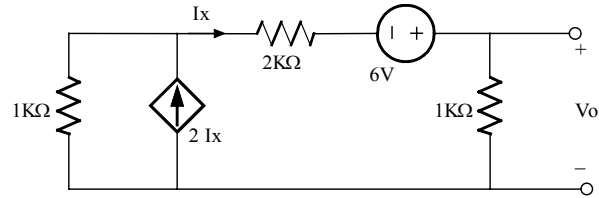

Suggested Solution

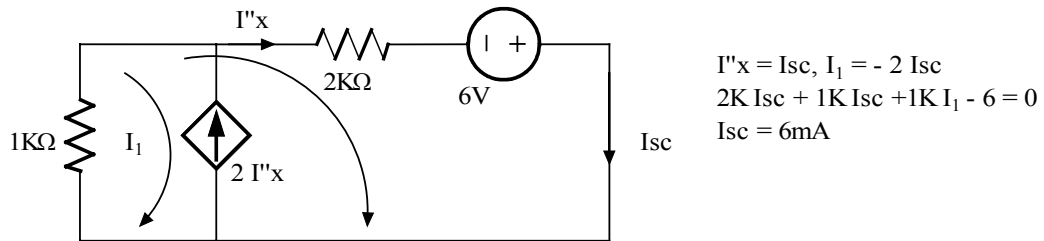
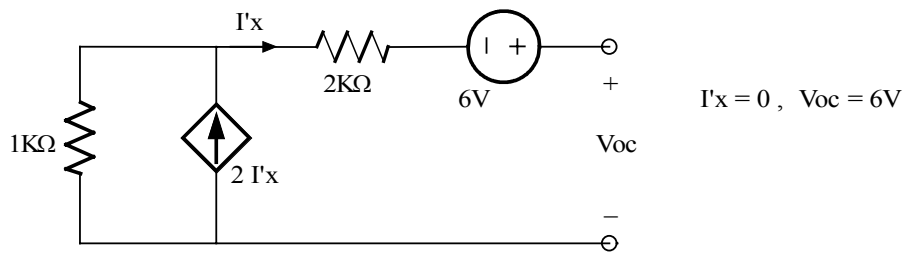

$R_{th} = V_{oc} / I_{sc} = 1K\Omega$

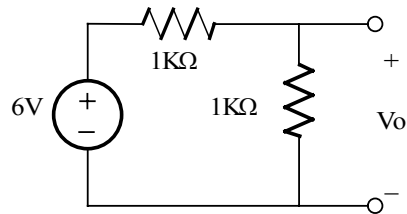

$V_o = 3V$

Problem 4.55

Use Thevenin's Theorem to Find I_o in the circuit shown.

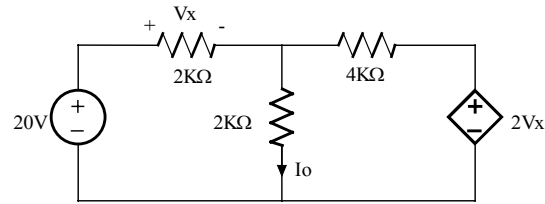

Suggested Solution

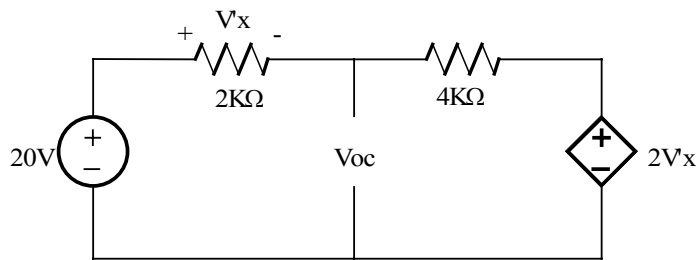

$$-20 + 2K I + 4K I + 2 V_x = 0$$

$$V_x = 2K (I)$$

$$I = 2\text{mA}$$

$$V_{oc} = 20 - 2\text{m} (2K) = 16\text{V}$$

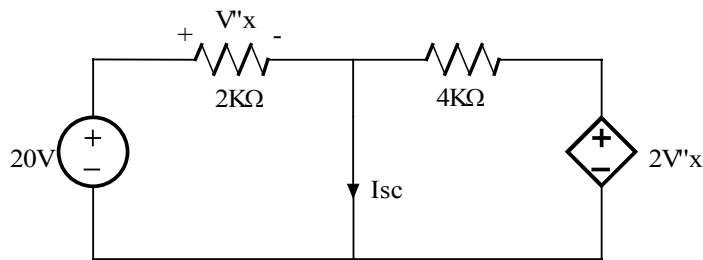

$$V'_x = 20$$

$$I_{sc} = 20 / 2K + 40 / 4K = 20 \text{ mA}$$

$$R_{th} = V_{oc} / I_{sc} = 4/5 \text{ K}\Omega$$

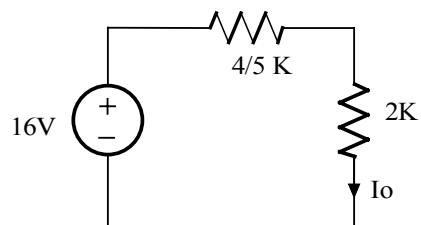

$$I_o = 16 / (2 + 4/5)K = 40 / 7K = 5.71 \text{ mA}$$

$$I_o = 5.71 \text{ mA}$$

Problem 4.56

Find V_o in the network shown using Thevenin's Theorem.

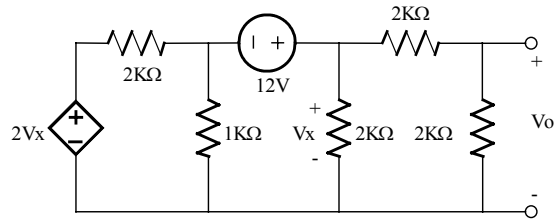

Suggested Solution

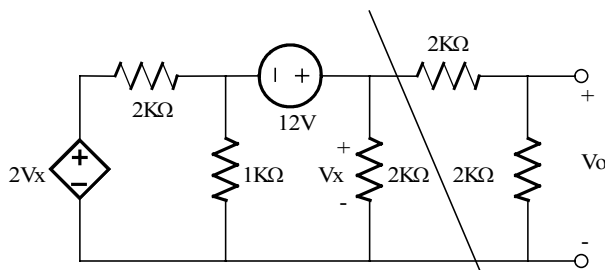

Find V_{oc}

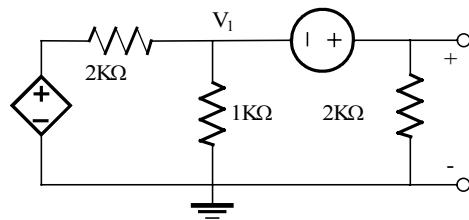

$$(V_x - V_1)/2K = V_1/1K + V_x/2K$$

yields,
 $V_x = V_{oc} = 18 \text{ V}$

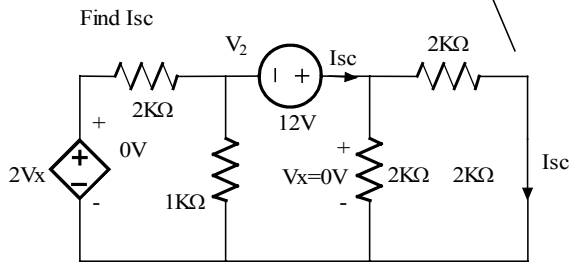

Find I_{sc}

Now, $V_x = 0!$ and $V_2 = -12\text{V}$
 $V_2/2K + V_2/1K + I_{sc} = 0$, $I_{sc} = 18 \text{ mA}$

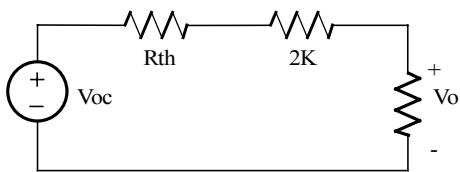

$$R_{th} = V_{oc}/I_{sc} = 1K$$

$$V_o = V_{oc} [2K / (2K + 2K + R_{th})] = 7.2\text{V}$$

$V_o = 7.2\text{V}$

Problem 4.57

Use Thevenin's Theorem to find V_o in the network shown.

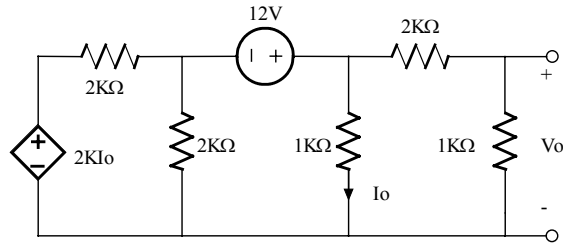

Suggested Solution

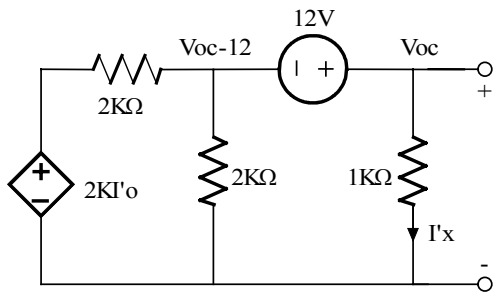

Supernode - KCL

$$(V_{oc} - 12 - 2KI'_x) / 2K + (V_{oc} - 12) / 2K + V_{oc} / 1K = 0$$

$$I'_x = V_{oc} / 1K \quad \text{Then } V_{oc} = 12 \text{ V}$$

1K Resistor is shorted
 $I''_x = 0$

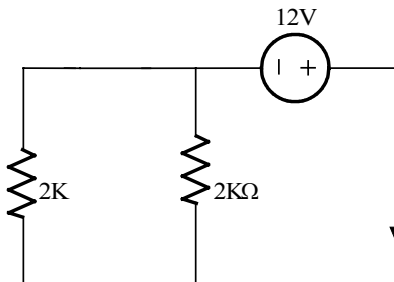

$$I_{sc} = 12\text{mA} \quad \text{and} \quad R_{th} = V_{oc} / I_{sc} = 1K\Omega$$

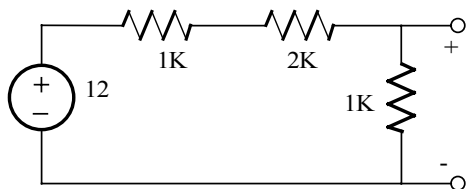

$$V_o = 12(1K/4K) = 3V$$

Problem 4.58

Find V_o in the network shown using Thevenin's Theorem.

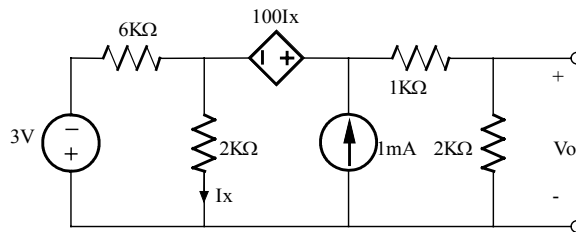

Suggested Solution

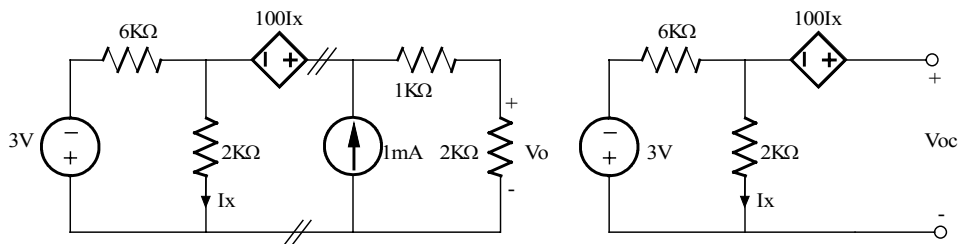

$$I_x = -3/8K = -0.38 \text{ mA}$$

$$3 + (6K)I_x - (1K)I_x + V_{oc} = 0$$

$$\begin{aligned} V_x &= 2000I_x \\ V_x &= -1000 I_x \\ V_x &= 0 \text{ and } I_x = 0A \\ \text{Now, } -3 / 6K &= I_{sc} \Rightarrow I_{sc} = -0.5mA \end{aligned}$$

$$\begin{aligned} V_{oc} &= -1.13V \\ R_{th} &= V_{oc} / I_{sc} = 2.25 \text{ K}\Omega \end{aligned}$$

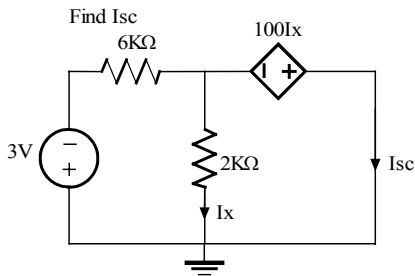

Find I_{sc}

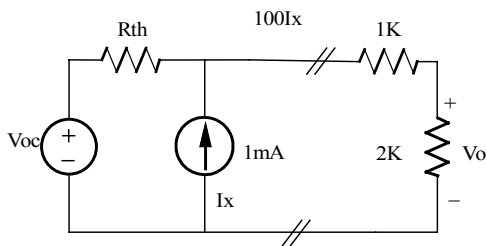

$$V_{oc} = -1.13V, R_{th} = 2.25K$$

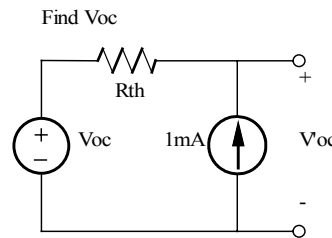

Find V_{oc}

$$\begin{aligned} V_{oc} &= (1m)R_{th} + V_{oc} \\ V_{oc} &= 1.13V \end{aligned}$$

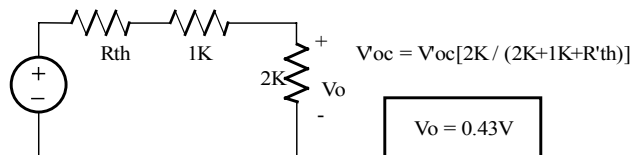
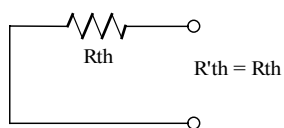

$V_o = 0.43V$

Problem 4.59

Use Thevenin's Theorem to Find V_o in the circuit shown.

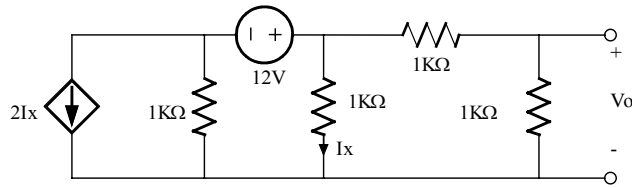

Suggested Solution

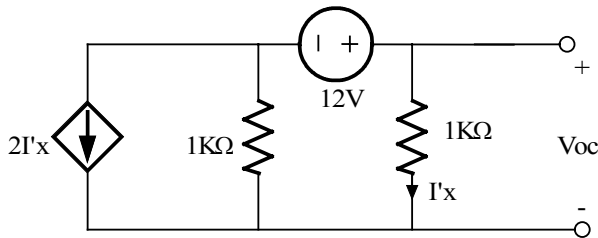

$$(V_{oc} - 12) / 1K + 2I'x + V_{oc}/1K = 0$$

$$I'x = V_{oc} / 1K$$

$$V_{oc} = 3V$$

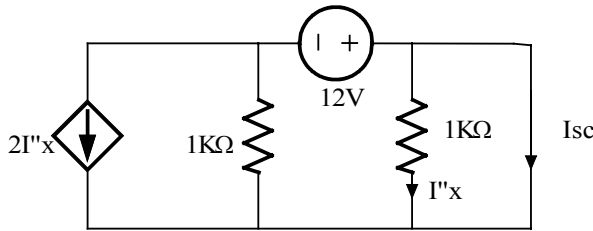

$I''x = 0$, The network is reduced to

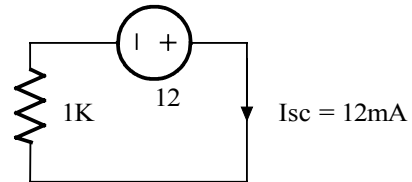

$$R_{th} = V_{oc} / I_{sc} = 3 / 12m = 0.25 K\Omega$$

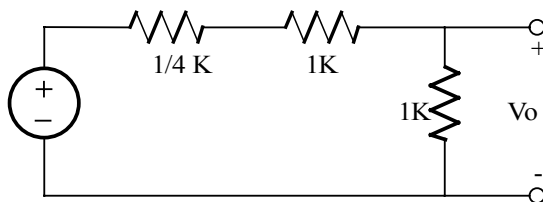

$$V_o = [3 / (2 + 1/4)K] 1K = 4/3 V$$

$V_o = 4/3 V$

Problem 4.60

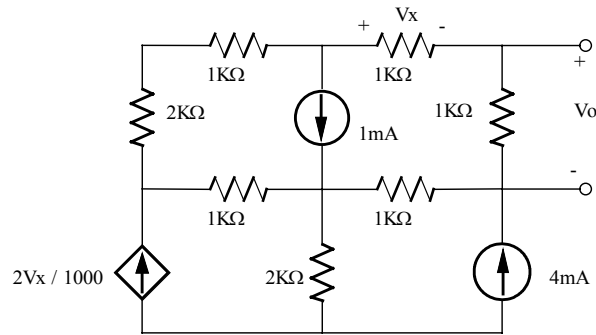

Suggested Solution

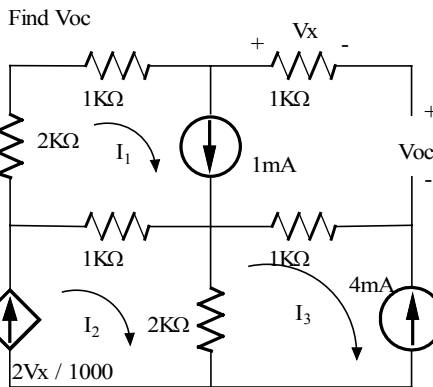
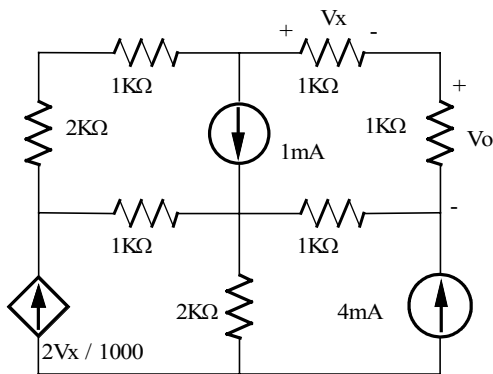

$$\begin{aligned} V_x &= 0 \\ I_1 &= 1\text{mA} \\ I_3 &= -4\text{mA} \\ I_2 &= 0 \end{aligned}$$

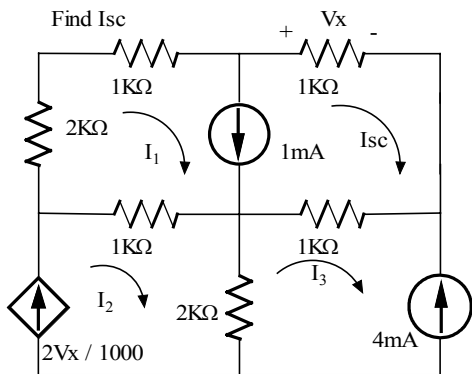

$$(3K)I_1 + V_{oc} - (1K)I_3 + 1K(I_1 - I_2) = 0$$

$$V_{oc} = -8V$$

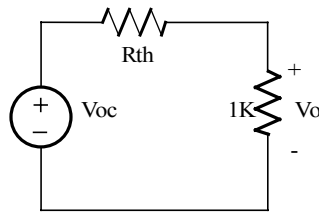

$$R_{th} = V_{oc} / I_{sc}$$

$$R_{th} = 8K$$

$$V_o = V_{oc} [1K / (1K + R_{th})]$$

$$\begin{aligned} I_1 - I_{sc} &= 1\text{mA}, \quad I_3 = -4\text{mA} \\ V_x &= -I_{sc}(1K), \quad I_2 = 2V_x / 1K \\ 3KI_1 + (1K)I_{sc} + 1K(I_{sc} - I_3) + 1K(I_1 - I_2) &= 0 \\ \text{yields, } I_{sc} &= -1\text{mA} \end{aligned}$$

$V_o = -0.89\text{ V}$

Problem 4.61

Use Norton's Theorem to find V_o in the network shown.

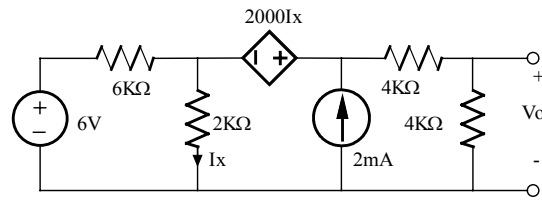

Suggested Solution

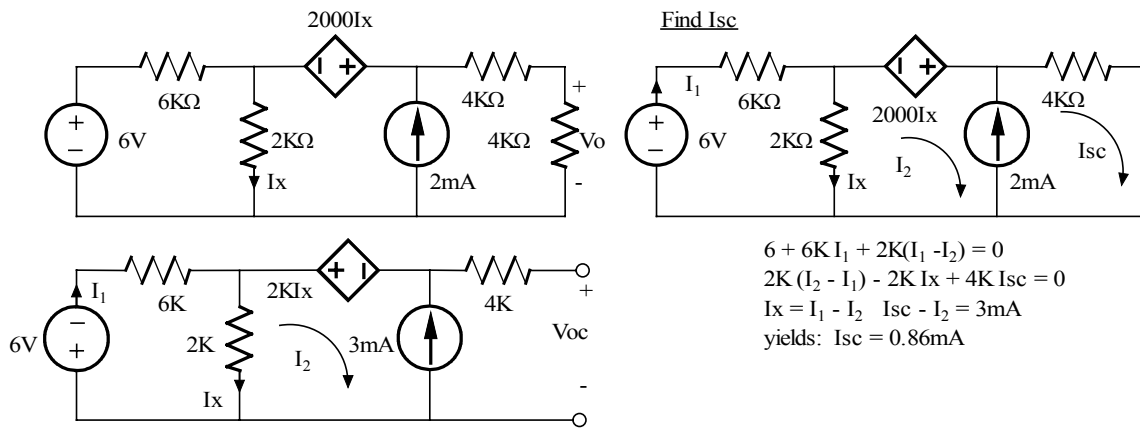

$$\begin{aligned}
 6 + 6K I_1 + 2K(I_1 - I_2) &= 0 \\
 2K(I_2 - I_1) - 2K I_x + 4K I_{sc} &= 0 \\
 I_x = I_1 - I_2 \quad I_{sc} - I_2 &= 3mA \\
 \text{yields: } I_{sc} &= 0.86mA
 \end{aligned}$$

Same equations as those used to find I_{sc} except $I_{sc} \rightarrow 0$. Also,

$$V_{oc} = 2K I_x + 2K I_x$$

$$\text{yields: } V_{oc} = 6V$$

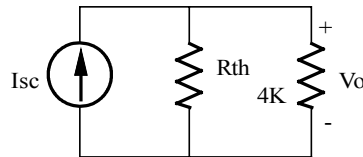

$$\begin{aligned}
 R_{th} &= V_{oc} / I_{sc} = 7K \\
 V_o &= I_{sc} [R_{th} \parallel 4K]
 \end{aligned}$$

$$V_o = 2.18V$$

Problem 4.62

Find I_o in the network shown using Norton's Theorem

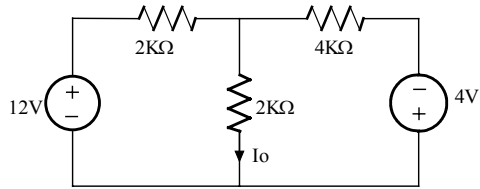

Suggested Solution

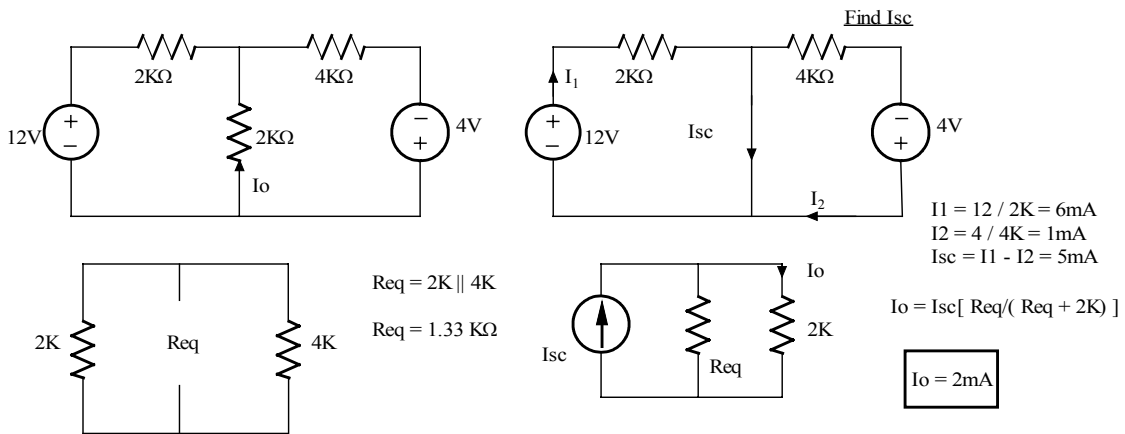

Problem 4.63

Use Norton's Theorem to find I_o in the circuit shown.

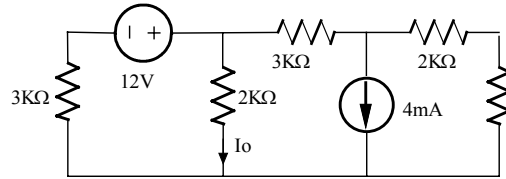

Suggested Solution

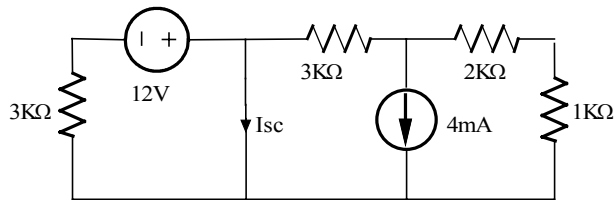

$$I_{sc} = 12 / 3K - 4m[3K / (3K + 3K)]$$

$$I_{sc} = 2mA$$

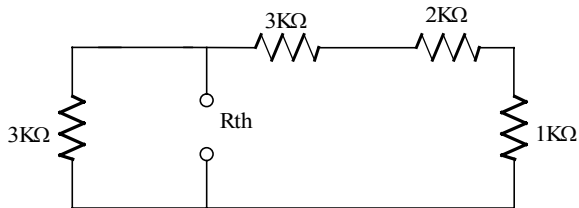

$$R_{th} = 3K \parallel 6K = 2K\Omega$$

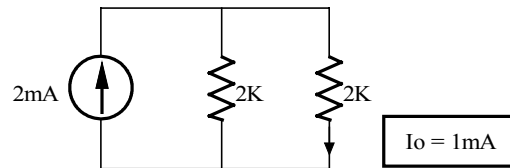

Problem 4.64

Find I_o in the network shown using Norton's Theorem.

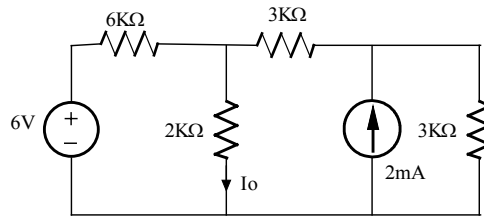

Suggested Solution

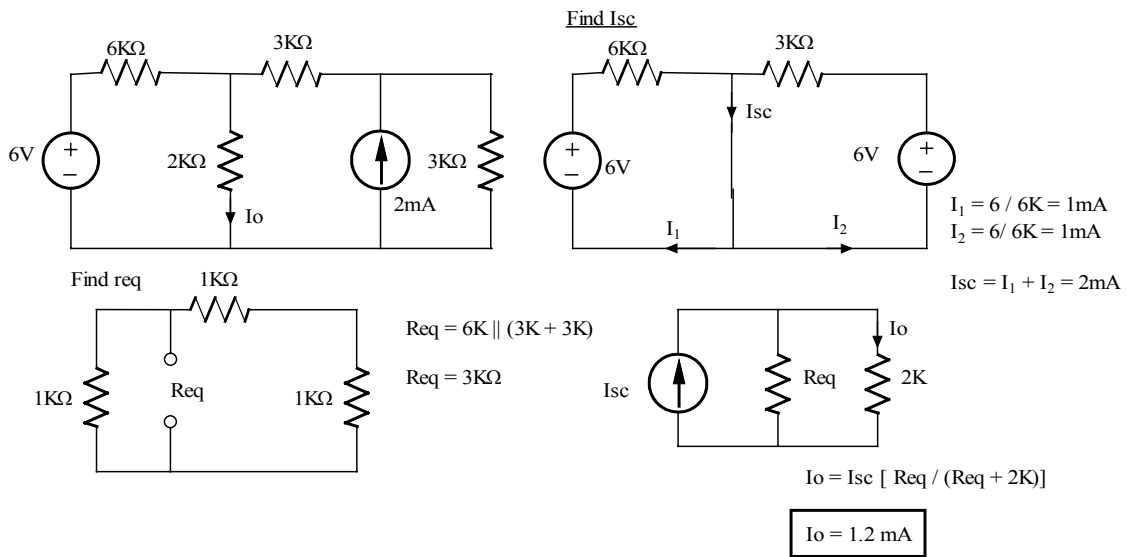

Problem 4.65

Find I_o in the network shown using Norton's Theorem.

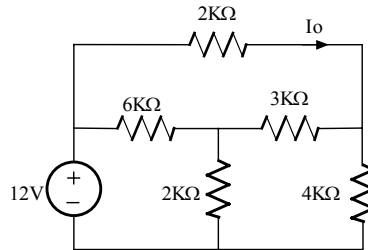

Suggested Solution

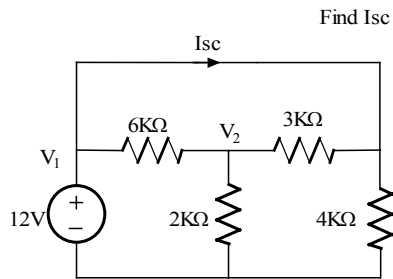

$$V_1 = 12V$$

$$(V_1 - V_2) / 6K + (V_1 - V_2) / 3K = V_2 / 2K$$

yields, $V_2 = 6V$

$$I_{sc} = (V_1 - V_2) / 3K + V_1 / 4K = 5mA$$

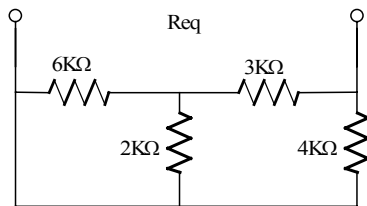

$$R_{eq} = 4K \parallel [3K + (6K \parallel 2K)]$$

$$R_{eq} = 2.12 K$$

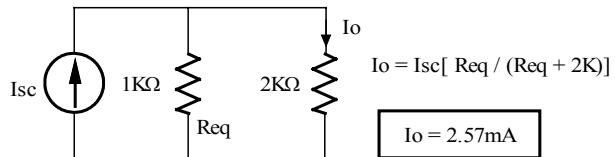

Problem 4.66

Use Norton's Theorem to find V_o in the network shown.

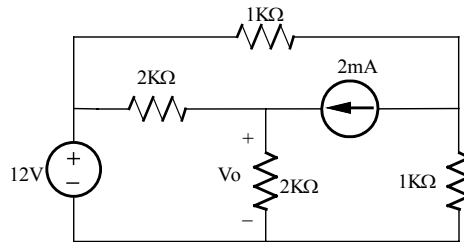

Suggested Solution

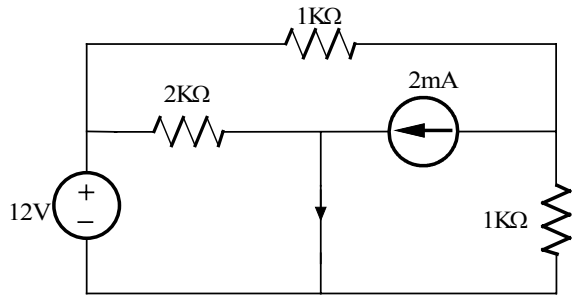

$$I_{sc} = 12 / 2K + 2 / 1K = 8\text{mA}$$

$$R_{th} = 2K$$

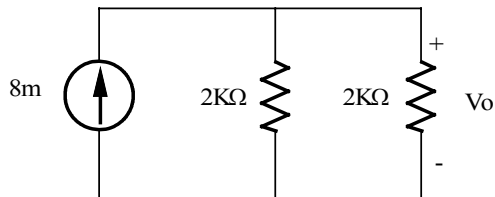
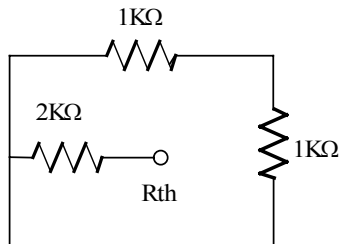

$V_o = 8V$

Problem 4.67

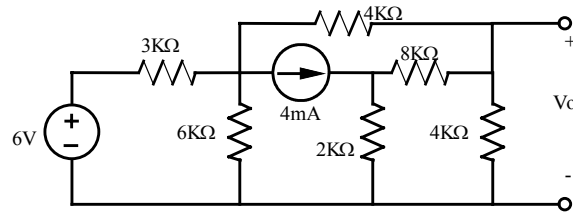

Suggested Solution

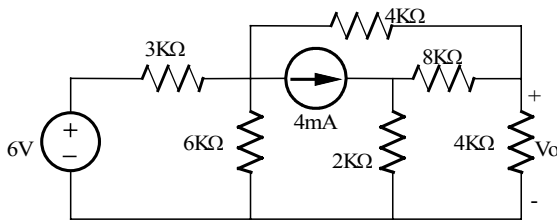

Find Isc

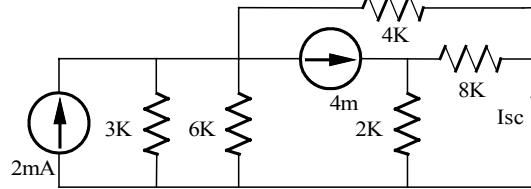

Find Req

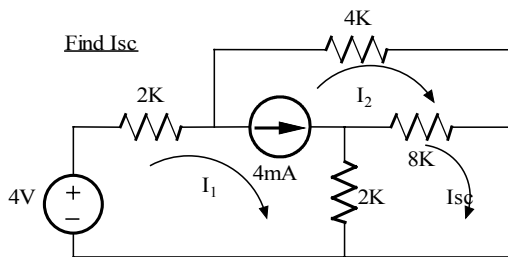
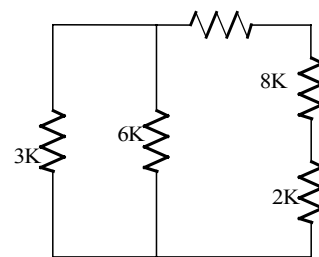

$$I_1 - I_2 = 4\text{mA}, \quad 2\text{K}(I_{sc} - I_1) + 8\text{K}(I_{sc} - I_2) = 0$$

$$4 = (2\text{K}) I_1 + (4\text{K}) I_2$$

yields: $I_{sc} = 0.1333 \text{ mA}$

$$R_{eq} = (8\text{K} + 2\text{K}) \parallel [4\text{K} + (6\text{K} \parallel 3\text{K})]$$

$$R_{eq} = 3.75 \text{ K}$$

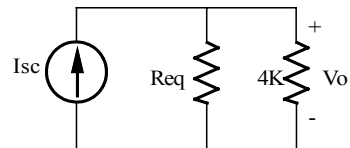

$$V_o = I_{sc} [R_{eq} \parallel 4\text{K}] = 258\text{mV}$$

$V_o = 258 \text{ mV}$

Problem 4.68

Given the linear circuit shown, it is known that when a $2\text{-K}\Omega$ load is connected to the terminals A-B, the load current is 10mA . If a $10\text{-K}\Omega$ load is connected to the terminals the load current is 6mA . Find the current in a $20\text{K}\Omega$ load.

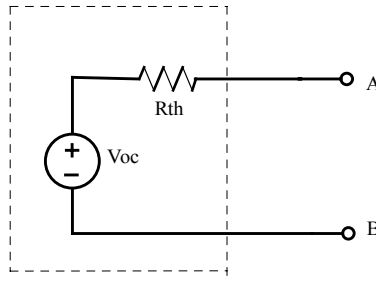

Suggested Solution

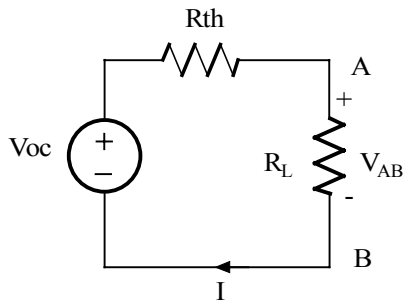

$$(R_{th} + R_L) I = V_{oc}$$

$$\text{if } R_L = 2\text{K}\Omega, I = 10\text{mA} \Rightarrow V_{oc} = 20 + 0.01R_{th}$$

$$\text{if } R_L = 10\text{K}\Omega, I = 6\text{mA} \Rightarrow V_{oc} = 60 + 0.006R_{th}$$

$$\text{yield } V_{oc} = 120\text{V} \text{ and } R_{th} = 10\text{K}\Omega$$

$$\text{If } R_L = 20\text{K}\Omega, I = V_{oc} / (R_L + R_{th})$$

$$I = 4 \text{ mA}$$

Problem 4.69

If an $8\text{-K}\Omega$ load is connected to the terminals of the network shown, $V_{AB} = 16\text{V}$. If a $2\text{-K}\Omega$ load is connected to the terminals $V_{AB} = 8\text{V}$. Find V_{AB} if a $20\text{K}\Omega$ load is connected to the terminals.

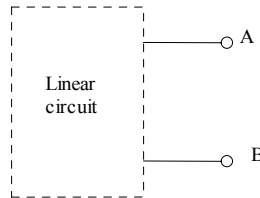

Suggested Solution

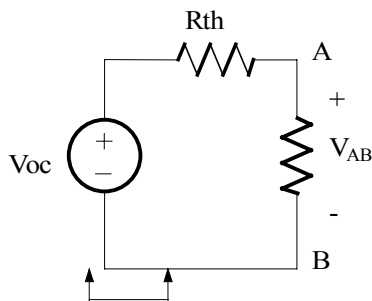

Thevenin eq.
for linear circuit

$$V_{AB} = \text{Voc} \left[\frac{R_L}{R_L + R_{th}} \right] \Rightarrow \text{Voc} = V_{AB} \left[1 + \frac{R_{th}}{R_L} \right]$$

$$\text{If } R_L = 8\text{K}\Omega, V_{AB} = 16\text{V} \Rightarrow \text{Voc} = 16 \left[1 + \frac{R_{th}}{8\text{K}} \right]$$

$$\text{If } R_L = 2\text{K}\Omega, V_{AB} = 8\text{V} \Rightarrow \text{Voc} = 8 \left[1 + \frac{R_{th}}{2\text{K}} \right]$$

$$\text{yield: } R_{th} = 4\text{K}\Omega \text{ and } \text{Voc} = 24\text{V}$$

$$\text{If } R_L = 20\text{K}\Omega, V_{AB} = 24 \left[\frac{20}{20 + 4} \right]$$

$$V_{AB} = 20\text{ V}$$

Problem 4.70

Find R_L for maximum power transfer and the maximum power that can be transferred in the network shown.

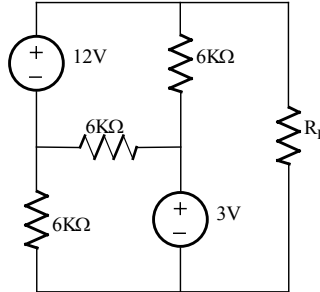

Suggested Solution

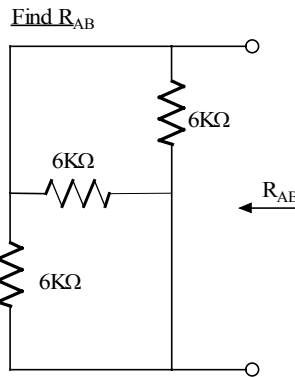
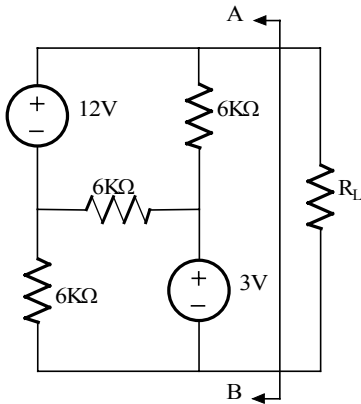

All 3 Resistors are attached to both node A and node B, so,

$$R_{AB} = 6K \parallel 6K \parallel 6K$$

$$R_{AB} = 2K\Omega$$

Find maximum load transfer

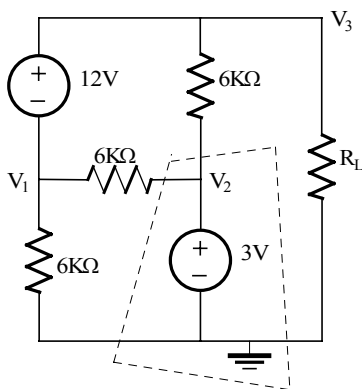

$$V_3 - V_1 = 12V$$

$$V_2 = 3V$$

At supernode:

$$(V_3 - V_2) / 6K + (V_1 - V_2) / 6K + V_3 / 2K + V_1 / 6K = 0$$

Yields:

$$V_3 = 5V$$

$$P_L = V_3^2 / R_{AB}$$

$$P_L = 12.5 \text{ mW}$$

Problem 4.71

Find R_L for maximum power transfer and the maximum power that can be transferred in the network shown.

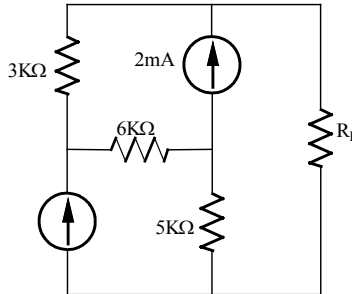

Suggested Solution

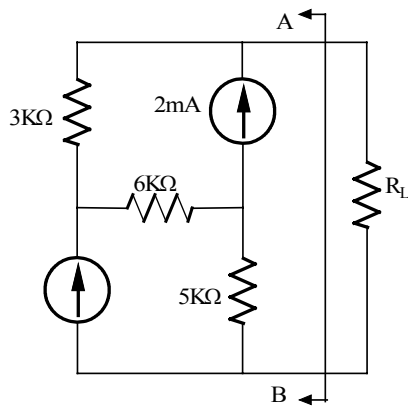

Find R_{AB}

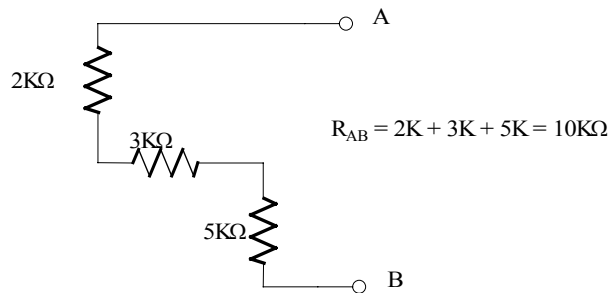

Find maximum load transfer

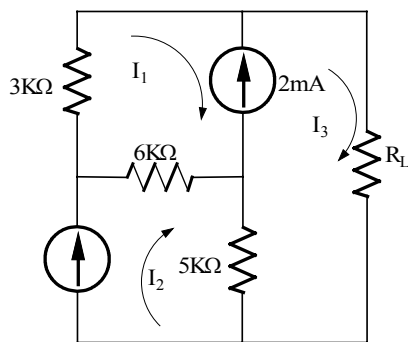

$$I_3 - I_1 = 2\text{mA} \quad I_2 = 1\text{mA}$$

$$(2K) I_1 + (10K) I_3 + 5K(I_3 - I_2) + 3K(I_1 - I_2) = 0$$

yields: $I_3 = 0.9\text{mA}$

$$P_L = I_3^2 R_{AB}$$

$P_L = 8.1 \text{ mW}$

Problem 4.72

In the network shown find R_L for maximum power transfer and the maximum power that can be transferred to this load.

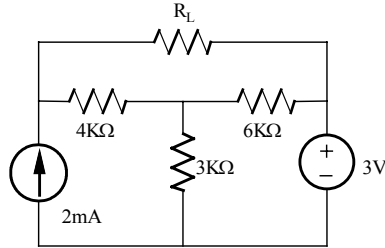

Suggested Solution

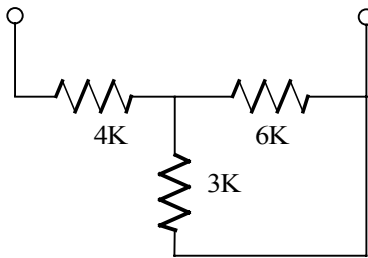

$$R_{th} = 4K + 3K \parallel 6K = 6K\Omega$$

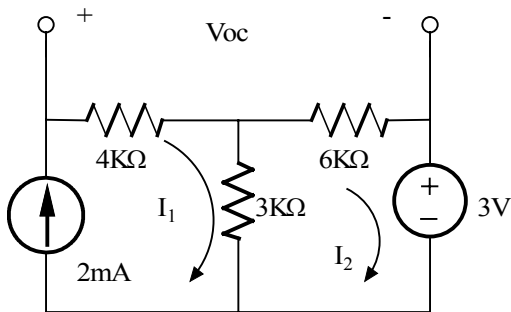

$$I_1 = 2m$$

$$3K(I_2 - I_1) + 6K I_2 + 3 = 0$$

$$I_2 = 1/3 \text{ mA}$$

$$V_{oc} = 4K(2m) + 6K(1/3 \text{ m}) = 10V$$

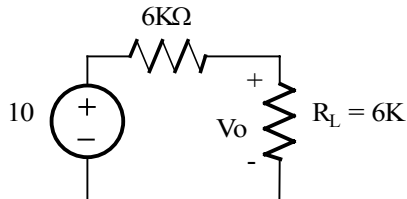

$V_o = 5V$

$$P_L = V_o^2 / R_L$$

$P_L = 25/6 \text{ mW}$

Problem 4.73

Find R_L for maximum power transfer and the maximum power that can be transferred in the network shown.

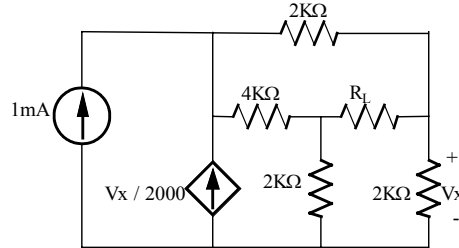

Suggested Solution

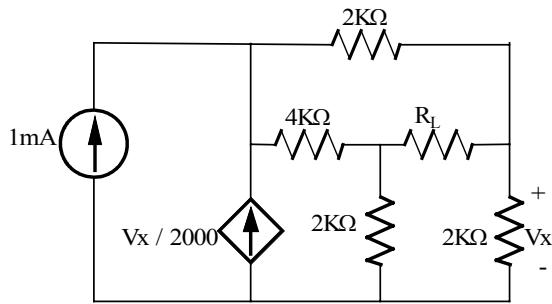

To find R_{eq} , replace R_L with a 1mA current source,
 $R_{eq} = V_{T_{est}} / 1mA$

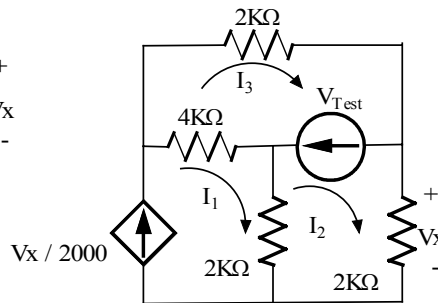

Find max load power

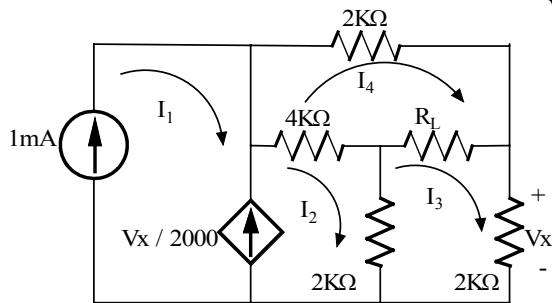

$$\begin{aligned}
 I_1 &= V_x / 2K, \quad I_2 = V_x / 2K \\
 I_3 - I_2 &= 1mA \\
 (2K)I_3 + (2K)I_2 + 2K(I_2 - I_1) + 4K(I_3 - I_1) &= 0 \\
 V_{T_{est}} &= 4K(I_3 - I_1) + (2K)I_3 \\
 \text{yields: } V_{T_{est}} &= 3V \\
 R_{eq} &= V_{T_{est}} / 1mA = 3K
 \end{aligned}$$

$$\begin{aligned}
 I_1 &= 1mA, \quad I_2 - I_1 = V_x / 2K, \quad I_3 = V_x / 2K \\
 4K(I_4 - I_2) + 2K I_4 + 3K(I_4 - I_3) &= 0 \\
 2K I_3 + 2K(I_3 - I_2) + 3K(I_3 - I_4) &= 0
 \end{aligned}$$

yields: $I_3 = 1.25mA$ and $I_4 = 1.42mA \Rightarrow P_L = 3K(I_4 - I_3)^2$

$P_L = 83.3 \mu W$

Problem 4.74

In the network shown find I_o using PSPICE.

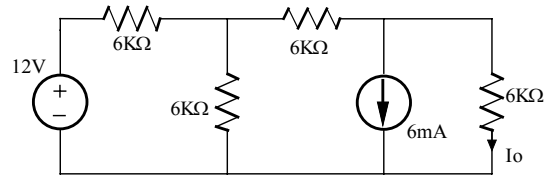

Suggested Solution

$I_o = 3.2 \text{ mA}$.

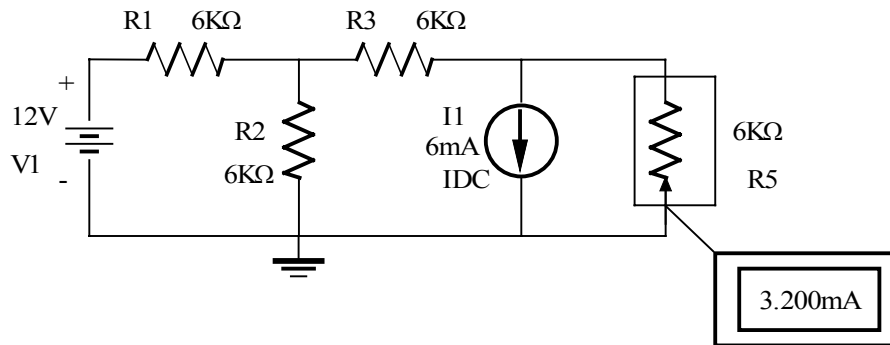

Problem 4.75

In the network shown determine V_o using PSPICE.

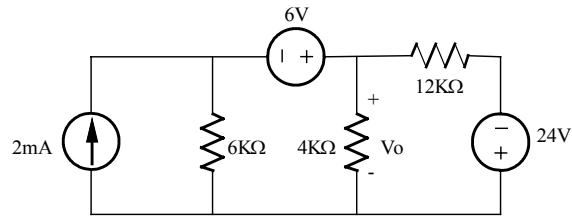

Suggested Solution

$V_o = 2V$

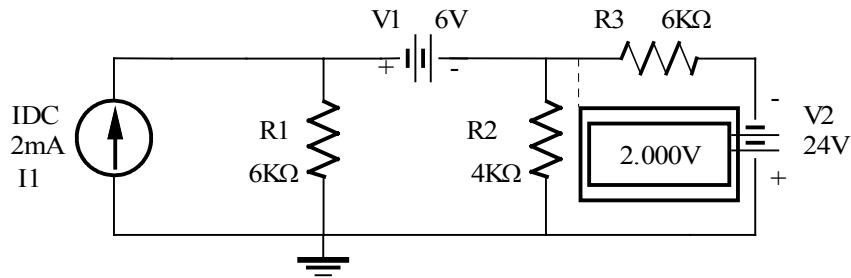

Problem 4.76

Find V_o in the network shown using PSPICE.

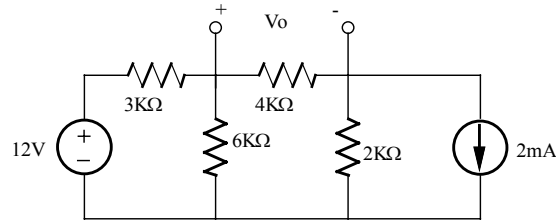

Suggested Solution

$$V_o = 5 - (-1) = 6 \text{ V.}$$

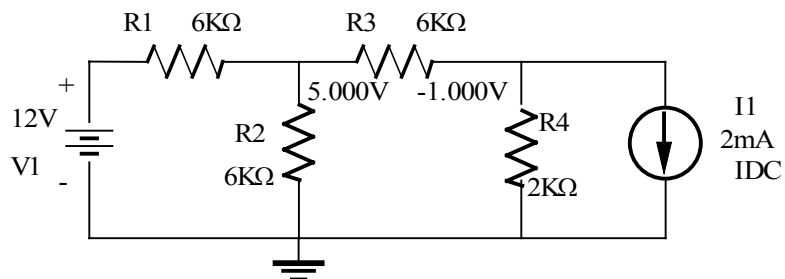

Problem 4.77

Find V_o in the network shown using PSPICE.

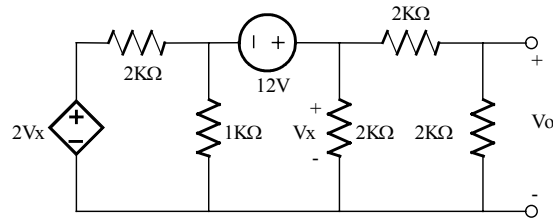

Suggested Solution

$$V_o = 8\text{V}$$

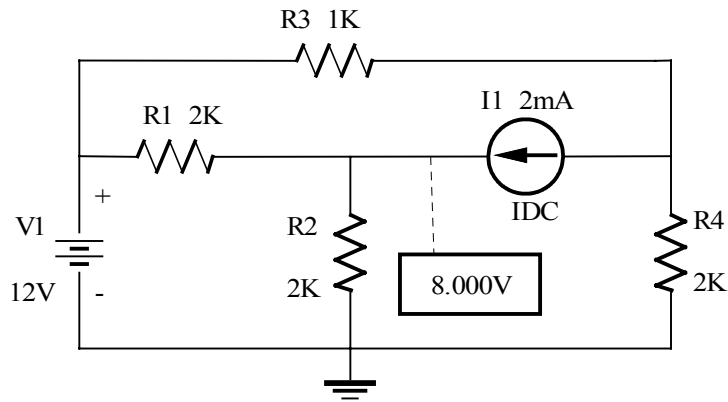

Problem 4FE-1

Determine the maximum power that can be delivered to the load R_L in the network shown.

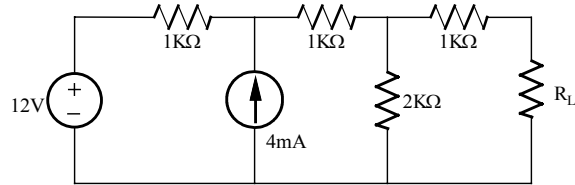

Suggested Solution

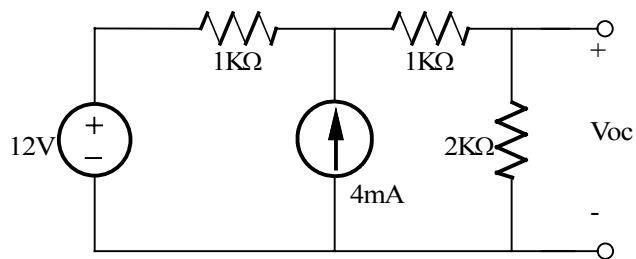

$$\begin{aligned} (V_x - 12) / 1K - 4m + V_x / 3K &= 0 \\ V_x &= 12V \\ V_{oc} &= V_x [2K / (2K + 1K)] = 8V \end{aligned}$$

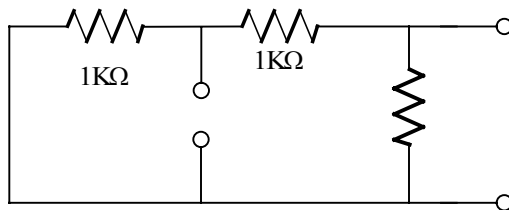

$$R_{th} = 2K \parallel 2K = 1K$$

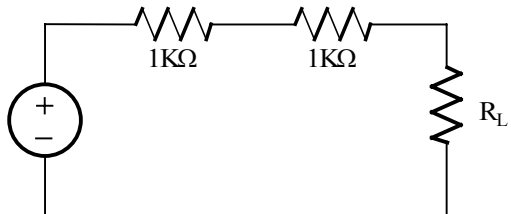

$$R_L = 2K$$

$$P_{RL} = (8 / 4K)^2 (2K)$$

$$P_{RL} = 8mW$$

Problem 4FE-2

Find the value of the load R_L in the network shown that will achieve maximum power transfer, and determine the value of the maximum power.

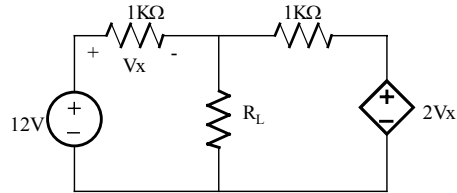

Suggested Solution

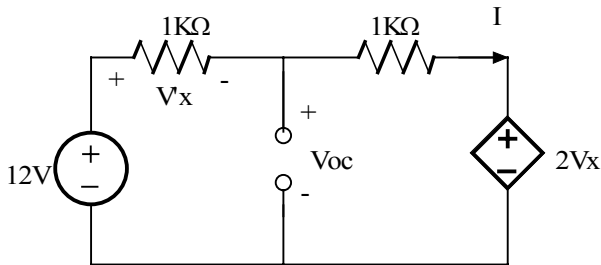

$$-12 + 2KI + 1KI + 2V_x = 0$$

$$V_x = 2KI$$

$$V_{oc} = 12 - 2KI = 66/7 \text{ V}$$

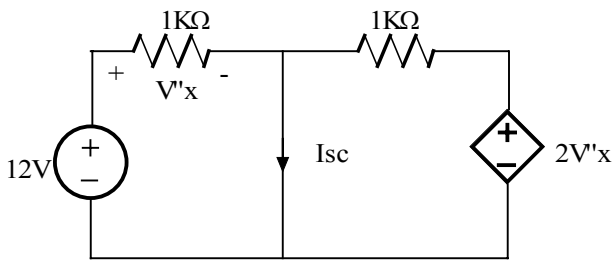

$$V_x = 12$$

$$I_{sc} = 12 / 2K + 24 / 1K = 30\text{mA}$$

$$R_{th} = V_{oc} / I_{sc} = 2/7 \text{ K}$$

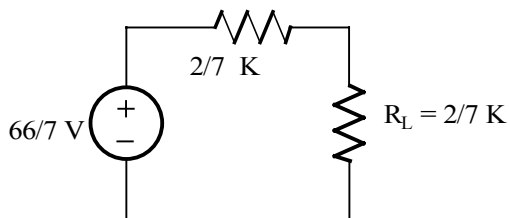

$$P = [(60/7)/(4/7 \text{ K})]^2 (2/7 \text{ K})$$

$$P = 64.3 \text{ mW}$$

Problem 4FE-3

Find the value of R_L in the network shown for maximum power transfer to this load.

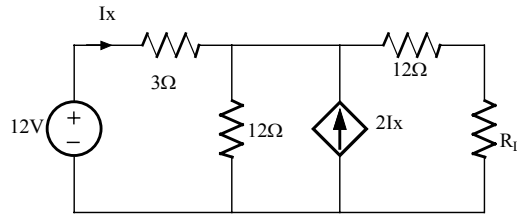

Suggested Solution

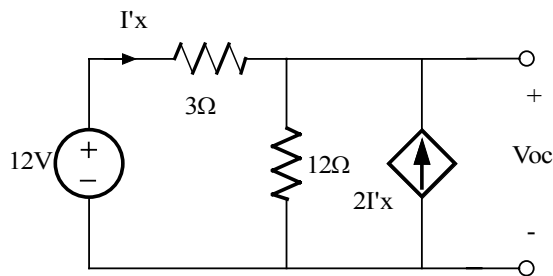

$$\begin{aligned} (V_{oc} - 12) / 3 + V_{oc} / 12 - 2 I'x &= 0 \\ I'x &= (12 - V_{oc}) / 3 \\ V_{oc} &= 144/13 \text{ V} \end{aligned}$$

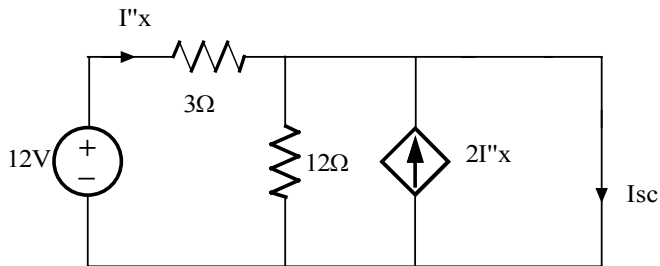

$$I''x = 12/3 = 4\text{mA}$$

Then

$$I_{sc} = I''x + 2I''x = 12\text{A}$$

$$R_{th} = V_{oc} / I_{sc} = (144/13)/12 = 12/13 \Omega$$

Then $R_L = 12 + 12/13$

$R_L = 12.92\Omega \text{ for MPT}$

Problem 5.1

A $12\mu\text{F}$ capacitor has an accumulated charge of $480\mu\text{C}$. Determine the voltage across the capacitor after 4 s.

Suggested Solution

$$v(t_2) - v(t_1) = \frac{1}{C} \int_{t_1}^{t_2} i(t) dt \quad C = 100\mu\text{F} \quad i(t) = 1\text{mA} = I$$

$$v(t_1) = 0. \quad \text{so,} \quad v(t_2) = \frac{1}{C} (t_2 - t_1) \quad \text{where} \quad t_2 - t_1 = 4\text{sec}$$

$$v(t_2) = 40V$$

Problem 5.2

A $12\mu\text{F}$ capacitor has an accumulated charge of $480\mu\text{C}$. Determine the voltage across the capacitor.

Suggested Solution

$$C = \frac{Q}{V} \quad Q = 480\mu\text{C} \quad \boxed{C = 12\mu\text{F}} \quad \boxed{V = 40\text{V}}$$

Problem 5.3

A capacitor has an accumulated charge of $600\mu\text{C}$ with 5V across it. What is the value of capacitance?

Suggested Solution

$$C = \frac{Q}{V} \quad Q = 600\mu\text{C} \quad V = 5\text{V} \quad C = 120\mu\text{F}$$

Problem 5.4

A $25\text{-}\mu\text{F}$ capacitor initially charged to -10V is charged by a constant current of $2.5\ \mu\text{A}$. Find the voltage across the capacitor after $2\ \frac{1}{2}$ minutes.

Suggested Solution

$$\begin{aligned} V &= \frac{1}{C} \int_0^t i dt + v(0) \\ &= \frac{1}{25 \times 10^{-6}} \int_0^{150} 2.5 \times 10^{-6} dt - 10 \\ &= \frac{1}{10} \int_0^{150} dt - 10 = \frac{1}{10} t \Big|_0^{150} - 10 \end{aligned}$$

$$\boxed{V = 15 - 10 = 5V}$$

Problem 5.5

The energy that is stored in a 25- μ F capacitor is $w(t)=12\sin^2 377t$ J. Find the current in the capacitor.

Suggested Solution

$$w(t) = \frac{1}{2} C v^2(t) = 12 \sin^2 377t$$

$$C = 25 \mu\text{F} \quad \Rightarrow \quad v^2(t) = \frac{2(12)}{25 \times 10^{-6}} \sin^2 377t = 9.6 \times 10^5 \sin^2 377t$$

$$v(t) = \pm 979.8 \sin 377t \text{ V}$$

$$i(t) = C \frac{dv(t)}{dt} = \pm 25 \times 10^{-6} (979.8)(377) \cos 377t = \pm 9.23 \cos 377t \text{ A}$$

Problem 5.6

An uncharged 10- μ F capacitor is charged by the current $I(t)=10\cos 377t$ mA. Find (a) the expression for the voltage across the capacitor and (b) the expression for the power.

Suggested Solution

$$i(t) = 10 \cos(377t) \text{ mA} \quad C = 10 \mu\text{F} \quad v(0) = 0 \text{ V}$$

a)

$$v(t) = \frac{1}{C} \int_0^t i(t) dt = \frac{0.01}{C} \frac{1}{377} \sin(377t) \Big|_0^t$$

$$v(t) = 2.65 \sin(377t) \text{ V}$$

b)

$$P(t) = v(t)i(t) = (2.65)(0.01) \sin(377t) \cos(377t)$$

$$\text{but } \cos(x) \sin(x) = \frac{1}{2} \sin(2x) \quad \text{so,}$$

$$p(t) = 13.3 \sin(754t) \text{ mW}$$

Problem 5.7

The voltage across a 100- μ F capacitor is given by the expression $v(t)=120\sin(377t)$ V. Find (a) the current in the capacitor and (b) the expression for the energy stored in the element.

Suggested Solution

$$v(t) = 120 \sin(377t) \text{ V}, \quad C = 100 \mu\text{F}$$

$$a) \quad i(t) = C \frac{dv}{dt} = (100 \times 10^{-6})(120)(377) \cos(377t) = 4.52 \cos(377t) \text{ A}$$

$$\begin{aligned} b) \quad w(t) &= \frac{1}{2} C v^2(t) = \frac{1}{2} (10^{-4}) (120)^2 \sin^2(377t) \\ &= 720 \sin^2(377t) \text{ mJ} \\ &= 360 - 360 \cos 754t \text{ mJ} \end{aligned}$$

Problem 5.8

A capacitor is charged by a constant current of 2mA and results in a voltage increase of 12V in a 10-s interval. What is the value of the capacitance?

Suggested Solution

$$v(t_2) - v(t_1) = \frac{1}{C} \int_{t_1}^{t_2} i(t) dt \quad i(t) = 2mA = I$$

$$v(t_2) - v(t_1) = 12 = \frac{I}{C} (t_2 - t_1) = \frac{I}{C} (10)$$

$$C = (2m)(10) / 12 = 1.67mF$$

$$\boxed{C = 1.67mF}$$

Problem 5.9

The current in a $100\mu\text{F}$ capacitor is shown in Figure P5.9. Determine the waveform for the voltage across the capacitor if it is initially uncharged.

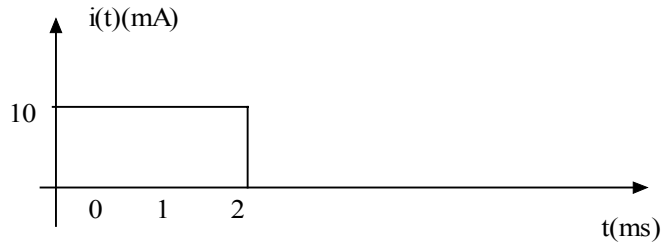
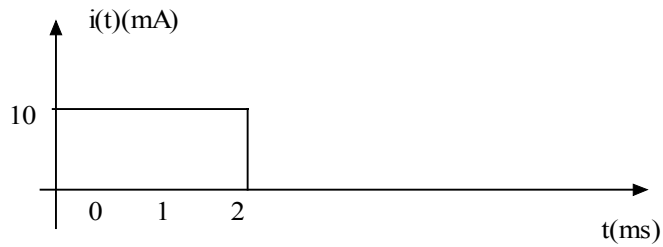

Figure P5.9

Suggested Solution

$$C = 100\mu\text{F} \quad v(t) = \frac{1}{C} \int i(t) dt$$

Time (ms)	$i(t)$ (mA)	$v(t)$ (V)
$0 \leq t \leq 2$	10	$100t$
$t > 2$	0	$0 + v(2\text{ms}) = 0.2\text{V}$



Problem 5.10

The voltage across a $100\text{-}\mu\text{F}$ capacitor is shown in Figure P5.10. Compute the waveform for the current in the capacitor

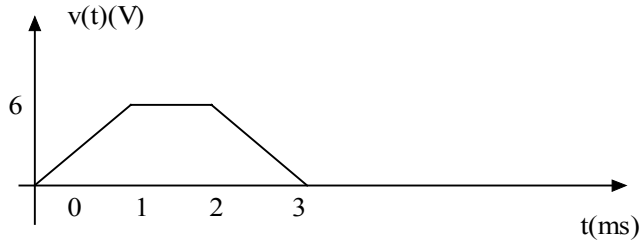

Figure P5.10

Suggested Solution

$$C = 100\mu\text{F} \quad i(t) = Cc$$

Time (ms)	$\frac{dv}{dt}(\text{V/ms})$	$i(t)$ (mA)
$0 \leq t \leq 1$	6	600
$1 \leq t \leq 2$	0	0
$2 \leq t \leq 3$	-6	-600

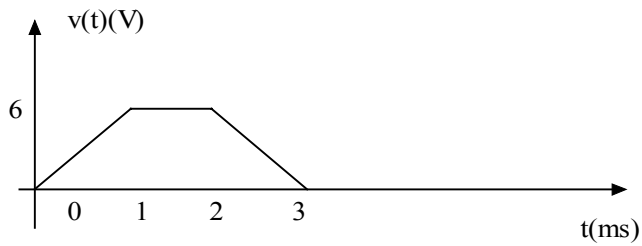

Figure P5.10

Problem 5.11

The voltage across a $6\mu\text{F}$ capacitor is shown in Figure P5.11. Compute the waveform for the current in the capacitor

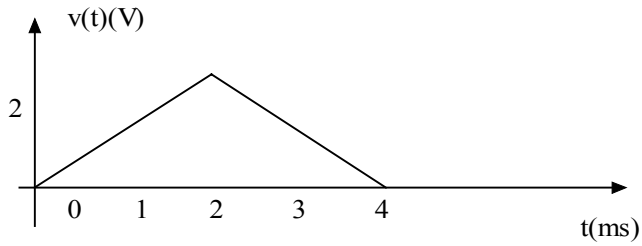
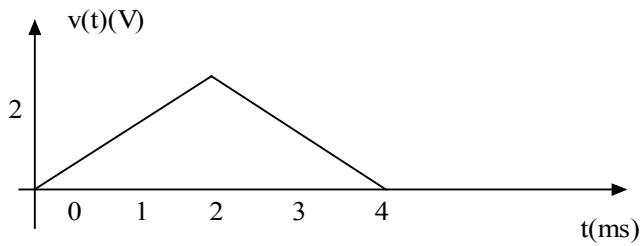

Figure P5.11

Suggested Solution

$$C = 6\mu\text{F} \quad i(t) = C \frac{dv(t)}{dt}$$

Time (ms)	$\frac{dv}{dt}(\text{V/ms})$	$i(t)$ (mA)
$0 \leq t \leq 2$	61	6
$2 \leq t \leq 4$	-1	-6



Problem 5.12

The voltage across a $50\text{-}\mu\text{F}$ capacitor is shown in Figure P5.12. Determine the current waveform.

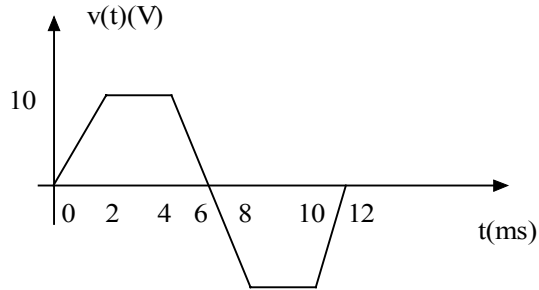

Figure P5.12

Suggested Solution

$$C = 50\mu\text{F}$$

$$i(t) = C \frac{dv}{dt}$$

Time (ms)	$\frac{dv}{dt}$ (V/ms)	$i(t)$ (mA)
$0 \leq t \leq 2$	5	250
$2 \leq t \leq 4$	0	0
$4 \leq t \leq 8$	-5	-250
$8 \leq t \leq 10$	0	0
$10 \leq t \leq 12$	5	250
$t > 12$	0	0

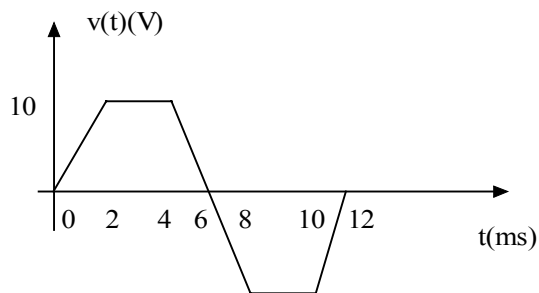

Problem 5.13

The voltage across a $2\text{-}\mu\text{F}$ capacitor is given by the waveform in Figure P5.13. Compute the current waveform.

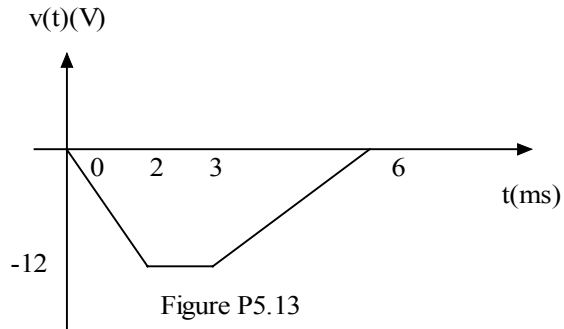

Suggested Solution

$$C = 2\mu\text{F}$$

$$i(t) = C \frac{dv}{dt}$$

Time (ms)	$\frac{dv}{dt}$ (V/ms)	$i(t)$ (mA)
$0 \leq t \leq 2$	-6	-12
$2 \leq t \leq 3$	0	0
$3 \leq t \leq 6$	4	8
$t > 6$	0	0

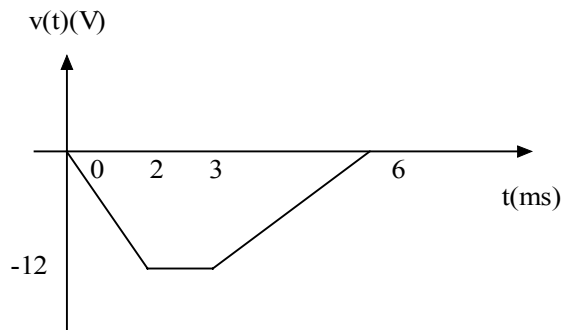

Problem 5.14

The voltage across a 0.1-F capacitor is given by the waveform in Figure P5.14. Find the waveform for the current in the capacitor

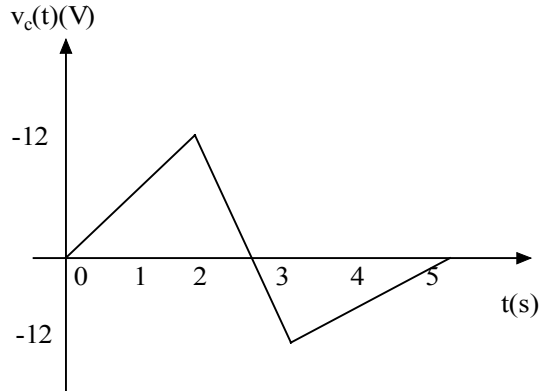

Figure P5.14

Suggested Solution

$$C = 0.1F$$

$$i(t) = C \frac{dv}{dt}$$

Time (s)	$\frac{dv}{dt}$ (V/ms)	$i(t)$ (A)
$0 \leq t \leq 2$	6	0.6
$2 \leq t \leq 3$	-24	-2.4
$3 \leq t \leq 5$	6	0.6
$t > 5$	0	0

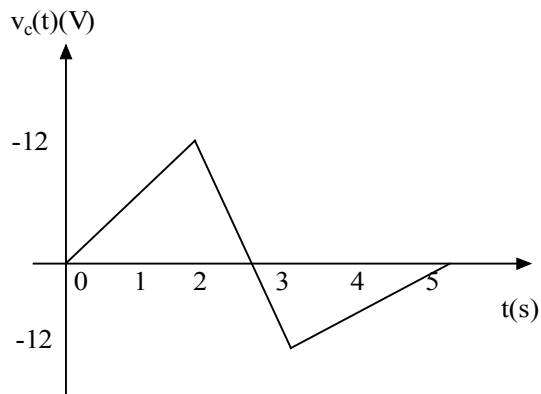

Problem 5.15

The waveform for the current in a 200- μF capacitor is shown in Figure P5.15. Determine the waveform for the capacitor voltage.

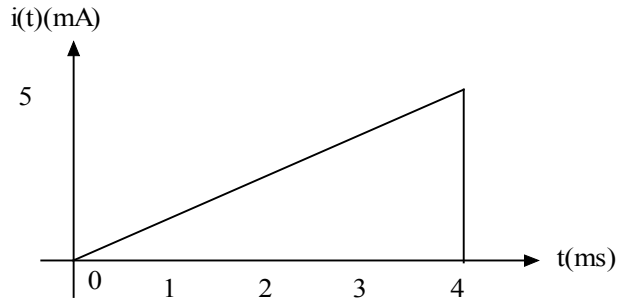

Figure P5.15

Suggested Solution

$$C = 200\mu\text{F} \quad v(t) = \frac{1}{C} \int i(t) dt$$

$$0 \leq t \leq 4\text{ms}$$

$$i(t) = 1.25t \text{ A}$$

$$v(t) = 3125t^2 + v(0)$$

$$\text{assuming } v(0) = 0\text{V},$$

$$v(t) = 3125t^2$$

$$t > 4\text{ms}$$

$$i(t) = 0\text{A}$$

$$v(t) = 0 + v(4\text{ms})$$

$$v(t) = 0 + 3125(4\text{ms})^2 = 50\text{mV}$$

$$v(t) = \begin{cases} 3125t^2\text{V} & 0 \leq t \leq 4\text{ms} \\ 50\text{mV} & t > 4\text{ms} \end{cases}$$

Problem 5.16

Draw the waveform for the current in a $12\text{-}\mu\text{F}$ capacitor when the capacitor voltage is as described in Figure 5.16

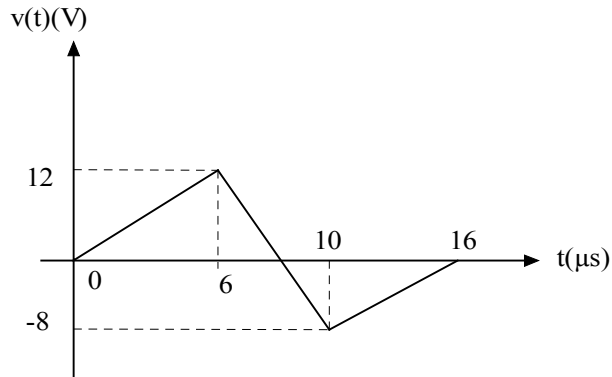
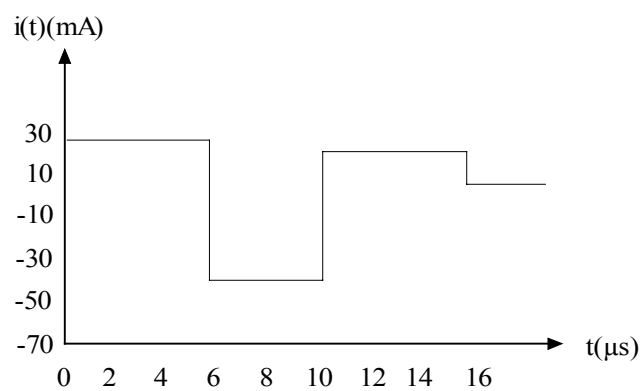
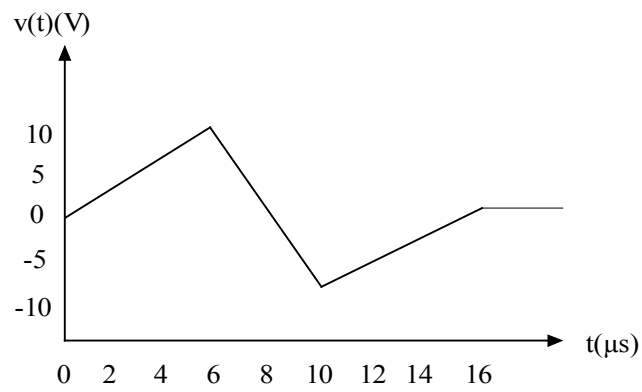
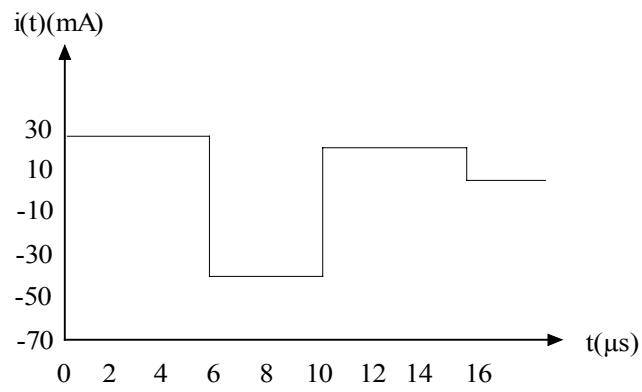
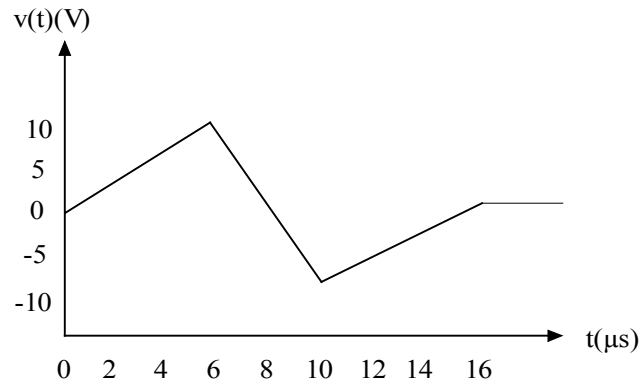

Figure P5.16

Suggested Solution

$$C = 12\mu\text{F} \quad i(t) = C \frac{dv}{dt}$$

Time (μs)	$\frac{dv}{dt}(\text{V}/\mu\text{s})$	$i(t)$ (A)
$0 \leq t$	2	24
$6 \leq t \leq 10$	-5	-60
$10 \leq t \leq 16$	1.33	16
$t > 16$	0	0



Problem 5.17

Draw the waveform for the current in a $3\text{-}\mu\text{F}$ capacitor when the voltage across the capacitor is given in Figure P5.17

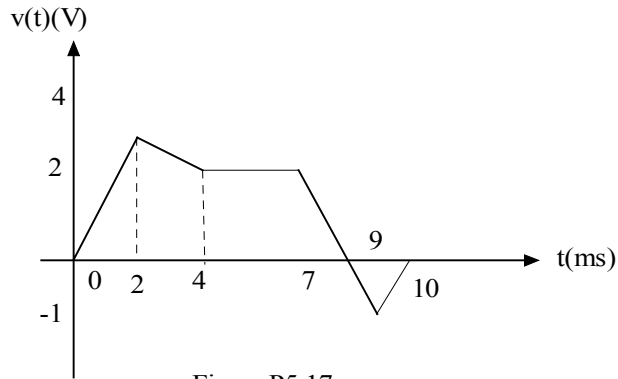

Suggested Solution

$$C = 3\mu\text{F}$$

$$i(t) = C \frac{dv}{dt}$$

Time (ms)	$\frac{dv}{dt} (\text{V}/\mu\text{s})$	$i(t)$ (A)
$0 \leq t \leq 2$	2	6
$2 \leq t \leq 4$	-1	-3
$4 \leq t \leq 7$	0	0
$7 \leq t \leq 9$	$-\frac{3}{2}$	-4.5
$9 \leq t \leq 10$	1	3
$t > 0$	0	0

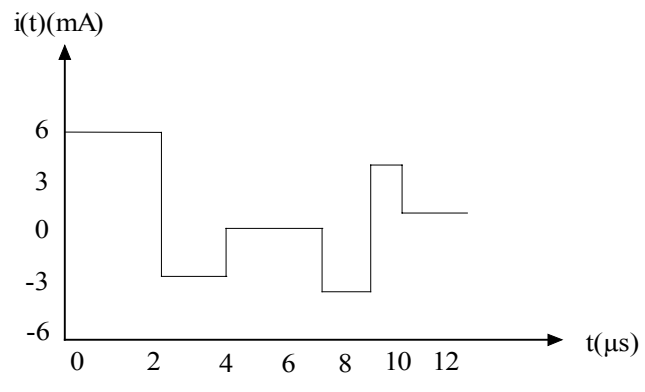
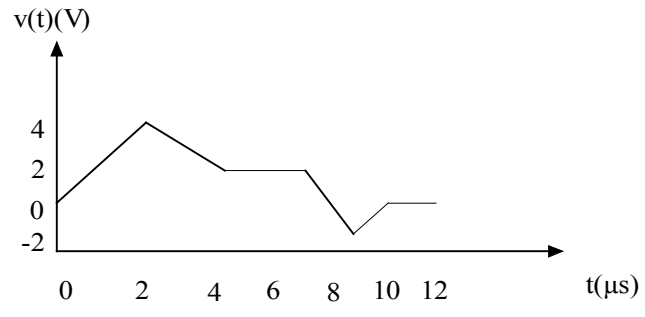

Problem 5.18

The waveform for the current in a $100\text{-}\mu\text{F}$ initially uncharged capacitor is shown in Figure P5.18. Determine the waveform for the capacitor's voltage.

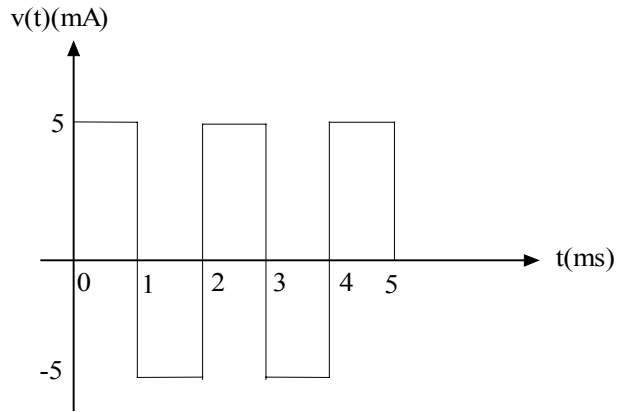
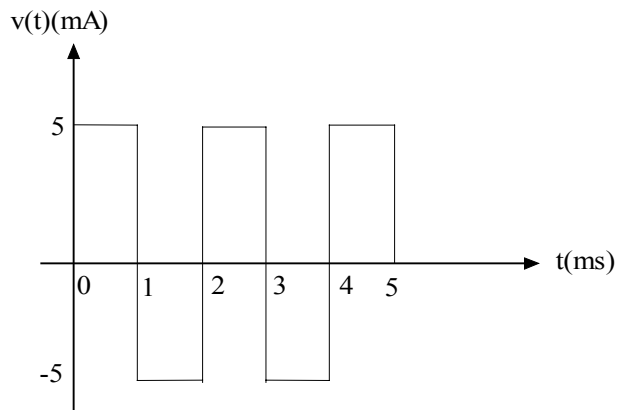

Figure P5.18

Suggested Solution



$$C = 100\mu F \quad v(t) = \frac{1}{C} \int i(t) dt$$

$$v(0) = 0V$$

$$0 \leq t \leq 1ms \quad i(t) = -5mA$$

$$v(t) = 50t \quad \nabla$$

$$1ms \leq t \leq 2ms \quad i(t) = -5mA$$

$$v(t) = -50(t - 1m) + v(1m)$$

$$v(t) = -50t + 0.1 \quad \nabla$$

$$2ms \leq t \leq 3ms \quad i(t) = 5mA$$

$$v(t) = 50(t + 2m) + v(2m)$$

$$v(t) = 50t - 0.1 \quad \nabla$$

$$3ms \leq t \leq 4ms \quad i(t) = -5mA$$

$$v(t) = -50(t - 3m) + v(3m)$$

$$v(t) = -50t + 0.2 \quad \nabla$$

$$4ms \leq t \leq 5ms \quad i(t) = 5mA$$

$$v(t) = 50(t - 4m) + v(4m)$$

$$v(t) = 50t - 0.2 \quad \nabla$$

$$t > 5ms \quad i(t) = 0$$

$$v(t) = 50mV$$

$v(t) =$	{	$50t$	∇	$0 \leq t \leq 1ms$
		$-50t + 0.1$	∇	$1ms \leq t \leq 2ms$
		$50t - 0.1$	∇	$2ms \leq t \leq 3ms$
		$-50t + 0.2$	∇	$3ms \leq t \leq 4ms$
		$50t - 0.2$	∇	$4ms \leq t \leq 5ms$
		50	mV	$t > 5ms$

Problem 5.19

The voltage across a $6\text{-}\mu\text{F}$ capacitor is given by the waveform in Figure P5.19. Plot the waveform for the capacitor current.

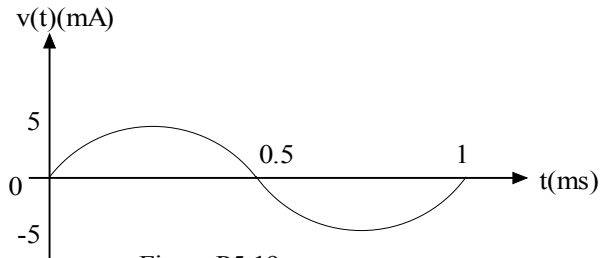

Figure P5.19

Suggested Solution

$$C = 6\mu\text{F} \quad i(t) = C \frac{dv}{dt}$$

$$\text{if } v(t) = 10 \sin(\omega t) \text{ V}$$

$$\omega = 2\pi f = 2\pi / T \quad \text{where } T = 1 \text{ m sec,}$$

$$v(t) = 10 \sin(2000\pi t) \text{ V}$$

$$i(t) = (6\mu)(10)(2000\pi) \cos(2000\pi t)$$

$$\boxed{i(t) = 377 \cos(2000\pi t) \text{ mA}}$$

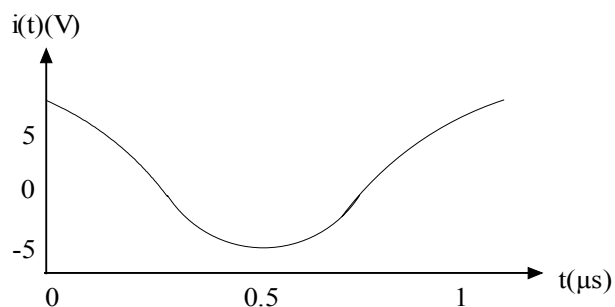
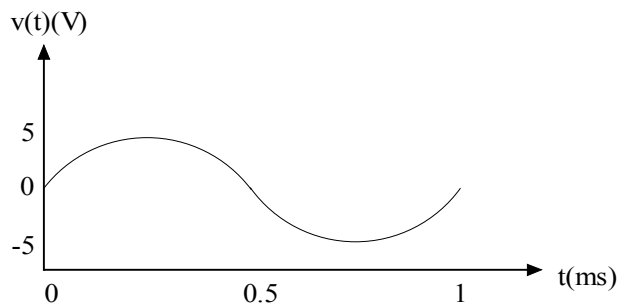

Problem 5.20

The current in an inductor changes from 0 to 200mA in 4ms in 4 ms and induces a voltage of 100mV. What is the value of the inductor?

Suggested Solution

$$v(t) = L \frac{di}{dt}$$

$$\Delta i = 200mA \quad \Delta t = 4ms \quad v_{ind} = 100mV$$

Assuming the current change is linear,

$$v_{ind} = L \frac{\Delta i}{\Delta t} \Rightarrow L = v_{ind} \left(\frac{\Delta t}{\Delta i} \right) = 2mH$$

$$\boxed{L = 2mH}$$

Problem 5.21

The current in a 100-mH inductor is $i(t)=2\sin(377t)$ A. Find (a) the voltage across the inductor and (b) the expression for the energy stored in the element

Suggested Solution

$$L = 100\text{mH} \quad i(t) = 2\sin(377t)\text{A}$$

a)

$$v(t) = L \frac{di}{dt} = (0.1)(2)(377)\cos(377t) = \boxed{75.4\cos(377t)\text{V}}$$

b)

$$w(t) = \frac{1}{2}i^2(t) = \frac{0.1}{2}(2)^2\sin^2(377t) = 0.2\sin^2(377t)$$

but $\sin^2 x = \frac{1}{2} - \frac{1}{2}\cos(2x)$ so

$$\boxed{w(t) = 0.1 - 0.1\cos(754t) \text{ J}}$$

Problem 5.22

A 10-mH inductor has a sudden current change from 200mA to 100mA in 1ms. Find the induced voltage.

Suggested Solution

$$L = 10\text{mH} \quad \Delta i = 100\text{mA} - 200\text{mA} = -100\text{mA} \quad \Delta t = 1\text{ms}$$

$$v(t) = L \frac{di}{dt} \quad \text{assuming the current changed linearly}$$

$$v_{IND} = (0.01) \frac{\Delta i}{\Delta t} = -1\text{V}$$

$$\boxed{v_{IND} = -1\text{V}}$$

Problem 5.23

The induced voltage across a 10-mH inductor is $v(t)=120\cos(377t)$ V. Find (a) the expression for the inductor current and (b) the expression for the power.

Suggested Solution

$$L = 10\text{mH} \quad v(t) = 120\cos(377t)\text{V} \quad \text{Assume } i(0) = 0.$$

a)

$$i(t) = \frac{1}{L} \int v(t) dt = \frac{120}{0.01} \frac{1}{377} \sin(377t) = \boxed{31.83 \sin(377t) \text{A}}$$

b)

$$p(t) = v(t)i(t) = (120)(31.83) \cos(377t) \sin(377t)$$

$$\text{but } \sin(x)\cos(x) = \frac{1}{2}\sin(2x) \quad \text{so,}$$

$$\boxed{p(t) = 1910 \sin(754t) \text{W}}$$

Problem 5.24

The current in a 25-mH inductor is given by the expressions

$$\begin{aligned} i(t) &= 0 & t < 0 \\ i(t) &= 10(1 - te^{-4t}) \text{ mA} & t > 0 \end{aligned}$$

Find (a) the voltage across the inductor, (b) the expression for the energy stored in it.

Suggested Solution

$$L = 25 \text{ mH}$$

$$a) \quad i(t) = \begin{cases} 0 & t < 0 \\ 10(1 - e^{-t}) \text{ mA} & t > 0 \end{cases}$$

$$v(t) = L \frac{di}{dt}$$

$$t < 0: \quad v(t) = 0$$

$$t > 0: \quad v(t) = (0.025)(0.01)e^{-t} = 250e^{-t} \mu\text{V}$$

$$v(t) = \begin{cases} 0 & t < 0 \\ 250e^{-t} \mu\text{V} & t > 0 \end{cases}$$

b)

$$w(t) = \frac{1}{2} i^2(t) = 1.25[1 - 2e^{-t} + e^{-2t}] \mu\text{J}$$

Problem 5.25

Given the data in the previous problem, find the voltage across the inductor and the energy stored in it after 1 s.

Suggested Solution

$$v(t) = 250e^{-t} \mu V \quad w(t) = 1.25[1 - 2e^{-t} + e^{-2t}] \mu J$$

$$\text{at } t = 1 \text{ sec.} \quad \boxed{v(1) = 91.97 \mu V \quad w(1) = 0.5 \mu J}$$

Problem 5.26

The current in a 50-mH inductor is given by the expressions

$$\begin{aligned} i(t) &= 0 & t < 0 \\ i(t) &= 2te^{-4t} \text{ A} & t > 0 \end{aligned}$$

Find (a) the voltage across the inductor, (b) the time at which the current is a maximum, and (c) the time at which the voltage is a minimum

Suggested Solution

$$L = 50 \text{ mH} \quad i(t) = \begin{cases} 0 & t < 0 \\ 2te^{-4t} \text{ A} & t > 0 \end{cases}$$

$$a) \quad v(t) = L \frac{di(t)}{dt} = (0.05)(2e^{-4t} - 8te^{-4t}) \quad \text{for } t > 0$$

$$v(t) = \begin{cases} 0 & t < 0 \\ 0.1e^{-4t}(1-4t) \text{ V} & t > 0 \end{cases}$$

b)

The current will be at its maximum when $di/dt = 0$, or, $v(t) = 0$

$$v(t_{\max}) = 0 = 0.1e^{-4t_{\max}}(1-4t_{\max}) \rightarrow t_{\max} = 0.25 \text{ sec}$$

c)

The voltage will be at its max. or min. when $dv/dt = 0$

$$\frac{dv}{dt} \Big|_{t=t_{\min}} = [0.1e^{-4t}(-4) + 0.1e^{-4t}(4)(4t-1)] \Big|_{t=t_{\min}} = 0$$

$$\text{yields: } \boxed{t_{\min} = 0.5 \text{ sec.}}$$

Problem 5.27

The current

$$\begin{array}{ll} i(t) = 0 & t < 0 \\ i(t) = 100te^{-t/10} \text{ A} & t > 0 \end{array}$$

flows through a 150-mH inductor. Find both the voltage across the inductor and the energy stored in it after 5 seconds.

Suggested Solution

$$v(t) = L \frac{di}{dt}$$

$$v(t) = 100 \times 10^{-3} \frac{d}{dt} (100e^{-t/10})$$

$$v(t) = \frac{100}{1000} \left(\frac{100}{10} \right) (-e^{-t/10})$$

$$v(t) = -1.5e^{-t/10}$$

$$v(5) = -1.5e^{-1/2} = -0.91V$$

$$w(t) = \frac{1}{2} Li^2$$

$$w(t) = \frac{1}{2} (50 \times 10^{-3}) (10^4 e^{-\frac{2t}{10}})$$

$$w(t) = \frac{1}{2} (50)(10)e^{-\frac{t}{5}}$$

$$w(t) = 250e^{-\frac{t}{5}}$$

$$w(5) = 91.97J$$

Problem 5.28

The current in a 10-mH inductor is shown in Figure P5.28. Find the voltage across the inductor.

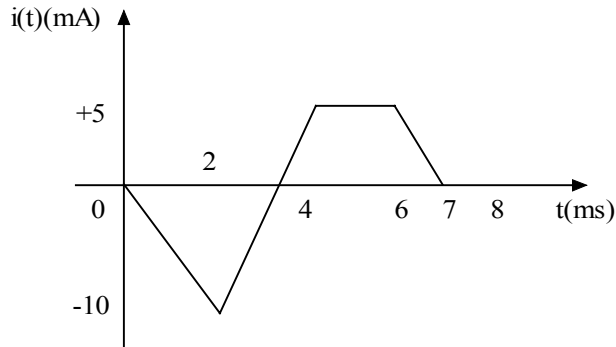

Figure P5.28

Suggested Solution

$$L = 10\text{mH}$$

$$v(t) = C \frac{di}{dt}$$

Time (ms)	$\frac{di}{dt}$ (A/ms)	$v(t)$ (mV)
$0 \leq t \leq 2$	-5	-50
$2 \leq t \leq 4$	7.5	75
$4 \leq t \leq 6$	0	0
$6 \leq t \leq 7$	-5	-50
$t > 7$	0	0

Problem 5.29

The current in a 50-mH inductor is given in Figure P5.29. Sketch the inductor voltage.

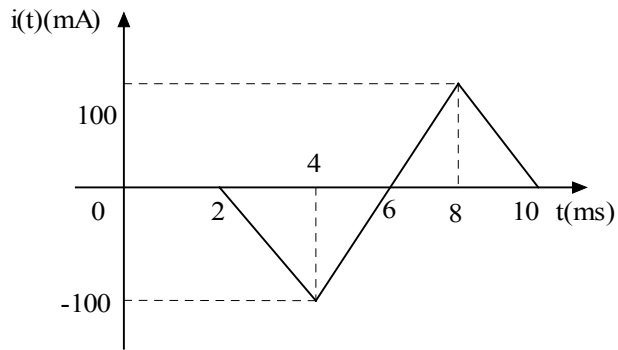

Figure P5.29

Suggested Solution

$$L = 50\text{mH}$$

$$v(t) = L \frac{di}{dt}$$

Time (ms)	$\frac{di}{dt}$ (A/s)	$v(t)$ (V)
$0 \leq t \leq 2$	0	0
$2 \leq t \leq 4$	-50	-2.5
$4 \leq t \leq 8$	50	2.5
$8 \leq t \leq 10$	-50	-2.5
$t > 10$	0	0

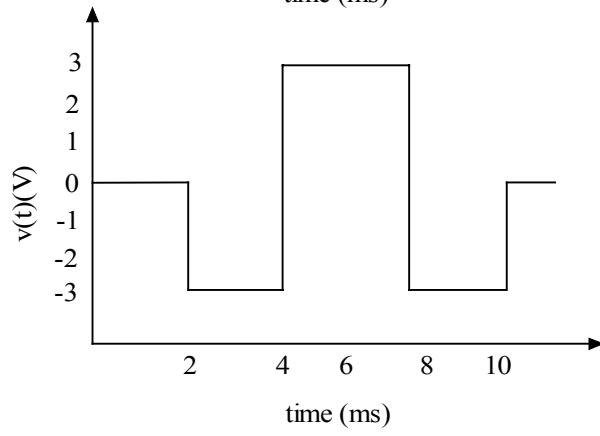
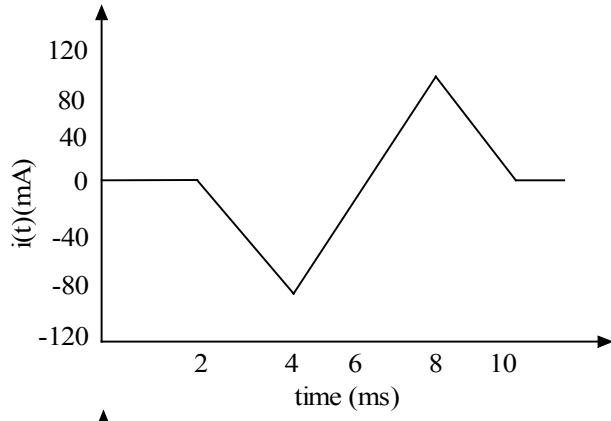

Problem 5.30

The current in a 16-mH inductor is given by the waveform in Figure P5.30. Find the waveform of the voltage across the inductor.

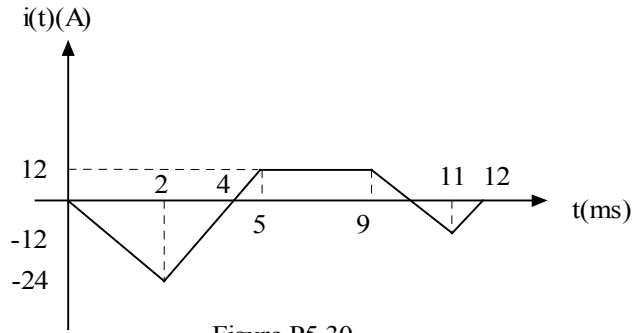

Suggested Solution

$L = 16\text{mH}$	$v(t) = L \frac{di}{dt}$	
Time (ms)	$\frac{di}{dt}$ (A/ms)	$v(t)$ (V)
$0 \leq t \leq 2$	-12	-192
$2 \leq t \leq 5$	+12	192
$5 \leq t \leq 9$	0	0
$9 \leq t \leq 11$	-12	-192
$11 \leq t \leq 12$	+12	192
$t > 12$	0	0

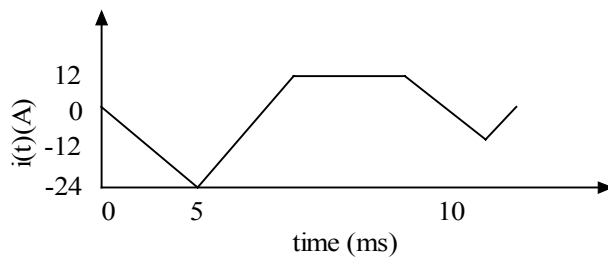

Problem 5.31

Draw the waveform for the voltage across a 10-mH inductor when the inductor current is given by the waveform shown in Figure P5.31

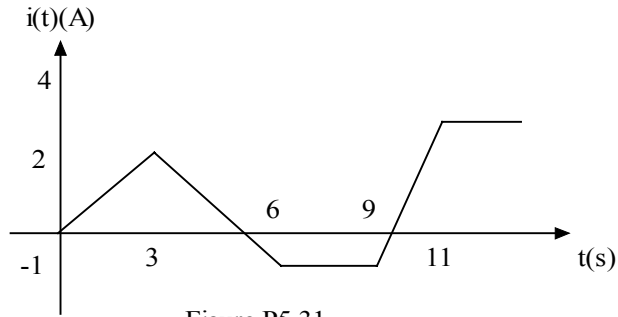

Suggested Solution

$$L = 10\text{mH}$$

$$v(t) = L \frac{di}{dt}$$

Time (s)	$\frac{di}{dt}$ (A/s)	$v(t)$ (mV)
$0 \leq t \leq 3$	$2/3$	6.67
$3 \leq t \leq 6$	-1	-10
$6 \leq t \leq 9$	0	0
$9 \leq t \leq 11$	2.5	25
$t > 11$	0	0

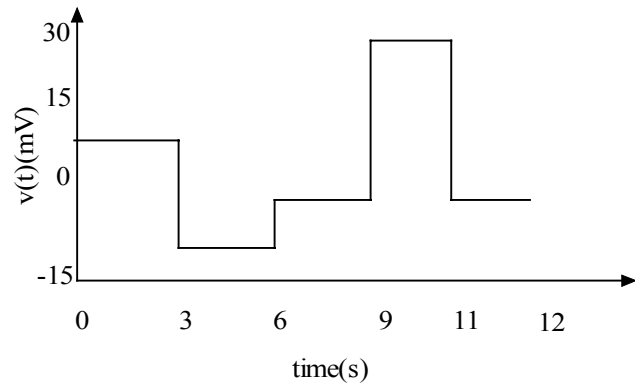
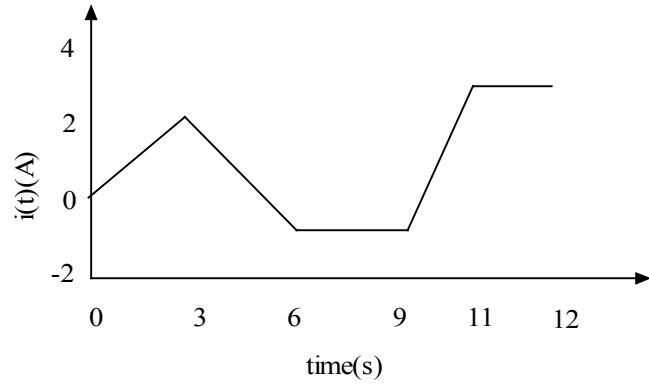

Problem 5.32

The voltage across a 10-mH inductor is shown in Figure P5.32. Determine the waveform for the inductor current

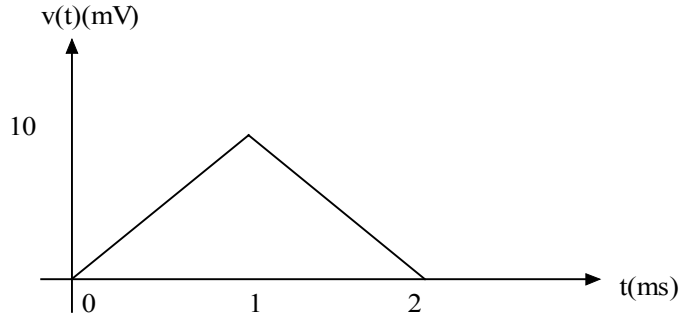

Figure P5.32

Suggested Solution

$$L = 10\text{mH} \quad i(t) = \frac{1}{L} \int v(t) dt$$

$$0 \leq t \leq 1\text{ms} \quad v(t) = 10t \text{ mV}$$

$$\text{assuming } i(0) = 0\text{A}, \quad i(t) = 500t^2 \text{ A}$$

$$1 \leq t \leq 2\text{ms} \quad v(t) = 10^{-2} - 10(t - 10^{-3})\text{V}$$

$$i(t) = \int (2 - 1000t) dt + K$$

where K = integration constant

$$i(t) = 2t - 500t^2 + K \text{ A}$$

Both equations for i(t) must be equal at t = 1ms.

$$500(10^{-3})^2 = 2(10^{-3}) - 500(10^{-3})^2 + K \Rightarrow K = -1\text{mA}$$

$$\text{So } i(t) = 2t - 500t^2 - 10^{-3} \text{ A}$$

$$i(t) = \begin{cases} 500t^2 \text{ A} & 0 \leq t \leq 1\text{ms} \\ 2t - 500t^2 - 10^{-3} \text{ A} & 1 \leq t \leq 2\text{ms} \\ 1 \text{ mA} & t > 2\text{ms} \end{cases}$$

Problem 5.33

The waveform for the voltage across a 20-mH inductor is shown in Figure P5.33. Compute the waveform for the inductor current.

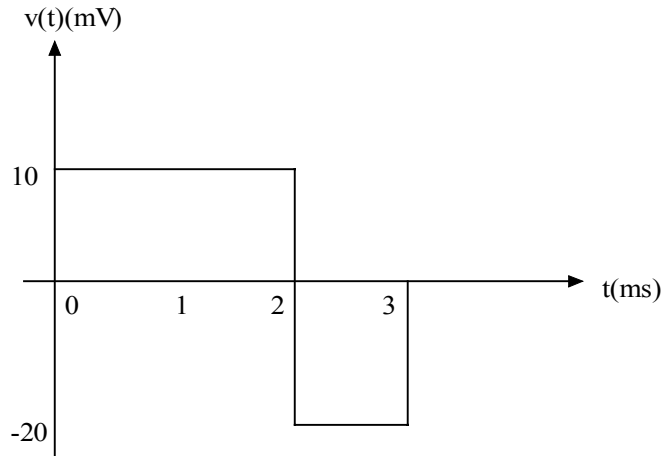

Figure P5.33

Suggested Solution

$$L = 20\text{mH} \quad i(t) = \frac{1}{L} \int v(t) dt$$

$$0 \leq t \leq 2\text{ms} \quad v(t) = 10\text{mV}$$

$$\text{i.e. } i(0) = 0\text{A}, \quad i(t) = 0.5t \text{ A}$$

$$2 \leq t \leq 3\text{ms} \quad v(t) = -20\text{mV}$$

$$i(t) = -(t - 2\text{m}) + i(2\text{m})$$

$$= -t + 2\text{m} + 1\text{m}$$

$$i(t) = (3 \times 10^{-3} - t) \text{ A}$$

$$t > 3\text{ms} \quad v(t) = 0\text{V}$$

$$i(t) = 0 + i(3\text{m}) = 0\text{A}$$

$$i(t) = \begin{cases} 0.5t & \text{A} & 0 \leq t \leq 2\text{ms} \\ 3 \times 10^{-3} - t & \text{A} & 2 \leq t \leq 3\text{ms} \\ 0 & \text{A} & t > 3\text{ms} \end{cases}$$

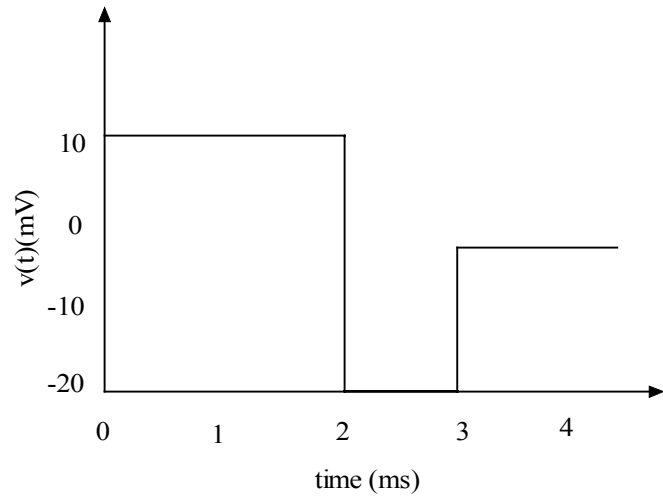

Problem 5.34

The voltage across a 2-H inductor is given by the waveform shown in Figure P5.34. Find the waveform for the current in the inductor.

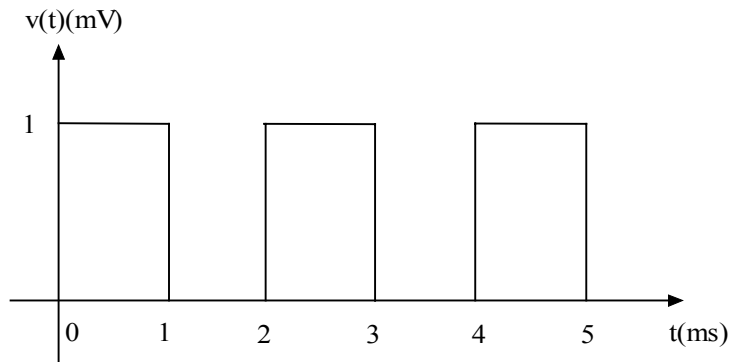

Figure P5.34

Suggested Solution

$$L = 2H \quad i(t) = \frac{1}{L} \int v(t) dt$$

$$0 \leq t \leq 1ms \quad \text{assume } i(0) = 0A$$

$$v(t) = 1mV$$

$$i(t) = 500t \quad \mu A$$

$$1 \leq t \leq 2mA \quad v(t) = 0V$$

$$i(t) = i(1ms) = \underline{0.5\mu A}$$

$$\underline{2ms \leq t \leq 3ms} \quad v(t) = 1mV$$

$$i(t) = 500(t - 2m) + K_1 \mu A$$

K_1 is an integrator constant,

$$i(2m) = 0.5\mu A = 500(2m - 2m) + K_1$$

$$K_1 = 0.5\mu A$$

$$\text{so, } i(t) = \underline{500t - 0.5\mu A}$$

$$\underline{3ms \leq t \leq 4ms} \quad v(t) = 0$$

$$i(t) = 0 + i(3m) = \underline{1\mu A}$$

$$\underline{4ms \leq t \leq 5ms} \quad v(t) = 1mV$$

$$i(t) = 500(t - 4m) + K_2 \mu A$$

$$i(4m) = 1\mu A = 500(4m - 4m) + K_2$$

$$K_2 = 1\mu A$$

$$i(t) = 500t - \underline{1\mu A}$$

$$t > 5ms \quad i(t) = \underline{1.5\mu A}$$

$i(t) =$	$500t$	μA	$0 \leq t \leq 1ms$
	0.5	μA	$1 \leq t \leq 2ms$
	$500t - 0.5$	μA	$2 \leq t \leq 3ms$
	1.0	μA	$3 \leq t \leq 4ms$
	$500t - 1$	μA	$4 \leq t \leq 5ms$
	1.5	μA	$t > 5ms$

Problem 5.35

Find the possible capacitance range of the following capacitors.

- a) $0.068 \mu\text{F}$ with a tolerance of 10%
- b) 120pF with a tolerance of 20%
- c) $39\mu\text{F}$ with a tolerance of 20%

Suggested Solution

- a) Minimum capacitor value = $0.9C = 61.2\text{nF}$
Maximum capacitor value = $1.1C = 74.8\text{nF}$
- b) Minimum capacitor value = $0.8C = 96\text{pF}$
Maximum capacitor value = $1.2C = 144\text{pF}$
- c) Minimum capacitor value = $0.8C = 31.2\mu\text{F}$
Maximum capacitor value = $1.2C = 46.8\mu\text{F}$

Problem 5.36

The capacitor in Figure P5.36a is 51 nF with a tolerance of 10%. Given the voltage waveform in Figure P5.36b graph the current $i(t)$ for the minimum and maximum capacitor values.

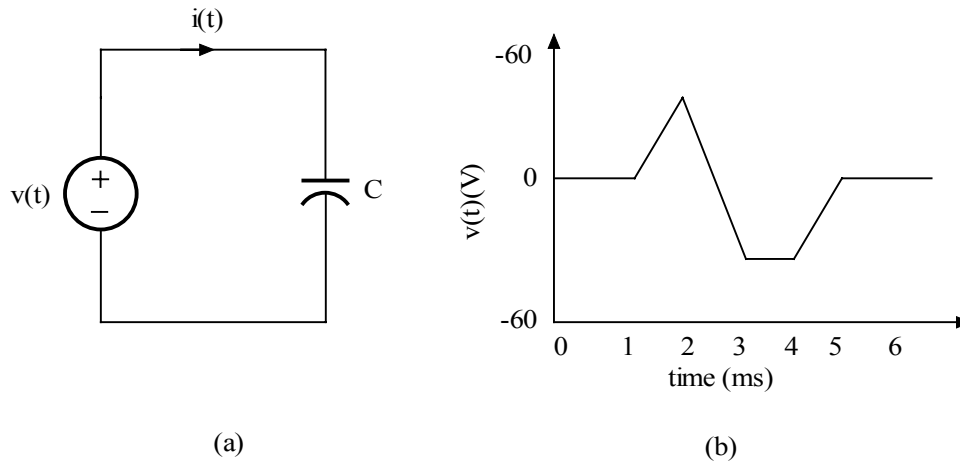

Figure P5.36

Suggested Solution

Maximum capacitor value = $1.1C = 56.1$ nF

Minimum capacitor value = $0.9C = 45.9$ nF

The capacitor voltage and current are related by the equation

$$i(t) = C \frac{dv(t)}{dt}$$

Problem 5.37

Find the possible inductance range of the following inductors

- a) 10 mH with a tolerance of 10%
- b) 2.0 nH with a tolerance of 5%
- c) 68 μ H with a tolerance of 10%

Suggested Solution

a)

Minimum inductor value = $0.9L = 0.9$ mH

Maximum inductor value = $1.1L = 1.1$ mH

b)

Minimum inductor value = $0.95L = 1.9$ nH

Maximum inductor value = $1.05L = 2.1$ nH

c)

Minimum inductor value = $0.9L = 61.2$ nH

Maximum inductor value = $1.1L = 74.8$ nH

Problem 5.38

The inductor in Figure P5.38a is $330\mu\text{H}$ with a tolerance of 5%. Given the current waveform in Figure P5.38b, graph the voltage $v(t)$ for the minimum and maximum inductor values.

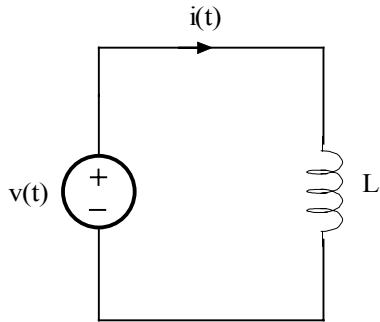

(a)

Figure P5.38

Suggested Solution

Maximum inductor value = $1.05L = 346.5 \mu\text{H}$

Minimum inductor value = $0.95L = 313.5 \mu\text{H}$

The inductor voltage and current are related by the equation

$$v(t) = L \frac{di(t)}{dt}$$

Problem 5.39

The inductor in Figure P5.39a is $4.7 \mu\text{H}$ with a tolerance of 20%. Given the current waveform in Figure P5.39b, graph the voltage $v(t)$ for the minimum and maximum inductor values.

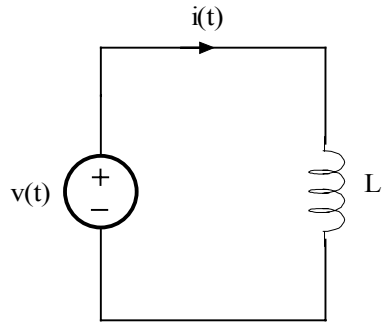

(a)

Figure P5.39

Suggested Solution

Maximum inductor value = $1.2L = 5.64 \mu\text{H}$

Minimum inductor value = $0.8L = 3.76 \mu\text{H}$

The inductor voltage and current are related by the equation

$$v(t) = L \frac{di(t)}{dt}$$

Problem 5.40

What values of capacitance can be obtained by interconnecting a 4- μF capacitor, a 6- μF capacitor, and a 12- μF capacitor?

Suggested Solution

Combo A

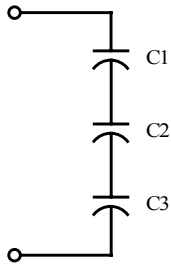

$$C_A = 1 / (1/C_1 + 1/C_2 + 1/C_3) = 2\mu\text{F}$$

Combo B

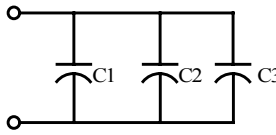

$$C_B = C_1 + C_2 + C_3 = 22\mu\text{F}$$

Combo C

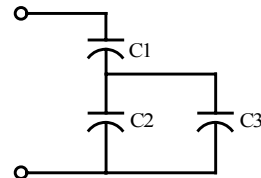

$$C_C = [C_1 (C_2 + C_3)] / [C_1 + (C_2 + C_3)]$$

$$C_C = 3.27\mu\text{F}$$

Combo D

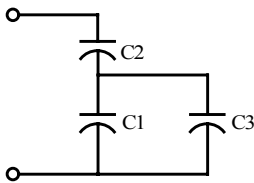

$$C_D = [C_2 (C_1 + C_3)] / [C_2 + (C_1 + C_3)]$$

$$C_D = 4.36\mu\text{F}$$

Combo E

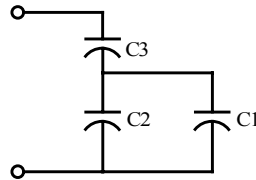

$$C_E = [C_3 (C_2 + C_1)] / [C_3 + (C_2 + C_1)]$$

$$C_E = 5.45\mu\text{F}$$

Combo F

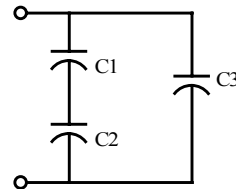

$$C_F = C_3 + C_1 C_2 / (C_1 + C_2) = 14.4\mu\text{F}$$

Combo G

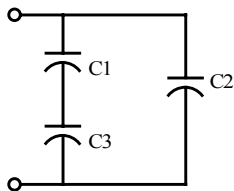

$$C_G = C_2 + C_1 C_3 / (C_1 + C_3) = 9\mu\text{F}$$

Combo H

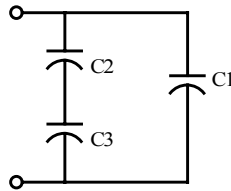

$$C_H = C_1 + C_2 C_3 / (C_2 + C_3) = 8\mu\text{F}$$

Possibilities:

$C_A = 2\mu\text{F}$
 $C_B = 22\mu\text{F}$
 $C_C = 3.27\mu\text{F}$
 $C_D = 4.36\mu\text{F}$
 $C_E = 4.45\mu\text{F}$
 $C_F = 14.4\mu\text{F}$
 $C_G = 9\mu\text{F}$
 $C_H = 8\mu\text{F}$

Problem 5.41

Given a 1, 3, and 4- μF capacitor, can they be interconnected to obtain an equivalent 2- μF capacitor?

Suggested Solution

$$C_1 = 1\mu\text{F} \quad C_2 = 3\mu\text{F} \quad C_3 = 4\mu\text{F}$$

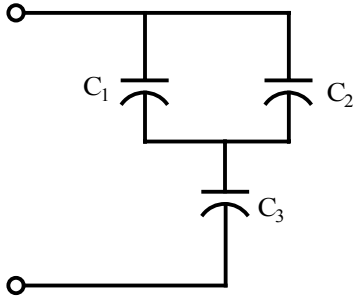

$$C_{eq} = \frac{(C_1 + C_2)C_3}{C_1 + C_2 + C_3} = \frac{(1\mu + 3\mu)4\mu}{1\mu + 3\mu + 4\mu} = \underline{2\mu\text{F}}$$

Problem 5.42

Given four 2- μF capacitors, find the maximum value and minimum value that can be obtained by interconnecting the capacitors in series/parallel combinations.

Suggested Solution

Minimum combo

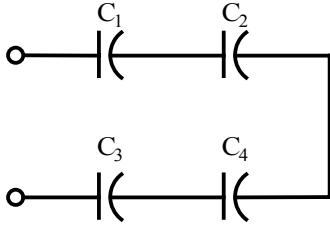

$$C_{\min} = \frac{1}{\frac{1}{C_1} + \frac{1}{C_2} + \frac{1}{C_3} + \frac{1}{C_4}} = 0.5\mu\text{F}$$

Maximum combo

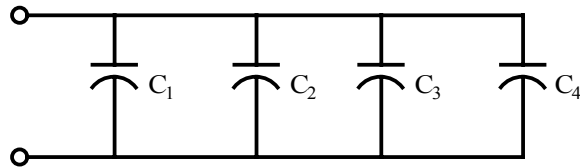

$$C_{\max} = C_1 + C_2 + C_3 + C_4 = 8\mu\text{F}$$

$C_{\min} = 0.5\mu\text{F}$
$C_{\max} = 8\mu\text{F}$

Problem 5.43

The two capacitors in Figure P5.42 were charged and then connected as shown. Determine the equivalent capacitance, the initial voltage at the terminals, and the total energy stored in the network.

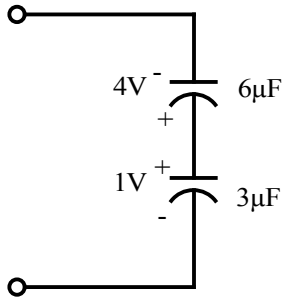
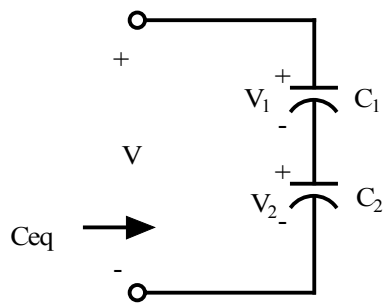

Figure 5.43

Suggested Solution



$$C_1 = 6\mu\text{F} \quad V_1 = -4\text{V}$$

$$C_2 = 3\mu\text{F} \quad V_2 = 1\text{V}$$

$$C_{eq} = C_1 C_2 / (C_1 + C_2) = 2\mu\text{F}$$

$$V = V_1 + V_2 = -3\text{V}$$

$$W = \frac{1}{2} C_1 V_1^2 + \frac{1}{2} C_2 V_2^2$$

$$W = 49.5\mu\text{J}$$

$C_{eq} = 2\mu\text{F}$
$V = -3\text{V}$
$W = 49.5\mu\text{J}$

Problem 5.44

Two capacitors are connected in series as shown in Figure P5.44. Find V_o

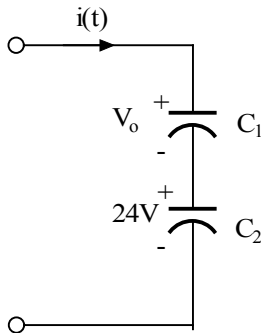

$$C_1 = 12\mu\text{F} \quad C_2 = 6\mu\text{F}$$

Suggested Solution

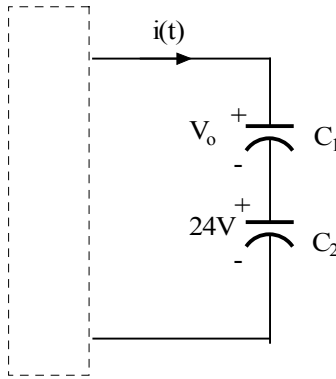

$$C_1 = 12\mu\text{F} \quad C_2 = 6\mu\text{F}$$

$$v_c = \frac{1}{c} \int i(t) dt$$

Since same current charged both caps,

$$C_1 V_o = C_2 (24)$$

$$V_o = 24(C_2 / C_1)$$

$$\boxed{V_o = 12V}$$

Problem 5.45

Three capacitors are connected as shown in Figure P5.45. Find V_1 and V_2 .

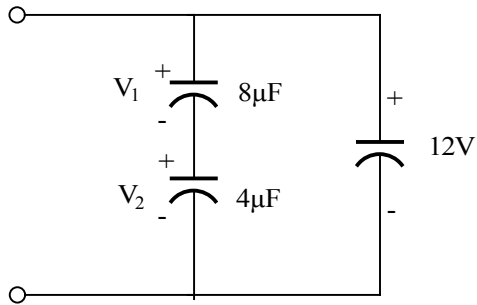
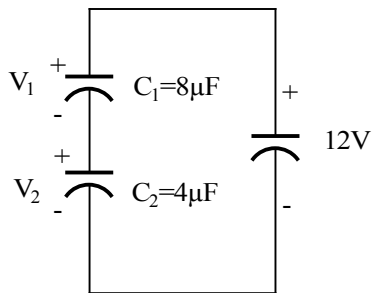

Figure 5.45

Suggested Solution



$$V_1 + V_2 = 12V$$

Assuming C_1 and C_2 are charged by the same current,

$$C_1 V_1 = C_2 V_2 \quad (\text{same as } Q_1 = Q_2)$$

$$V_1 = 12 \frac{C_2}{C_1 + C_2} = 4V$$

$$V_2 = 12 \frac{C_1}{C_1 + C_2} = 8V$$

$$\boxed{V_1 = 4V}$$

$$\boxed{V_2 = 8V}$$

Problem 5.46

Select the value of C to produce the desired total capacitance of $C_T=2\mu\text{F}$ in the circuit in Figure P5.46

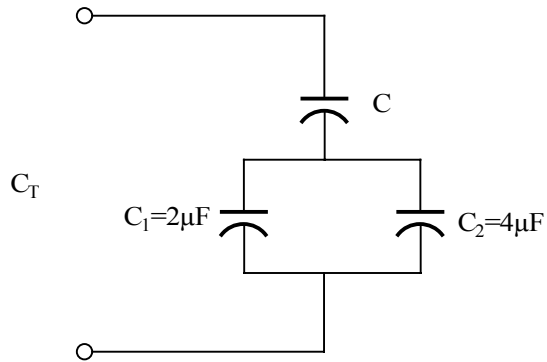

Suggested Solution

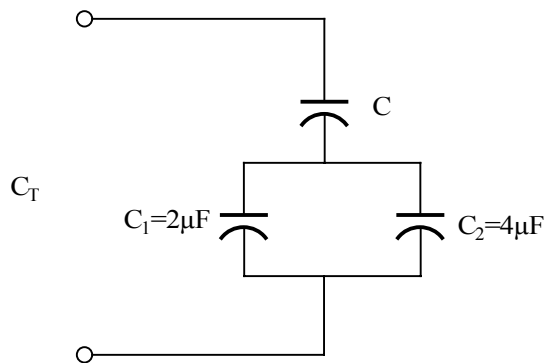

$$C_T = \frac{C(C_1 + C_2)}{C + C_1 + C_2} \Rightarrow 2 = \frac{6C}{6 + C}$$

$$12 + 2C = 6C \Rightarrow 4C = 12$$

$$\boxed{C = 3\mu\text{F}}$$

Problem 5.47

Select the value of C to produce the desired total capacitance of $C_T = 1\mu\text{F}$ in the circuit in Figure P5.47.

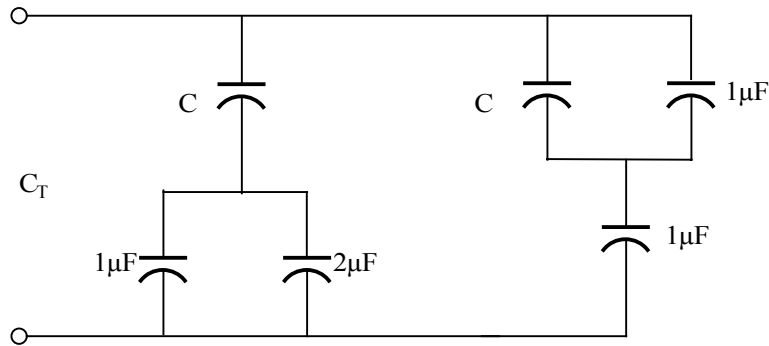

Figure P5.57

Suggested Solution

$$C_T = 1 = \frac{3C}{3+C} + \frac{(1+C)(1)}{(1+C)+1}$$

$$1 = \frac{3C}{3+C} + \frac{1+C}{2+C}$$

$$(3+C)(2+C) = 3C(2+C) + (3+C)(1+C)$$

$$0 = 3C^2 + 5C - 3$$

$$C_1, C_2 = \frac{-5 \pm \sqrt{25 - 4(3)(-3)}}{2(3)}$$

$$\boxed{C = 0.47\mu\text{F}}$$

Problem 5.48

Find the equivalent capacitance at terminals A-B in Figure P5.48

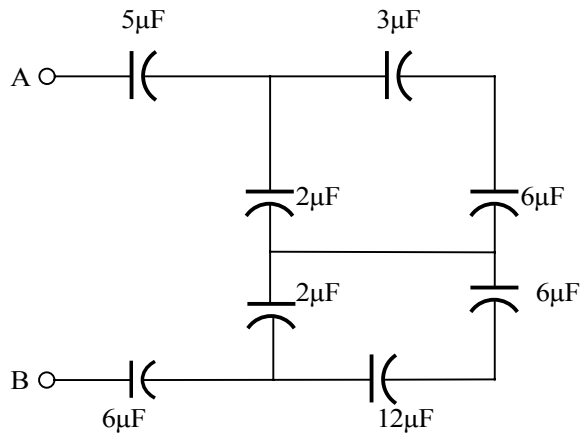
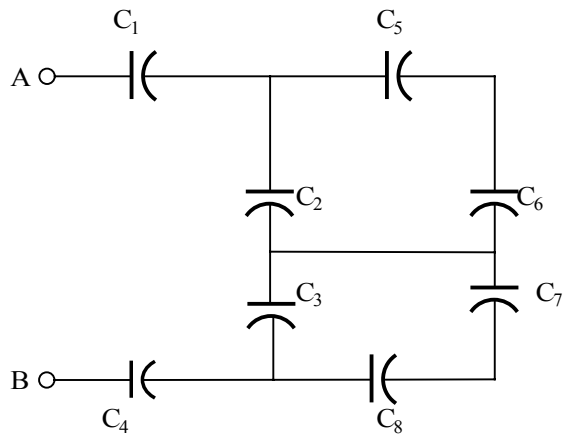

Figure 5.48

Suggested Solution



$C_1 = 5\mu\text{F}$	$C_4 = 6\mu\text{F}$	$C_6 = 6\mu\text{F}$
$C_2 = 2\mu\text{F}$	$C_5 = 3\mu\text{F}$	$C_7 = 6\mu\text{F}$
$C_3 = 2\mu\text{F}$	$C_8 = 12\mu\text{F}$	

$$C_{eq1} = \frac{C_5 C_6}{C_5 + C_6} = 2\mu\text{F}$$

$$C_{eq2} = C_2 + C_{eq1} = 4\mu\text{F}$$

$$C_{eq3} = \frac{C_7 C_8}{C_7 + C_8} = 4\mu\text{F}$$

$$C_{eq4} = C_3 + C_{eq3} = 6\mu\text{F}$$

$$\frac{1}{C_{eq5}} = \frac{1}{C_{eq2}} + \frac{1}{C_{eq4}} \Rightarrow C_{eq5} = 2.4\mu\text{F}$$

$$\frac{1}{C_{AB}} = \frac{1}{C_1} + \frac{1}{C_4} + \frac{1}{C_{eq5}} \Rightarrow \boxed{C_{AB} = 1.32\mu\text{F}}$$

Problem 5.49

Determine the total capacitance of the network in Figure P5.49

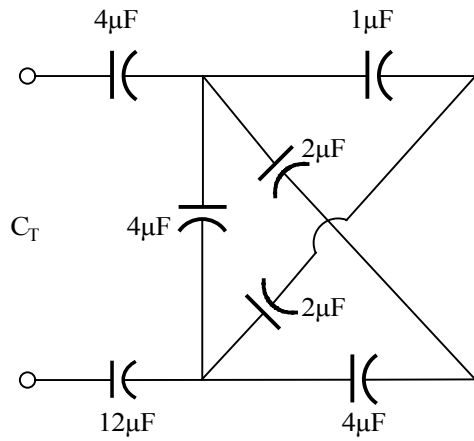
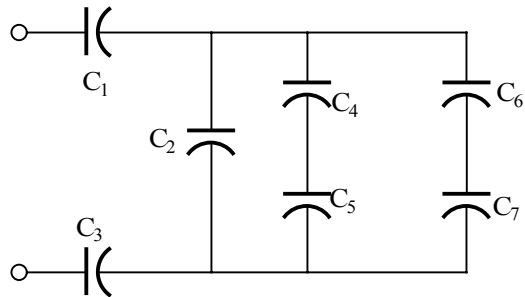

Figure P5.49

Suggested Solution



$$\begin{aligned}
 C_1 &= 4\mu\text{F} & C_4 &= 1\mu\text{F} & C_6 &= 2\mu\text{F} \\
 C_2 &= 4\mu\text{F} & C_5 &= 2\mu\text{F} & C_7 &= 4\mu\text{F} \\
 C_3 &= 12\mu\text{F}
 \end{aligned}$$

$$C_{AB} = \frac{(C_4 + C_6)(C_5 + C_7)}{(C_4 + C_6) + (C_5 + C_7)}$$

$$C_{AB} = 2\mu\text{F}$$

$$\frac{1}{C_T} = \frac{1}{C_2 + C_{AB}} + \frac{1}{C_1} + \frac{1}{C_3} = \frac{1}{6} + \frac{1}{4} + \frac{1}{12}$$

$$\boxed{C_T = 2\mu\text{F}}$$

Problem 5.50

Find C_T in the network in Figure P5.50 if (a) the switch is open and (b) the switch is closed.

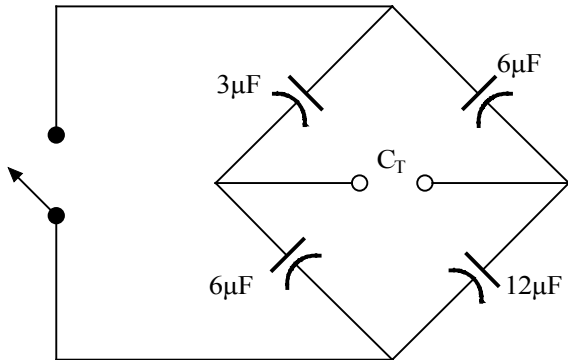
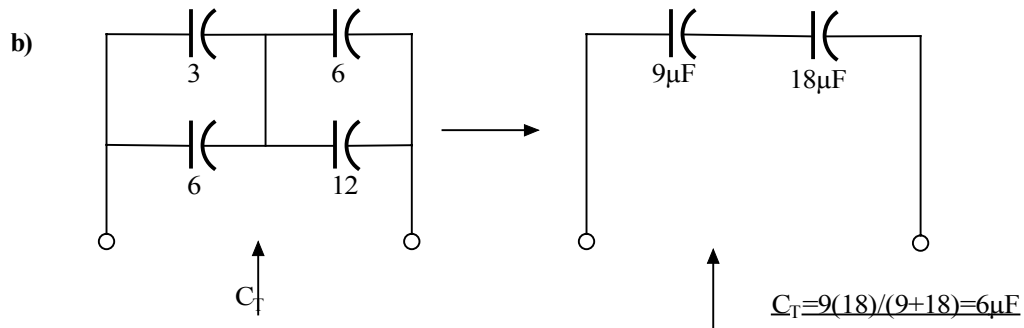
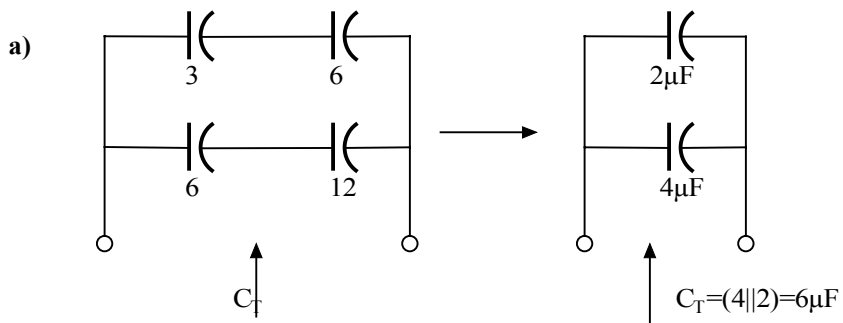

Figure P5.50

Suggested Solution

The networks can be reduced as follows:



Problem 5.51

Find the total capacitance C_T of the network in Figure P5.51.

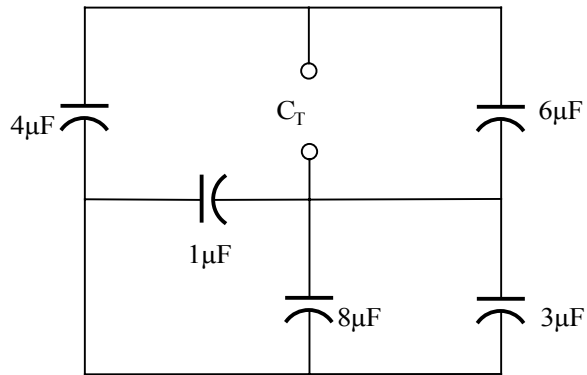
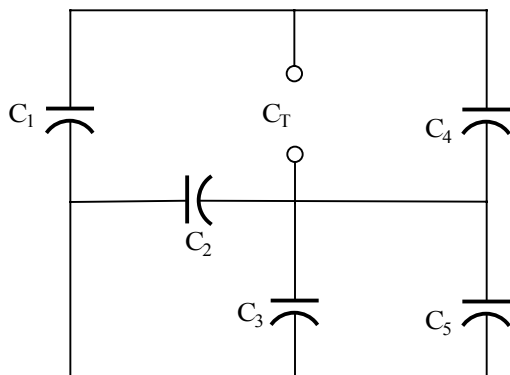

Figure P5.51

Suggested Solution



$$C_1 = 4\mu\text{F}$$

$$C_2 = 1\mu\text{F}$$

$$C_3 = 8\mu\text{F}$$

$$C_4 = 6\mu\text{F}$$

$$C_5 = 3\mu\text{F}$$

$$C_{\text{eq1}} = C_2 + C_3 + C_5 = 12\mu\text{F}$$

$$C_{\text{eq2}} = C_1 C_{\text{eq1}} / (C_1 + C_{\text{eq1}}) = 3\mu\text{F}$$

$$C_T = C_4 + C_{\text{eq2}} = 9\mu\text{F}$$

$$C_T = 9\mu\text{F}$$

Problem 5.52

Compute the equivalent capacitance of the network in Figure P5.52 if all the capacitors are $5\mu\text{F}$.

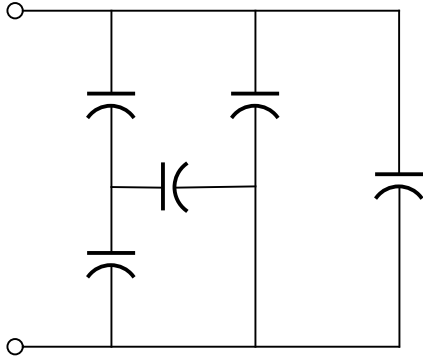
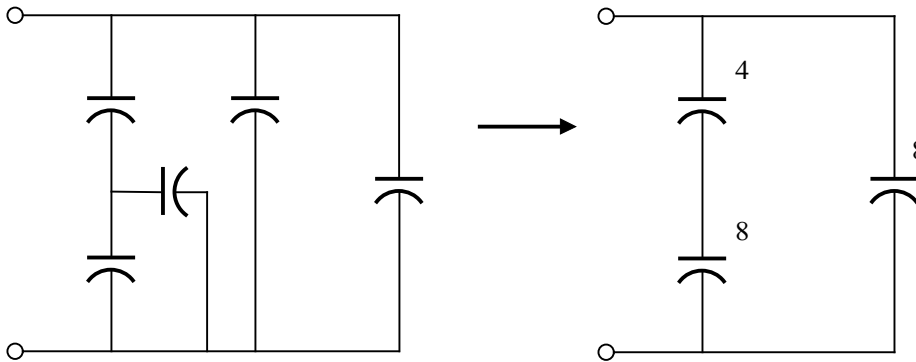

Figure P5.52

Suggested Solution



$$C_{eq} = 4(8)/12 + 8 = 32/3 \mu\text{F}$$

Problem 5.53

If all the capacitors in Figure P5.53 are $6\ \mu\text{F}$, find C_{eq}

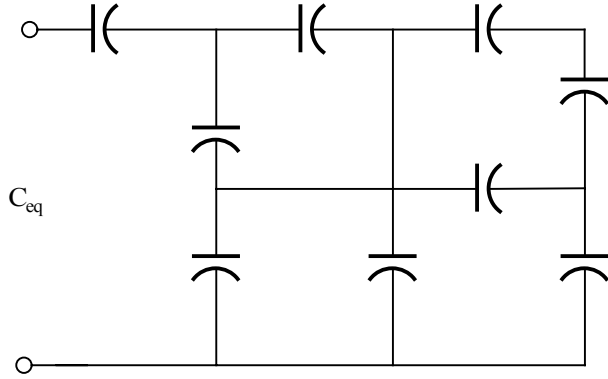
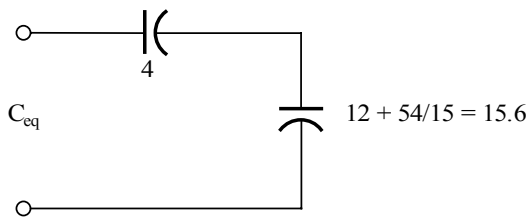
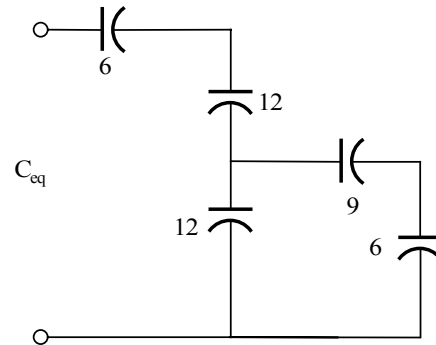
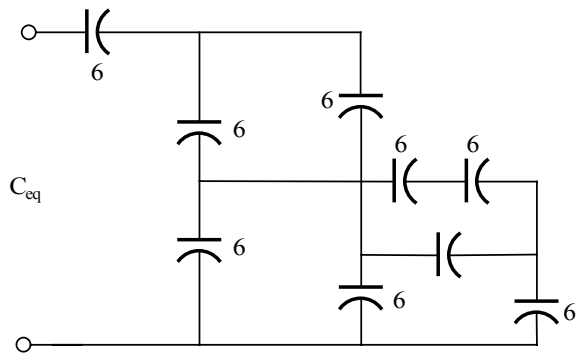

Figure P5.53

Suggested Solution



$C_{\text{eq}} = 4(15.6)/(19.6) = 3.18\ \mu\text{F}$

Problem 5.54

Given the capacitors in Figure 5.54 are $C_1=2.0\mu\text{F}$ with a tolerance of 2% and $C_2=2.0\mu\text{F}$ with a tolerance of 20%, find

- a) the nominal value of C_{EQ}
- b) the minimum and maximum possible values of C_{EQ}
- c) the percent errors of the minimum and maximum values

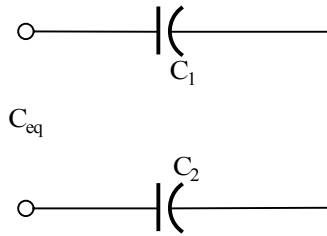

Figure P5.54

Suggested Solution

a) The nominal value is

$$C_{EQ} = C_1 + C_2 + C_3 = (0.1 + 0.33 + 1) \times 10^{-6} = \underline{1.43 \mu\text{F}}$$

b) The minimum value of C_{EQ} is

$$C_{EQ,\min} = C_{1,\min} + C_{2,\min} + C_{3,\min} = (0.1 \times 0.9 + 0.33 \times 0.8 + 1 \times 0.9) \times 10^{-6} = \underline{1.254 \mu\text{F}}$$

The maximum value of C_{EQ} is

$$C_{EQ,\max} = C_{1,\max} + C_{2,\max} + C_{3,\max} = (0.1 \times 1.1 + 0.33 \times 1.2 + 1 \times 1.1) \times 10^{-6} = \underline{1.606 \mu\text{F}}$$

c) The percent error of the minimum value is

$$\frac{1.254 - 1.43}{1.43} \times 100 = \underline{-12.3\%}$$

The percent error of the maximum value is

$$\frac{1.606 - 1.43}{1.43} \times 100 = \underline{12.3\%}$$

Problem 5.55

Given the capacitors in Figure 5.55 are $C_1=0.1\mu\text{F}$ with a tolerance of 2% and $C_2=0.33\mu\text{F}$ with a tolerance of 20% and $1\mu\text{F}$ with a tolerance of 10%. Find the following.

- a) the nominal value of C_{EQ}
- b) the minimum and maximum possible values of C_{EQ}
- c) the percent errors of the minimum and maximum values

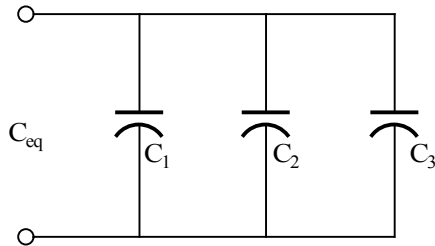

Figure P5.55

Suggested Solution

a) The nominal value is

$$C_{EQ} = \frac{C_1 C_2}{C_1 + C_2} = \frac{(2.0)(2.0)}{2.0 + 2.0} \times 10^{-6} = \underline{1.0\mu\text{F}}$$

b) The minimum value of C_{EQ} is

$$C_{EQ,\min} = \frac{C_{1,\min} C_{2,\min}}{C_{1,\min} + C_{2,\min}} = \frac{(2.0 * 0.98)(2.0 * 0.8)}{(2.0 * 0.98) + (2.0 * 0.8)} \times 10^{-6} = \underline{0.881\mu\text{F}}$$

The maximum value of C_{EQ} is

$$C_{EQ,\max} = \frac{C_{1,\max} C_{2,\max}}{C_{1,\max} + C_{2,\max}} = \frac{(2.0 * 1.02)(2.0 * 1.2)}{(2.0 * 1.02) + (2.0 * 1.2)} \times 10^{-6} = \underline{1.103\mu\text{F}}$$

c) The percent error of the minimum value is

$$\frac{0.881 - 1.0}{1.0} \times 100 = \underline{-11.9\%}$$

The percent error of the maximum value is

$$\frac{1.103 - 1}{1} \times 100 = \underline{10.3\%}$$

Problem 5.56

Select the value of L that produces a total inductance of $L_T = 10\text{mH}$ in the circuit in Figure P5.56

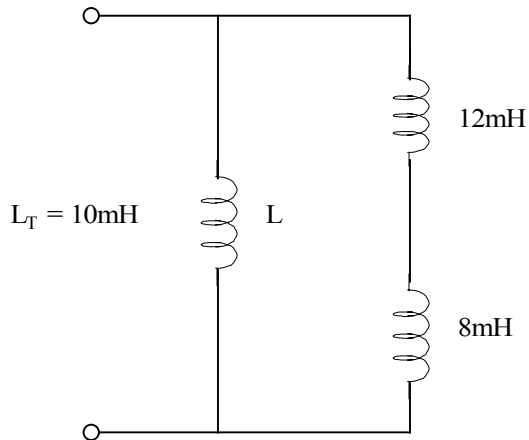
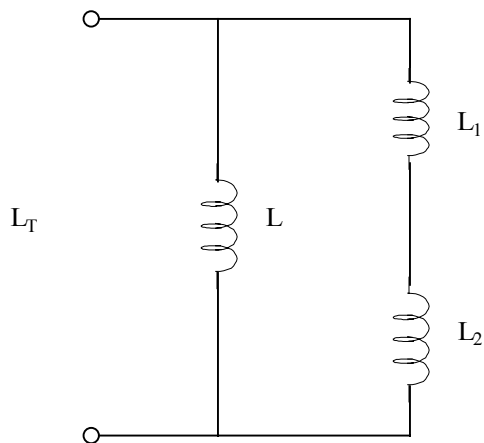

Figure P5.56

Suggested Solution



$$L_T = (L_1 + L_2) L / (L_1 + L_2 + L)$$

$$10 = 20 L / (20 + L)$$

$$200 + 10L = 20L$$

$$\underline{L = 20\text{mH}}$$

Problem 5.57

Find the value of L in the network in Figure P5.57 so that the total inductance L_T will be 2 mH.

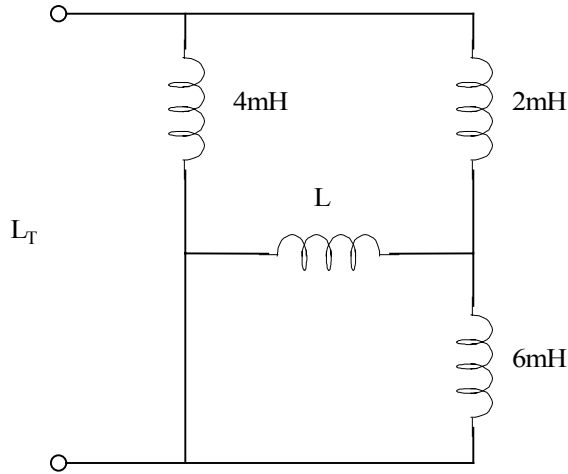
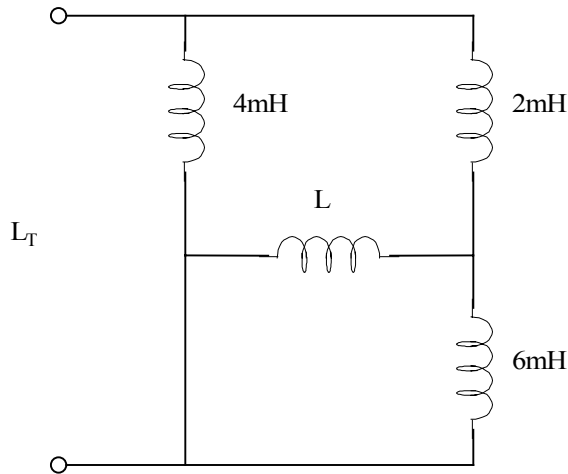

Figure P5.57

Suggested Solution



All L's in mH

$$\frac{[\frac{6L}{6+L} + 2]4}{\frac{6L}{6+L} + 2 + 4} = 2$$

$$\frac{\frac{24L}{6+L} + 8}{\frac{6L}{6+L} + 6} = 2$$

$$24L + 8(6 + L) = (6L + (6 + L))2$$

$$24L + 48 + 8L = 12L + 72 + 12L$$

$$8L = 24$$

$$\boxed{L = 3mH}$$

Problem 5.58

Find the value of L in the network in Figure 5.58 so that the value of L_T will be 2 mH.

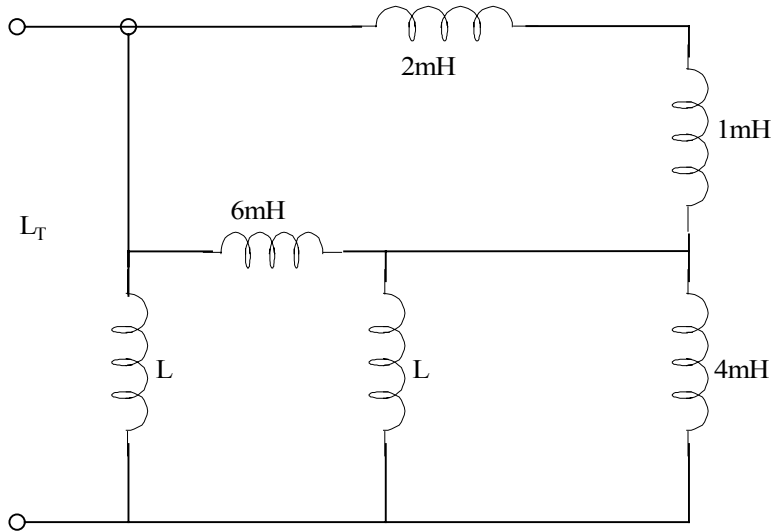
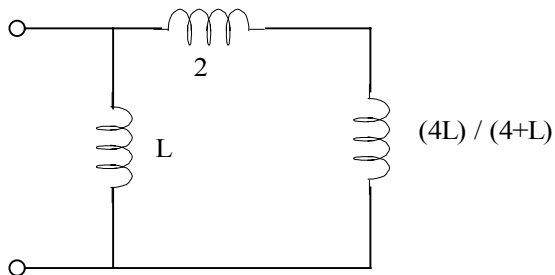

Figure P5.58

Suggested Solution



$$\frac{[\frac{4L}{4+L} + 2]L}{\frac{4L}{4+L} + 2 + L} = 2$$

$$6L^2 + 8L = 2L^2 + 20L + 16$$

$$(L + 4)(L + 1) = 0$$

$$\boxed{L = 4mH}$$

Problem 5.59

Determine the inductance at terminals A-B in the network in Figure P5.59.

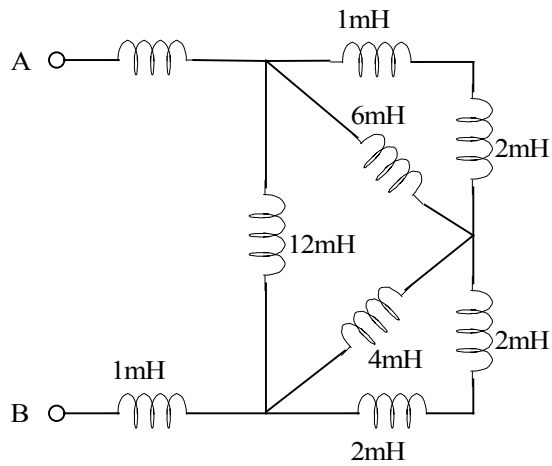
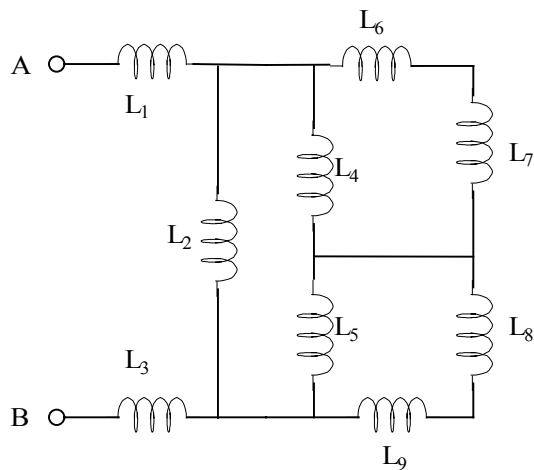

Figure 5.59

Suggested Solution



$$\begin{aligned}
 L_1 = L_3 = L_6 &= 1\text{mH} & L_2 &= 12\text{mH} \\
 L_4 &= 6\text{mH} & L_5 &= 4\text{mH} \\
 L_7 = L_8 = L_9 &= 2\text{mH}
 \end{aligned}$$

$$L_{eq1} = L_6 + L_7 = 3mH$$

$$L_{eq2} = L_4 L_{eq1} / (L_4 + L_{eq1}) = 2mH$$

$$L_{eq3} = L_8 + L_9 + 4mH$$

$$L_{eq4} = L_{eq3} L_5 / (L_{eq3} + L_5) = 2mH$$

$$L_{eq5} = \frac{L_2(L_{eq2} + L_{eq4})}{L_2 + L_{eq2} + L_{eq4}} = 3mH$$

$$L_{AB} = L_1 + L_3 + L_{eq5} = 5mH$$

$$\boxed{L_{AB} = 5mH}$$

Problem 5.60

Compute the equivalent inductance of the network in Figure P5.60 if all inductors are 5 mH

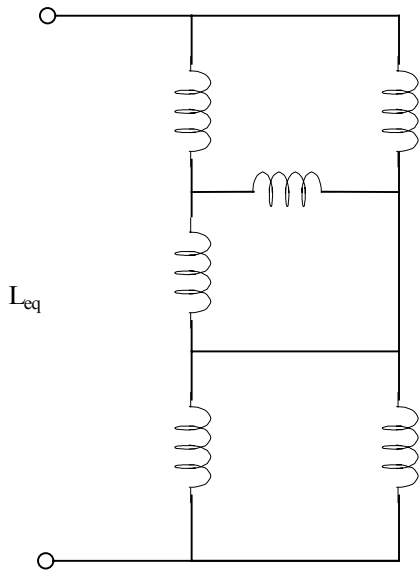
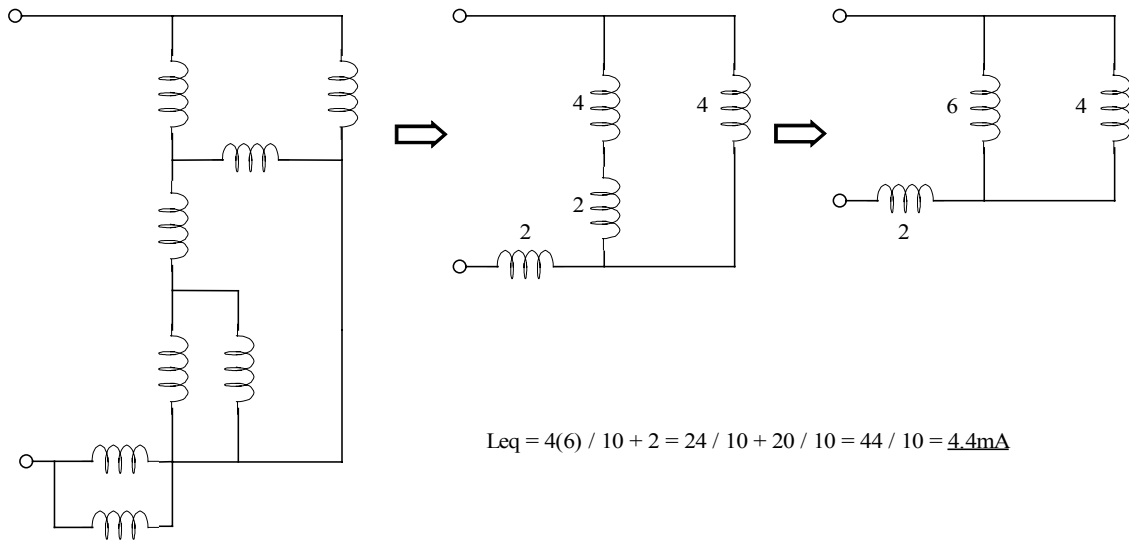

Figure 5.60

Suggested Solution

Redrawing the network



$$L_{eq} = 4(6) / 10 + 2 = 24 / 10 + 20 / 10 = 44 / 10 = \underline{4.4\text{mH}}$$

Problem 5.61

Determine the inductance at terminals A-B in the network in Figure P5.61

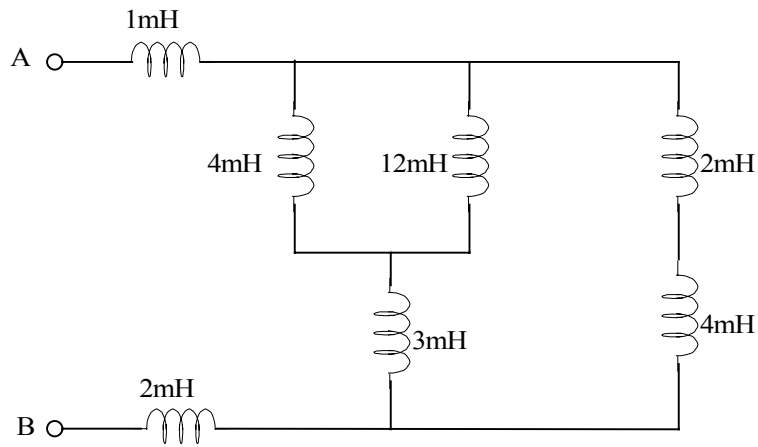
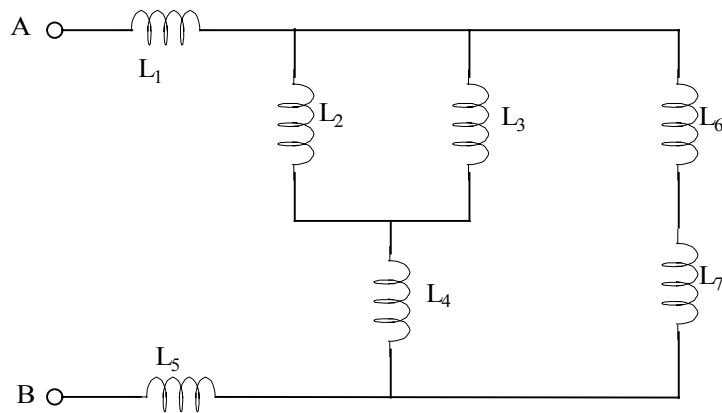

Figure 5.61

Suggested Solution



$$L_1 = 1\text{mH} \quad L_2 = L_7 = 4\text{mH} \quad L_3 = 12\text{mH}$$

$$L_4 = 3\text{mH} \quad L_5 = L_6 = 2\text{mH}$$

$$L_{eq1} = L_6 + L_7 = 6mH$$

$$L_{eq2} = L_2 L_3 / (L_2 + L_3) = 3mH$$

$$L_{eq3} = L_{eq2} + L_4 = 6mH$$

$$L_{eq4} = L_{eq1} L_{eq3} / (L_{eq1} + L_{eq3})$$

$$L_{eq4} = 3mH$$

$$L_{AB} = L_1 + L_{eq4} + L_5$$

$$\boxed{L_{AB} = 6mH}$$

Problem 5.62

Find the total inductance at the terminals of the network in Figure P5.62

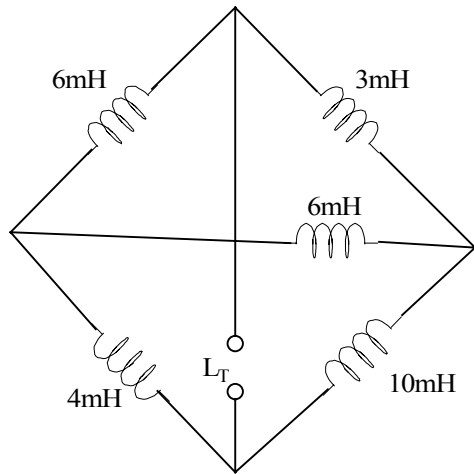
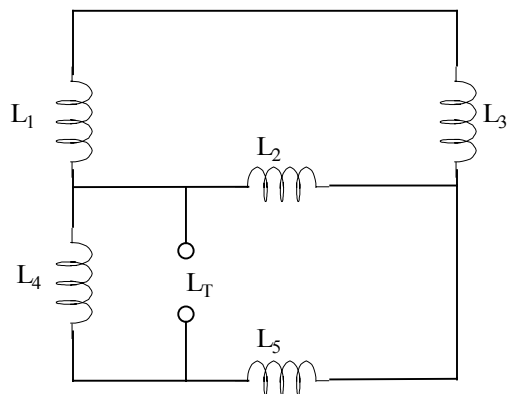

Figure 5.62

Suggested Solution



- $L_1 = 6\text{mH}$
- $L_2 = 6\text{mH}$
- $L_3 = 3\text{mH}$
- $L_4 = 4\text{mH}$
- $L_5 = 10\text{mH}$

L_1 is shorted out!

$$L_{eq1} = L_2 L_3 / (L_2 + L_3) = 2\text{mH}$$

$$L_{eq2} = L_{eq1} + L_5 = 10\text{m} + 2\text{m} = 12\text{mH}$$

$$L_T = L_4 L_{eq2} / (L_4 + L_{eq2})$$

$L_T = 3\text{mH}$

Problem 5.63

Given the network shown in Figure P5.63 find (a) the equivalent inductance at terminals A-B with terminals C-D short circuited. And (b) the equivalent inductance at terminals C-D with terminals A-B open circuited.

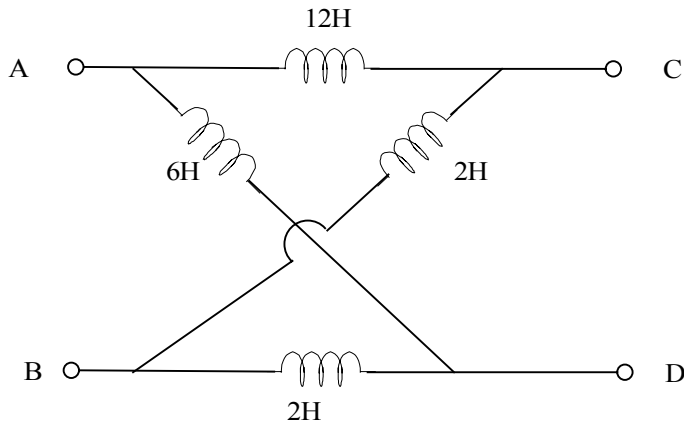
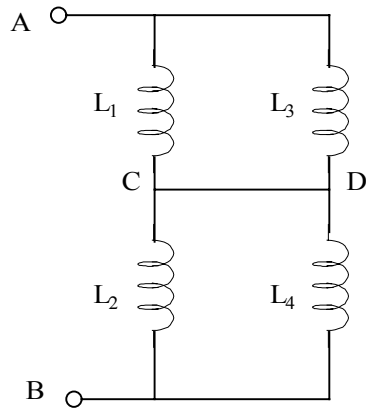

Figure P5.63

Suggested Solution



$$L_1 = 12\text{H}$$

$$L_2 = 2\text{H}$$

$$L_3 = 6\text{H}$$

$$L_4 = 2\text{H}$$

$$L_{\text{eq1}} = L_1 L_3 / (L_1 + L_3) = 4\text{H}$$

$$L_{\text{eq2}} = L_2 L_4 / (L_2 + L_4) = 1\text{H}$$

$$L_{\text{AB}} = L_{\text{eq1}} + L_{\text{eq2}}$$

$$\underline{L_{\text{AB}} = 5\text{H}}$$

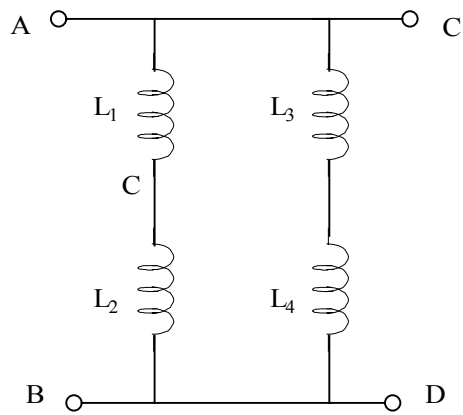

$$L_{\text{eq3}} = L_1 + L_3 = 18\text{H}$$

$$L_{\text{eq4}} = L_2 + L_4 = 4\text{H}$$

$$1/L_{\text{CD}} = 1/L_{\text{eq3}} + 1/L_{\text{eq4}}$$

$$\underline{L_{\text{CD}} = 3.27\text{H}}$$

Problem 5.64

For the network in Figure P5.64 choose C such that

$$v_o = -10 \int v_s dt$$

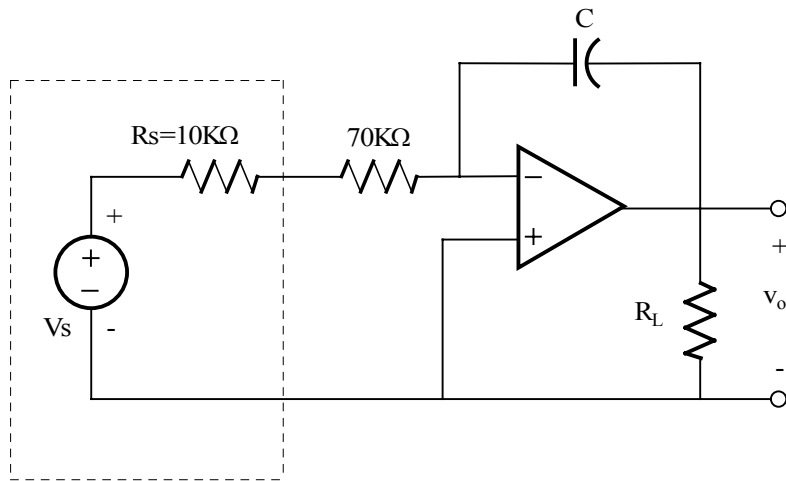
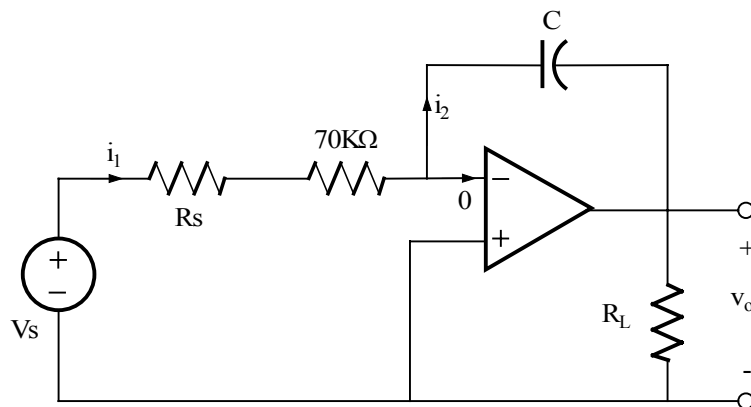

Figure P5.64

Suggested Solution



$$R_s = 10K\Omega$$

$$v_o = -10 \int v_s dt$$

$$R_{eq} = R_s + 70K = 80K$$

Using ideal op-amp assumptions,

$$i_1 = i_2$$

$$\frac{v_s - 0}{R_{eq}} = -C \frac{dv_o}{dt} \Rightarrow v_o = -\frac{1}{R_{eq} C} \int v_s dt$$

So,

$$R_{eq} C = \frac{1}{10} \Rightarrow \boxed{C = 1.25 \mu F}$$

Problem 5.65

For the network in Figure P5.65, $v_s(t) = 120 \cos 377t$ V. Find $v_o(t)$

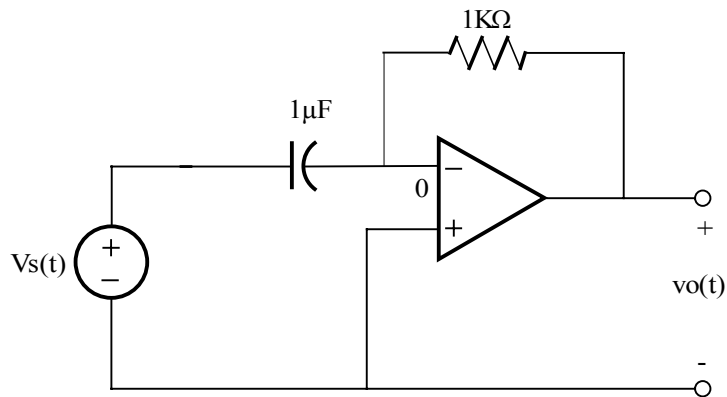
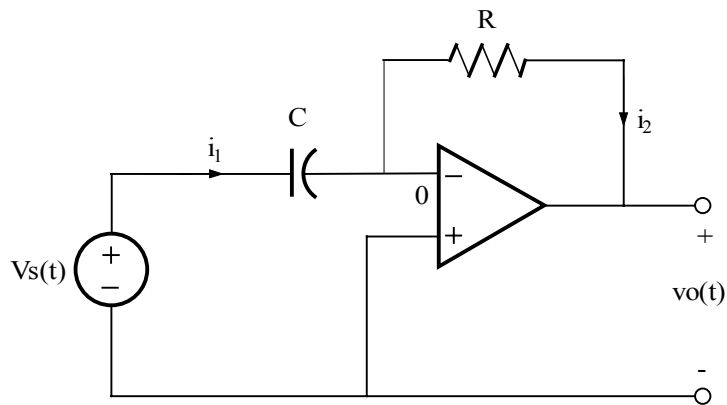

Figure P5.65

Suggested Solution



$$C = 1\mu F \quad R = 1K\Omega$$

$$v_s = 120 \cos 377t \text{ V}$$

$$i_1 = i_2 \quad (\text{ideal op-amp assumptions})$$

$$C \frac{dv_s}{dt} = -\frac{v_o}{R} \Rightarrow v_o = -RC \frac{dv_s}{dt}$$

$$v_o(t) = +(1k)(1\mu)(120)(377) \sin(377)t$$

$$v_o(t) = 45.24 \sin(377t) \text{ V}$$

Problem 5.66

For the network in Figure P5.66, $v_s(t)=115\sin 377t$ V. Find $v_o(t)$

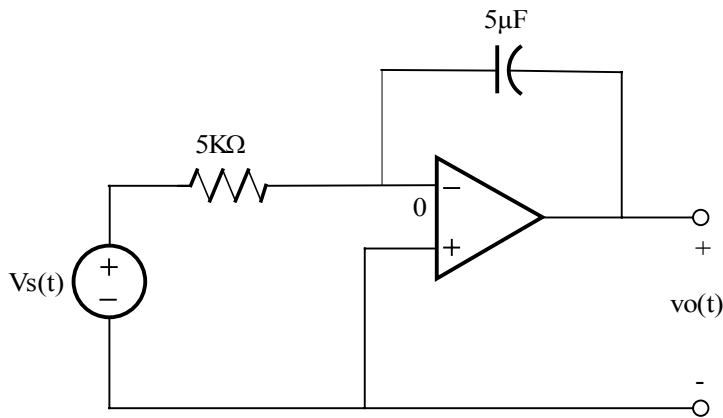
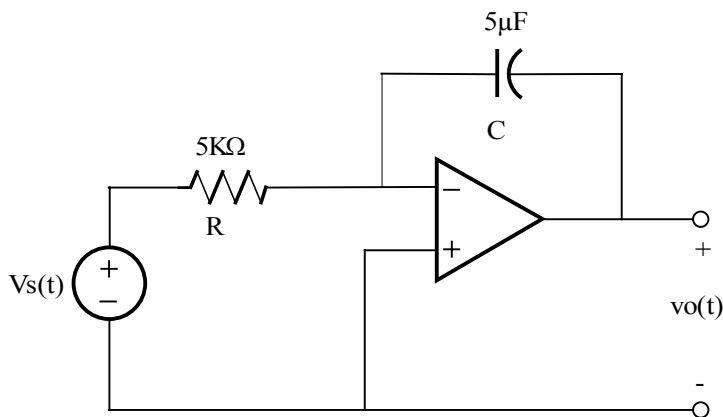

Figure P5.66

Suggested Solution



$$v_o(t) = -\frac{1}{RC} \int v_s dt$$
$$= \frac{115}{(5K)(5\mu)(377)} \cos(377t)$$

$$v_o(t) = 12.20 \cos(377t) \text{ V}$$

Problem 5FE-1

Given three capacitors with values $2\mu\text{F}$, $4\mu\text{F}$ and $6\mu\text{F}$, can the capacitors be interconnected so that the combination is an equivalent $3\mu\text{F}$?

Suggested Solution

Yes.

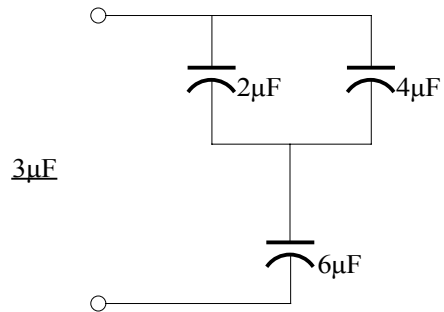

Problem 5FE-2

The current pulse shown in Figure 5PFE-2 is applied to a $1\mu\text{F}$ capacitor. Determine the charge on the capacitor and the energy stored.

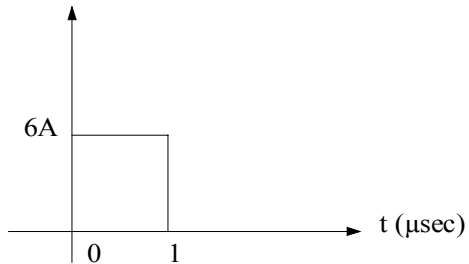

Figure PFE-2

Suggested Solution

The capacitor voltage is

$$v(t) = \frac{1}{C} \int_0^t i(t) dt = \frac{1}{10^{-6}} \int_0^{10^{-6}} 6 dt = 6V$$

$$Q = CV = 10^{-6} \times 6 = 6\mu\text{C}$$

$$W = \frac{1}{2} CV^2 = \frac{1}{2} (10^{-6})(6)^2 = \underline{18\mu\text{J}}$$

Problem 5FE-3

In the network shown in Figure 5PFE-3, determine the energy stored in the unknown capacitor C_x .

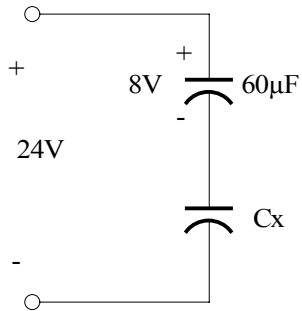
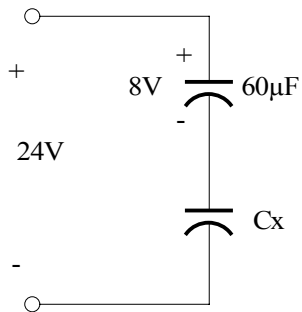

Figure PFE-3

Suggested Solution



$$Q = CV = (60 \times 10^{-6})(8) = 480 \mu\text{C}$$

$$V_x = 24 - 8 = 16\text{V}$$

$$C_x = Q/V_x = (480 \times 10^{-6}) / 16 = 30 \mu\text{F}$$

$$W = \frac{1}{2} CV^2$$

$$= \frac{1}{2} (30 \times 10^{-6}) (16)^2$$

$$\underline{W = 3.84 \text{mJ}}$$

Problem 6.1

Use the differential equation approach to find $V_c(t)$ for $t > 0$ in the circuit in Fig. P6.1

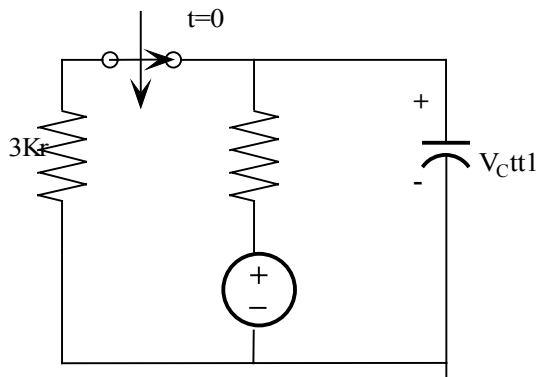

Suggested Solution

$$V_c(0^-) = 12 \left(\frac{3k}{9k} \right) = 4V$$

$$\frac{V_c(t) - 12}{6k} + \frac{cdv_c(t)}{dt} = 0$$

OR

$$\frac{dV_c(t)}{dt} + \frac{V_c(t)}{0.6} = 12$$

$$V_c(t) = k_1 + k_2 e^{-t/0.6}$$

$$\text{At } t = 0, k_1 + k_2 = 4 \text{ and at } t = \infty, k_1 = 12 \therefore k_2 = -8$$

$$\text{Hence } V_c(t) = 12 - 8e^{-t/0.6} V, t > 0$$

Problem 6.2

Use the differential equation approach to find $i(t)$ for $t > 0$ in the network in Fig P6.2 as shown.

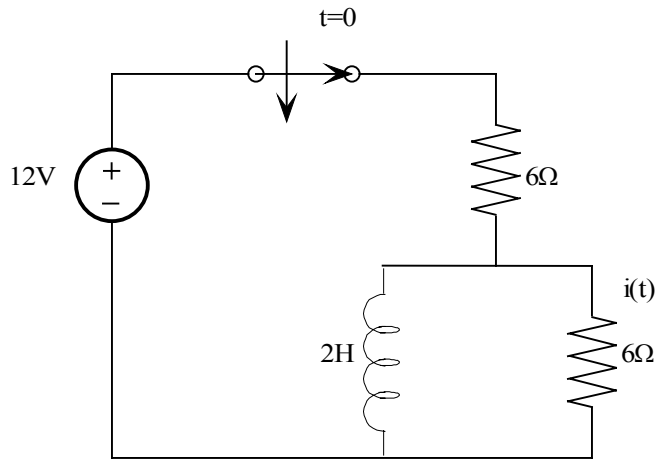

Suggested Solution

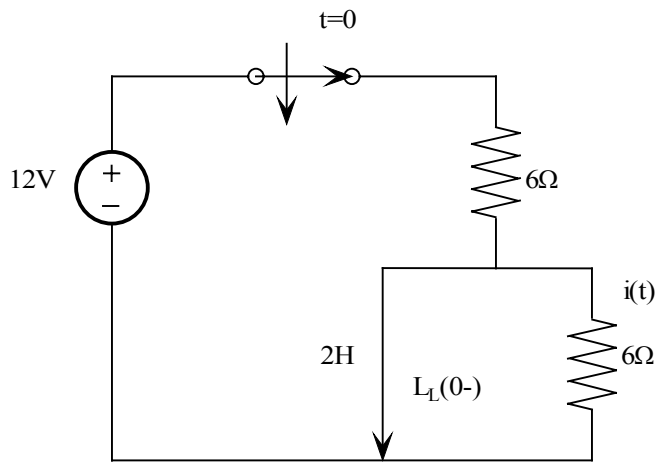

$$i_L(0^-) = 2A$$

$$Ld \frac{i(t)}{dt} + Ri(t) = 0$$

$$i(t) = K_2 e^{-R/2t} = K_2 e^{-3t}$$

$$i(0) = 2 = K_2 \therefore i(t) = 2e^{-3t} A \quad t > 0$$

Problem 6.3

Use the differential equation approach to find $V_C(t)$ for $t > 0$ in the circuit in Fig. P6.3

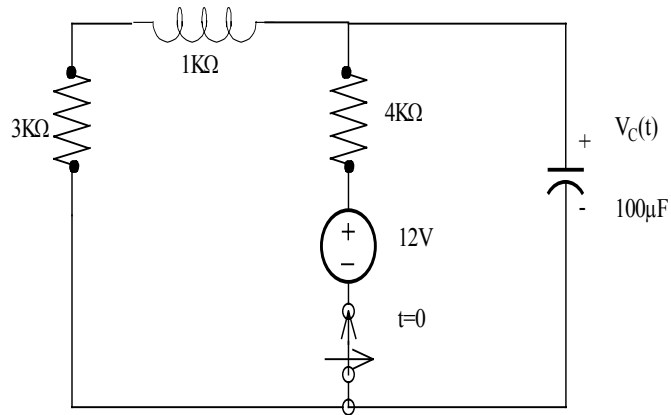

Suggested Solution

$$V_C(0^-) = 12 \left(\frac{4\text{K}}{8\text{K}} \right) = 6\text{V}$$

$$\frac{V_C(t)}{4\text{K}} + C d \frac{V_C(t)}{dt} = 0 \Rightarrow d \frac{V_C(t)}{dt} + \frac{V_C(t)}{0.4} = 0$$

$$\therefore V_C(t) = K_2 e^{-t/0.4} \text{V and since } V_C(0) = 6 = K_2$$

$$V_C(t) = 6e^{-t/0.4} \text{V } t > 0$$

Problem 6.4

Use the differential equation approach to find $i_0(t)$ for $t > 0$ in the network in Fig P6.4

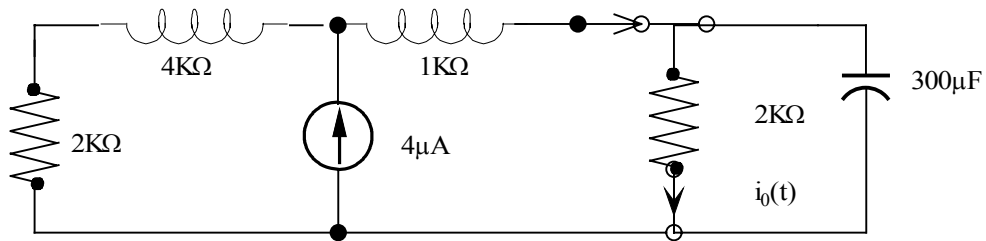

Suggested Solution

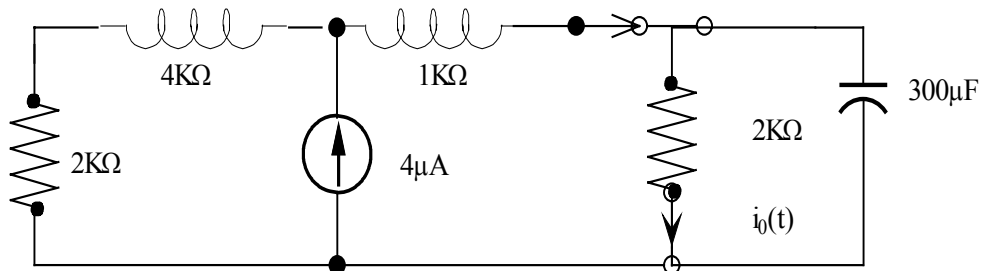

$$i_0(0^-) = \frac{6}{K} \left(\frac{6K}{9K} \right) = \frac{4}{K} A$$

$$V_c(0^-) = 2K \left(\frac{4}{K} \right) = 8V$$

$$\text{for } t > 0 \quad C \frac{dV_c(t)}{dt} + \frac{V_c(t)}{2K} = 0$$

$$\frac{dV_c(t)}{dt} + \frac{V_c(t)}{0.6} = 0$$

$$V_c(t) = K_2 e^{-t/0.6} V$$

$$V_c(t) = 8 = K_2 \quad \therefore V_c(t) = 8 e^{-t/0.6} V \quad t > 0$$

Problem 6.5

In the network in Fig P6.5, find $i_o(t)$ for $t > 0$ using the differential equation approach.

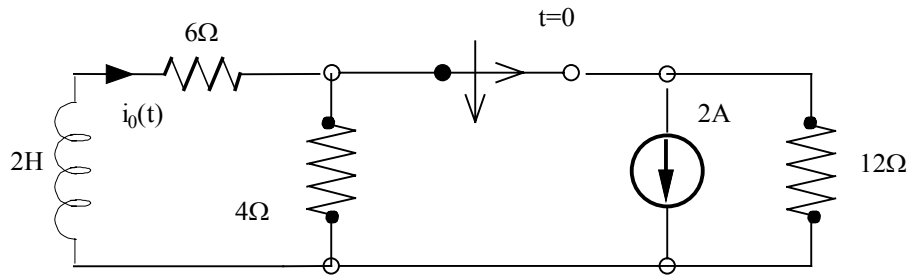

Suggested Solution

$$i_L(0^-) = 2 \left(\frac{3}{3+6} \right) = \frac{2}{3} \text{ A} \quad \text{using current division}$$

$$L \frac{di_o(t)}{dt} + 10i_o(t) = 0 \quad 10 = 6 + 4$$

$$\therefore i_o(t) = K_2 e^{-5t} \text{ A} \quad 5 = \frac{10}{L} = \frac{10}{2}$$

$$\text{So, } i_o(0) = \frac{2}{3} = K_2$$

$$\text{Then, } i_o(t) = \frac{2}{3} e^{-5t} \text{ A, } t > 0$$

Problem 6.6

In the circuit in Fig P6.6, find $i_0(t)$ for $t > 0$ using the differential equation approach.

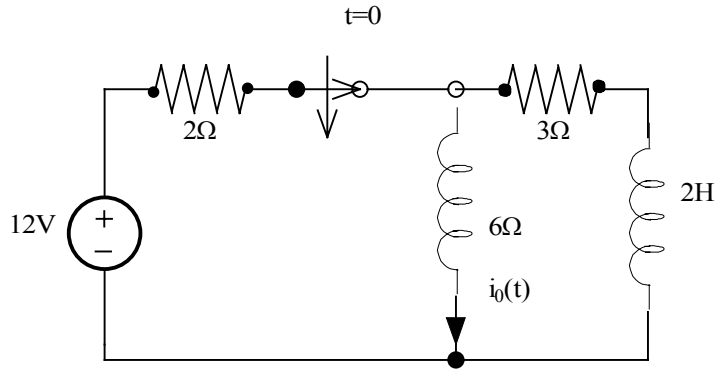

Suggested Solution

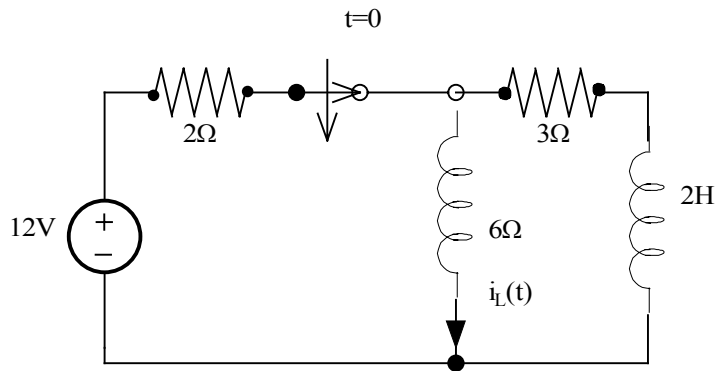

$$i_L(0^-) = \frac{12}{2 + 6/13} \left(\frac{6}{3+6} \right) = 2A$$

$$\text{for } t > 0L \frac{di_L(t)}{dt} + Ri_L(t) = 0 \text{ or } \frac{di_L(t)}{c(t)} + \frac{9}{2}i_L(t) = 0$$

$$i_L(t) = K_2 e^{-4.5t} A \quad i_L(0) = 2 = K_2$$

$$i_L(t) = 2e^{-4.5t} A \text{ but } i_0(t) = -i_L(t) = -2e^{-4.5t} A \quad t > 0$$

Problem 6.7

Use the differential equation approach to find $V_0(t)$ for $t > 0$ in the circuit in Fig P6 and plot the response including the time interval just prior to switch action.

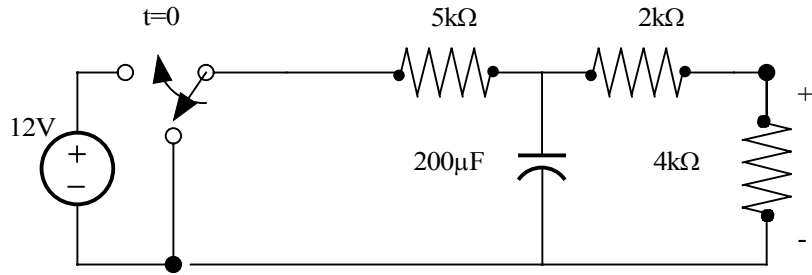

Suggested Solution

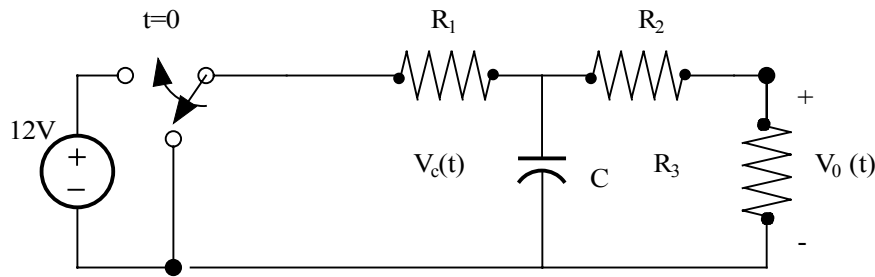

For $t < 0$, $V_C(0^-) = V_C(0^+) = 0$ and $V_0(0^-) = 0V$

$$R_1 = 5K\Omega \quad R_2 = 2K\Omega$$

$$R_3 = 4K\Omega \quad C = 0.2mF$$

For $t \geq 0$

$$V_C(0^+) = 0V \quad V_0(0^+)R_3 = 0V$$

$$\text{By KCL: } \frac{12 - V_2}{R_1} = \frac{V_2}{R_2 + R_3} + C \frac{dV_2}{dt}$$

$$\text{By KVL: } V_0(t) = V_2 \left(\frac{R_3}{R_2 + R_3} \right) \quad 12 = V_2 \left[1 + \frac{R_1}{R_2 + R_3} \right] + R_3 C \frac{dV_2}{dt}$$

$$\text{or } V_2 = 1.5 V_0(t) \Rightarrow \frac{dV_0}{dt} + \frac{11}{6} V_0 - 8 = 0 \quad \text{Eq.1}$$

Assume,

$$V_0(t) = K_1 + K_2 e^{-\frac{t}{6}} - 8 = 0 \Rightarrow \{K_1 = \frac{48}{11} \text{ V}$$

$$\text{Now, } V_0(t) = \frac{48}{11} + K_2 e^{-\frac{t}{6}} \text{ V}$$

$$V_0(0^+) = 0 = \frac{48}{11} + K_2 \Rightarrow K_2 = \frac{-48}{11}$$

$$V_0(t) = \frac{48}{11} (1 - e^{-\frac{t}{6}}) \text{ V } \quad t > 0 \quad \text{and } V_0(t) = 0 \quad t < 0$$

Problem 6.8

Use the differential equation approach to find $i(t)$ for $t > 0$ in the circuit in Fig. P8 and plot the response including the time interval just prior to opening the switch.

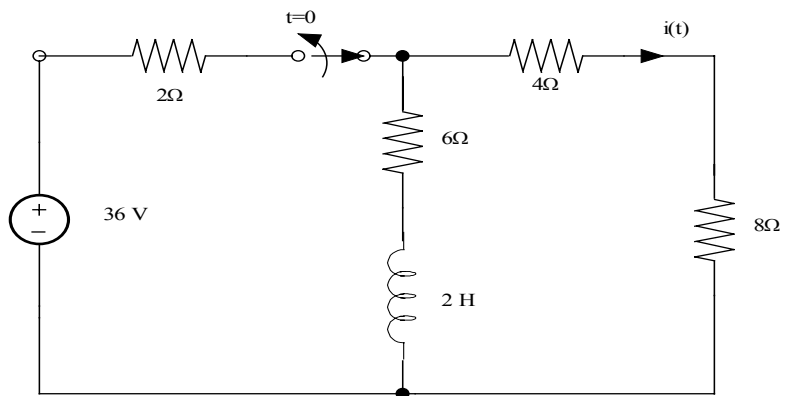

Suggested Solution

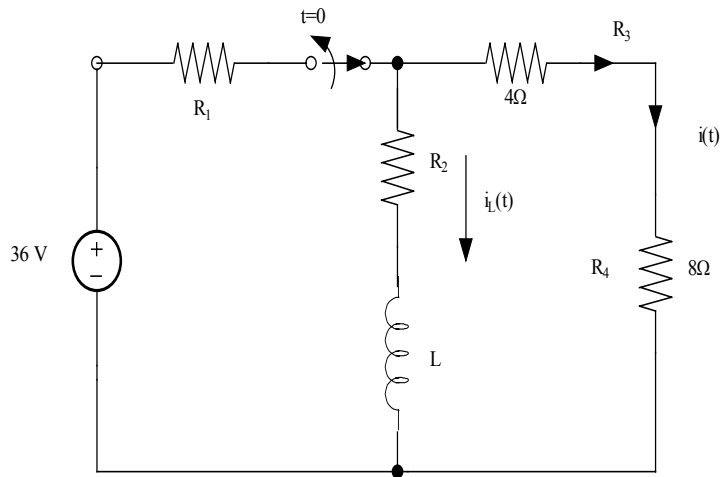

$$R_1 = 2\Omega$$

For $t < 0$

$$R_2 = 6\Omega$$

$$i_L(0^-) = i_L(0^+) = 4A$$

$$R_3 = 4\Omega$$

$$i(0^-) = 2A$$

$$R_4 = 8\Omega$$

$$L = 2H$$

By KVL: $i(t)[R_2 + R_3 + R_4] + L \frac{di(t)}{dt} = 0$

or, $\frac{di(t)}{dt} + 9i(t) = 0$

Assume $i(t) = K_1 + K_2 e^{-t}$

Now, $-\frac{K_2}{9} e^{-t} + 9K_1 + 9K_2 e^{-t} = 0$

So, $K_1 = 0A$ and $\tau = \frac{1}{9}$ sec. Also, $i(0^+) = LK_1 + K_2 = -4 \Rightarrow K_2 = -4$

$$i(t) = -4e^{-9t} \quad t > 0$$

$$i(t) = 2 \quad t < 0$$

Problem 6.9

Use the differential equation approach to find $v_c(t)$ for $t > 0$ in the circuit in Fig P6.9 and plot the response including the time interval just prior to opening the switch.

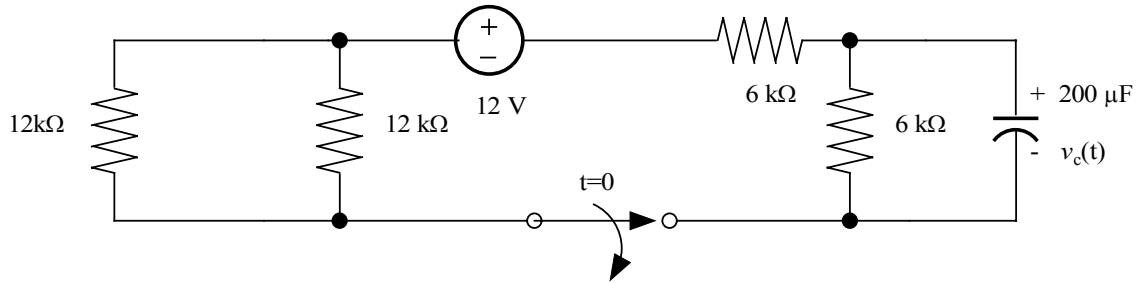

Suggested Solution

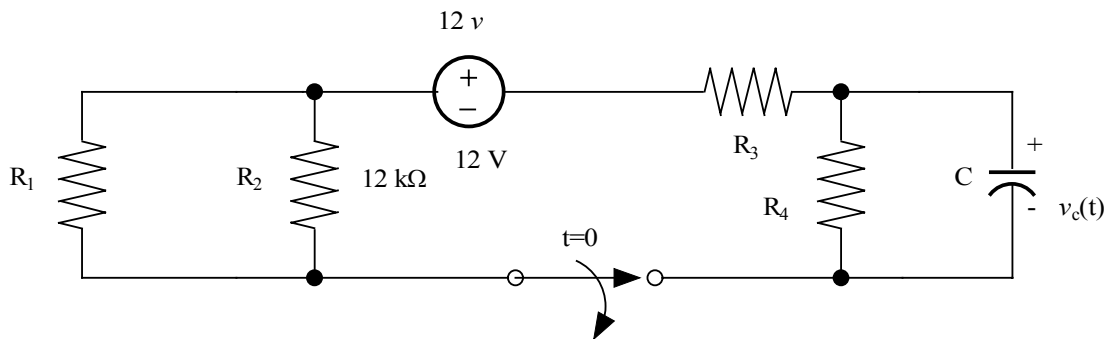

Problem 6.10

Use the differential equation approach to find $i_L(t)$ for $t > 0$ in the circuit in Fig. P6.10 and plot the response including the time interval just prior to opening the switch.

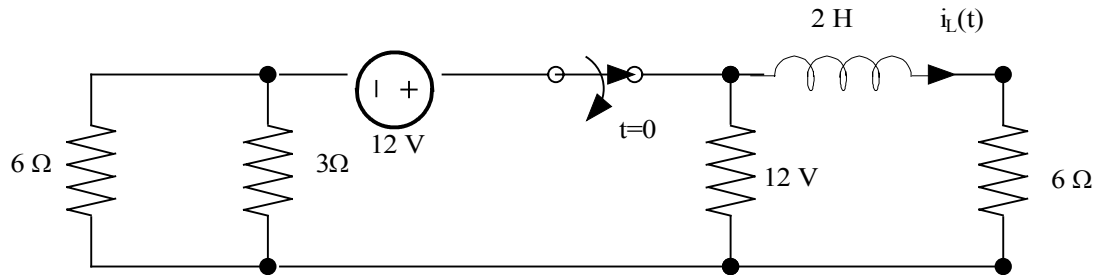

Suggested Solution

Problem 6.11

Use the differential equation approach to find $i(t)$ for $t > 0$ in the circuit in Fig. P6.4 and plot the response including the time interval just prior to switch movement.

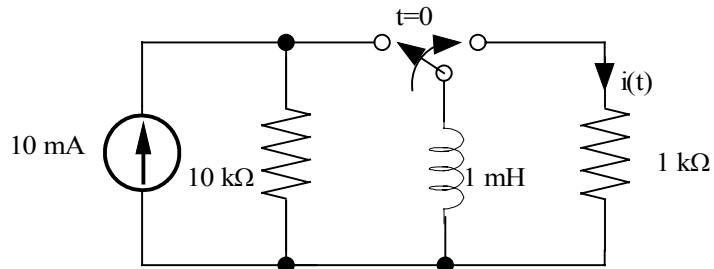

Suggested Solution

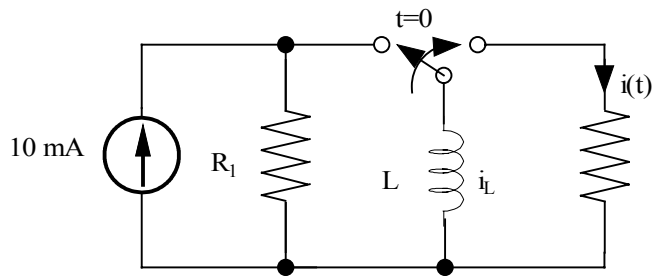

$$R_1 = 10k\Omega$$

$$R_2 = 1k\Omega$$

$$L = 1mH$$

At $t=0^-$ and $t=0^+$

$$i_L(0^-) = i_L(0^+) = 10\text{ mA}$$

$$i(0^-) = 0\text{ A}$$

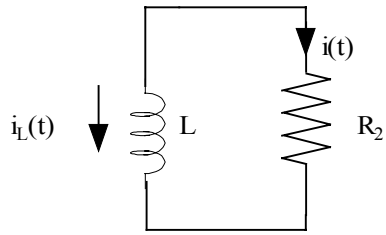

$$i_L(0^+) = -i_L(0^-) = -10\text{mA}$$

By KVL: $R_2 i(t) + L \frac{di(t)}{dt} = 0$

or, $\frac{di(t)}{dt} + \frac{R_2}{L} i(t) = 0$

Assuming $i(t) = K_1 + K_2 e^{\frac{t}{\tau}}$

$$\text{Now, } -\frac{K_2}{\tau} e^{\frac{t}{\tau}} + \frac{R_2 K_1}{L} + \frac{R_2 K_2}{L} e^{\frac{t}{\tau}} = 0 \Rightarrow \begin{cases} K_1 = 0 \\ \tau = \frac{L}{R_2} = 0.1\mu\text{s} \end{cases}$$

$$i(t) = -10e^{-10^7 t} \text{ mA} \quad t > 0 \quad \text{and} \quad i(t) = 0 \quad t < 0$$

Problem 6.12

Use the differential equation approach to find $V_C(t)$ for $t > 0$ in the circuit in Fig. P6.12 and plot the response including the time interval just prior to closing the switch.

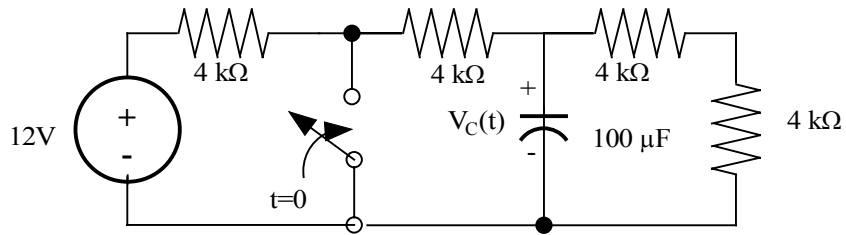

Suggested Solution

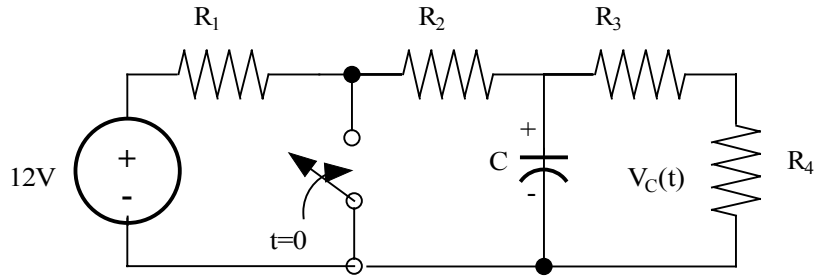

All $R=4k\Omega$ $V_C(0^-) = V_C(0^+) = 12 \left[\frac{R_3 + R_4}{R_1 + R_2 + R_3 + R_4} \right]$

$C = 0.1 \text{ mF}$

$V_C(0) = 6V$

For $t > 0$ By KCL: $\frac{V_C(t)}{\frac{8}{3}k} + C \frac{dV_C(t)}{dt} = 0$

$\frac{dV_C(t)}{dt} + \frac{15}{4}V_C(t) = 0$

Assume, $V_C(t) = K_1 + K_2 e^{-\frac{t}{\tau}}$

$\frac{-K_2}{\tau} e^{-\frac{t}{\tau}} + \frac{15}{4}K_1 + \frac{15}{4}K_2 e^{-\frac{t}{\tau}} = 0$

$K_1 = 0$ $\tau = \frac{4}{15} \text{ sec.}$

Now,

$V_C(t) = K_2 e^{-\frac{t}{\tau}}$ $V_C(0^+) = K_2 = 6$ so,

$V_C(t) = 6e^{-\frac{15t}{4}}$ v for $t > 0$ $V_C(t) = 6$ for $t < 0$

Problem 6.13

Use the differential equation approach to find $V_c(t)$ for $t > 0$ in the circuit in Fig. P.13 and plot the response including the time interval just prior to opening the switch.

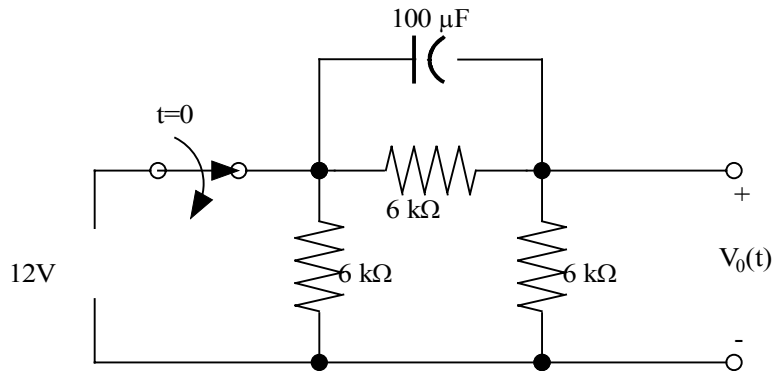

Suggested Solution

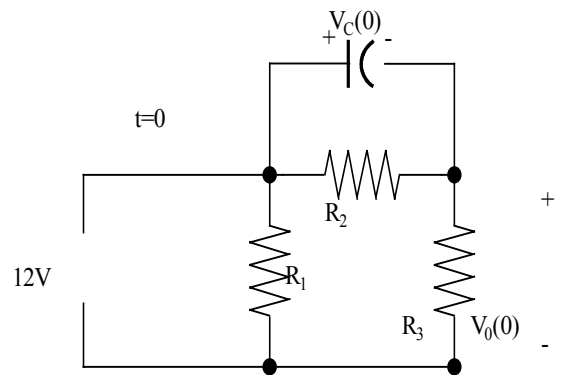
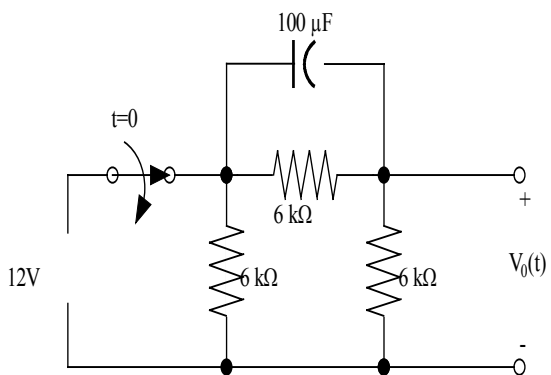

$$R_1 = 6k\Omega$$

For $t < 0$

$$R_2 = 6k\Omega$$

$$V_C(0^-) = V_C(0^+)$$

$$R_3 = 6k\Omega$$

$$V_C = 12 \left[\frac{R_2}{R_2 + R_3} \right]$$

$$C = 0.1mF$$

$$V_C(0) = 6V$$

$$V_C(0^-) = 6V$$

At $t > 0$

By KCL:
$$C \frac{dV_C}{dt} + \frac{V_C}{R_2} + \frac{V_C}{R_1 + R_3} = 0$$

or,
$$\frac{dV_C(t)}{dt} + 2.5V_C(t) = 0$$

Assuming $V_C(t) = K_1 + K_2 e^{-\frac{t}{\tau}}$, we find

$$-K_2 e^{-\frac{t}{\tau}} + 2.5K_1 + 2.5K_2 e^{-\frac{t}{\tau}} = 0 \Rightarrow K_1 = 0 \text{ and } \tau = 0.45$$

$$V_C(0^+) = 6V = K_2 e^0 = K_2 \text{ so } V_C(t) = 6e^{-2.5t} V$$

But,
$$V_0(t) = -V_C(t) \frac{[R_3]}{R_1 + R_3} \text{ so, } V_0(t) = -3e^{-2.5t} V \quad t \geq 0$$

$$V_0(t) = 6V \quad t < 0$$

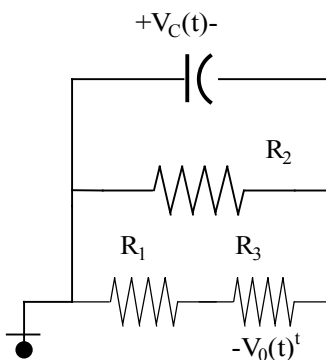

Problem 6.14

Use the differential equation approach to find $i_0(t)$ for $t > 0$ in the circuit in Fig. P6.14 and plot the response including the time interval just prior to closing the switch.

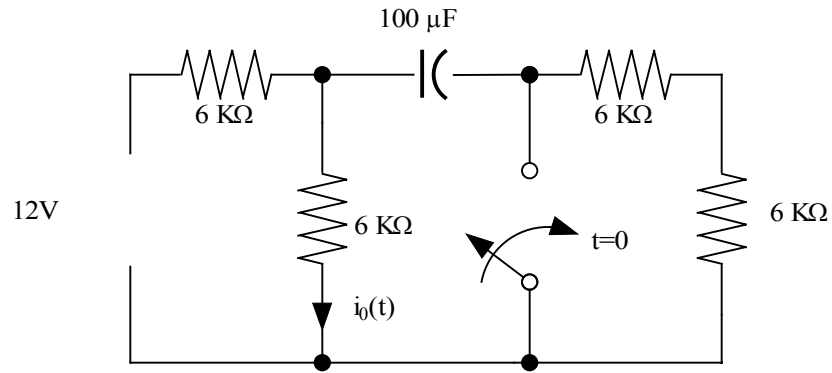

Suggested Solution

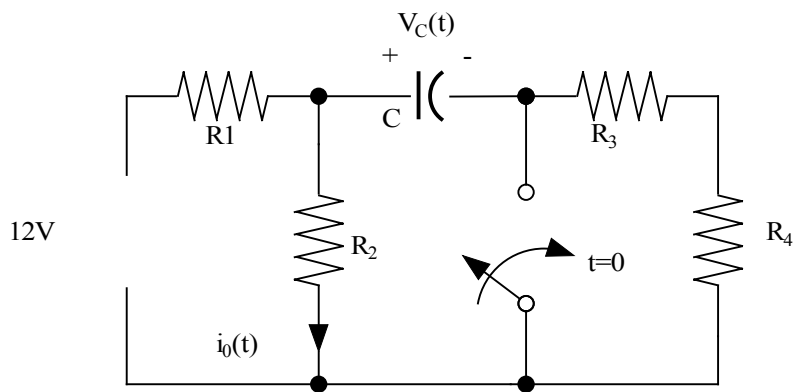

All $R = 6K\Omega$

For $t < 0$

$C = 0.1mF$

$$i_0(0^-) = \frac{12}{R_1 + R_2} = 1mA$$

$$\begin{aligned} V_C(0^-) &= V_C(0^+) \\ &= i_0(0^-)R_2 \\ &= 6V \end{aligned}$$

For $t > 0$

$$\text{KCL: } \frac{12 - V_C(t)}{R_1} = \frac{V_C(t)}{R_2} + C \frac{dV_C(t)}{dt}$$

$$\text{or, } \frac{dV_C(t)}{dt} + \frac{10}{3} V_C(t) = 20$$

$$\text{Assume } V_C(t) = K_1 + K_2 e^{\frac{-t}{\tau}}. \text{ Now, } \frac{-K_2 e^{\frac{-t}{\tau}}}{\tau} + \frac{10K_1}{3} + \frac{10K_2 e^{\frac{-t}{\tau}}}{3} = 20$$

So, $\tau = 0.3 \text{ s}$ and $K_1 = 6$. Yields $V_C(t) = 6 + K_2 e^{\frac{-t}{\tau}}$

But $V_C(0^+) = 6 = 6 + K_2 e^0 = 6 + K_2 \Rightarrow K_2 = 0!$

$$V_C(t) = 6V.$$

Note that $i_0(t) = \frac{V_C(t)}{R_2} = 1mA$

$$\boxed{i_0(t) = 1mA \text{ for all } t}$$

Problem 6.15

Use the differential equation approach to find $i(t)$ for $t > 0$ in the circuit in Fig. P.16 and plot the response including the time interval just prior to switch movement.

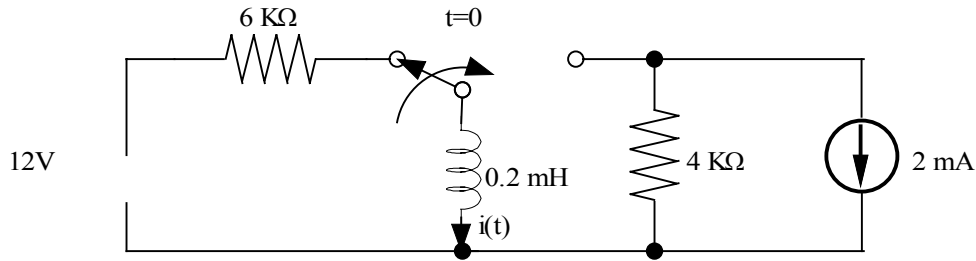

Suggested Solution

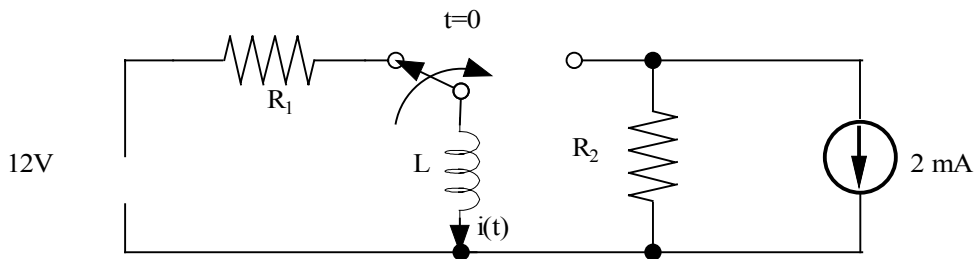

$$R_1 = 6\text{ k}\Omega$$

when $t < 0$,

$$R_2 = 4\text{ k}\Omega \quad i(0^-) = i(0^+) = \frac{12}{R_1} = 2\text{ mA}$$

$$L = 0.2\text{ mH}$$

For $t > 0$ KVL: $L \frac{di_1(t)}{dt} + R_2(i_1 - i_2) = 0$ and $i_2 = 2\text{ mA}$

$$\frac{di_1(t)}{dt} + \frac{R_2}{L} i_1 = \frac{R_2}{L} i_2$$

Assume $i_1(t) = K_1 + K_2 e^{\frac{t}{\tau}}$, now, $\frac{-K_2}{\tau} e^{\frac{t}{\tau}} + \frac{R_2}{L} K_1 + \frac{R_2}{L} K_2 e^{\frac{t}{\tau}} = \frac{R_2}{L} i_2$

yields $\tau = \frac{L}{R_2} = 50\text{ ns}$ and $K_1 = 2\text{ mA}$.

$i_1(0) = -i(0) = -2\text{ mA} = K_1 + K_2 \Rightarrow K_2 = -4\text{ mA}$. Also, $i(t) = -i_1(t)$

$$i(t) = (4e^{-2 \times 10^6 t} - 2)\text{ mA for } t \geq 0 \text{ and } i(t) = 2\text{ mA } t < 0$$

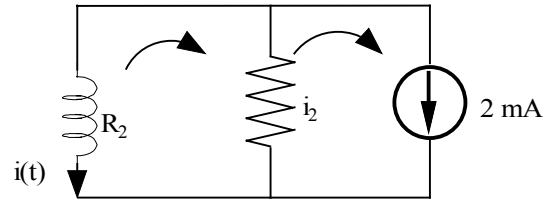

Problem 6.16

Use the differential equation approach to find $V_0(t)$ for $t > 0$ in the circuit in Fig. P.16 and plot the response including the time interval just prior to switch action.

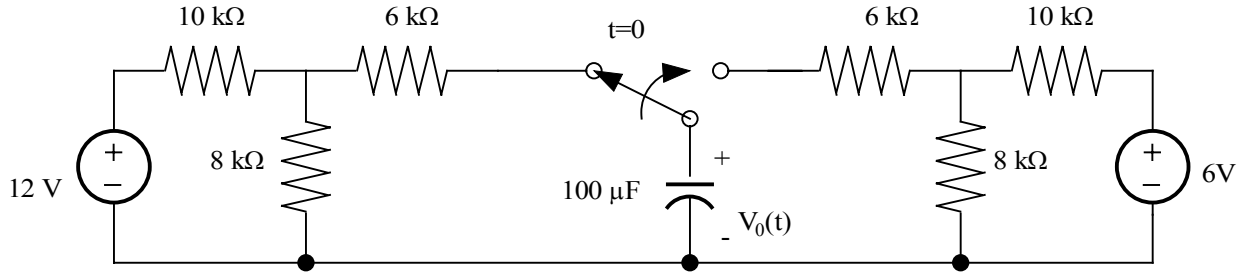

Suggested Solution

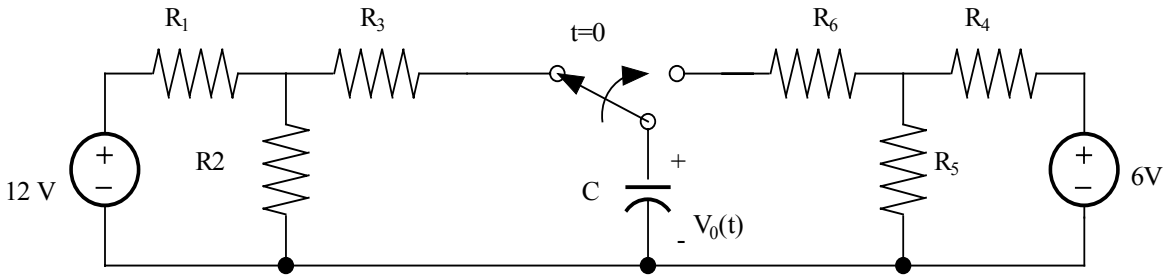

$$\begin{aligned}
 R_1 &= R_4 = 10\text{k}\Omega & C &= 0.1\text{mF} \\
 R_2 &= R_5 = 8\text{k}\Omega \\
 R_3 &= R_6 = 6\text{k}\Omega
 \end{aligned}$$

Perform 2 Thevenin equivalents, one at each side of the switch,

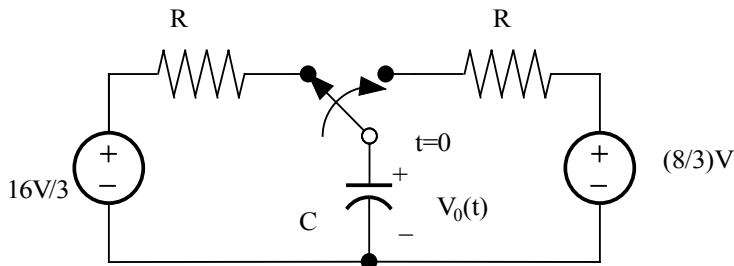

For $t > 0$

$$R = \frac{94}{9} k\Omega$$

$$\text{By KCL: } \frac{\frac{8}{3} - V_0}{R} = C \frac{dV_0}{dt}$$

$$\text{Assume, } V_0(t) = K_1 + K_2 e^{-\frac{t}{\tau}}$$

$$\text{Now, } \frac{8}{3} - K_1 - K_2 e^{-\frac{t}{\tau}} = -\left(\frac{9.4K_2}{9\tau}\right) e^{-\frac{t}{\tau}} \Rightarrow K_1 = \frac{8}{3} \text{ and } \tau = \frac{9.4}{9}$$

$$V_0(0^+) = \frac{16}{3} = K_1 + K_2 \Rightarrow K_2 = \frac{8}{3}$$

$$\boxed{\begin{array}{l} V_0(t) = 8[1 - e^{-0.96t}] V, \quad t \geq 0 \\ V_0(t) = \frac{16}{3} \quad V, \quad t < 0 \end{array}}$$

Problem 6.17

Use the differential equation approach to find $V_0(t)$ for $t > 0$ in the circuit in Fig. P.17 and plot the response including the time interval just prior to closing the switch.

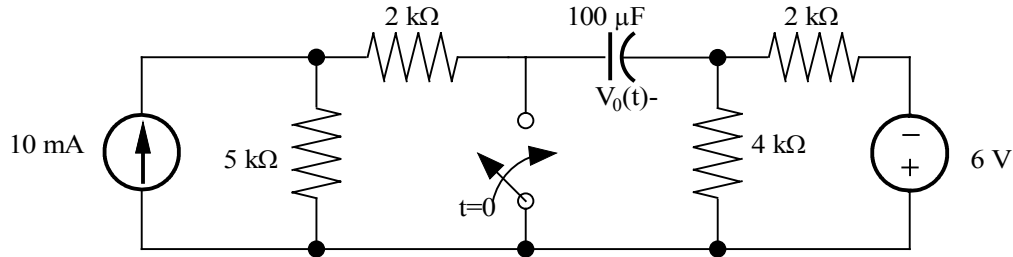

Suggested Solution

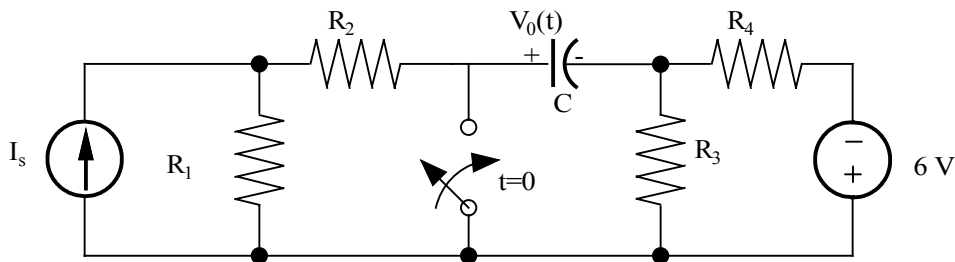

$R_1 = 5\text{k}\Omega$	$R_3 = 4\text{k}\Omega$	$C = 0.1\text{ mF}$
$R_2 = 2\text{k}\Omega$	$R_4 = 2\text{k}\Omega$	$I_s = 10\text{ mA}$

Perform 2 Thevenin equivalents—one at each side (left/right) of the switch.

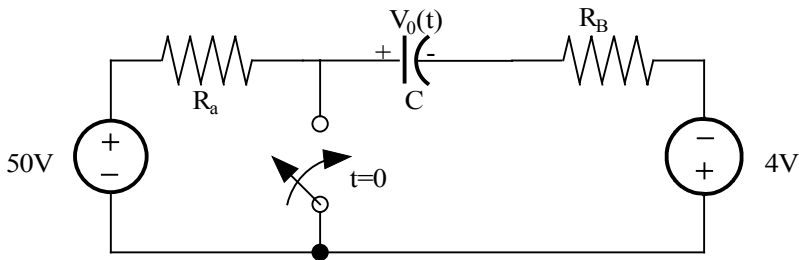

$$R_a = 7\text{k}\Omega$$

$$R_B = 4/3\text{ k}\Omega$$

For $t < 0$
No current flow,
 $V_0(0^-) = V_0(0^+) = 54\text{V}$

For $t > 0$

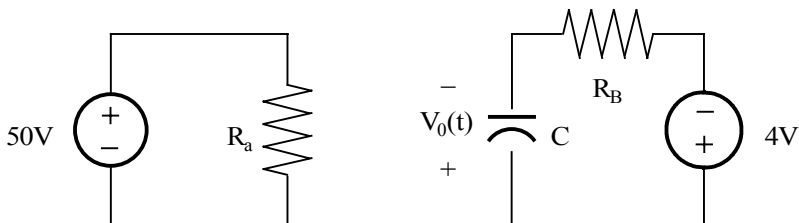

By KCL: $C \frac{dV_0}{dt} + \frac{-4-V_0(t)}{R_B} = 0$

or, $\frac{dV_0}{dt} - 7.5V_0(t) = 30$

If $V_0(t) = K_1 + K_2 e^{\frac{-t}{\tau}}$, $-K_2 e^{\frac{-t}{\tau}} - 7.5K_1 - 7.5K_2 e^{\frac{-t}{\tau}} = 30$

yields, $\tau = \frac{1}{7.5}$ and $K_1 = -4$. Nor, $V_0(0^+) = 54 = K_1 + K_2 \Rightarrow K_2 = 58$

$V_0(t) = -4 + 58e^{-7.5t} V$	$t \geq 0$
$= 54V$	$t < 0$

Problem 6.18

Use the differential equation approach to find $V_0(t)$ for $t > 0$ in the circuit in Fig. P6.18 and plot the response including the time interval just prior to opening the switch.

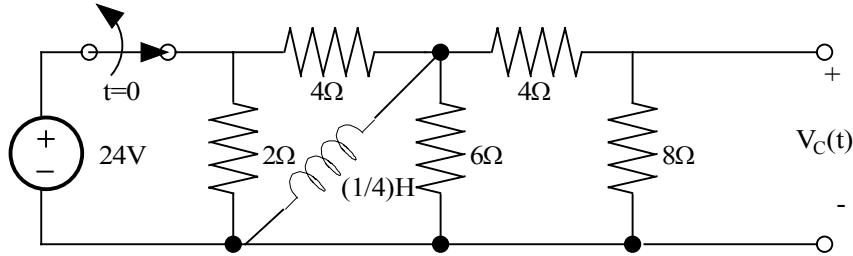

Suggested Solution

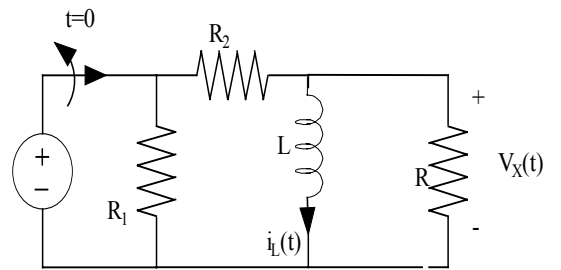
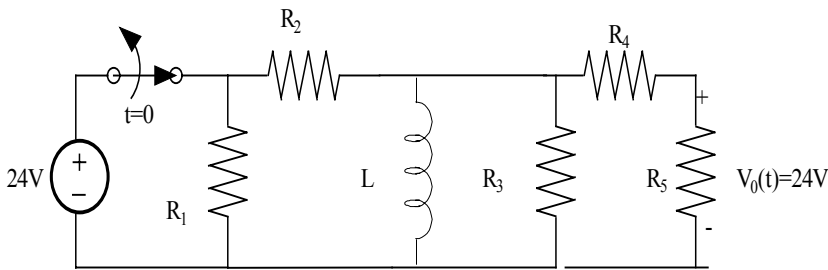

$$R_1 = 2\Omega \quad R_2 = R_4 + 4\Omega \quad R_3 = 6\Omega \quad R_5 = 8\Omega \quad L = \frac{1}{4}H \quad R = 4\Omega \quad V_0 = \frac{2^u x}{3}$$

At $t < 0$: $i_L(0^-) = i_L(0^+) = \frac{24}{R_2} = 6A$ and $V_x(0^-) = 0$

At $t > 0$ KVL: $\frac{L di_L}{dt} + R_x i_L = 0 \Rightarrow \frac{di_L}{dt} + 9.6 i_L = 0$

If $i_L(t) = K_1 + K_2 e^{\frac{-t}{\tau}}$, then $\tau = \frac{1}{9.6} S$ and $K_1 = 0$

$$i_L(0^+) = 6 = K_2 \Rightarrow i_L(t) = 6e^{-9.6t} A$$

$$R_x = R // (R_1 + R_2)$$

$$V_x(t) = -R_x i_L(t) = -1.4e^{-9.6t} V$$

$$R_x = 2.4\Omega$$

$$\begin{aligned} V_0(t) &= -9.6e^{-9.6t} V & t > 0 \\ &= 0 & t < 0 \end{aligned}$$

Problem 6.19

Use the differential equation approach to find $V_0(t)$ for $t > 0$ in the circuit in Fig. P.19 and plot the response including the time interval just prior to opening the switch.

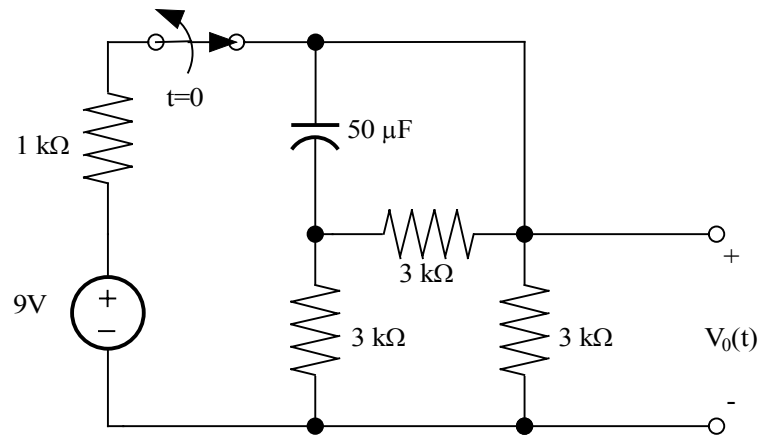

Suggested Solution

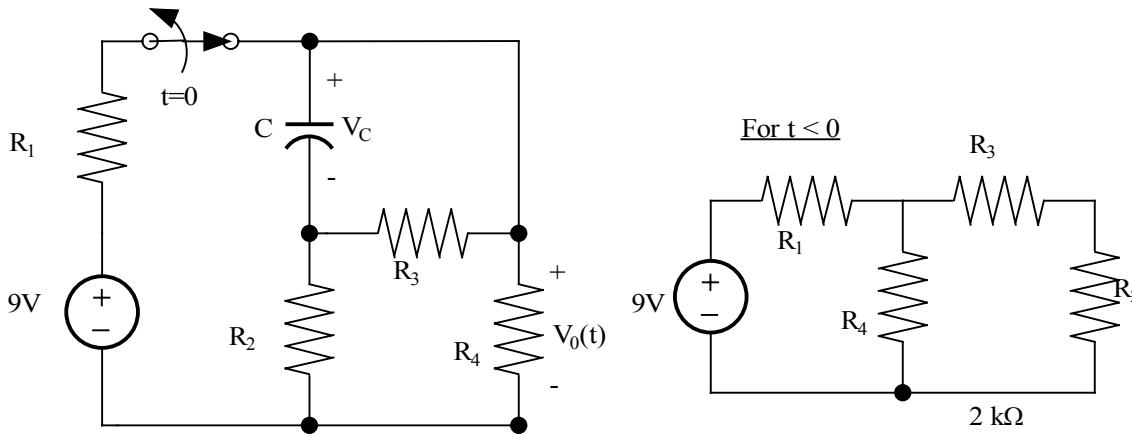

$$V_0(0^-) = 9 \left(\frac{2K}{2K + R_1} \right) = 6V$$

$$V_C(0^-) = V_0(0^-) \left(\frac{R_2}{R_2 + R_3} \right) = 3V$$

$$V_C(0^+) = V_C(0^-)$$

For $t > 0$

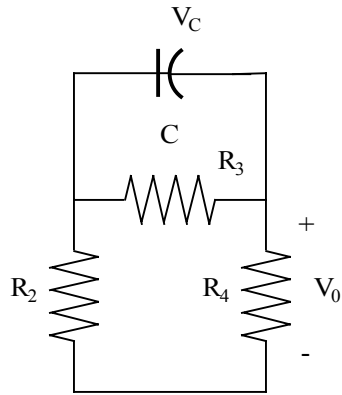

$$\text{KCL: } C \frac{dV_C}{dt} + \frac{V_C}{R_3} + \frac{V_C}{R_2 + R_4} = 0 \Rightarrow \frac{dV_C}{dt} + 10 V_C = 0$$

$$\text{If } V_C(t) = K_1 + K_2 e^{\frac{t}{\tau}},$$

$$\frac{-K_2}{\tau} e^{\frac{t}{\tau}} + 10K_1 + 10K_2 e^{\frac{t}{\tau}} + 0 \Rightarrow \tau = 0.15, K_1 = 0$$

$$V_C(0^+) = 3 = K_2 \Rightarrow V_C(t) = 3e^{-10t} V$$

$$V_0 = -V_C \left(\frac{R_4}{R_4 + R_2} \right)$$

$$V_0 = -\frac{V_C}{2}$$

$V_0(t) = -1.5e^{-10t} V$	$t > 0$
$= 6V$	$t < 0$

Problem 6.20

Use the differential equation approach to find $i_0(t)$ for $t > 0$ in the circuit in Fig. P.20 and plot the response including the time interval just prior to opening the switch.

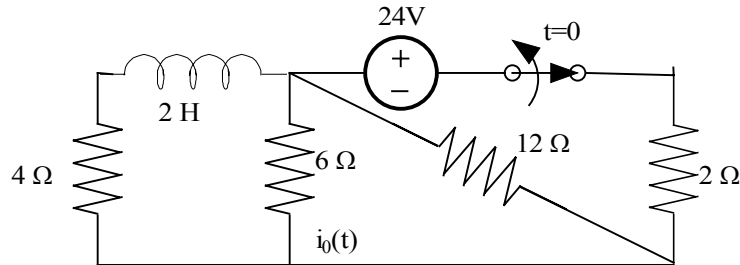

Suggested Solution

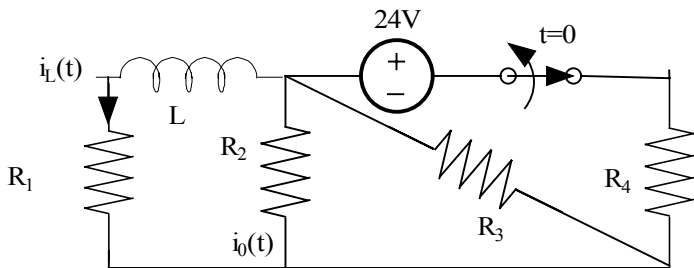

For $t < 0$

- $R_1 = 4\Omega$
- $R_2 = 6\Omega$
- $R_3 = 12\Omega$
- $R_4 = 2\Omega$
- $R_5 = 2\Omega$
- $L = 2\text{H}$

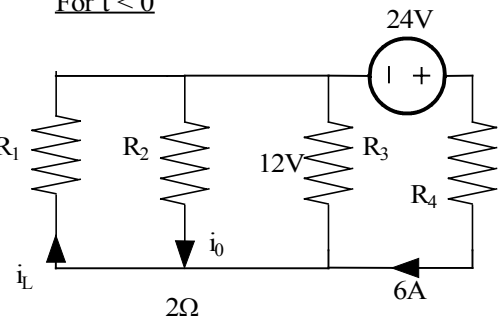

$$i_0(0^-) = \frac{-12}{R_2}$$

$$i_0(0^-) = -2\text{ A}$$

$$i_L(0^-) = i_L(0^+) = \frac{12}{R_1} = 3\text{ A}$$

For $t > 0$

$$\text{KVL: } \frac{L di_x}{dt} + (R + R_1)i_x(t) = 0$$

$$\text{or, } \frac{di_x}{dt}(t) + 4i_x(t) = 0$$

$$\text{If } i_x(t) = K_1 + K_2 e^{\frac{-t}{\tau}}, \frac{-K_2 e^{\frac{-t}{\tau}}}{\tau} + 4K_1 + 4K_2 e^{\frac{-t}{\tau}} = 0$$

$$R = R_2 // R_3 = 4\Omega$$

$$i_0(t) = \frac{i_x(t)R_3}{R_2 + R_3} = \frac{2i_x}{3}$$

yields, $\tau = 0.25$ sec. and $K_1 = 0$

$$i_x(t) = K_2 e^{-4t} \text{ and } i_x(0^+) = K_2 = i_L(0^+) = 3A$$

$i_0(t) = 2e^{-4t} A, t \geq 0$
$i_0(t) = -2 A, \tau < 0$

Problem 6.21

Use the differential equation approach to find $i_0(t)$ for $t > 0$ in the circuit in Fig. P.21 and plot the response including the time interval just prior opening the switch.

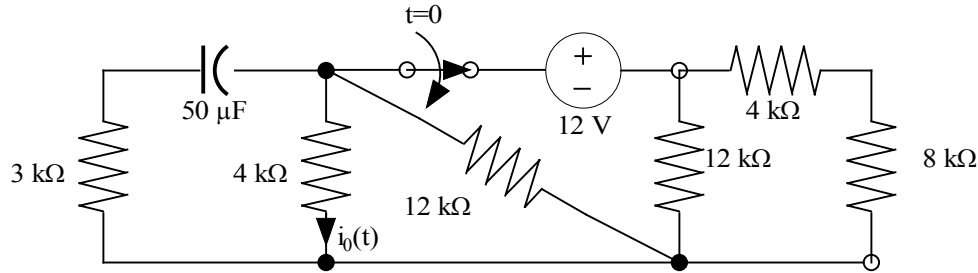

Suggested Solution

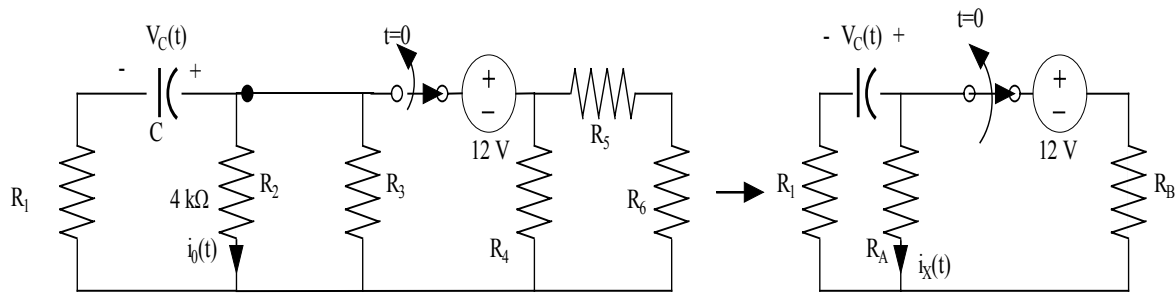

$$R_1 = 3 \text{ k}\Omega \quad R_2 = R_5 = 4 \text{ k}\Omega \quad R_3 = R_4 = 12 \text{ k}\Omega \quad R_6 = 8 \text{ k}\Omega \quad C = 0.05 \text{ mF} \quad R_A = 3 \text{ k}\Omega \quad R_B = 6 \text{ k}\Omega$$

For $t < 0$: $V_C(t) = \frac{-12R_A}{(R_A + R_B)} = -4 \text{ V} = V_C(0^-) = V_C(0^+)$

$$i_X(0^-) = \frac{V_C(0^-)}{R_A} = \frac{-4}{3} \text{ mA} \quad i_0(0^-) = \frac{i_X(0^-)R_3}{(R_2 + R_3)} = -1 \text{ mA}$$

For $t > 0$: By KCL: $\frac{C \, dV_C(t)}{dt} + \frac{V_C(t)}{R_1 + R_A} = 0 \Rightarrow \frac{dV_C}{dt} + \frac{10}{3} = 0$

For $t > 0$

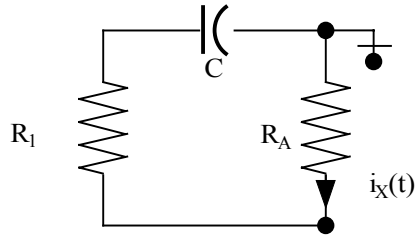

If $V_C(t) = K_1 + K_2 e^{-\frac{t}{\tau}}$, then $\tau = 0.3 \text{ S}$ and $K_1 = 0$

$V_C(0^+) = K_2 = -4 \text{ V}$ so, $V_C(t) = -4 e^{-\frac{10t}{3}} \text{ V}$

But $i_x(t) = \frac{-V_C(t)}{R_1 + R_A}$ and $i_0(t) = \frac{i_x(t)R_3}{R_2 + R_3} \Rightarrow$

$i_0(t) = 0.5 e^{-\frac{10t}{3}} \text{ mA}, t > 0$ $= 1 \text{ mA}, t < 0$

Problem 6.22

Use the differential equation approach to find $i_0(t)$ for $t > 0$ in the circuit in Fig. P.22 and plot the response including the time interval just prior to opening the switch.

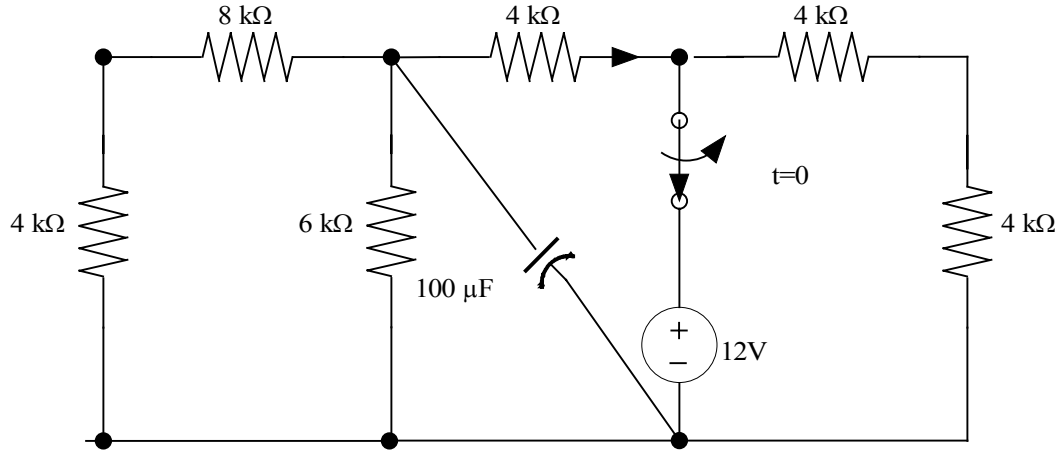

Suggested Solution

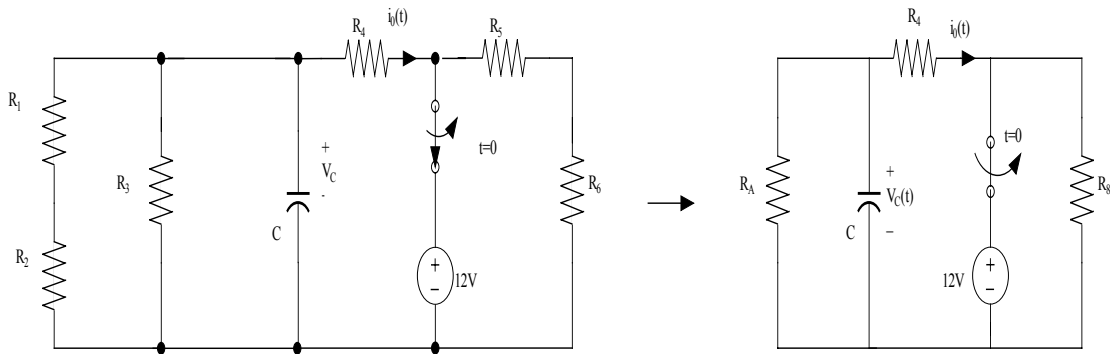

$$R_1 = 8 \text{ k}\Omega \quad R_2 = R_4 = R_5 = R_6 = 4 \text{ k}\Omega \quad R_3 = 6 \text{ k}\Omega \quad C = 0.1 \text{ mF} \quad R_A = 4 \text{ k}\Omega \quad R_B = 8 \text{ k}\Omega$$

$$\text{For } t < 0: \quad V_C(0^-) = V_C(0^+) = \frac{12R_A}{(R_A + R_4)} = 6\text{V} \quad i_0(0^-) = -1.5 \text{ mA}$$

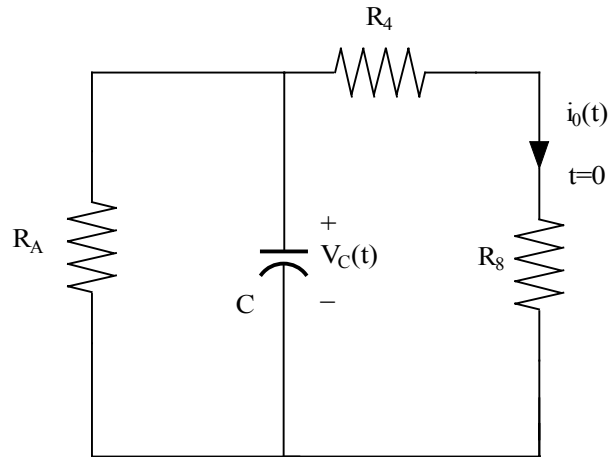

$$\text{KCL: } \frac{C dV_C}{dt} + \frac{V_C}{R_A} + \frac{V_C}{R_4 + R_B} = 0 \Rightarrow \frac{dV_C}{dt} + \frac{10}{3} V_C = 0$$

$$\text{If } V_C(t) = K_1 + K_2 e^{\frac{t}{\tau}}, \tau = 0.3\text{s and } K_1 = 0$$

$$V_C(0^+) = 6 = K_2 \text{ So, } \boxed{\begin{array}{l} i_0(t) = 0.5e^{\frac{-10t}{3}} \text{ mA, } t > 0 \\ = -1.5 \text{ mA, } t < 0 \end{array}}$$

Problem 6.23

Use the differential equation approach to find $i_0(t)$ for $t > 0$ in the circuit in Fig. P.23 and plot the response including the time interval just prior to opening the switch.

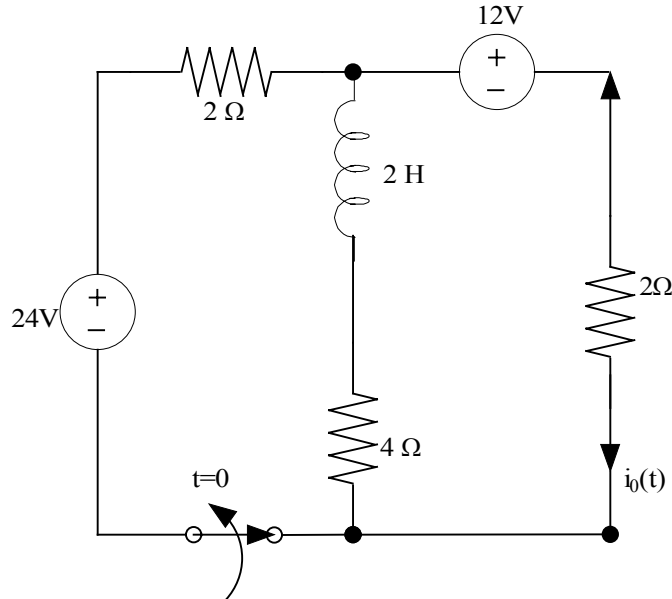

Suggested Solution

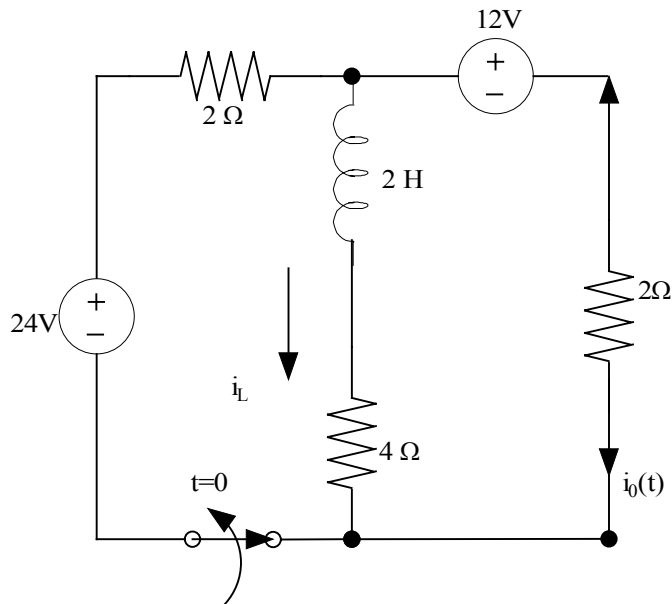

For $t=0^-$ Use superposition

$$i_L = \frac{24}{2+(4/2)} \left(\frac{2}{2+4} \right) - \frac{12}{2+(4/2)} \left(\frac{2}{2+4} \right) = 1.2A$$

$$i_0 = \frac{24}{2+(4/2)} \left(\frac{4}{2+4} \right) + \left(\frac{12}{2+(4/2)} \right) = 8.4A$$

For $t=0^+$: $i_0 = -L = -L(0^-) = 1.2A$

$$12 = 6 i_0(t) + 2 \frac{di_0(t)}{dt} \quad \text{so, } i_0(t) = K_1 + K_2 e^{-\frac{t}{\tau}}$$

Now, $12=6K_1+6K_2e^{\frac{t}{\tau}}+\left(\frac{-2K_2}{\tau}\right)e^{\frac{-t}{\tau}} \Rightarrow K_1=\frac{12}{6}=2$ and $\frac{1}{\tau}=3$

$i_0(0^+)=-1.2=K_1+K_2 \Rightarrow K_2=-3.2$

$$i_0(t)=\begin{cases} -1.2A & t < 0 \\ 2-3.2e^{-3t}A & t > 0 \end{cases}$$

Problem 6.24

Use the differential equation approach to find $V_0(t)$ for $t > 0$ in the circuit in Fig. P.24 and plot the response including the time interval just prior to opening the switch.

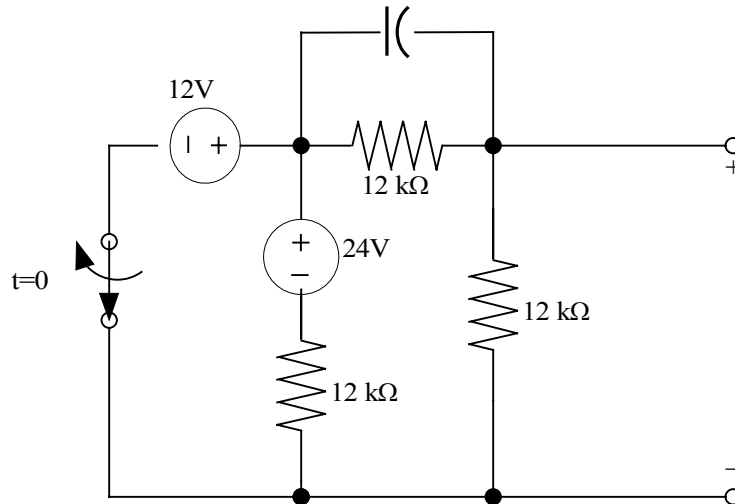

Suggested Solution

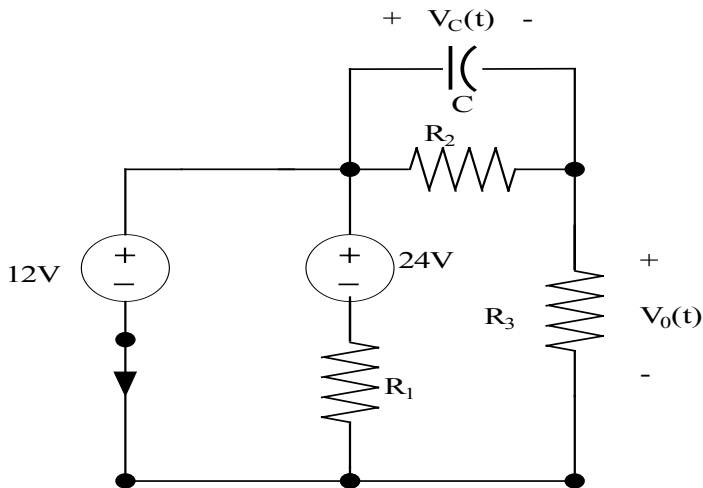

All $R=12\text{ k}\Omega$ $C=0.1\text{ mF}$

For $t < 0$

$$V_C(0^-) = V_C(0^+) = 12 \left(\frac{R_2}{R_2 + R_3} \right) = 6V$$

$$V_0(0^-) = 12 - V_C(0^-) = 6V$$

For $t > 0$

KCL:

$$C \frac{d}{dt} \left(\frac{V_1 + 24}{1.2} \right) + 1(V_1 + 24) = \frac{V_0}{R_3}$$

$$\text{or, } \frac{dV_1}{dt} + \frac{V_1}{1.2} + 20 = \frac{V_0}{1.2}$$

$$\text{Also, } \frac{V_1}{R_1} + \frac{V_0}{R_3} = 0 \Rightarrow V_1 = -V_0$$

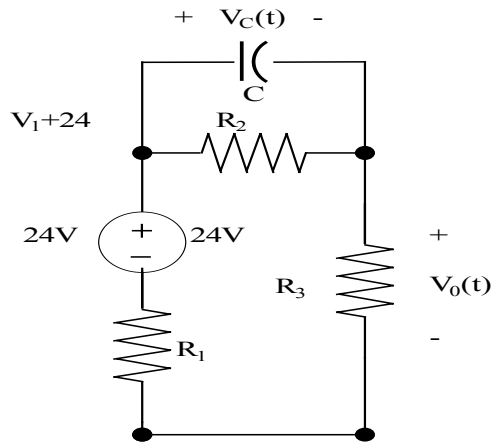

Now, $\frac{dV_0}{dt} + \frac{V_0}{0.6} = 20$ Assume $V_0(t) = K_1 + K_2 e^{-\frac{t}{\tau}}$

substitute, $-K_2 e^{-\frac{t}{\tau}} + \frac{K_1}{0.6} + \frac{K_2 e^{-\frac{t}{\tau}}}{0.6} = 20 \Rightarrow \tau = 0.65$ and $K_1 = 12$

$$V_0(0^+) = \frac{24-6}{2} = 9V = K_1 + K_2 \Rightarrow K_2 = -3$$

$V_0(t) = 12 - 3e^{-\frac{5t}{3}} \text{ V } t > 0 \quad V_0(t) = 6 \text{ V } t < 0$

Problem 6.25

Find $V_C(t)$ for $t > 0$ in the network in Fig. 6.25 using the step-by-step method.

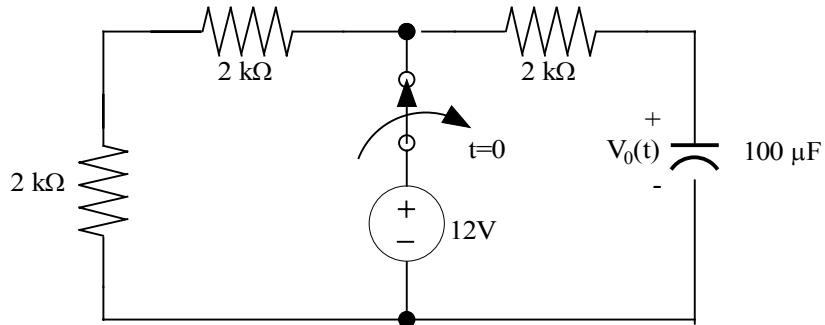

Suggested Solution

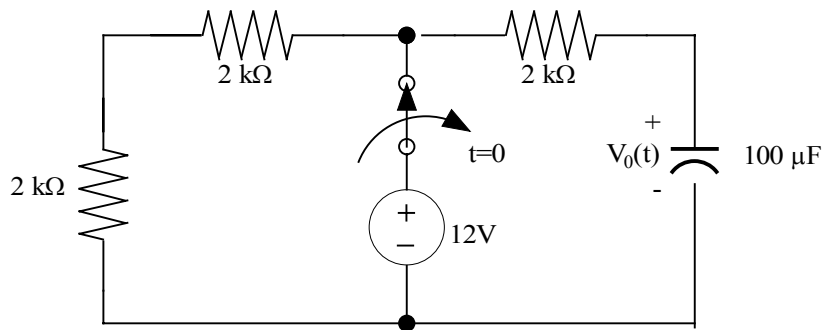

Problem 6.26

Use the step-by-step method to find $i_0(t)$ for $t > 0$ in the circuit in Fig. P.26.

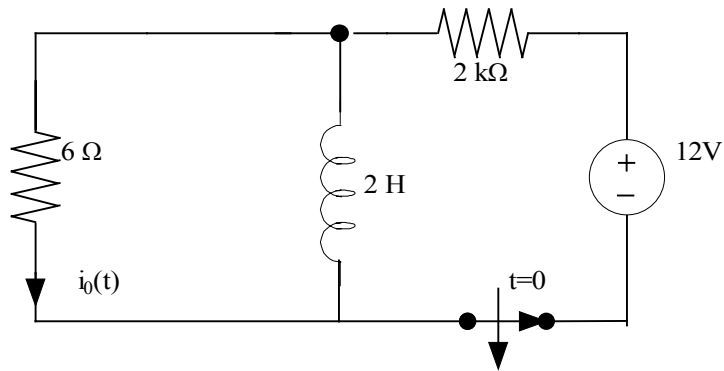

Suggested Solution

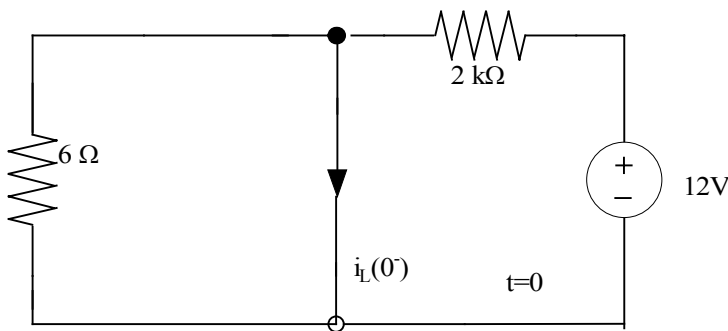

$$i_L(0^-) = \frac{12}{2} = 6A$$

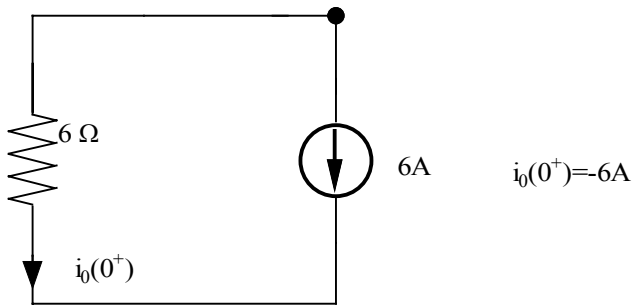

$$i_0(0^+) = -6A$$

$$\tau = \frac{L}{R} = \frac{2}{6} = \frac{1}{3} \text{ sec.} \quad \therefore i_0(t) = -6e^{-3t} A, \quad t > 0$$

Problem 6.27

Find $i_0(t)$ for $t > 0$ in the network in Fig. P6.27 using the step-by-step method.

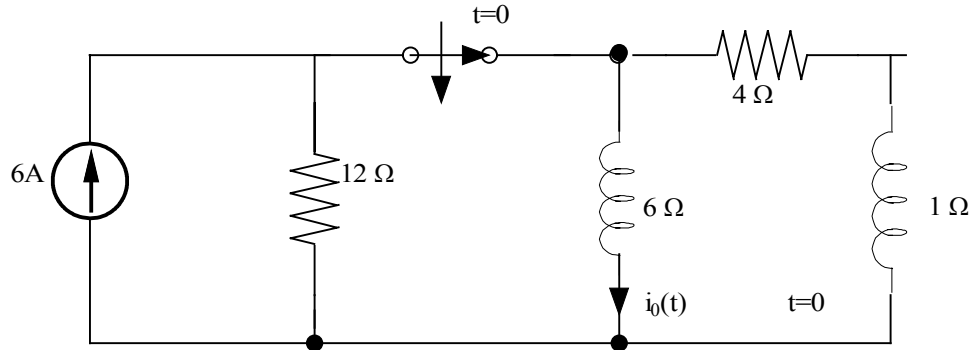

Suggested Solution

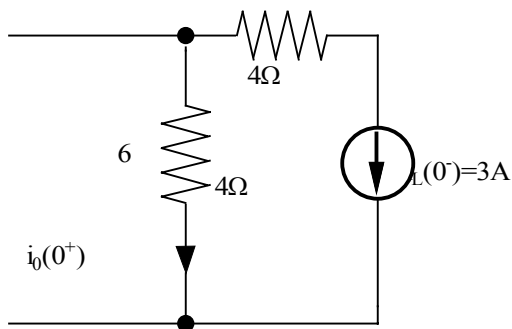
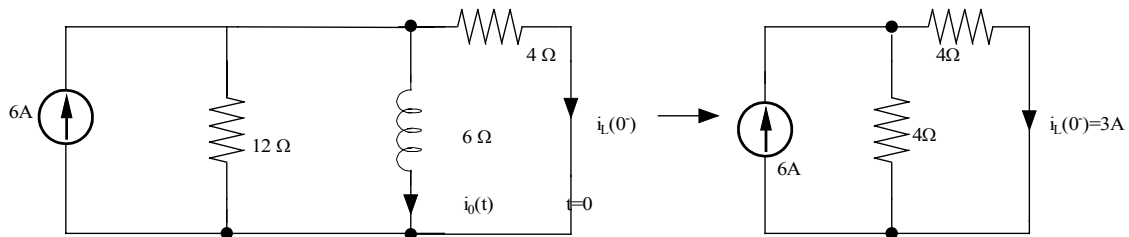

$$i_0(0^+) = -3\text{A}$$

$$i_0(\infty) = 0 \text{ source is out}$$

$$\tau = R = 10 = 10 \text{ sec} \therefore \underline{i_0(t) = -3e^{-10t} \text{ A}, t > 0}$$

Problem 6.28

Use the step-by-step method to find $i_o(t)$ for $t > 0$ in the circuit in Fig. P6.28.

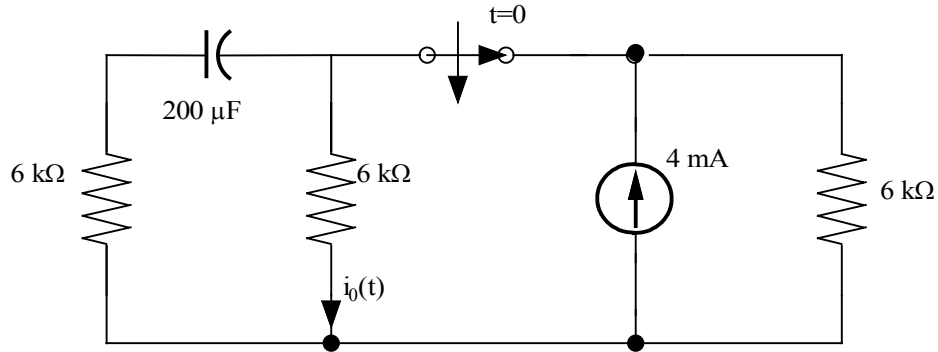

Suggested Solution

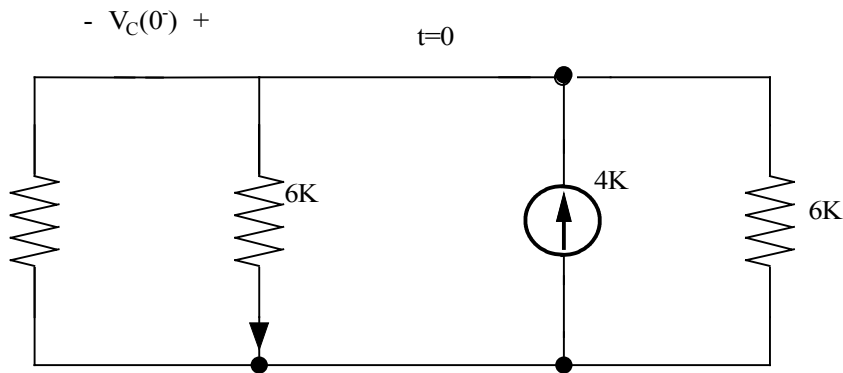

$$V_C(0^-) = \frac{4}{K} = (6K // 6K) = 12V$$

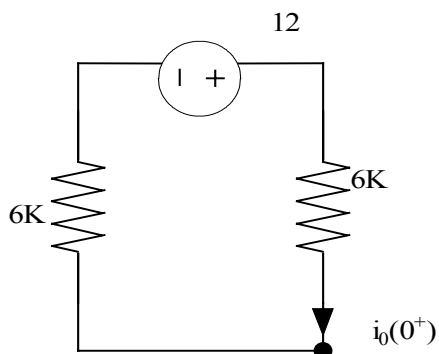

$$i_o(0^+) = \frac{12}{12K} = \frac{1}{K} A$$

$i_o(\infty) = 0$ Source is out of network

$$\tau = RC = 200 \times 10^{-6} \times 12 \times 10^3 = 2.4 \text{ sec}$$

$$i_o(t) = 1e^{-\frac{t}{2.4}} \text{ mA}, t > 0$$

Problem 6.29

Use the step-by-step technique to find $i_0(t)$ for $t > 0$ in the network in Fig. P6.29.

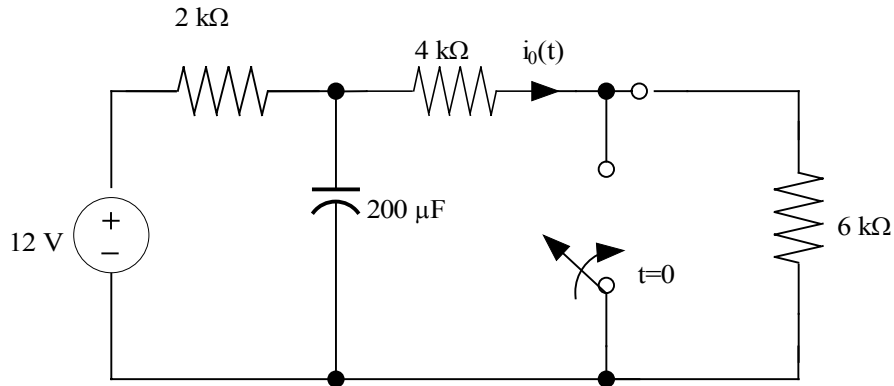

Suggested Solution

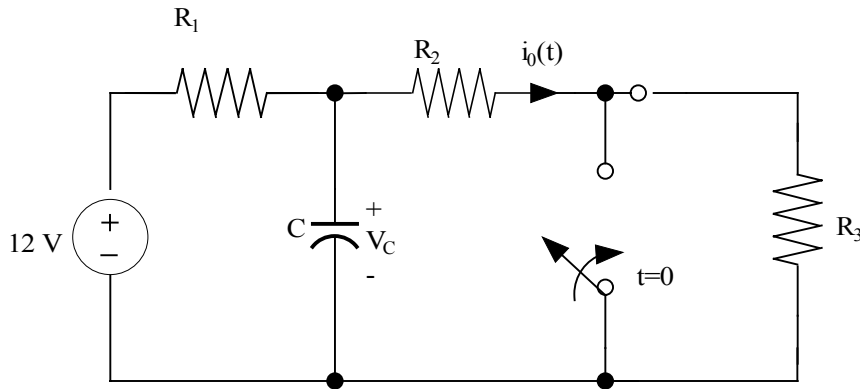

For $t=0^-$

$$V_c(0^-) = V_c(0^+) = 12 \left[\frac{R_2 + R_3}{R_1 + R_2 + R_3} \right] = 10V$$

$R_1 = 2 \text{ k}\Omega$ $R_2 = 4 \text{ k}\Omega$ $R_3 = 6 \text{ k}\Omega$ $C = 0.2 \text{ mF}$ For $t=0^+$

$$i_0(0^+) = \frac{V_c(0^+)}{R_2} = 2.5 \text{ mA}$$

For $t \rightarrow \infty$

$$i_0(t) = 12 = 2 \text{ mA} = K_1$$

$$K_1 + K_2 = 2.5 \text{ mA} \Rightarrow K_2 = 0.5 \text{ mA}$$

$$i_0(t) = K_1 + K_2 e^{-\frac{t}{\tau}}$$

$$\tau = C [R_1 // R_2] = 0.267 \text{ sec.}$$

$$\boxed{i_0(t) = 2 + 0.5 e^{-3.75t} \text{ mA}}$$

Problem 6.30

Use the step-by-step method to find $V_0(t)$ for $t > 0$ in the network in Fig. P6.30.

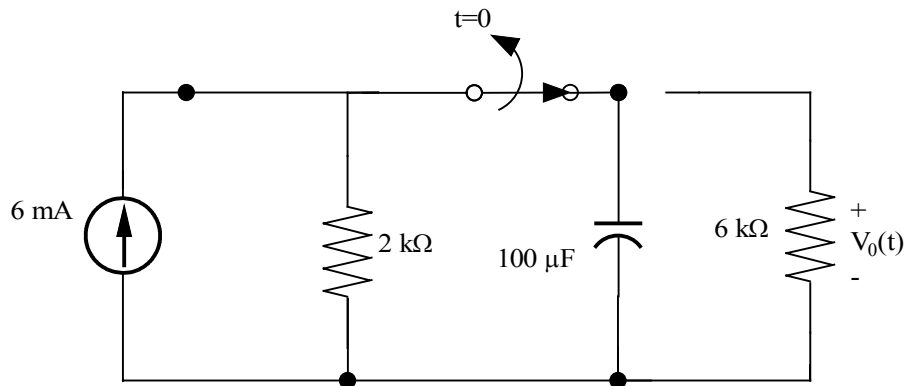

Suggested Solution

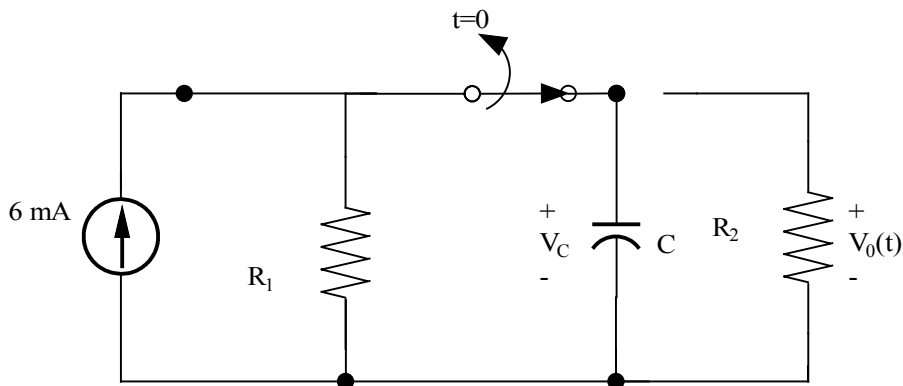

For $t=0^-$

$$V_0(0^-) = V_C(0^+) = 6m(R_1 // R_2) = 9V$$

For $t=0^+$

$$V_C(0^+) = V_0(0^+) = 9V = K_1 + K_2$$

For $t \Rightarrow \infty$

$$V_0(\infty) = 0 = K_1 \Rightarrow K_2 = 9$$

$$\tau = C R_2 = 0.6 \text{ sec}$$

$$R_1 = 2 \text{ k}\Omega \quad R_2 = 6 \text{ k}\Omega \quad C = 0.1 \text{ mF}$$

$$V_0(t) = K_1 + K_2 e^{-\frac{t}{\tau}}$$

$$\boxed{V_0(t) = 9e^{-\frac{5t}{3}} V}$$

Problem 6.31

Use the step-by-step method to find $i_0(t)$ for $t > 0$ in the circuit in Fig. P6.31.

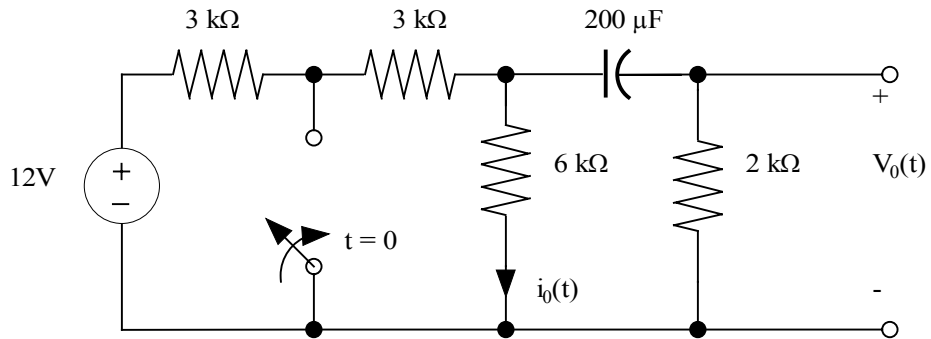

Suggested Solution

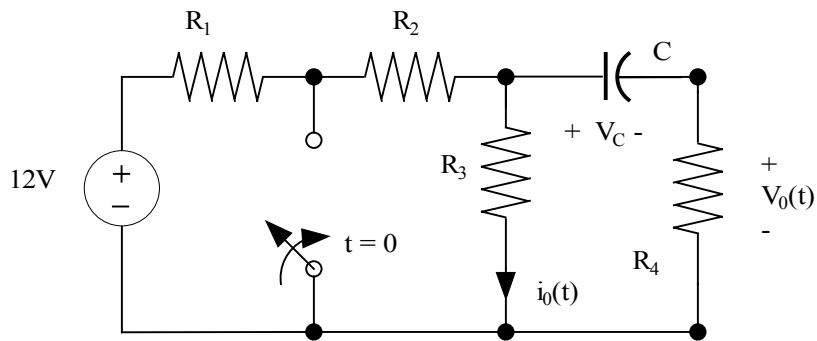

$$R_1=R_2=3K \quad R_3=6k \quad R_4=2K \\ C=0.2 \text{ mF}$$

For $t=0^-$

$$V_C(0^-)=12\left(\frac{R_3}{R_1+R_2+R_3}\right)=6V = V_C(0^+)$$

For $t=0^+$

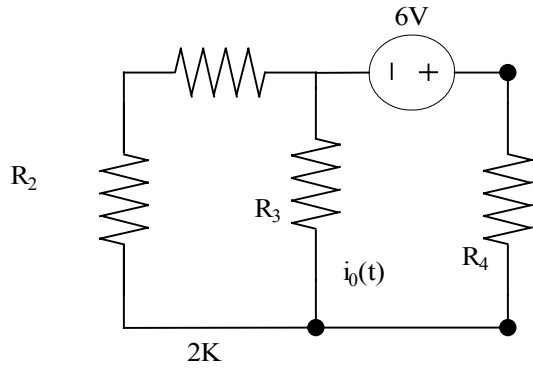

$R_1=R_2=3K \quad R_3=6K \quad R_4=2K \quad C=0.2 \text{ mF}$

For $t \rightarrow \infty$

$$i_s = \frac{6}{4K} = 1.5 \text{ mA}$$

$$i_0(\infty) = 0 = K_1$$

$$i_0 = i_s \left(\frac{3}{3+6} \right) = 0.5 \text{ mA}$$

$$\tau = C R_{eq} \quad R_{eq} = (R_2 // R_3) + R_4$$

$$\tau = 0.8 \text{ s}$$

So, $K_1 + K_2 = 0.5 \text{ mA} = K_2$

$$i_0(t) = 0.5 e^{-\frac{t}{0.8}} \text{ mA}$$

Problem 6.32

Find $V_0(t)$ for $t > 0$ in the network in Fig. P6.32 using the step-by-step technique.

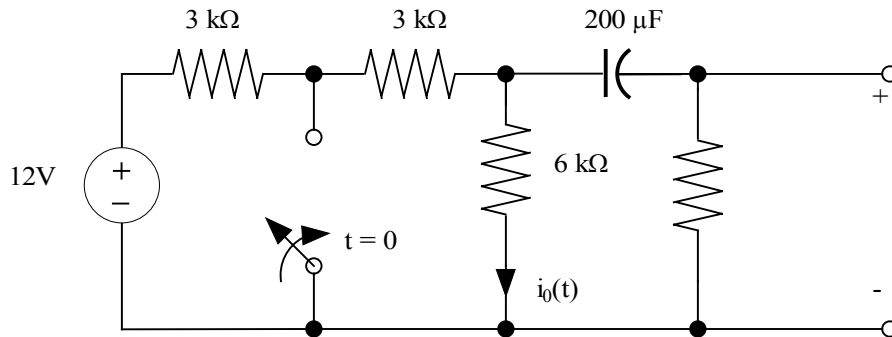

Suggested Solution

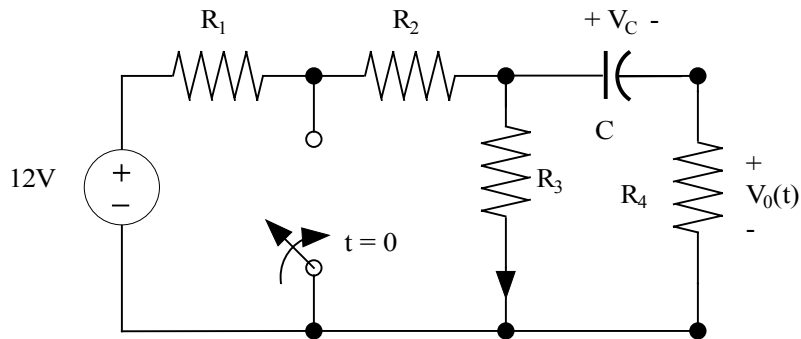

For $t=0^-$

$$V_c = \frac{12 R_3}{R_1 + R_2 + R_3} = 6V = V_c(0^+)$$

For $t=0^+$

$$V_c(0^+) = 6V$$

$$R_1 = R_2 = 3K \quad R_3 = 6K \quad R_4 = 2K \quad C = 0.2mF$$

$$V_0(t) = K_1 + K_2 e^{-\frac{t}{\tau}}$$

$$V_0(0^+) = -V_c \left[\frac{R_4}{R_4 + (R_2 // R_3)} \right] = -3V$$

$$\tau = C [R_4 + (R_2 // R_3)] = 0.8 \text{ s}$$

$$\boxed{V_0(t) = -3e^{-\frac{t}{0.8}} V}$$

Problem 6.33

Find $i_0(t)$ for $t > 0$ in the network in Fig. P6.33 using the step-by-step method.

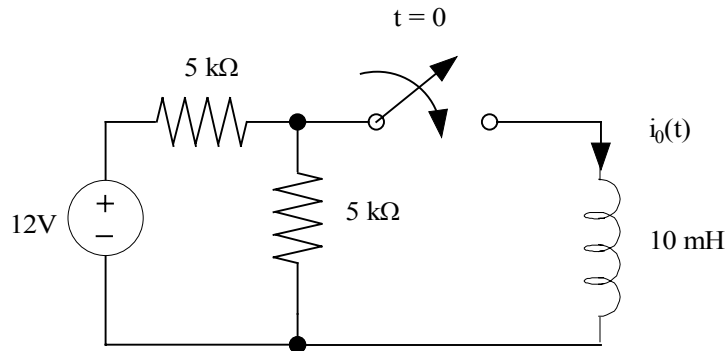

Suggested Solution

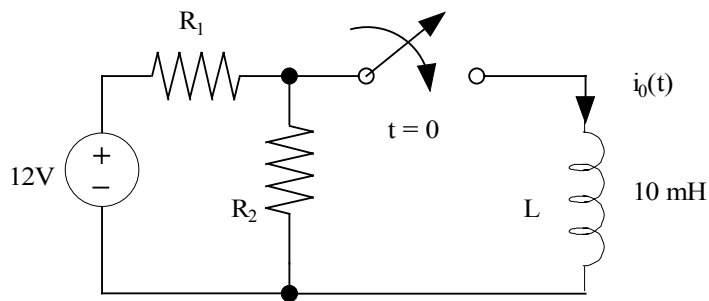

$$R_1 = R_2 = 5 \text{ k}\Omega$$

$$L = 10 \text{ mH}$$

For $t=0^-$

$$i_0(0^-) = i_0(0^+) = 0 \text{ A}$$

$$\text{For } t=0^+: \quad i_0(0^+) = 0 = K_1 + K_2$$

$$\text{For } t=\infty: \quad i_0(\infty) = 12 = 2.4 \text{ mA} = K_1 \Rightarrow K_2 = -2.4 \text{ mA}$$

$$\tau = \frac{L}{R_{eq}} = \frac{L}{R_1 // R_2} = 4 \mu\text{s}$$

$$i_0(t) = 2.4 \left(1 - e^{-2.5 \times 10^5 t} \right) \text{ mA}$$

Problem 6.34

Find $V_0(t)$ for $t > 0$ in the network in Fig. P6.34 using the step-by-step method.

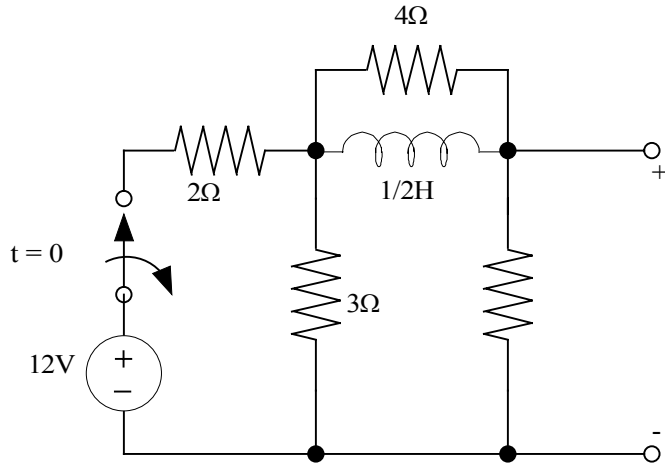

Suggested Solution

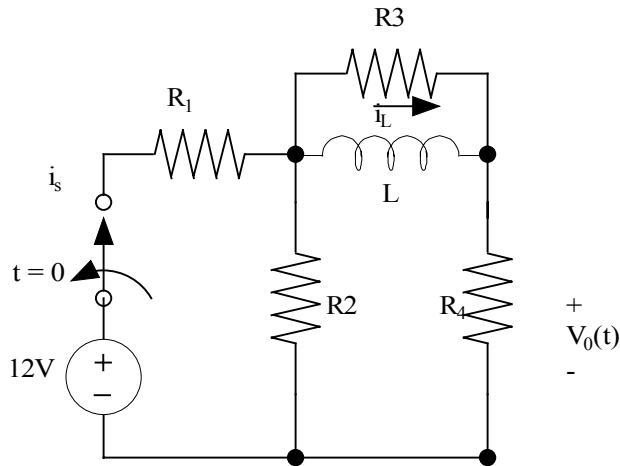

$$\text{For } t=0^-: i_s = \frac{12}{R_1 + (R_2 // R_4)} \quad i_L = \frac{i_s R_2}{R_2 + R_4} = 1\text{A}$$

$$\text{For } t=0^+: V_0 = \frac{-i_L(0^+)R_3}{R_3 + R_2 + R_4} \quad R_4 = \frac{24\text{V}}{13} = K_1 + K_2$$

$$\text{For } t \rightarrow \infty: V_0 = 0 = K_1 \Rightarrow K_2 = \frac{24\text{V}}{13} = 1.85\text{V}$$

$$\tau = \frac{L}{\{R_3 // (R_2 + R_4)\}} = 0.18 \text{ sec}$$

$$R_1 = 2\Omega \quad R_2 = 3\Omega \quad R_3 = 4\Omega$$

$$R_4 = 6\Omega \quad L = \frac{1}{2} \mu$$

$$\boxed{V_0(t) = 1.85e^{-5.54t} \text{V}}$$

Problem 6.35

Use the step-by-step technique to find $V_0(t)$ for $t > 0$ in the network in Fig. P.35.

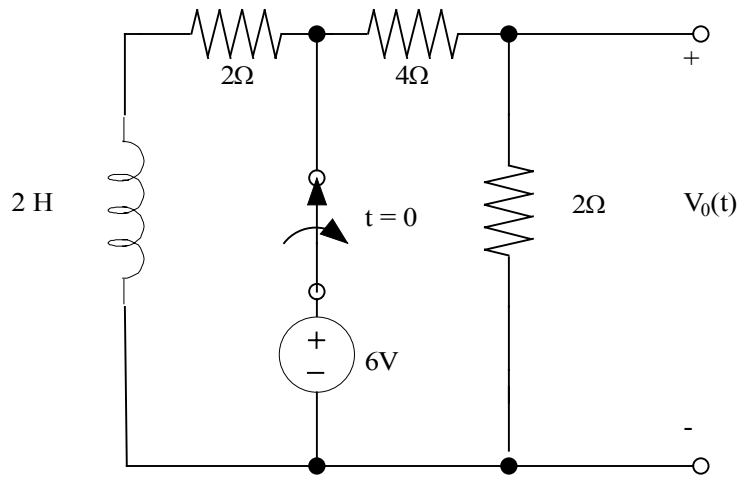

Suggested Solution

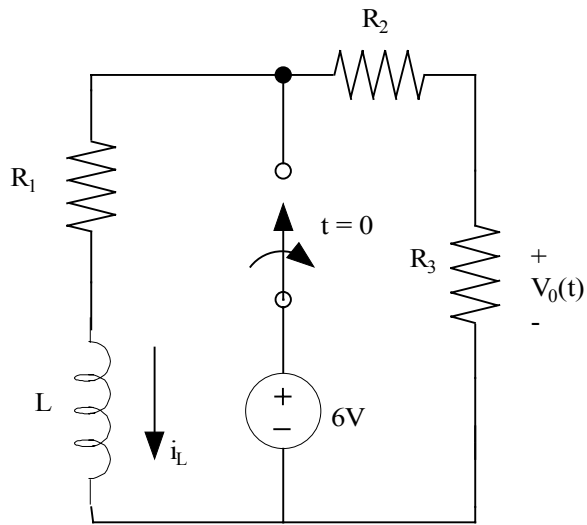

$$\begin{aligned} R_1 &= R_3 = 2 \Omega \\ R_2 &= 4 \Omega \\ L &= 2H \end{aligned}$$

For $t = 0^-$

$$i_L(0^-) = i_L(0^+) = \frac{6}{R_1} = 3A$$

$$V_0(t) = K_1 + K_2 e^{-\frac{t}{\tau}}$$

For $t = 0^+$ $i_L(0^+) = 3A$, $V_0(0^+) = -i_L(0^+)R_3 = -6V = K_1 + K_2$

$$\tau = \frac{L}{R_{eq}} = \frac{L}{R_1 + R_2 + R_3} = \frac{2}{8} = \frac{1}{4} \text{ sec}$$

$$\boxed{V_0(t) = -6e^{-4t} V}$$

Problem 6.36

Use the step-by-step technique to find $i_0(t)$ for $t > 0$ in the networking in Fig. P6.36.

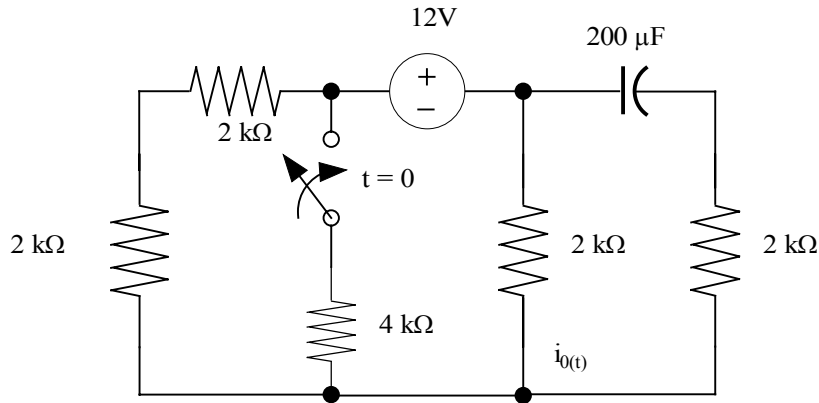

Suggested Solution

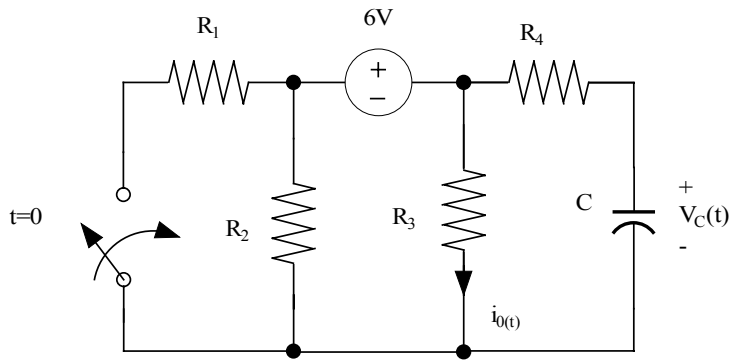

$$R_1=R_2=R_3=R_4=2 \text{ k}\Omega \quad C=0.2 \text{ mF}$$

For $t=0^-$

$$V_C(0^-) = \frac{6R_3}{R_2 + R_3} = 3V$$

$$\text{For } t \rightarrow \infty \quad i_0(\infty) = K_1 = \frac{6}{3k} = 2 \text{ mA}$$

$$\text{so, } K_2 = -0.25 \text{ mA}$$

$$\tau = C \text{Re}q = C \left[2k + \left(\frac{1k}{2k} \right) \right] = \frac{1}{3} \text{ sec}$$

$$i_0(t) = 2 - \frac{e^{-3t}}{4} \text{ mA}$$

For $t=0^+$

$$v_C(0^+) = v_C(0^-) = 3V$$

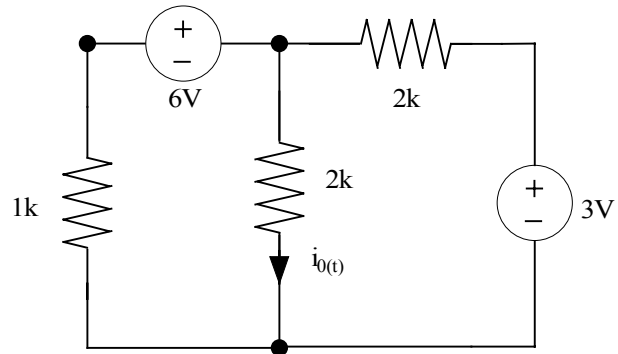

Superposition:

$$i_0 = \frac{6}{2k} \left(\frac{2}{2+2} \right) + \frac{3}{\frac{8}{3}k} \left(\frac{1}{1+2} \right) = 1.75mA$$

$$i_0(0^+) = K_1 + K_2 = 1.75mA$$

Problem 6.37

Find $i_0(t)$ for $t > 0$ in the networking in Fig P6.37 using the step-by-step method.

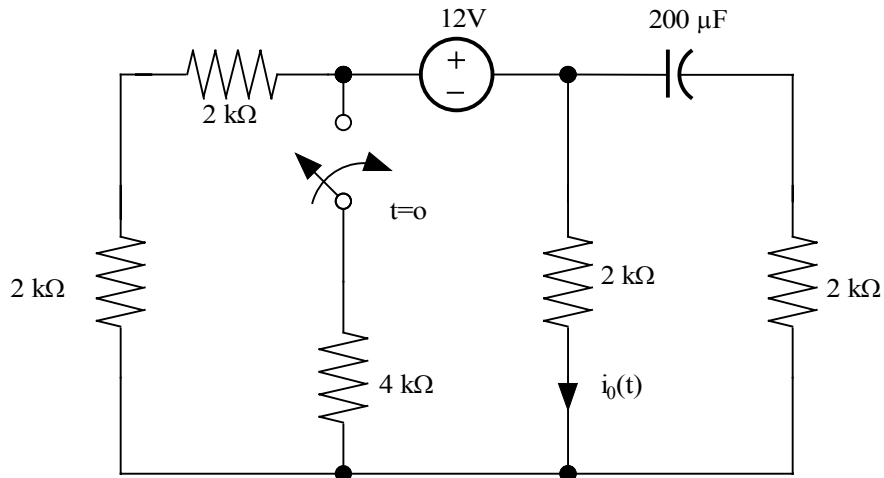

Suggested Solution

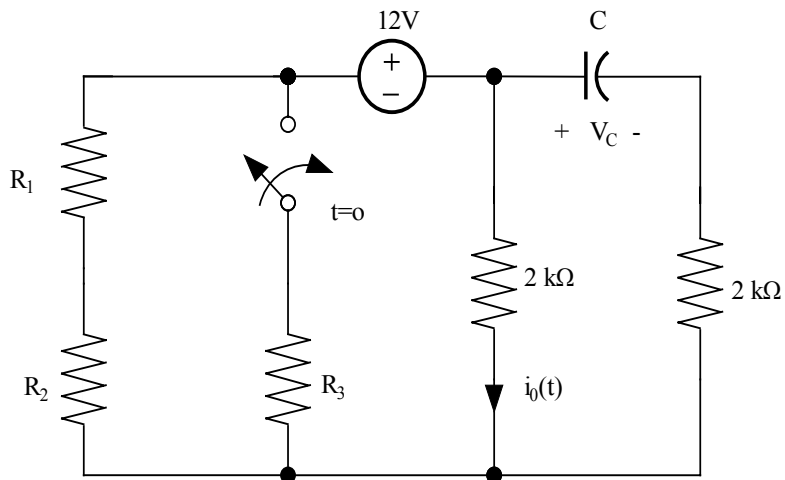

$$R_1 = R_2 = R_4 = R_5 = 2 \text{ k}\Omega \quad \text{For } t=0^-$$

$$R_3 = 4 \text{ k}\Omega, \quad C = 0.2 \text{ mF} \quad V_C(0^-) = \frac{12R_4}{R_1 + R_2 + R_4} = 4 \text{ V}$$

$$i_0(t) = K_1 + K_2 e^{-\frac{t}{\tau}}$$

For $t > 0$

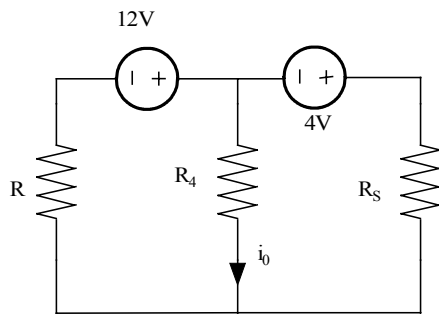

$$R = R_3 // (R_1 + R_2) = 2 \text{ K}\Omega$$

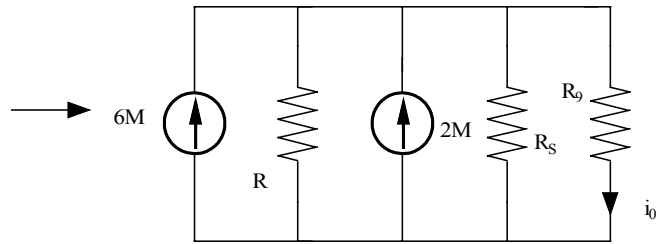

$$i_0(0^+) = K_1 + K_2 = \frac{8M [R // R_5]}{[R // R_5] + R_4} = \frac{8}{3} \text{ mA}$$

For $t \Rightarrow \infty$: $i_0(\infty) = K_1 = \frac{12}{R + R_4} = 3 \text{ mA} \Rightarrow K_2 = \frac{-1}{3} \text{ mA}$

$$\tau = C R_{eq} = C \{R_5 + (R // R_4)\} = 0.6 \text{ sec}$$

$$i_0(t) = 3 - \frac{e^{-t/0.6}}{3} \text{ mA}$$

Problem 6.38

Use the step-by-step technique to find $i_0(t)$ for $t > 0$ in the network in Fig. P6.38.

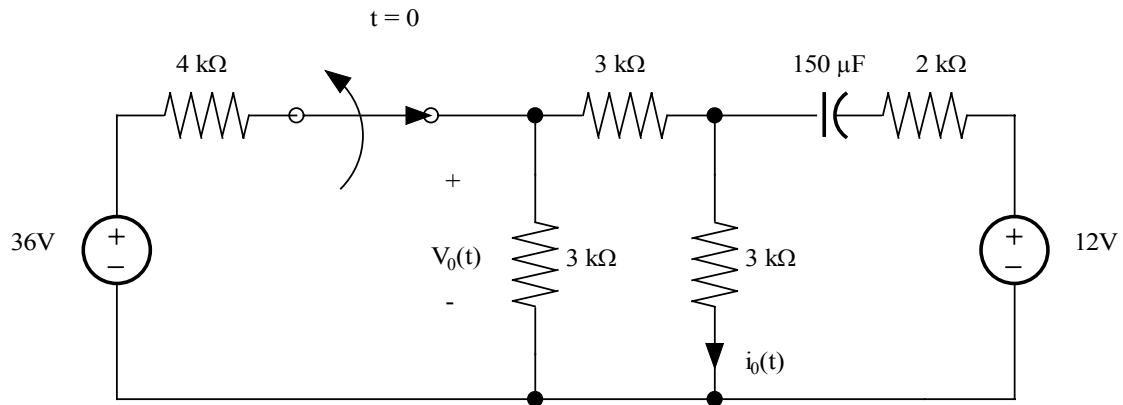

Suggested Solution

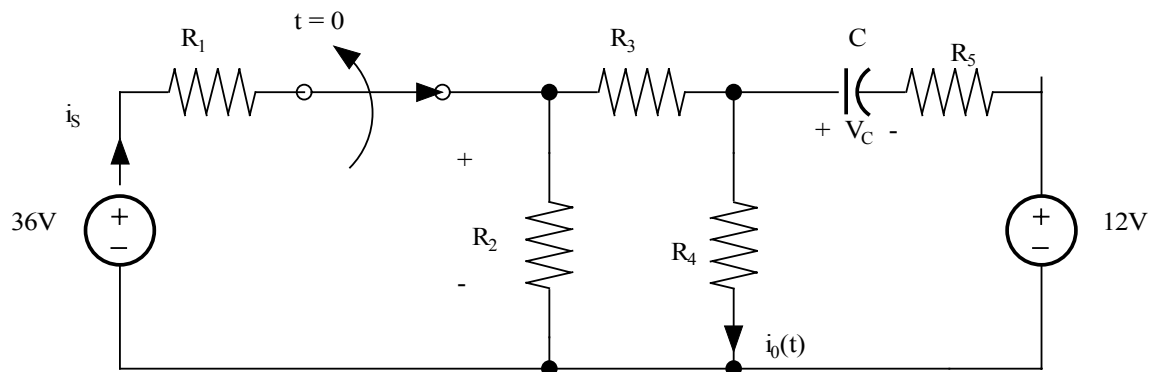

$$R_1 = 4\text{ k}\Omega \quad R_5 = 2\text{ k}\Omega \quad C = 0.15\text{ mF}$$

$$R_2 = R_3 = R_4 = 3\text{ k}\Omega$$

$$i_0(t) = K_1 + K_2 e^{-\frac{t}{\tau}}$$

For $t=0^-$

$$i_s = \frac{36}{R_1 + R_2 // (R_3 + R_4)} = 6A \quad i_0 = \frac{i_s R_2}{R_2 + R_3 + R_4} = 2 \text{ mA} \quad V_C = i_0 R_4 - 12 = -6V$$

For $t=0^+$

$$V_C(0^+) = V_C(0^-) = -6V, \quad R_4 i_0 = \frac{[12 + V_C(0^+)] [R_4 // (R_2 + R_3)]}{R_4 // (R_2 + R_3) + R_5} = 3V$$

so, $i_0(0^+) = K_1 + K_2 = 1 \text{ mA}$

For $t=\infty$ $i_0(\infty) = 0 = K_1 \Rightarrow K_2 = 1 \text{ mA}$

$$\tau = C R_{eq} = C \{ R_5 + [R_4 // (R_2 + R_3)] \} = 0.6 \text{ sec}$$

$$i_0(t) = 1 e^{\frac{-t}{0.6}} \text{ mA}$$

Problem 6.39

Find $V_0(t)$ for $t > 0$ in the circuit in Fig. P6.38 using the step-by-step method.

Suggested Solution

Problem 6.40

Find $i_0(t)$ for $t > 0$ in the network in Fig. P6.40 using the step-by-step method.

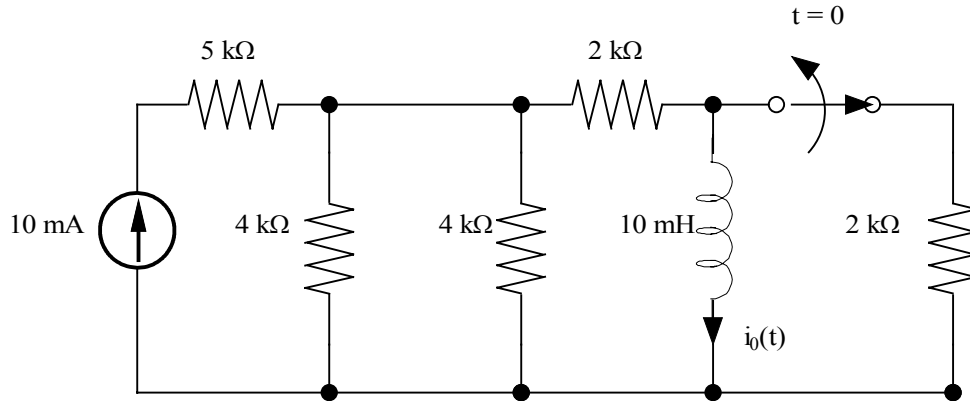

Suggested Solution

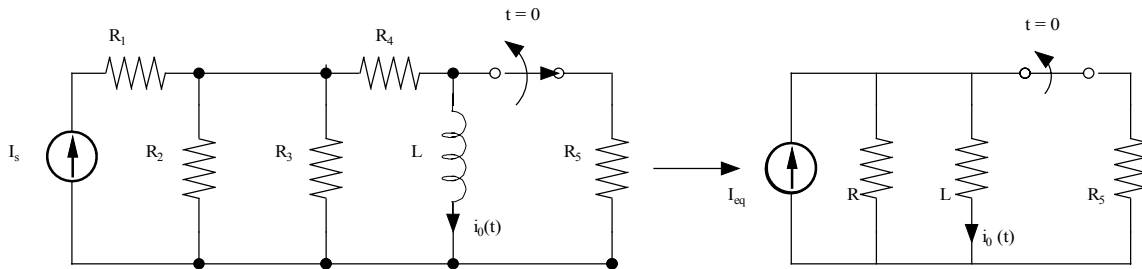

$$R_1 = 5 \text{ k}\Omega \quad R_2 = R_3 = 4 \text{ k}\Omega \quad I_s = 10 \text{ mA} \quad R = R_4 + (R_1 // R_2 // R_3) = 3.43 \text{ k}\Omega$$

$$L = 10 \text{ mH} \quad R_4 = R_5 = 2 \text{ k}\Omega \quad I_{eq} = 5 \text{ mA}$$

$$\text{For } t = 0^- : i_0(0^-) = i_0(0^+) = I_{eq} = 5 \text{ mA} = k_1 + k_2$$

$$\text{For } t = 0^+ : i_0(0^+) = I_{eq} = 5 \text{ mA} = k_1 + k_2$$

$$\text{For } t = \infty : i_0(\infty) = 5 \text{ mA} = k_1 \Rightarrow k_2$$

$$\boxed{i_0(t) = 5 \text{ mA}}$$

Problem 6.41

Find $V_0(t)$ for $t > 0$ in the network in Fig. P6.41 using the step-by-step method.

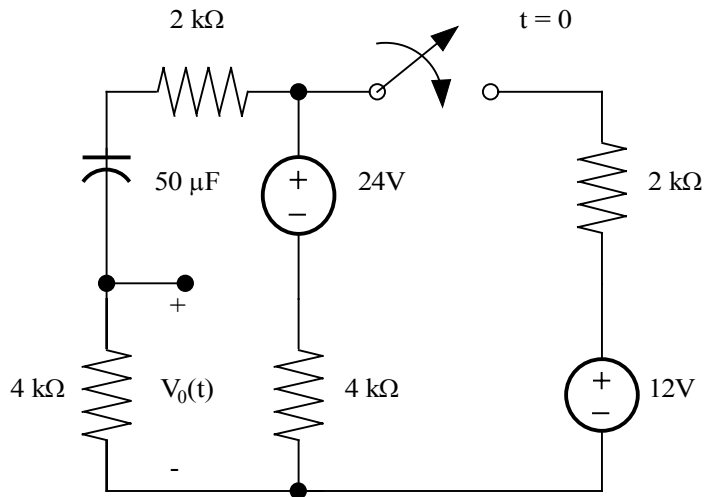

Suggested Solution

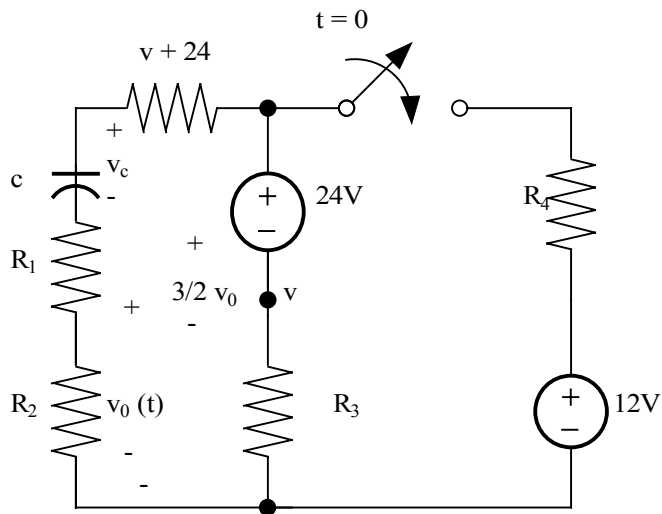

$$R_2 = R_3 = 4 \text{ k}\Omega, \quad R_1 = R_4 = 2 \text{ k}\Omega, \quad c = 50 \text{ }\mu\text{F}$$

$$\text{For } t \rightarrow \infty : v_0 \rightarrow 0 = k_1 \rightarrow k_2 = 4.37 \text{ V}$$

$$\tau = c [R_1 + R_2 + (R_3 // R_4)] = 0.37 \text{ sec}$$

$$\text{For } t = 0^- : v_0 = 0 \text{ V}, \quad v_c = 24 \text{ V}$$

$$\text{For } t = 0^+ : \frac{v}{R_1 + R_2} + \frac{v}{R_3} + \frac{v + 24 - 12}{R_4} = 0$$

$$v = 6.55 \text{ V}, \quad v_0 = \frac{2}{3}v = 4.37 \text{ V} = k_1 + k_2$$

$$v_0(t) = 4.37 e^{-t/0.37} \text{ V}$$

Problem 6.42

Find $V_0(t)$ for $t > 0$ in the network in Fig. P6.42 using the step-by-step method.

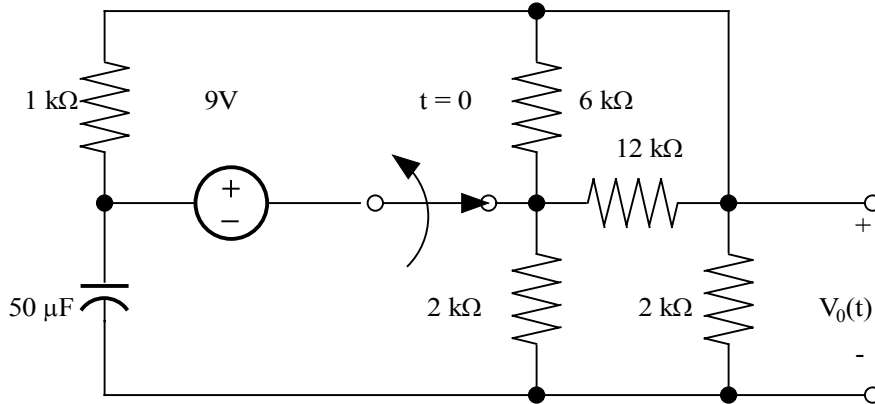

Suggested Solution

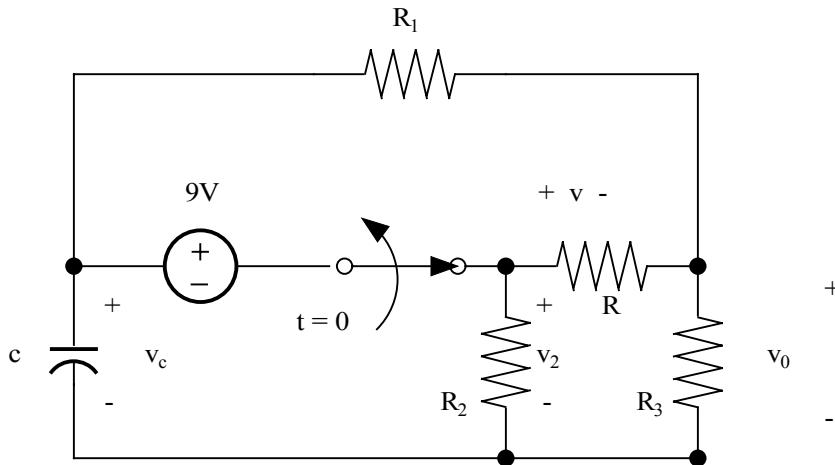

$$R_1 = 1 \text{ k}\Omega, \quad R_2 = R_3 = 2 \text{ k}\Omega, \quad c = 50 \text{ }\mu\text{F}$$

$$R = 6 \text{ k}\Omega // 12 \text{ k}\Omega = 4 \text{ k}\Omega$$

For $t \rightarrow \infty$: $v_0(\infty) \rightarrow 0 = k_1 \rightarrow k_2 = -3.6V$

$$\tau = c \left[R_1 + (R_3 // (R + R_2)) \right] = \frac{1}{8} \text{ sec}$$

For $t = 0^-$: $v_c = 9 - v_2, v_2 = v \left(\frac{R_2}{R_2 + R_3} \right) = \frac{v}{2},$

$$v = 9 \left[\frac{R // (R_2 + R_3)}{R // (R_2 + R_3) + R_1} \right] = 6V$$

So, $v_2 = 3V, v_c(0^-) = 6V$

$$v_0 = -3.6e^{-8t}V$$

Problem 6.43

Find $i_0(t)$ for $t > 0$ in the circuit in Fig. P6.43 using the step-by-step method.

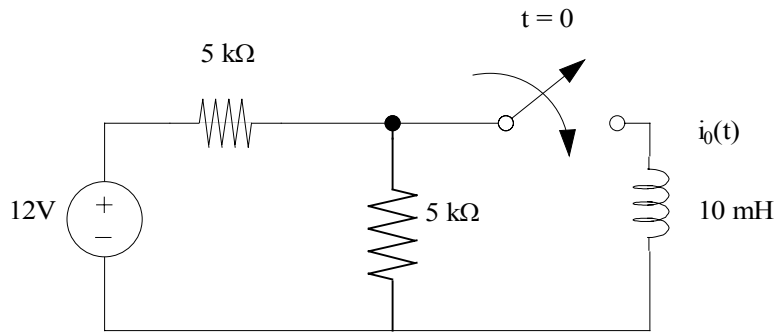

Suggested Solution

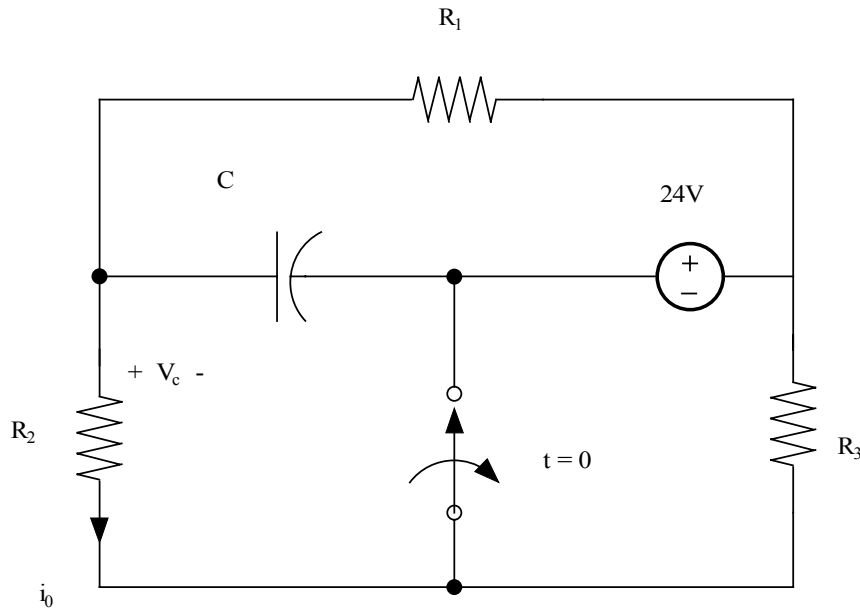

$$\begin{aligned} R_1 &= 4 \text{ k}\Omega \\ R_2 &= 2 \text{ k}\Omega \\ R_3 &= 10 \text{ k}\Omega \\ C &= 200 \text{ }\mu\text{F} \end{aligned}$$

$$\underline{\text{For } t \rightarrow \infty} : i_0 \rightarrow 0 = k_1, \quad \text{So, } k_2 = -\frac{4}{3} \text{ mA}$$

$$\tau = c[R_1 // (R_2 + R_3)] = 0.6 \text{ sec}$$

$$\underline{\text{For } t = 0^-} : i_0 = \frac{24}{R_1 + R_2} = 4 \text{ mA}, \quad v_c = i_0 R_2 = 8 \text{ V}$$

$$\underline{\text{For } t = 0^+} : i_0 = \frac{v_c(0^+) - 24}{R_2 + R_3} = \frac{8 - 24}{12 \text{ k}} = -\frac{4}{3} \text{ mA}$$

$$i_0(0^+) = -\frac{4}{3} \text{ mA} = k_1 + k_2$$

$$\boxed{i_0(t) = -1.33e^{-t/0.6} \text{ mA}}$$

Problem 6.44

Find $V_o(t)$ for $t > 0$ in the network in Fig. P6.44 using the step-by-step method.

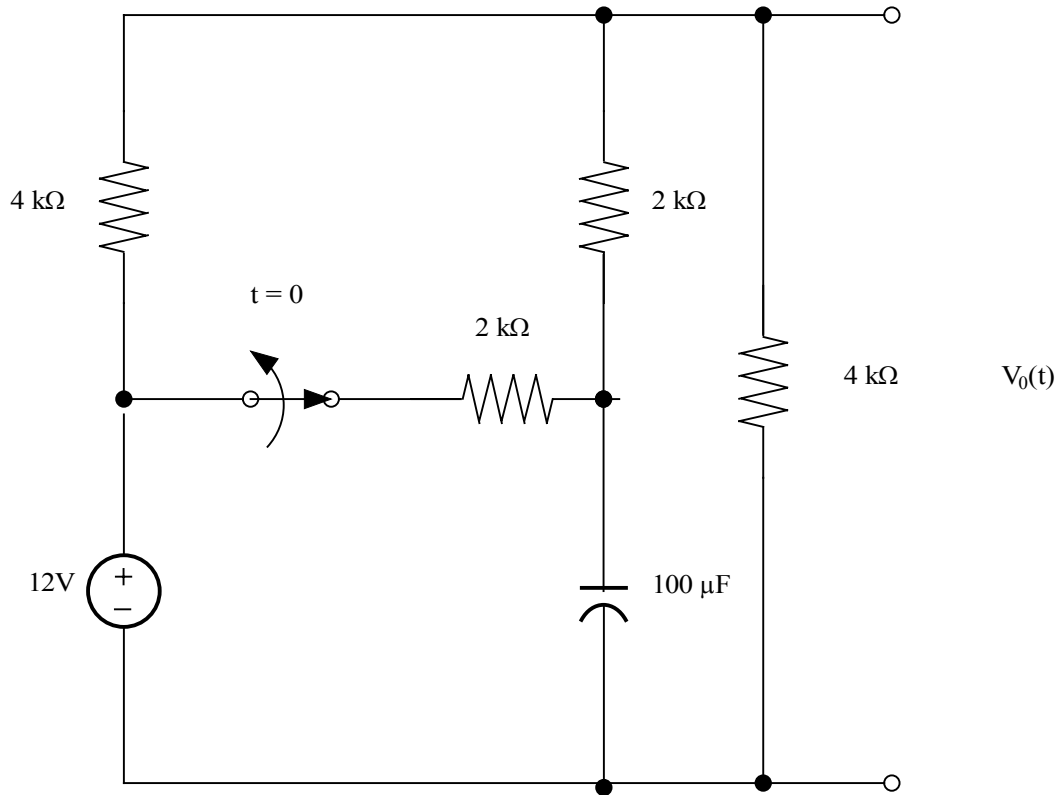

Suggested Solution

for $t=0^-$

$$v_o = 12 \left[\frac{R_4}{R_4 + (R_1 \parallel (R_2 + R_3))} \right]$$

$$v_2 = (12 - v_o) \left[\frac{R_2}{R_2 + R_3} \right] = 2V$$

$$v_c = (12 - v_2) = 10V$$

for $t=0^+$

$$\frac{(12 - v_o)}{R_1} + \frac{v_c(0^+) - v_o}{R_3} = \frac{v_o}{R_4}$$

$$v_c(0^+) = v_c(0^-) = 10V$$

$$12 - v_o - 2v_o + 20 = v_o \Rightarrow v_o(0^+) = 8V = k_1 + k_2$$

for $t \Rightarrow \infty$:

$$v_o = 12 \left(\frac{R_4}{R_4 + R_1} \right) = 6V = k_1 \Rightarrow k_2 = 2V$$

$$v_o(t) = 6 + 2e^{-2.5t} V$$

Problem 6.45

Use the step-by-step method to find $i_o(t)$ for $t > 0$ in the network in Fig. P6. 45.

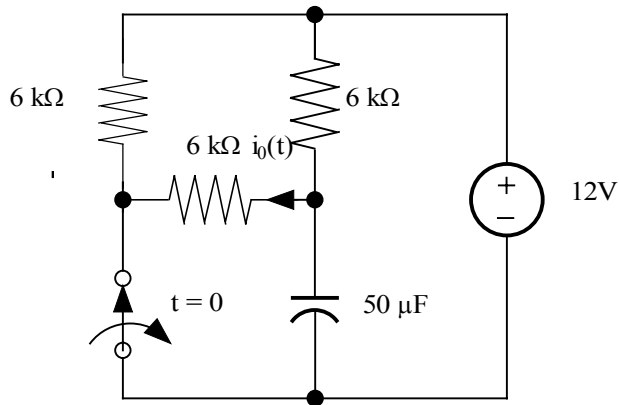

Suggested Solution

for $t=0^-$

$$v_c = 12 \left[\frac{R_2}{R_2 + R_3} \right] = 6V$$

for $t=0^+$

by superposition

$$i_o = \frac{-12}{R_1 + R_2} + \frac{v_c(0^+)}{R_1 + R_2} = -1 + 0.5 = -0.5mA$$

$$i_o(0^+) = -0.5mA = k_1 + k_2$$

for $t \Rightarrow \infty$:

$$i_o(\infty) = 0 = k_1 \Rightarrow k_2 = -0.5mA$$

$$i_o(t) = -0.5e^{-5t}mA$$

Problem 6.46

Find $V_o(t)$ for $t > 0$ in the circuit in Fig. P6.46 using the step-by-step method.

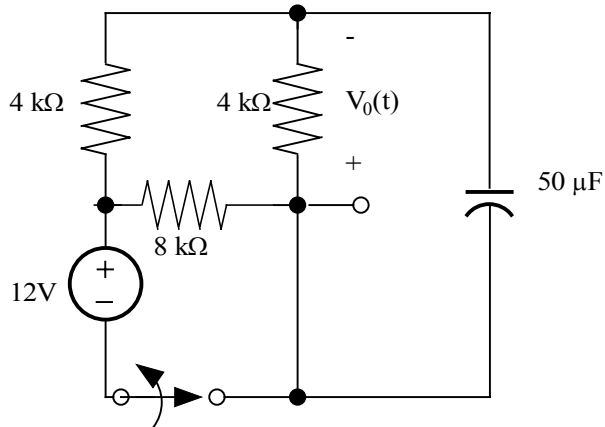

Suggested Solution

for $t=0^-$

$$v_o = 12 \left[\frac{R_3}{R_3 + R_1} \right] = 6V$$

$$v_c = -v_o = -6V = v_c(0^+)$$

for $t=0^+$

$$v_o = -v_c = -6V$$

$$v_o(0^+) = 6 = k_1 + k_2$$

for $t \Rightarrow \infty$:

$$v_o(\infty) = 0 = k_1 \Rightarrow k_2 = 6$$

$$v_o(t) = 6e^{\frac{-t}{0.15}}$$

Problem 6.47

Use the step-by-step technique to find $V_o(t)$ for $t > 0$ in the circuit in Fig. P6.47.

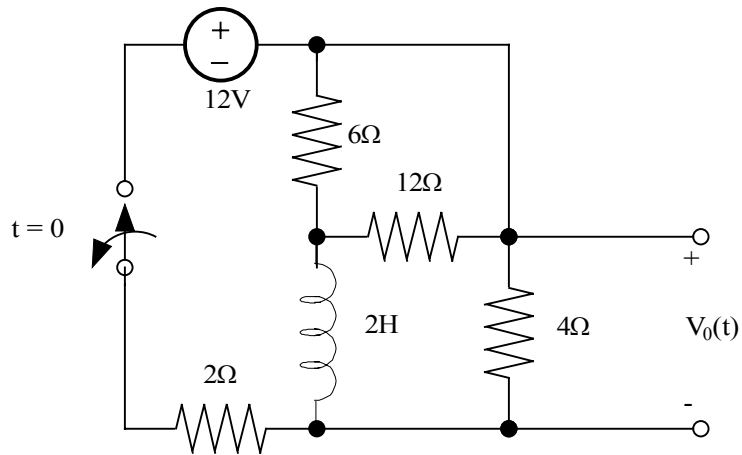

Suggested Solution

for $t=0^-$

$$i_s = \frac{12}{R_1 + (R_2 \parallel R)} = 3A$$

$$i_L = \frac{i_s R_2}{R_2 + R} = 1.5A = i_L(0^+)$$

$$\tau = \frac{L}{R_2 + R} = \frac{1}{4}s$$

for $t=0^+$

$$v_o = -i_L R_2 = -6 = k_1 + k_2$$

for $t \Rightarrow \infty$:

$$v_o = 0 = k_1 \Rightarrow k_2 = 6V$$

$$v_o(t) = -6e^{-4t}V$$

Problem 6.48

Find $V_0(t)$ for $t > 0$ in the circuit in Fig. P6.48 using the step-by-step method.

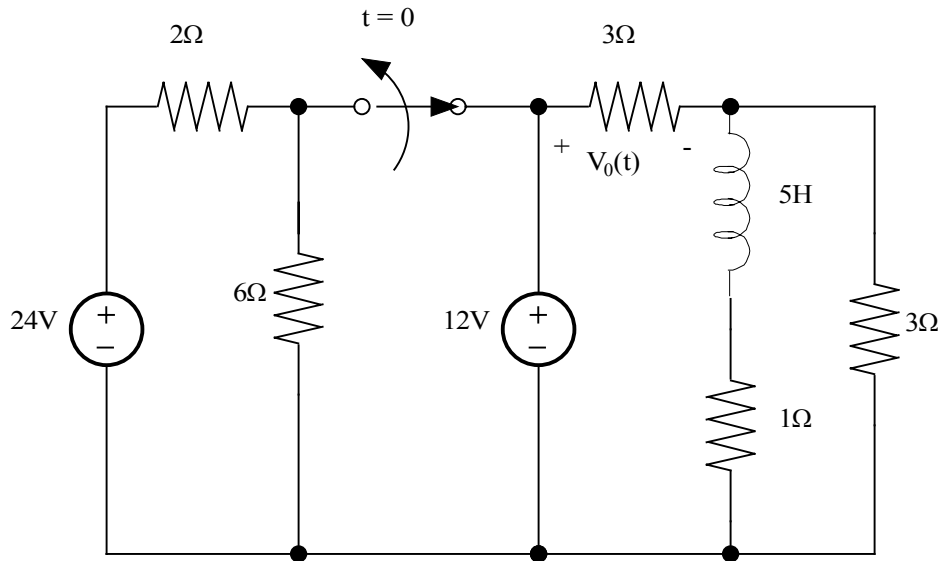

Suggested Solution

for $t=0^-$

$$i_o = \frac{12}{R_3 + (R_4 \parallel R_5)} = 3.2A$$

$$i_L = i_o \left(\frac{R_5}{R_4 + R_5} \right) = 2.4A$$

use superposition,

for $t=0^+$

$$v_o = 12 \left(\frac{R_3}{R_3 + R_5} \right) + i_L(0^+) R_3 \left(\frac{R_5}{R_4 + R_5} \right) = 9.6$$

$$v_o(0^+) = 9.6 = k_1 + k_2$$

for $t \Rightarrow \infty$:

$$v_o = 12 \left(\frac{R_3}{R_3 + (R_4 \parallel R_5)} \right) = 9.6 = k_1$$

$$k_2 = 0$$

$$v_o = 9.6V$$

Problem 6.49

Use the step-by-step method to find $V_o(t)$ for $t > 0$ in the network in Fig. P6.49.

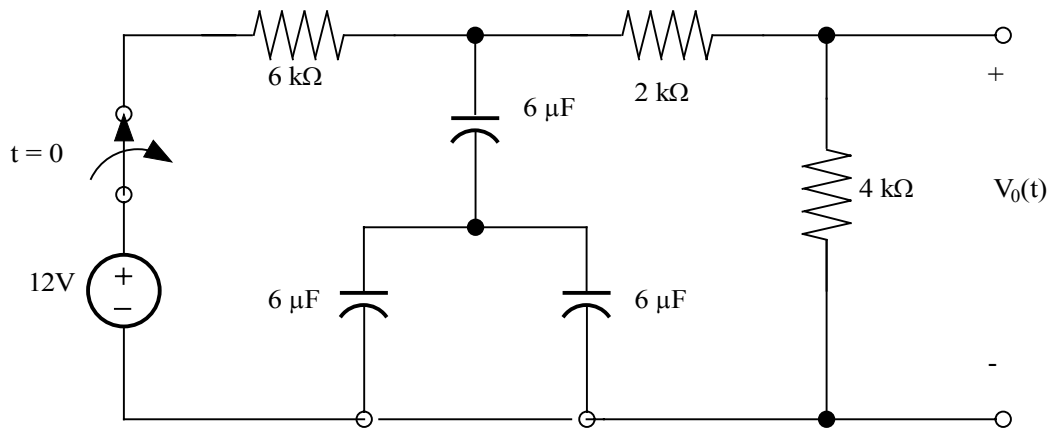

Suggested Solution

$$v_o(t) = k_1 + k_2 e^{\frac{-t}{\tau}} \quad v_o(0^+) = 6V$$

$$\tau = R_{AC} = 6k \left(\frac{4}{k} \Omega \right) = 0.0245$$

$$v_o(t) = 4e^{\frac{-t}{0.0245}} V$$

$$t > 0$$

Problem 6.50

Find $V_o(t)$ for $t > 0$ in the network in Fig. P6.50 using the step-by-step method.

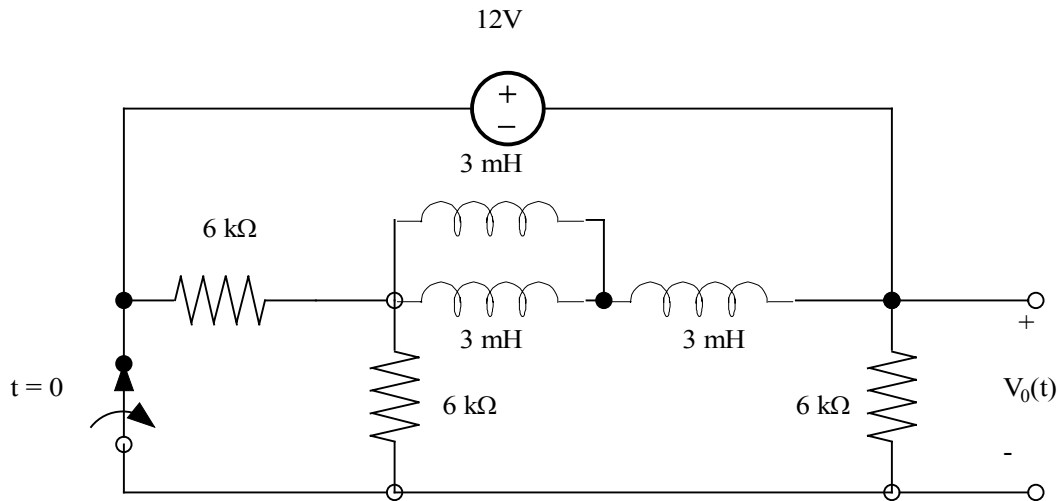

Suggested Solution

$$v_o(t) = k_1 + k_2 e^{-\frac{t}{\tau}} \quad i_L(0^-) = \frac{12}{6k} + \frac{12}{6k} = \frac{4}{k} A$$

$$v_c(0^+) = \frac{-2}{k} \left(\frac{6k}{6k+12} \right) 6k = -4V$$

$$\tau = \frac{L}{R_{th}} = \frac{4.5 \cdot 10^{-6}}{4k}$$

$$v_o(t) = -4e^{-\frac{t}{\tau}}$$

Problem 6.51

Use the step-by-step method to find $i_0(t)$ for $t > 0$ in the network in Fig. P6.51

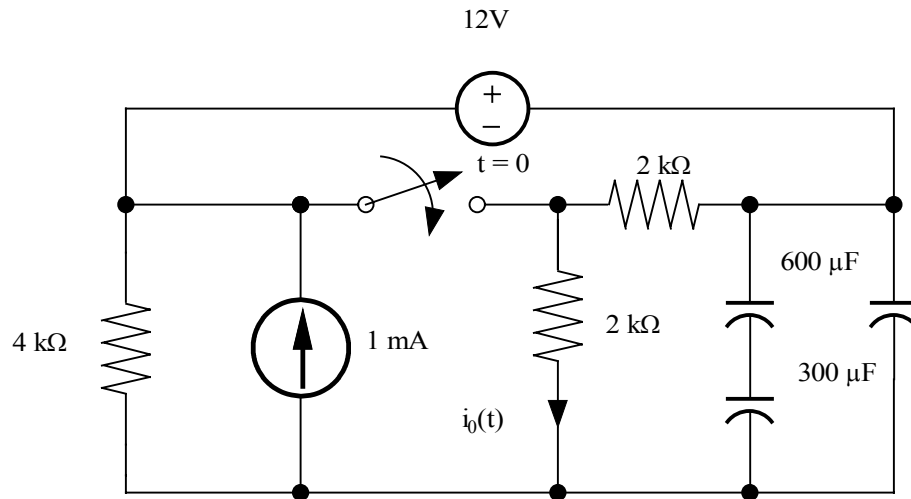

Suggested Solution

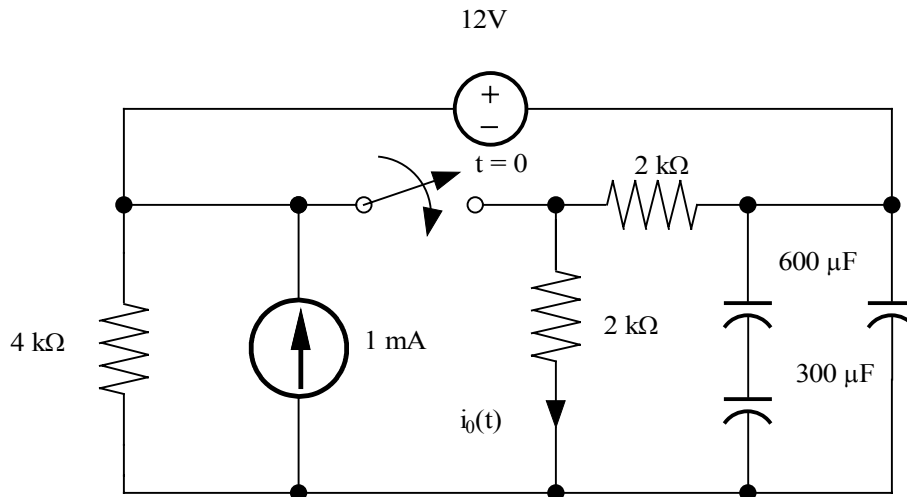

$$R_1 = 4k\Omega, R_2 = R_3 = 2k\Omega$$

$$c = 200\mu + \frac{1}{\frac{1}{600\mu} + \frac{1}{300\mu}} = 400\mu F$$

For

$t = 0^+$, Use Superposition

$$i_{012v} = \frac{-12}{R_2} = -6mA$$

$$i_{01mA} = 1m(0) = 0$$

$$i_{0v_c(0^+)} = \frac{8}{R_2} = 4mA$$

$$i_0(0^+) = \sum i_0 = -2mA = K_1 + K_2$$

$t = 0^-$, Use Superposition

$$v_c = 12\left(\frac{R_2 + R_3}{R_1 + R_2 + R_3}\right) + 1m\left(\frac{R_1}{R_1 + R_2 + R_3}\right)$$

$$v_c = 8v = v_c(0^+)$$

$$\tau = c[R_1 \parallel R_2] = \frac{8}{15}$$

for

$t \rightarrow \infty$

$$i_0 = 1m\left(\frac{R_1}{R_1 + R_2}\right) = \frac{2}{3}mA$$

$$i_0(\infty) = \frac{2}{3}mA = K_1$$

$$K_2 = -\frac{8}{3}mA$$

$$i_0(t) = \frac{2}{3} - \frac{8}{3}e^{-15t/8}mA$$

Problem 6.52

Use the step-by-step method to find $i_0(t)$ for $t > 0$ in the network in Fig. P6.52

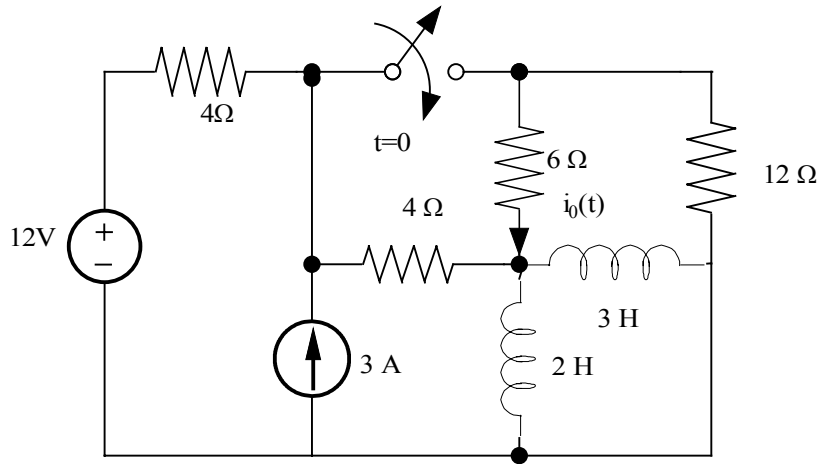

Suggested Solution

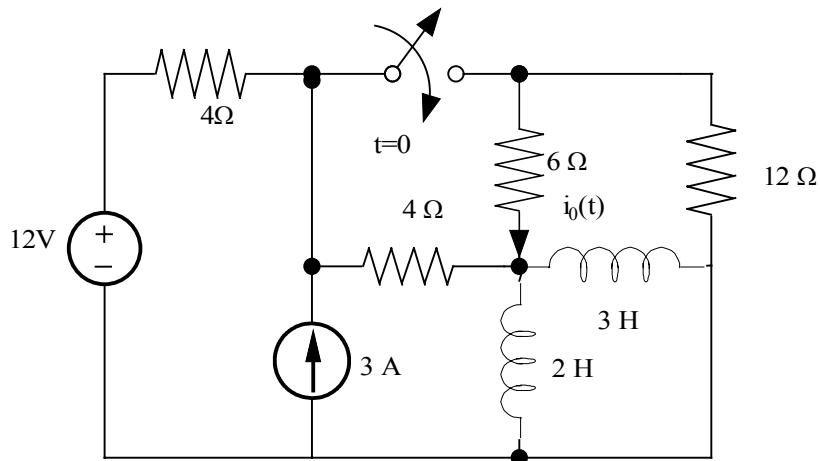

$$R_1 = 4 = R_2 = 4\Omega$$

$$R_3 = 6\Omega$$

$$R_4 = 12\Omega$$

$$L = \frac{1}{\frac{1}{2} + \frac{1}{3}} = 1.2H$$

$$\tau = \frac{L}{R_2 \parallel R_3 + R_1 \parallel R_3} = \frac{2}{9}$$

$$i_0 = \frac{4}{3} - \frac{2}{15} e^{-9t/2} A$$

For

$$t = 0^-$$

$$i_L = \frac{24}{R_1 + R_2} = 3A = i_L(0^+)$$

For

$$t = 0^+$$

$$i_0 = i_2(0^+) \left[\frac{R_2}{R_2 + R_3} \right] = 1.2A = K_1 + K_2$$

For

$$t \rightarrow \infty$$

$$i_0 = \frac{24}{R_1 + (R_2 \parallel R_3 \parallel R_4)} \left[\frac{R_2 \parallel R_4}{(R_2 \parallel R_4) + R_3} \right]$$

$$i_0 = \frac{4}{3} = K_1 \Rightarrow K_2 = \frac{-2}{15}$$

Problem 6.53

Find $i_0(t)$ for $t > 0$ in the circuit in Fig. P6.53 using the step-by-step method.

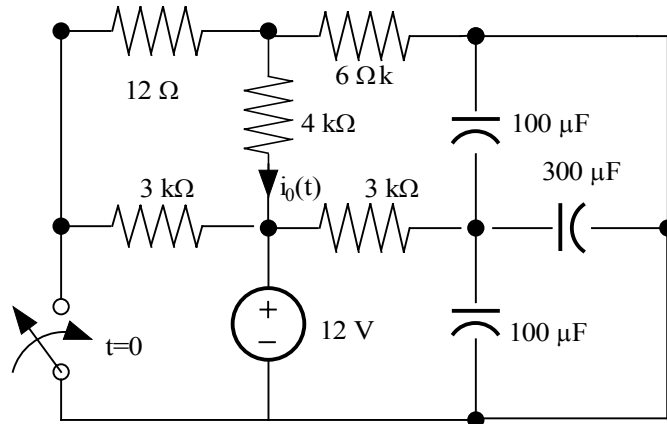

Suggested Solution

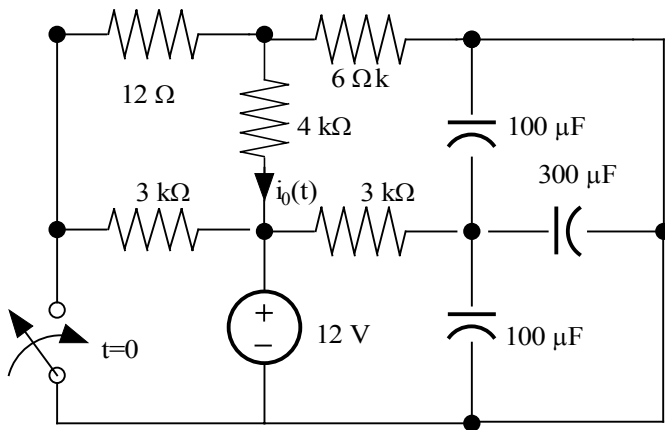

$$R_1 = 12k\Omega$$

$$R_2 = R_4 = 3k\Omega$$

$$R_3 = 4k\Omega$$

$$R_5 = 6k\Omega$$

$$c = 300\mu + 100\mu + 100\mu = 500\mu F$$

for

$$t = 0^-$$

$$i_4 = 0$$

$$v_c = -12v$$

for

$$t = 0^+$$

$$v_c = -12v$$

$$i_4 = 0$$

$$i_0 = \frac{-12}{R_3 + (R_1 \parallel R_5)} = -1.5mA$$

for

$$t \rightarrow \infty$$

$$i_4 = 0$$

$$v_c = -12v$$

$$i_0 = \frac{-12}{R_3 + (R_1 \parallel R_5)} = -1.5mA$$

$$i_0 = -1.5mA$$

Problem 6.54

Find $i_0(t)$ for $t > 0$ in the circuit in Fig. P6.54 using the step-by-step technique.

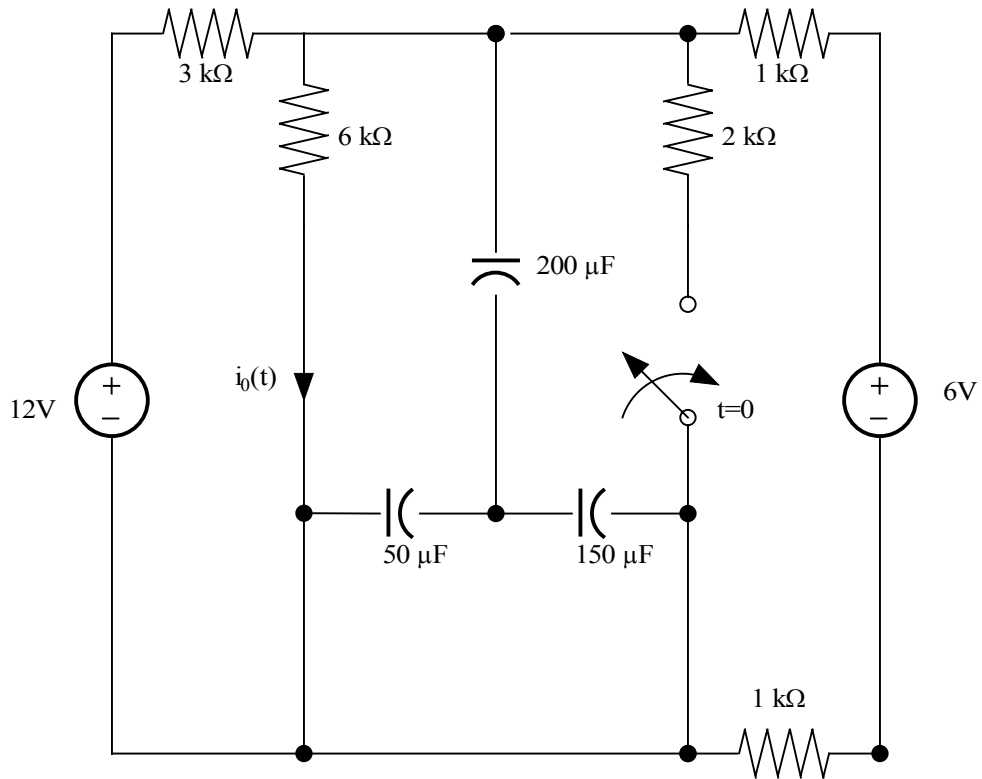

Suggested Solution

$$R_1 = 3k\Omega, R_2 = 6k\Omega, R_3 = 2k\Omega = R$$

$$c = 100\mu F$$

for

$$t \rightarrow \infty$$

$$i_0 = 12 \left[\frac{1}{R_1 + (R_2 \parallel R_3 \parallel R)} \right] \left(\frac{R_3 \parallel R}{R_3 \parallel R + R_2} \right)$$

$$- 6 \left[\frac{1}{R_1 + (R_1 \parallel R \parallel R_2)} \right] \left(\frac{R_1 \parallel R_3}{R_1 \parallel R_3 + R_2} \right)$$

$$i_0 = \frac{1}{9} mA = k_1$$

$$k_2 = \frac{1}{18} mA$$

for

$$t = 0^-$$

$$v_c = 12 \left[\frac{R_1 \parallel R_2}{R \parallel R_2 + R_1} \right] - 6 \left[\frac{R_1 \parallel R_2}{R_1 \parallel R_2 + R} \right]$$

$$v_c = 1v = v_c(0^+)$$

for

$$t = 0^+$$

$$i_0 = \frac{v_c}{R_2} = \frac{1}{6} mA$$

$$\tau = c[R_1 \parallel R_2 \parallel R_3 \parallel R] = \frac{1}{15} \text{sec}$$

$$i_0 = \frac{1}{9} + \frac{1}{18} e^{-15t} mA$$

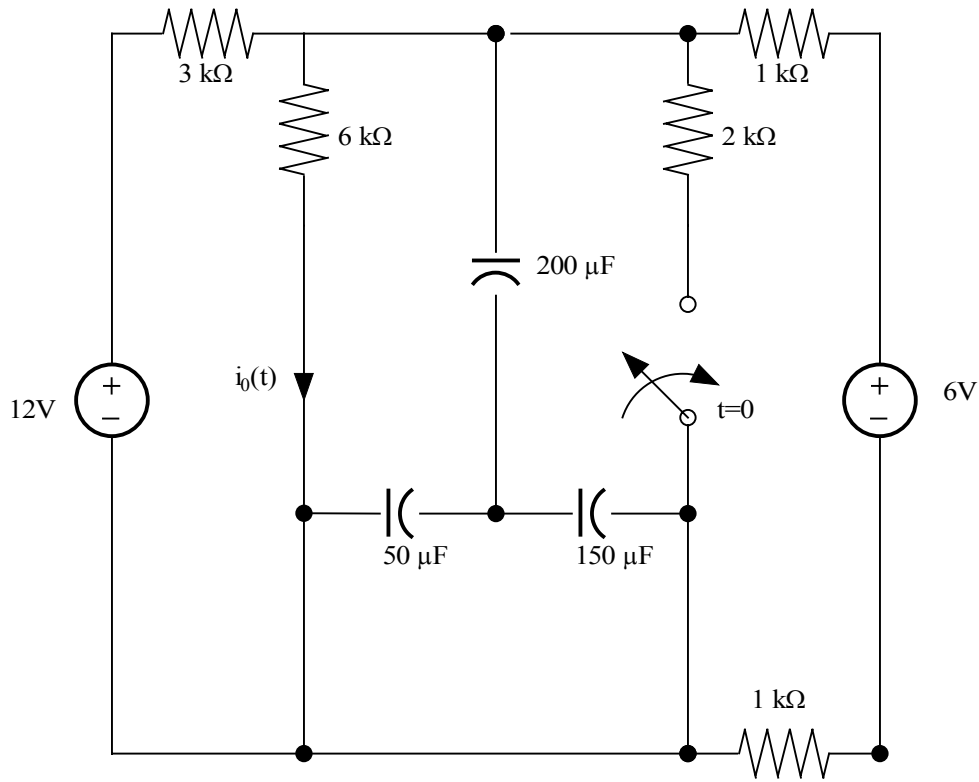

Problem 6.55

The differential equation that describes the current $i_0(t)$ in a network is

$$\frac{d^2 i_0(t)}{dt^2} + 6 \left[\frac{di_0(t)}{dt} \right] + 8i_0(t) = 0$$

Find

- (a) The characteristic equation of the network.
- (b) The network's natural frequencies.
- (c) The expression for $i_0(t)$

Suggested Solution

$$\frac{d^2 i_0(t)}{dt^2} + 6 \left[\frac{di_0(t)}{dt} \right] + 8i_0(t) = 0$$

- (a) The characteristic equation is $S^2 + 6S + 8 = 0$
- (b) The natural frequencies are
 $S = -2$ and $S = -4$
- (c) $i_0(t) = K_1 e^{-2t} + K_2 e^{-4t}$

Problem 6.56

The terminal current in a network is described by the equation

$$\frac{d^2i_0(t)}{dt^2} + 10\left[\frac{di_0(t)}{dt}\right] + 25i_0(t) = 0$$

Find

- The characteristic equation of the network.
- The network's natural frequency.
- The equation for $i_0(t)$.

Suggested Solution

$$i_0(t): \frac{d^2i_0(t)}{dt^2} + 10\left[\frac{di_0(t)}{dt}\right] + 25i_0(t) = 0$$

- The characteristic equation is $S^2+10S+25=0$
- The natural frequency is $S=-5$
- $i_0(t)=K_1e^{-5t}+K_2e^{-5t}$

Problem 6.57

The voltage $v_1(t)$ in a network is defined by the equation

$$\frac{d^2 i_0(t)}{dt^2} + 10 \left[\frac{di_0(t)}{dt} \right] + 25 i_0(t) = 0$$

Find

- The characteristic equation of the network.
- The circuit's natural frequencies.
- The expression for $v_1(t)$.

Suggested Solution

$$i_0(t): \frac{d^2 i_0(t)}{dt^2} + 10 \left[\frac{di_0(t)}{dt} \right] + 25 i_0(t) = 0$$

- The characteristic equation is $S^2 + 2S + 5 = 0$.
- The natural frequencies are
 $S = -1 + 2j$, $S = -1 - 2j$
- $v_1(t) = K_1 e^{-t} \cos 2t + K_2 e^{-t} \sin 2t$.

Problem 6.58

The output voltage of a circuit is described by the differential equation

$$\frac{d^2v_0(t)}{dt^2} + 6\left[\frac{dv_0(t)}{dt}\right] + 10v_0(t) = 0$$

Find

- The characteristic equation for the circuit.
- The network's natural frequencies.
- The equation for $v_0(t)$.

Suggested Solution

$$\frac{d^2v_0(t)}{dt^2} + 6\left[\frac{dv_0(t)}{dt}\right] + 10v_0(t) = 0$$

- The characteristic equation $S^2 + 6S + 10 = 0$.
- Natural frequencies are $S = -3 + \delta$, $S = -3 - 8$.
- $v_0(t) = K_1 e^{-3t} \cos t + K_2 e^{-3t} \sin t$

Problem 6.59

The parameters for a parallel RLC circuit are $R = 1\ \Omega$, $L = 1/5\ \text{H}$, and $C = 1/4\ \text{F}$. Determine the type of damping exhibited by the circuit.

Suggested Solution

What type of damping occurs in this network?

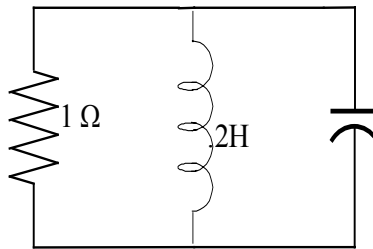

Characteristic Equation:

$$S^2 + \frac{1S}{RC} + \frac{1}{LC} = 0 = S^2 + 4S + 20$$

The Roots are $S = -1 \pm 4j$ which are complex conjugates. The network is underdamped.

Problem 6.60

A series RLC circuit contains a resistor $R = 2\Omega$ and a capacitor $C = 1/x$ F.
Select the value of the inductor so that the circuit is critically damped.

Suggested Solution

What inductance cause critical damping?

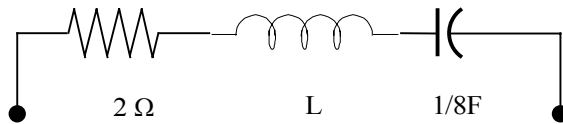

$$\text{If } S^2 + \frac{R}{L}S + \frac{1}{L_c} = 0$$

$$S^2 + \frac{2}{L}S + \frac{8}{L} = 0 \text{ with roots } S = \frac{-2 \pm \sqrt{4 - \frac{32}{L}}}{2}$$

$$\text{for critical damping } \frac{4}{L^2} - \frac{32}{L} = 0.$$

$$\boxed{L = \frac{1}{8} \text{ H}}$$

Problem 6.61

For the underdamped circuit shown in Fig. 6.61 determine the voltage $v(t)$ if the initial conditions on the storage elements are $i_L(0)=1$ A and $v(0) = 10$ V.

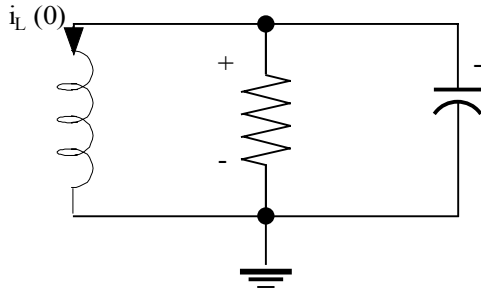

Suggested Solution

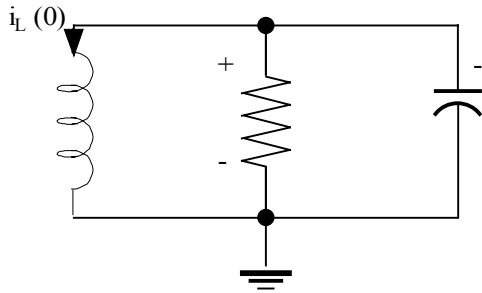

Find $V(t)$ if $i_L(0)=1$ A and $v_c(0)=10$ v

$$\frac{d^2v(t)}{dt^2} + \frac{1}{RC} \frac{dv(t)}{dt} + \frac{1}{LC} v(t) = 0$$

The characteristic equation is

$$s^2 + 8s + 20 = 0$$

$$s = -4 \pm 2j$$

so

$$v(t) = k_1 e^{-4t} \cos 2t + k_2 e^{-4t} \sin 2t$$

at

$$t = 0, v_c = 10$$

$$v(t) = k_1 = 10$$

then

$$\frac{dv(t)}{dt} = -2k_1 e^{-4t} \sin 2t - 4k_1 e^{-4t} \cos 2t + 2k_2 e^{-4t} \cos 2t - 4k_2 e^{-4t} \sin 2t$$

at

$$t = 0$$

$$\frac{dv(t)}{dt} = -4k_1 + 2k_2 = -40 + 2k_2$$

also

$$\frac{cdv(t)}{dt} + \frac{v(t)}{R} + i_L(t) = 0$$

at

$$t = 0$$

$$\frac{dv(t)}{dt} = \frac{1}{c} \left(\frac{-v(t)}{R} - i_L(t) \right) = \frac{1}{c} \left(\frac{-10}{R} - 1 \right)$$

if

$$-40 + 2k_2 = -120$$

finally

$$v(t) = 10e^{-4t} \cos 2t - 40e^{-4t} \sin 2t$$

Problem 6.62

Given the circuit and the initial conditions of Problem 6.61, determine the current through the inductor.

Suggested Solution

Find $i_L(t)$ for the circuit

The network is Underdamped

$$i_L(t) = k_3 e^{-4t} \cos 2t + k_4 e^{-4t} \sin 2t$$

at

$$t = 0$$

$$i_L = k_3 = 1A$$

$$\frac{di_L(t)}{dt} = -2k_3 e^{-4t} \sin 2t - 4k_3 e^{-4t} \cos 2t + 2k_4 e^{-4t} \cos 2t - 4k_4 e^{-4t} \sin 2t$$

at

$$t = 0$$

$$\frac{di_L(t)}{dt} = -4k_3 + 2k_4 = -4 + 2k_4$$

since

$$v(t) = L \frac{di_L(t)}{dt}, \frac{di_L(t)}{dt} = \frac{v(0)}{L} = 5$$

so

$$k_4 = \frac{1}{2}(5 + 4 \times 3) = \frac{9}{2}$$

$$i_L(t) = e^{-4t} \cos 2t + \frac{9}{2} e^{-4t} \sin 2t$$

Problem 6.63

Find $v_C(t)$ for $t > 0$ in the circuit in Fig. P6.63 if $v_C(0) = 0$.

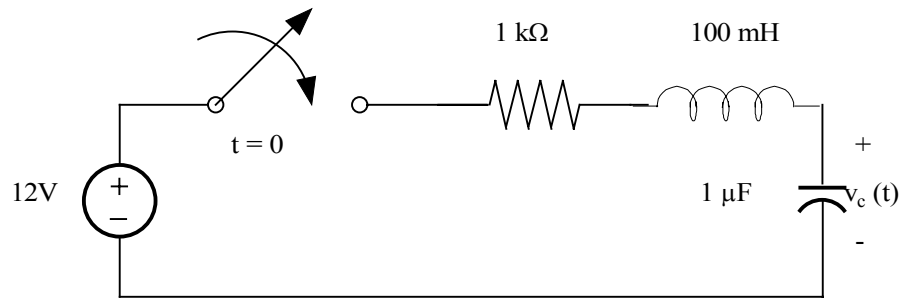

Suggested Solution

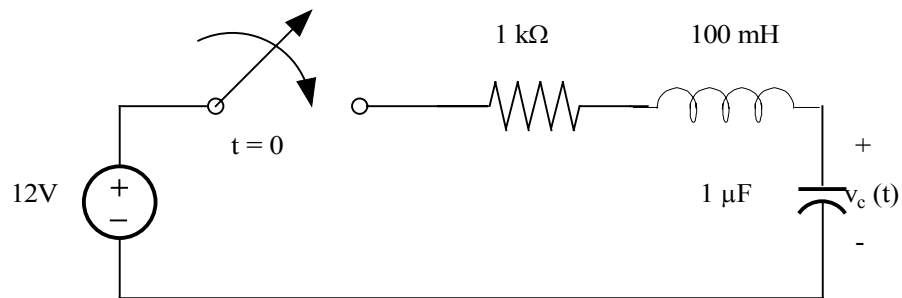

$$R = 1k\Omega, c = 1\mu F, L = 100mH$$

for

$$t = 0^-$$

$$v_0 = 0$$

$$i_L = 0$$

for

$$t = 0^+$$

$$v_0 = 0, i_L = 0$$

for

$$t > 0$$

series RLC with constant forcing function

char_eq

$$s^2 + \frac{R}{L}s + \frac{1}{LC} = 0$$

$$s^2 + 10^4 s + 10^7 = 0$$

Roots_are

$$s_1 = -1127 \frac{-r}{s}, s_2 = -8873 \frac{r}{s} \Rightarrow \text{overdamped}$$

solution is

$$i_L(t) = k_1 e^{s_1 t} + k_2 e^{s_2 t} + k_3$$

$$i_L(0^+) = 0 = k_1 + k_2 + k_3 = 0$$

$$i_L(\infty) = 0 = k_3$$

$$k_2 = -k_1$$

$$i_L(t) = k_1 (e^{s_1 t} - e^{s_2 t})$$

KVL

$$12 = R i_L(t) + L \frac{di_L(t)}{dt} + v_0(t)$$

at

$$t = 0$$

$$12 = R(0) + L[s_1 e^0 - s_2 e^0]k_1 + 0 \Rightarrow k_1 = 15.5mA$$

now

$$i_L(t) = 15.5(e^{s_1 t} - e^{s_2 t})mA$$

$$v_0(t) = \frac{1}{c} \int i_L(t) = \frac{15.5}{100} \frac{1}{10^{-6}} \left[\frac{e^{s_1 t}}{s_1} - \frac{e^{s_2 t}}{s_2} \right] + k$$

$$v_0(\infty) = 12 = k$$

$$v_0(t) = 12 - 13.75e^{-1127t} + 1.75e^{-8875t} \quad t > 0$$

$$v_0(t) = 0 \quad t \leq 0$$

Problem 6.64

Find $v_0(t)$ for $t > 0$ in the circuit in Fig. P6.64 and plot the response including the time interval just prior to moving the switch.

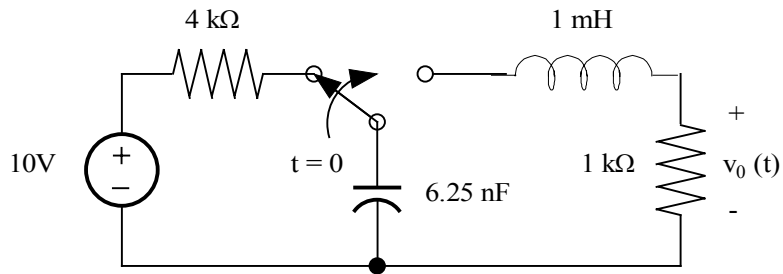

Suggested Solution

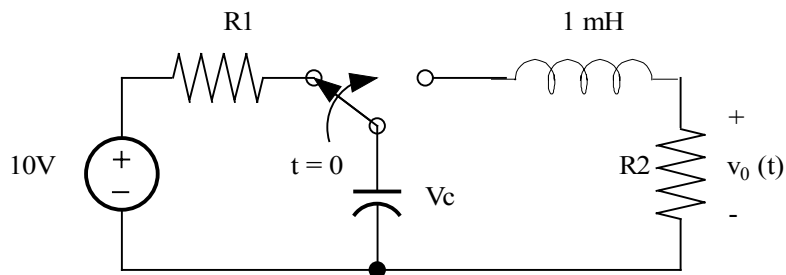

$$R_1 = 4k\Omega, R_2 = 1k\Omega, L = 1mH$$

$$c = 6.25nF$$

for

$$t = 0^-$$

$$v_0 = 0$$

$$i_L = 0, v_c = 10v$$

for

$$t = 0^+$$

$$v_0 = 0, i_L = 0, v_c = 10v$$

for

$$t > 0$$

series RLC with constant forcing function

char _ eq

$$s^2 + \frac{R_2}{L}s + \frac{1}{LC} = 0 \Rightarrow s^2 + 10^6 s + 1.6 \times 10^{11} = 0$$

roots _ are

$$s_1, s_2 = -2 \times 10^5 \text{ and } -8 \times 10^5 \text{ r / s}$$

overdamped

$$v_0(t) = k_1 e^{s_1 t} + k_2 e^{s_2 t}$$

at

$$t = 0^+$$

$$v_0(0^+) = 0 = k_1 + k_2$$

$$k_2 = -k_1$$

also

at

$$t = 0^+$$

$$v_c(0^+) = L \frac{dv_0/dt}{R_2} \Big|_{t=0} + v_0(0^+) = 10v$$

or

$$10^{-6} k_1 [s_1 - s_2] = k_1 (0.6) = 10 \Rightarrow k_1 = 16.67$$

$$v_0(t) = 0v \quad t < 0$$

$$v_0(t) = 16.67 [e^{-2 \times 10^5 t} - e^{-8 \times 10^5 t}] v \quad t \geq 0$$

Problem 6.65

Find $v_c(t)$ for $t > 0$ in the circuit in Fig. P6.65.

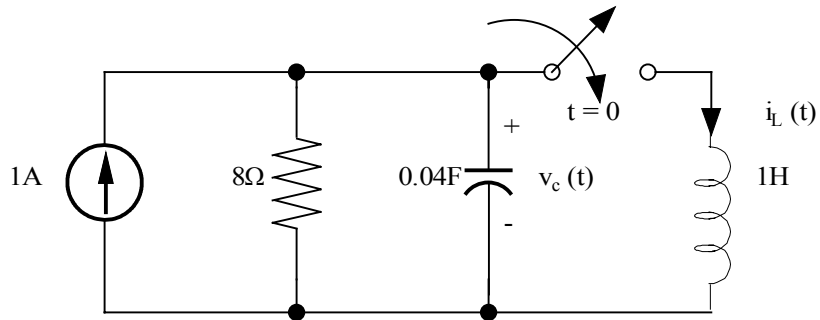

Suggested Solution

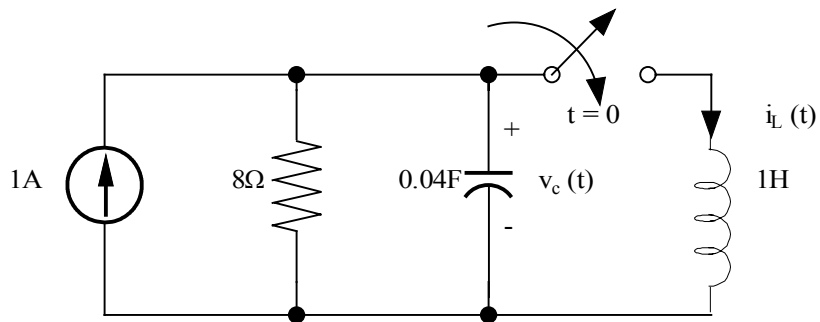

$$R = 8\Omega, c = 40mF, L = 1H$$

for

$$t = 0^-$$

$$i_L = 0, i_R = 1A, v_c = 8v, i_c = 0$$

for

$$t = 0^+$$

$$i_L = 0, i_R = 1A, v_c = 8v, i_c = 0$$

for

$$t = \infty$$

$$i_L = 1, v_c = 0$$

Parallel RLC char eq is

$$s^2 + \frac{1}{RC}s + \frac{1}{LC} = 0$$

roots

$$s_1, s_2 = -1.56 \pm j4.75$$

system is underdamped and

$$v_c(t) = e^{\sigma t} (A \cos \omega t + B \sin \omega t) + k$$

where

$$\sigma = -1.56$$

$$\omega = 4.75$$

$$v_c(0^+) = 8 = A + K$$

and

$$v_c(\infty) = 0 = k$$

$$A = 8$$

by

KCL

at

$$t = 0^+$$

$$1 = \frac{v_c(0^+)}{R} + i_L(0^+) + c \frac{dv_c(t)}{dt} \Big|_{t=0^+} = 1 + 0 + c \frac{dv_c(t)}{dt} \Big|_{t=0}$$

so

$$\frac{dv_c(t)}{dt} \Big|_{t=0} = 0 = B\omega + \sigma A \Rightarrow B = \frac{-\sigma A}{\omega} = 2.63$$

$$v_c(t) = e^{-1.56t} [8 \cos(4.75t) + 2.63 \sin(4.75t)]v \quad t > 0$$

$$v_c(t) = 8v \quad t \leq 0$$

Problem 6.66

Find $i_L(t)$ for $t > 0$ in the circuit in Fig. 6.65.

Suggested Solution

From problem 6.65 for $t > 0$

$$v_c(t) = e^{-1.56t} [8 \cos \omega t + 2.63 \sin \omega t]$$

where

$$\omega = 4.75 \text{ rad/s}$$

KCL :

$$1 = \frac{v_c(t)}{R} + c \frac{dv_c(t)}{dt} + i_L(t)$$

$$i_L(t) = 1 - e^{-1.56t} [\cos \omega t + 0.329 \sin \omega t] + [1.52 \sin \omega t - 0.5 \cos \omega t] e^{-1.56t} + 1.56 e^{-1.56t} [8 \cos \omega t + 2.63 \sin \omega t]$$

$$i_L(t) = 1 + e^{-1.56t} [10.98 \cos(4.75t) + 5.29 \sin(4.75t)] A$$

Problem 6.67

Given the circuit in Fig. 6.67, find the equation for $i(t)$, $t > 0$.

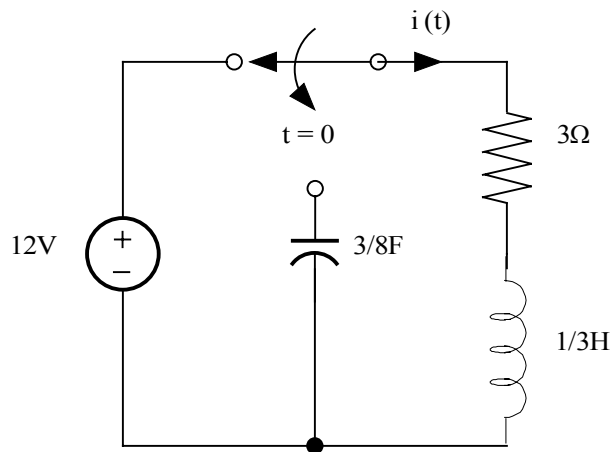

Suggested Solution

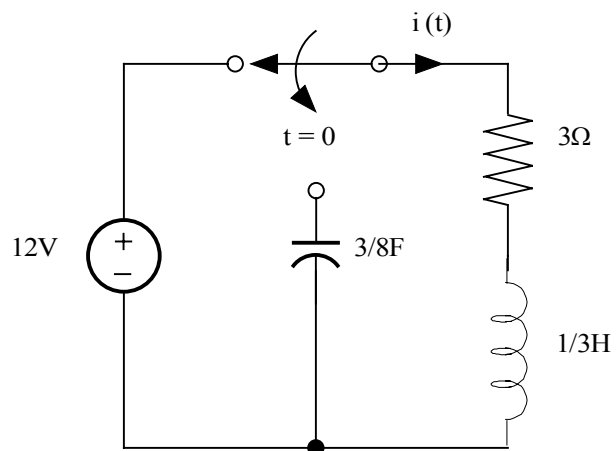

for

$$t < 0$$

$$i_L = 12/3 = 4A, v_c = 0V$$

for

$$t = 0^+$$

$$i_L = 4A, v_c = 0V$$

for

$$t > 0$$

Series RLC circuit

$$s^2 + \frac{R}{L}s + \frac{1}{LC} = 0 \Rightarrow s^2 + 9s + s = 0 \Rightarrow (s+8)(s+9) = 0$$

since roots are real and unequal, overdamped and

$$i(t) = k_1 e^{-t} + k_2 e^{-8t}$$

$$i(0) = 4 = k_1 + k_2$$

KCL:

$$v_c(0^+) = Ri(0^+) + L \left. \frac{di(t)}{dt} \right|_{t=0} \Rightarrow 0 = 12 + \frac{1}{3}(-k_1 - 3k_2)$$

so

$$k_1 + k_2 = 4$$

$$k_1 + 8k_2 = 36$$

$$k_1 = \frac{-4}{7}, k_2 = \frac{32}{7}$$

$$i(t) = \frac{32}{7} e^{-8t} - \frac{4}{7} e^{-t} A \quad \text{for } t > 0$$

Problem 6.68

In the circuit shown in Fig. P6.68, find $v(t)$, $t > 0$.

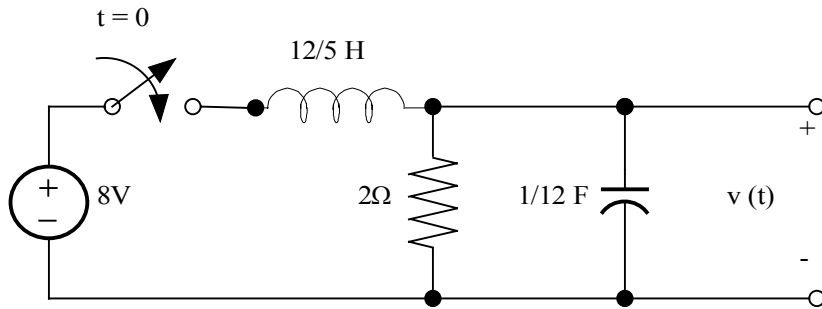

Suggested Solution

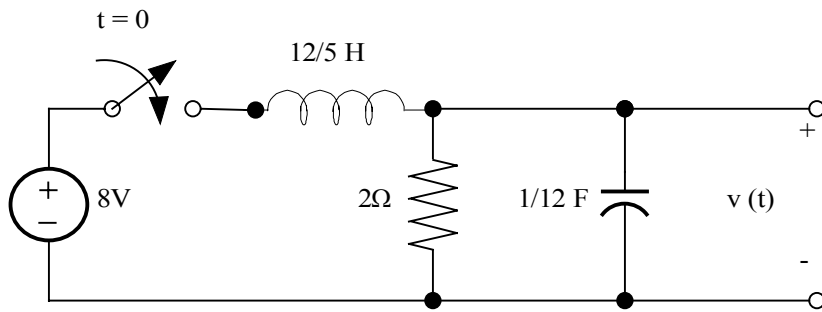

for

$$t = 0^-$$

$$i_L = 0, v_c = v = 0\text{V}$$

for

$$t = 0^+$$

$$i_L = 0, v = 0$$

for

$$t > 0$$

Parallel RLC circuit, char eq is

$$s^2 + \frac{s}{RC} + \frac{1}{LC} = s^2 + 6s + 5 = 0$$

roots are

$$s_1 = -1, s_2 = -5 \Rightarrow \text{overdamped}$$

$$v(t) = k_1 e^{-t} + k_2 e^{-5t} + k_3$$

$$v(0^+) = 0 = k_1 + k_2 + k_3$$

$$v(\infty) = k_3 = 8\text{V}$$

KCL

at

$$t = 0^+$$

$$i_L(0^+) = \frac{v(0^+)}{R} + C \frac{dv(t)}{dt} \Big|_{t=0^+} \Rightarrow \frac{dv(t)}{dt} \Big|_{t=0^+} = 0$$

or

$$-k_1 - 5k_2 = 0$$

$$k_1 + k_2 = -8$$

$$k_1 = -10, k_2 = 2$$

$$v(t) = 8 + 2e^{-5t} - 10e^{-t}\text{V}$$

Problem 6.69

Find $i_0(t)$ for $t > 0$ in the circuit in Fig. P6.69 and plot the response including the time interval just prior to opening the switch.

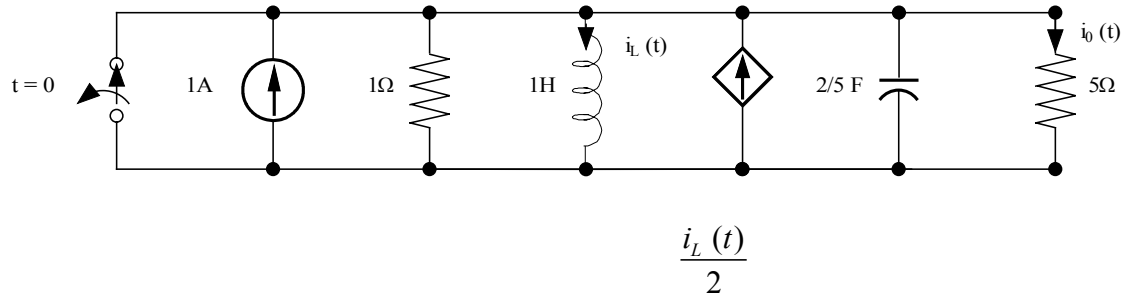

Suggested Solution

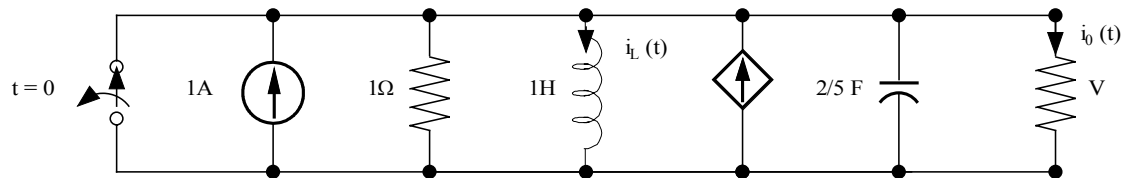

$$R_1 = 1\Omega, R_2 = 5\Omega, L = 1H, c = \frac{2}{3}F$$

for

$$t = 0^-$$

$$i_L = 0, v_c = 0, i_0 = 0, i_{R_1} = i_{R_2} = 0, i_c = 0$$

for

$$t = 0^+$$

$$i_L = 0, v_c = 0, i_0 = 0, i_{R_1} = 0, i_c = 1A$$

for

$$t \rightarrow \infty$$

$$v_c \rightarrow 0, i_0 \rightarrow 0$$

for

$$t > 0$$

KCL:

$$1 = \frac{v}{R_1} + \frac{v}{R_2} + i_c + \frac{i_L}{2}$$

$$1 = v(G_1 + G_2) + c \frac{dv}{dt} + \frac{1}{2L} \int v dt$$

$$i_0 = \frac{v}{R_2}$$

so,

$$25 = 30i_0 + 10 \frac{di_0}{dt} + 12.5 \int i_0 dt \Rightarrow \frac{d^2 i_0}{dt^2} + \frac{3 di_0}{dt} + 1.25 = 0$$

char _ q

$$s^2 + 3s + 1.25 = 0$$

roots _ are

$$s_1 = -0.5, s_2 = -2.5 \Rightarrow \text{overdamped}$$

$$i_0(t) = k_1 e^{-t/2} + k_2 e^{-5t/2} + k_3$$

$$i_0(\infty) = 0 = k_3$$

$$i_0(0^+) = 0 = k_1 + k_2 \Rightarrow k_2 = -k_1$$

$$i_c(0^+) = 1 = k_1 \left(\frac{-1}{2} + \frac{5}{2} \right)$$

so

$$k_1 = \frac{1}{4}A$$

$$i_0(t) = \frac{1}{4}(e^{-t/2} - e^{-5t/2})A$$

Problem 6.70

Find $v_0(t)$ for $t > 0$ in the circuit in Fig. P6.70 and plot the response including the time interval just prior to closing the switch.

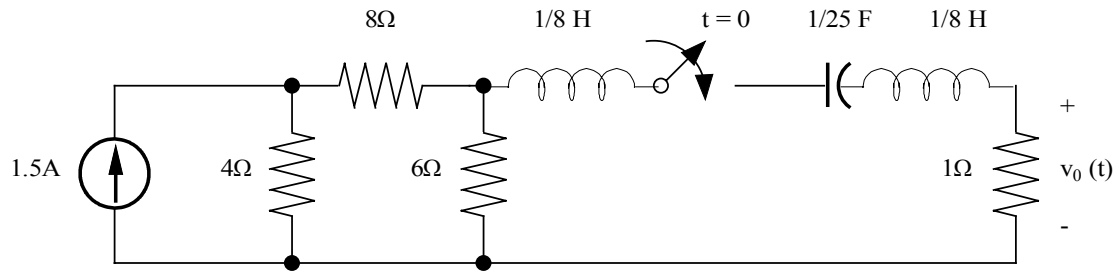

Suggested Solution

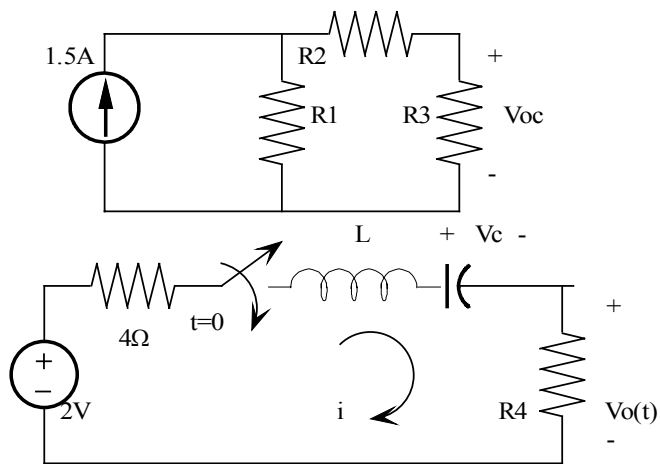
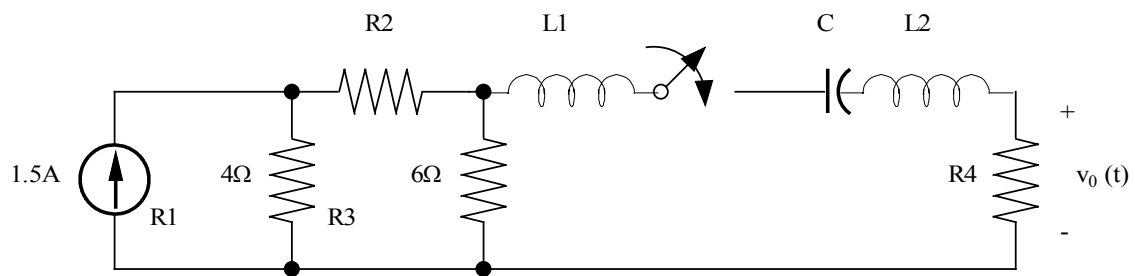

$$R_1 = 4\Omega, R_2 = 8\Omega, R_3 = 6\Omega, R_4 = 1\Omega, L_1 = L_2 = \frac{1}{8}H, c = \frac{1}{25}F$$

$$v_{oc} = 1.5[R_1 \parallel (R_2 + R_3)]\left[\frac{R_3}{R_2 + R_3}\right] = 2.0v$$

$$R_{TH} = (R_1 + R_2) \parallel R_3 = 4\Omega$$

For

$$t = 0^-$$

$$i_L = 0, v_c = 0, v_0 = 0$$

for

$$t = 0^+$$

$$i_L = 0, v_c = 0, v_0 = 0, v_L = 2$$

for

$$t \rightarrow \infty$$

$$v_0 = 0$$

$$L = L_1 + L_2 = \frac{1}{4}H$$

for

$$t > 0$$

series RLC

$$s^2 + \frac{R}{L}s + \frac{1}{LC} = 0$$

$$s^2 + 20s + 100 = 0 \Rightarrow$$

roots :

$$s_1 = s_2 = -10r/s$$

critically_damped

$$v_0(t) = k_1 e^{-10t} + k_2 t e^{-10t} + k_3$$

$$v_0(\infty) = 0 = k_3$$

$$v_0(0^+) = 0 = k_1$$

so

$$v_0 = k_2 t e^{-10t}$$

$$\text{at } t = 0^+$$

$$v_L = 2 = L \left. \frac{di(t)}{dt} \right|_{t=0}$$

$$i(t) = v_0(t) / R_4 = k_2 t e^{-10t}$$

$$2 = L k_2 \Rightarrow k_2 = 8$$

$$v_0 = 8 t e^{-10t} v$$

Problem 6.71

Find $v_0(t)$ for $t > 0$ in the circuit in Fig. P6.71 and plot the response including the time interval just prior to moving the switch.

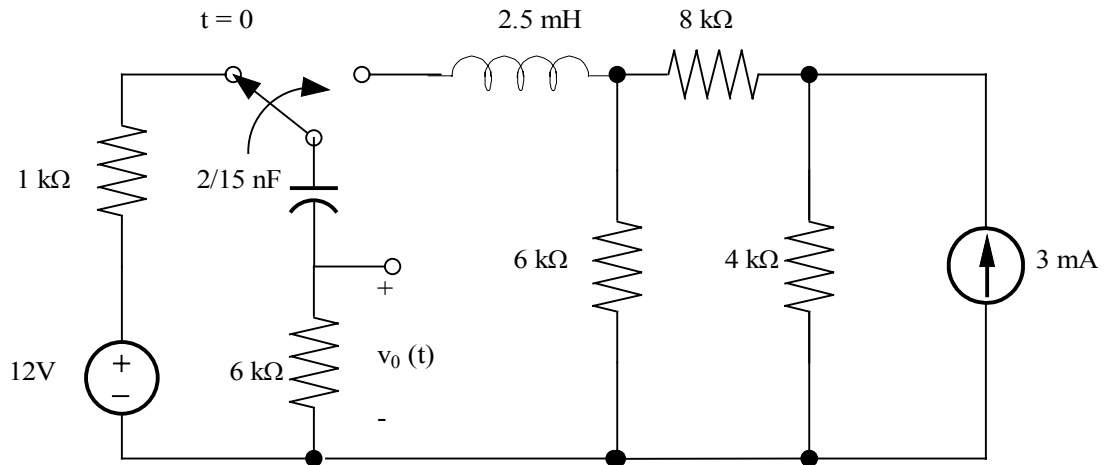

Suggested Solution

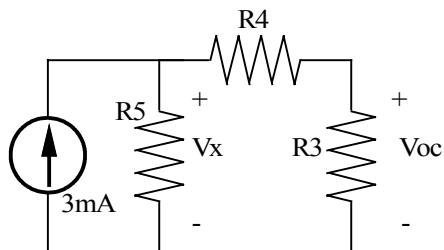
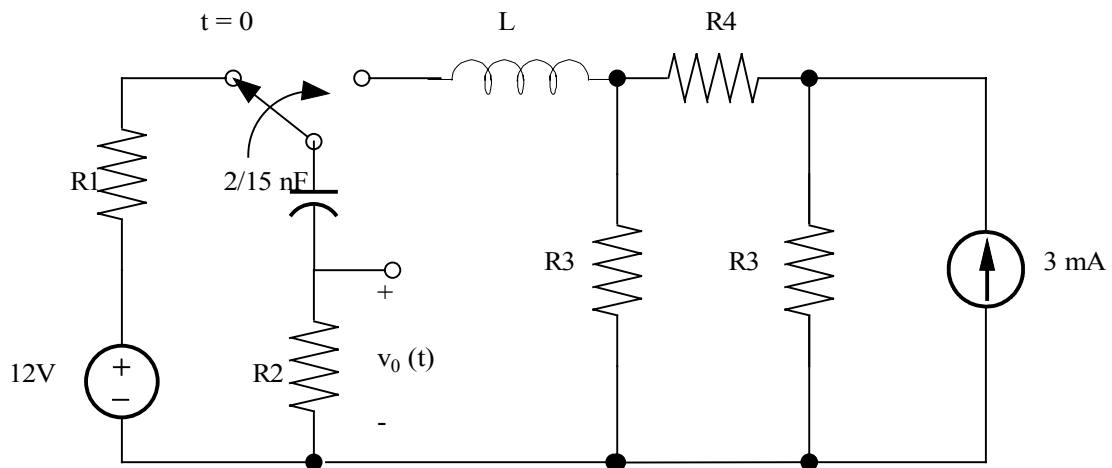

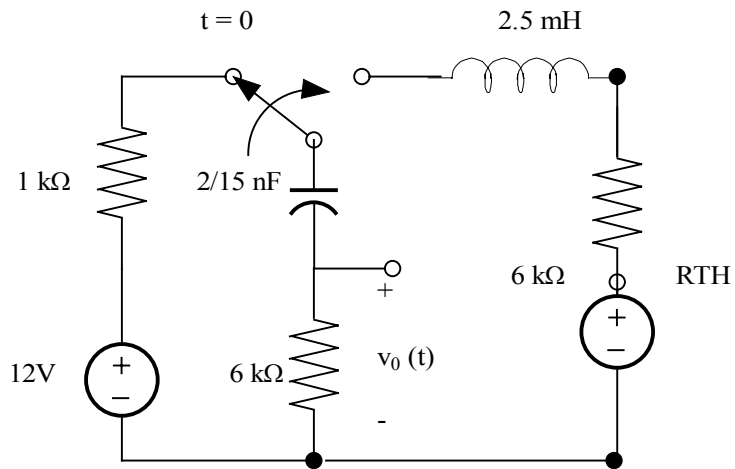

Theve _ eq

$$v_{oc} = \frac{v_x R_3}{R_3 + R_4}$$

$$v_x = 3m[R_s \parallel (R_4 + R_3)]$$

$$R_{TH} = R_s \parallel (R_4 + R_3) = 4k\Omega, v_{oc} = 4v$$

for

$$t = 0^-$$

$$v_c = -12v, v_0 = 0, i_L = 0A$$

for

$$t = 0^+$$

$$v_c = -12v, i_L = 0, v_0 = 0, 4 + v_L = v_c + v_0 \Rightarrow v_L = -16v$$

for

$$t \rightarrow \infty$$

$$v_0 \rightarrow 0$$

for

$$t > 0$$

series RLC circuit

$$s^2 + \frac{R}{L}s + \frac{1}{LC} = 0$$

$$R = R_{TH} + R_2$$

$$s^2 + 4 \times 10^6 s + 3 \times 10^{12} = 0$$

roots _ are

$$s_1 = -1 \times 10^6 \text{ and } s_2 = -3 \times 10^6 \Rightarrow \text{overdamped}$$

$$v_0(t) = k_1 e^{s_1 t} + k_2 e^{s_2 t} + k_3$$

$$v_0(\infty) = 0 = k_3$$

$$v_0(0^+) = 0 = k_1 + k_2 \Rightarrow k_2 = -k_1$$

$$\text{now, } v_0(t) = k_1 (e^{s_1 t} - e^{s_2 t})$$

$$v_L(0^+) = L \left. \frac{di_L}{dt} \right|_{t=0}$$

but

$$i_L(0^+) = \frac{-v_0}{R_L}$$

$$\frac{L}{R_2} k_1 (s_1 - s_2) = 16 \Rightarrow k_1 = 19.2$$

$$v_0(t) = 19.2[e^{-10^6 t} - e^{-3 \times 10^6 t}]V, t > 0$$

$$v_0(t) = 0V, t \leq 0$$

Problem 6.72

Using the PSPICE *Schematics* editor, draw the circuit in Figure P6.72, and use the PROBE utility to plot $v_c(t)$ and determine the time constants for $0 < t < 1 \text{ ms}$ and $1 \text{ ms} < t < \infty$. Also, find the maximum voltage on the capacitor.

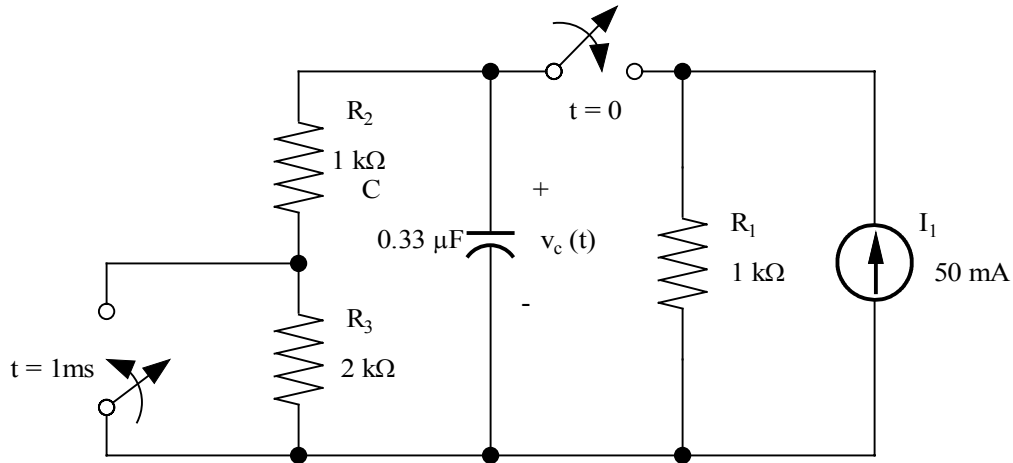

Suggested Solution

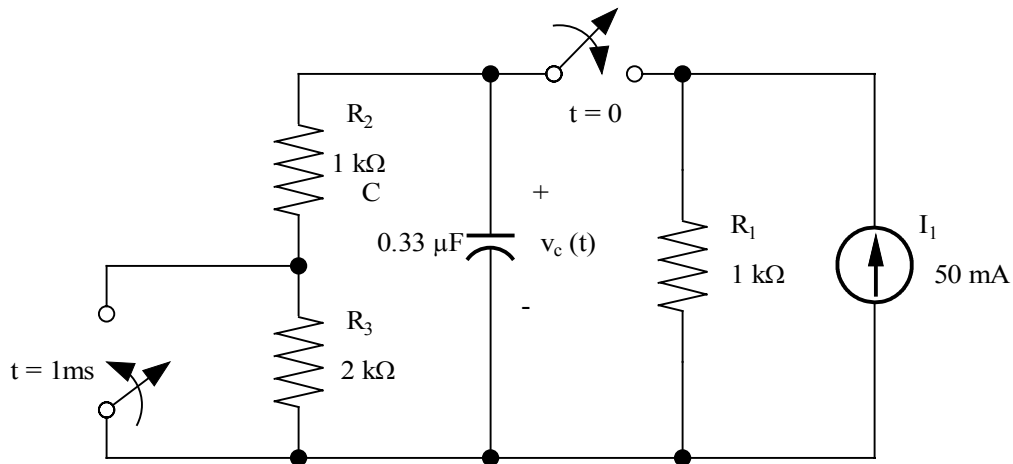

Problem 6.73

Using the PSPICE *Schematics* editor, draw the circuit in Figure P6.73, and use the PROBE utility to find the maximum values of $v_L(t)$, $i_C(t)$, and $i(t)$.

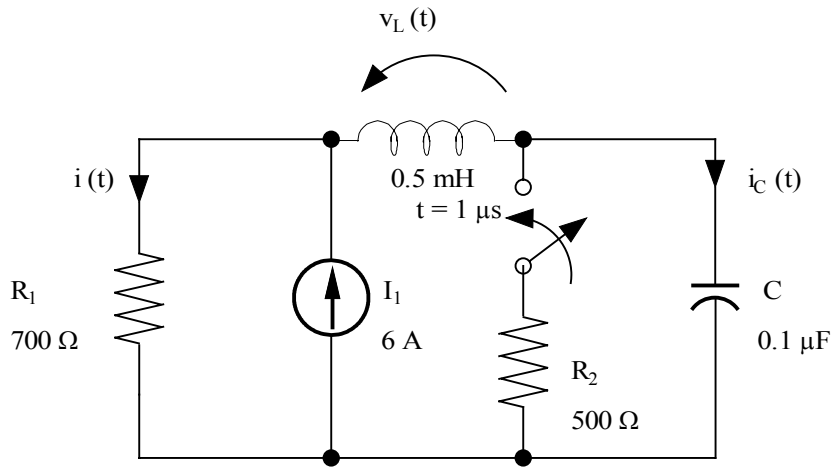

Suggested Solution

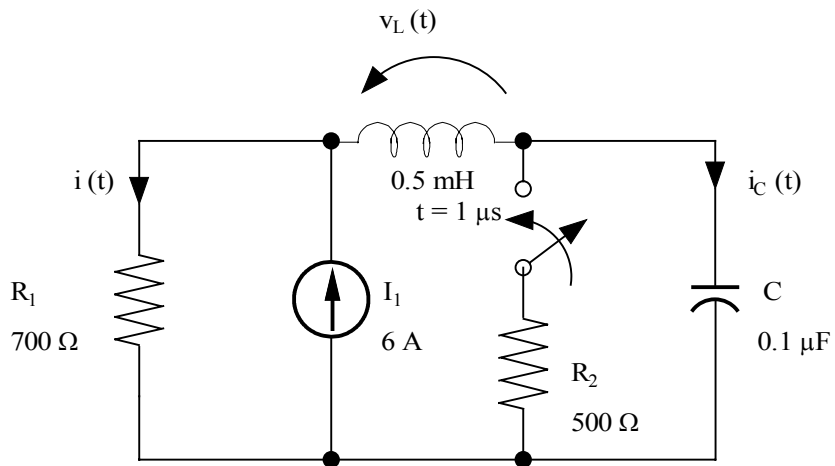

Problem 6.74

Design a series RCL circuit with $R \geq 1\text{K}\Omega$ that has characteristic equation.

$$S^2 + 4 \cdot 10^6 S + 4 \cdot 10^{14} = 0$$

Suggested Solution

Series RLC where $R \geq 1\text{K}\Omega$ and characteristic eq. is,

$$S^2 + \frac{R}{L}S + \frac{1}{LC} = 0 \Rightarrow LC = \frac{10^{-14}}{4}, L = \frac{R}{4 \cdot 10^7}$$

choose $R=40\text{K}\Omega$. Now, $L=1\text{mH}$ & $C=2.5\mu\text{F}$

$$R=40\text{K}\Omega$$

$$L=1\text{mH} \text{ \& } C=2.5\mu\text{F}$$

Problem 6.75

Design a parallel RLC circuit with $R \geq 1 \text{ k}\Omega$ that has the characteristic equation

$$s^2 + 4 \times 10^7 s + 3 \times 10^{14} = 0$$

Suggested Solution

Parallel RLC where $R \geq 1 \text{ k}\Omega$ and characteristic eq. is,

$$s^2 + \frac{s}{RL} + \frac{1}{LC} = 0 \Rightarrow LC = \frac{10^{-14}}{3} \text{ \& } C = \frac{1}{4 \times 10^7 R}$$

choose $R = 2.5 \text{ k}\Omega$. Now, $L = 333 \mu\text{H}$ & $C = 10 \text{ pF}$

$$R = 2.5 \text{ k}\Omega$$

$$L = 333 \mu\text{H} \text{ \& } C = 10 \text{ pF}$$

Problem 6FE-1

In the circuit in Fig the switch, which has been closed for a long time, opens at $t=0$. Find the value of the capacitor voltage $V_c(t)$ at $t=2s$.

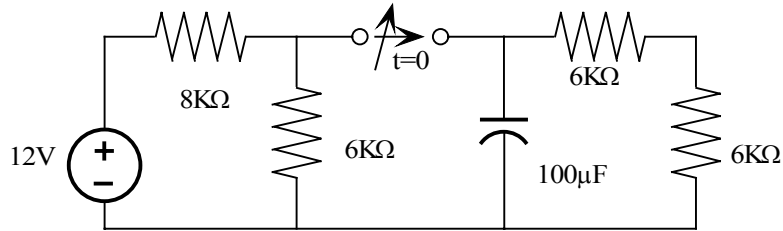

Suggested Solution

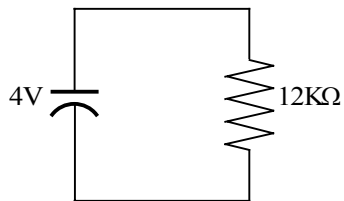
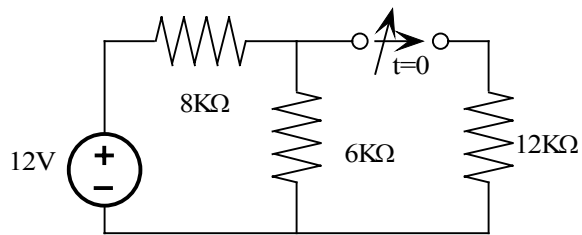

FOR $t < 0$

$$6K \parallel 12K = 4K$$

$$V_c(0) = 12 \left(\frac{4K}{4K + 8K} \right) = 4V$$

$t > 0$ SWITCH OPENS

$$V_c(t) = 4e^{\frac{-t}{\tau}} V$$

$$\tau = 100 * 10^{-6} * 12 * 10^3 = 1.2 \text{ SEC.}$$

$$V_c(t) = 4e^{\frac{-t}{1.2}}$$

AT $t=2$ SEC

$$V_c(t) = 4e^{\frac{-2}{1.2}} = 0.76V$$

Problem 6FE-2

In the network in fig, the switch closes at $t=0$. Find $V_o(t)$ at $t=1s$.

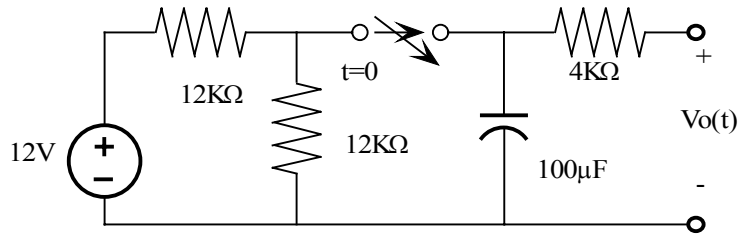

Suggested Solution

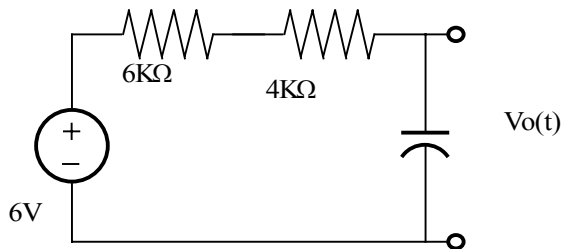
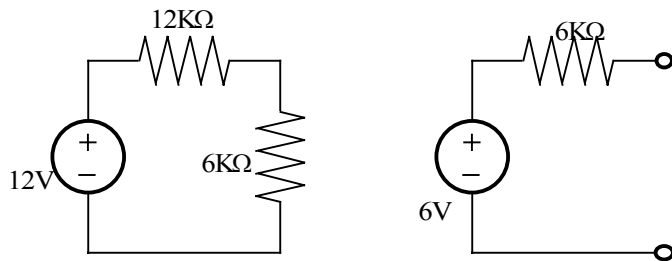

$$V_o(t) = 6(1 - e^{-\frac{t}{\tau}})$$

$$\tau = 10 * 10^3 * 100 * 10^{-6} = 1 \text{ SEC.}$$

$$V_o(t) = 6(1 - e^{-\frac{t}{\tau}}) V$$

AT $t=1 \text{ SEC}$,

$$V_o(t) = 6(1 - e^{-1}) = 3.79 V$$

Problem 6FE-3

Assume the switch, in the network in fig, has been closed for sometime. At $t=0$ the switch opens. Determine the time required for the capacitor voltage to decay to $\frac{1}{2}$ of its initially charged value.

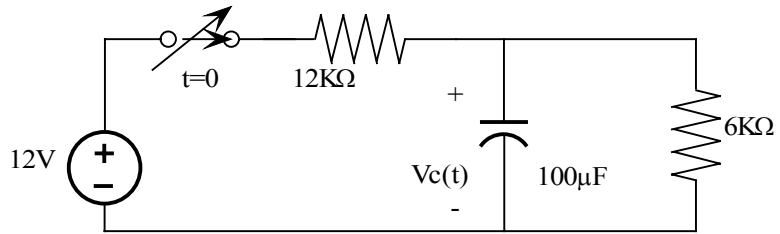

Suggested Solution

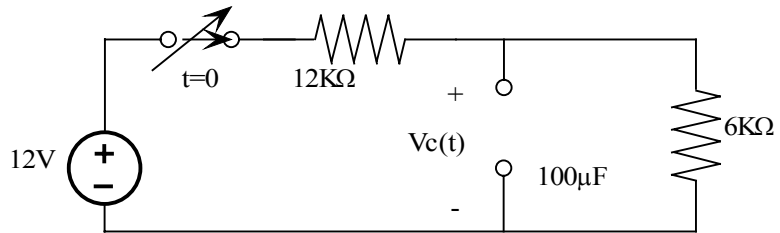

$$V_C(0^-) = 12 \left(\frac{6K}{18K} \right) = 4V$$

$$V_C(t) = 4e^{-\frac{t}{\tau}}$$

$$\tau = 100 * 10^{-6} * 6 * 10^3 = 0.6 \text{ sec.}$$

$$V_C(t) = 4e^{-\frac{t}{0.6}} V$$

$$1/2 \text{ OF INITIAL CHANGE VALUE} = 2 = 4e^{-\frac{t}{0.6}} V$$

$$\therefore \frac{1}{2} = e^{-\frac{t}{0.6}} \Rightarrow t = 0.42 \text{ sec.}$$

Problem 7.1

Given $i(t)=5 \cos(400t - 120^\circ)$ A, determine the period of the current and the frequency in hertz.

Suggested Solution

$$f = \frac{\omega}{2\pi} = \frac{400}{2\pi} = 63.6\text{Hz}$$

$$T = \frac{1}{f} = .016\text{s}$$

Problem 7.2

Determine the relative position of the two sine waves

$$V_1(t) = 12 \sin(377t - 45^\circ)$$

$$V_2(t) = 6 \sin(377t + 675^\circ)$$

Suggested Solution

$V_2(t)$ can be rewritten as $V_2(t) = 6 \sin(377t - 45^\circ)$, so $V_1(t)$ and $V_2(t)$ are in phase. PHASE=0.

Problem 7.3

Given the following currents:

$$\begin{aligned}i_1(t) &= 4 \sin(377t - 10^\circ) \text{ A} \\i_2(t) &= -2 \sin(377t - 195^\circ) \text{ A} \\i_3(t) &= -1 \sin(377t - 250^\circ) \text{ A}\end{aligned}$$

Compute the phase angle between each pair of currents.

Suggested Solution

$i_1(t)$ leads $i_2(t)$ by -85° . $i_2(t)$ leads $i_3(t)$ by 145° . $i_1(t)$ by $i_3(t)$ by 60°

Problem 7.4

Determine the phase angles by which $v_1(t)$ leads $i_1(t)$ and $v_1(t)$ leads $i_2(t)$, where:

$$\begin{aligned}v_1(t) &= 4 \sin(377t + 25^\circ) \\i_1(t) &= 0.05 \cos(377t - 10^\circ) \\i_2(t) &= -0.1 \sin(377t + 75^\circ)\end{aligned}$$

Suggested Solution

$$\begin{aligned}v_1(t) \text{ leads } i_1(t) \text{ by } 25^\circ - 80^\circ &= -55^\circ \\v_1(t) \text{ leads } i_2(t) \text{ by } 25^\circ - 255^\circ &= -230^\circ\end{aligned}$$

Problem 7.5

Calculate the current in the resistor if the voltage input is:

(a) $v_1(t) = 10 \cos(377t + 180^\circ)$

(b) $v_2(t) = 12 \sin(377t + 45^\circ)$

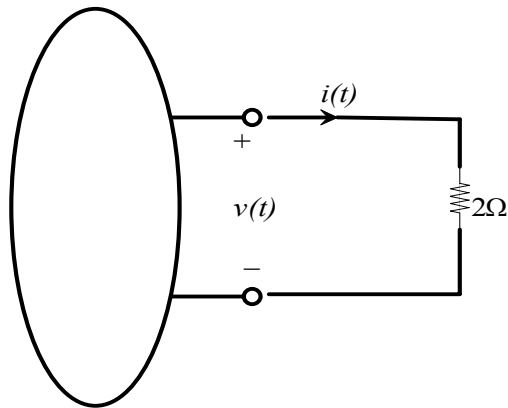

Give the answers in both the time and frequency domains.

Suggested Solution

(a) $i(t) = \frac{v_1(t)}{R} = 5 \cos(377t + 180^\circ) A = 5 \angle 180^\circ A$

(b) $i(t) = \frac{v_2(t)}{R} = 6 \sin(377t + 45^\circ) A = 6 \cos(377t - 45^\circ) A = 6 \angle -45^\circ A$

Problem 7.6

Calculate the current in the capacitor if the voltage input is:

- (a) $v_1(t) = 16 \cos(377t - 22^\circ)$
(b) $v_2(t) = 8 \sin(377t + 64^\circ)$

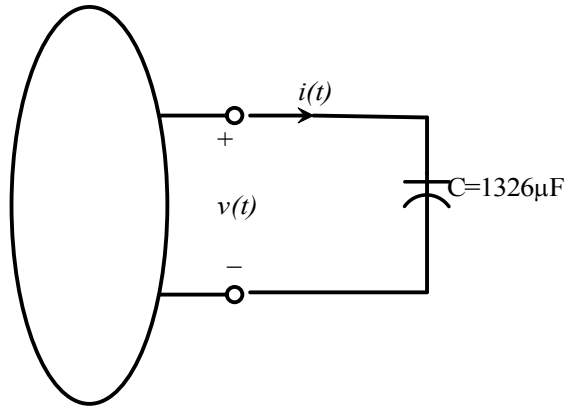

Give the answers in both the time and frequency domains.

Suggested Solution

$$Z_c = \frac{1}{j\omega C} = \frac{1}{j(377)(1326 \times 10^{-6})} = \frac{1}{.5j}$$

(a) $i(t) = \frac{v(t)}{Z_c} = \frac{16 \angle -22^\circ}{2 \angle -90^\circ} = 8 \angle 68^\circ A = 8 \cos(377t + 68^\circ) A$

(b) $i(t) = \frac{v(t)}{Z_c} = \frac{8 \angle 64^\circ}{2 \angle -90^\circ} = 4 \angle 64^\circ A = 4 \cos(377t + 64^\circ) A$

Problem 7.7

Calculate the current in the inductor if the voltage input is:

- (a) $v_1(t) = 24 \cos(377t + 12^\circ)$
(b) $v_2(t) = 18 \sin(377t - 48^\circ)$

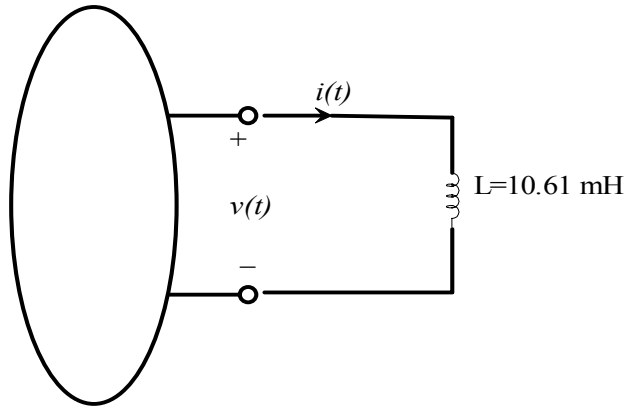

Give the answers in both the time and frequency domains.

Suggested Solution

$$Z_L = j\omega L = j(377)(10.61 \times 10^{-3}) = 4j$$

$$\text{(a)} \quad i(t) = \frac{v(t)}{Z_L} = \frac{24 \angle 12^\circ}{4 \angle 90^\circ} = 6 \angle -78^\circ \text{ A}$$

$$\text{(b)} \quad i(t) = \frac{v(t)}{Z_L} = \frac{18 \angle 42^\circ}{4 \angle 90^\circ} = 4.5 \angle -48^\circ \text{ A}$$

Problem 7.8

Find the frequency domain impedance, Z , for the network shown.

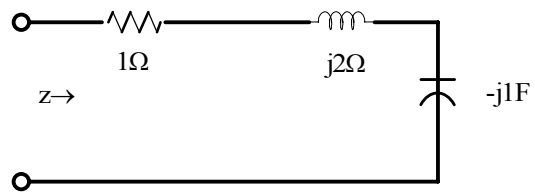

Suggested Solution

$$Z = 1 + j2 - j1 = 1 + j1\Omega$$

Problem 7.9

Find the frequency domain impedance, Z , for the network shown.

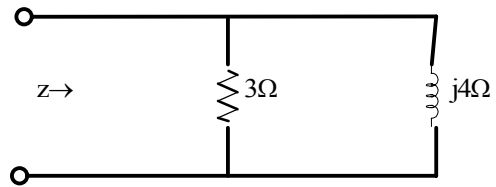

Suggested Solution

$$Z = 3 \parallel j4 = \frac{12j}{3+4j} = \frac{12 \angle 90^\circ}{2.4 \angle 53^\circ} = 2.4 \angle 37^\circ = 1.92 + j1.44 \Omega$$

Problem 7.10

Find the frequency domain impedance, Z , for the network shown.

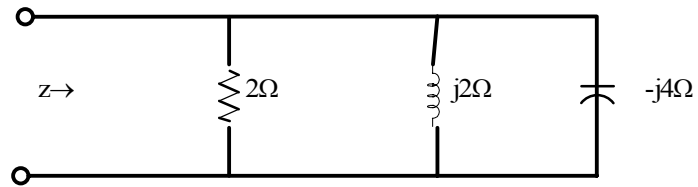

Suggested Solution

$$\frac{1}{Z} = \frac{1}{2} + \frac{1}{j2} - \frac{1}{j4} = \frac{1}{2} - j\left(\frac{1}{2} - \frac{1}{4}\right) = \frac{1}{4}(2 - j)$$

$$Z = \frac{4}{2 - j} = \frac{4(2 + j)}{(2 - j)(2 + j)} = \frac{8 + 4j}{4 + 1} = 1.6 + j0.8$$

$$Z = 1.6 + j0.8\Omega$$

Problem 7.11

Find the frequency domain impedance, Z , for the network shown.

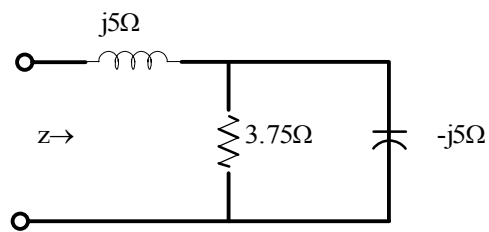

Suggested Solution

$$Z = 5j + (-5j \parallel 3.75) = 5j + \frac{18.75j}{3.75 - 5j} = 5j + \frac{18.74 \angle -90^\circ}{6.25 \angle -53.1^\circ} = 5j + 3 \angle -36.9^\circ = 2.4 + j3.2 = 4 \angle 53^\circ \Omega$$

Problem 7.12

Find the frequency domain impedance, Z , for the network shown.

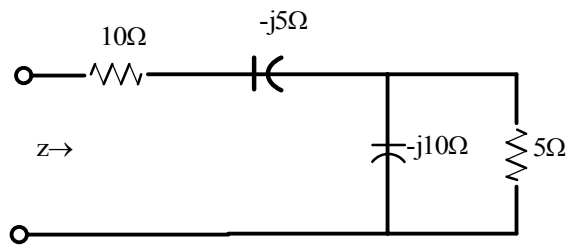

Suggested Solution

$$Z = 10 - 5j + \frac{5(-10j)}{5 - 10j} = 10 - 5j + \frac{5(-10j)}{11.2 \angle -23.4^\circ} = 10 - 5j + 4 - 2j = 14 - 7j = 15.65 \angle -26.6^\circ \Omega$$

Problem 7.13

Find $Z(j\omega)$ at a frequency of 60 Hz for the network shown.

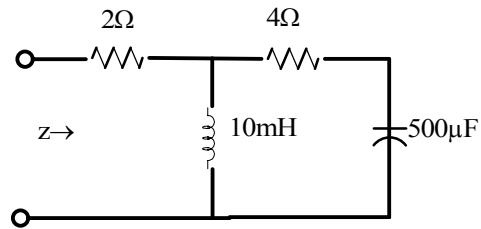

Suggested Solution

$$Z_L = j\omega L = j(377)(10 \times 10^{-3}) = j3.77$$

$$Z_c = \frac{1}{j\omega C} = \frac{10^6}{j377(5)} = -j5.3$$

$$Z = 2 + \frac{j3.77(4 - j5.3)}{j3.77 + 4 - j5.3} = 2 + \frac{j15.08 + 20}{4 - j1.535} = 5.1 + j4.96\Omega$$

Problem 7.14

Calculate the equivalent impedance Z at the terminals A-B for the network shown.

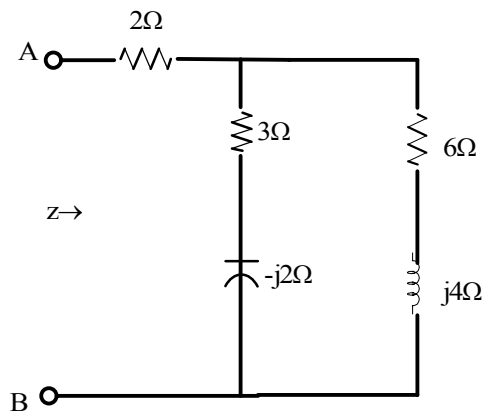

Suggested Solution

$$Z_{AB} = 2 + (3 - 2j) \parallel (6 + 4j) = 2 + \frac{(3 - 2j)(6 + 4j)}{9 + 2j} = \frac{18 + 4j + 26}{9 + 2j} = \frac{44.18 \angle 5.19^\circ}{9.22 \angle 12.53^\circ} = 4.8 \angle -7.34^\circ \Omega$$

Problem 7.15

Find Z for the network shown.

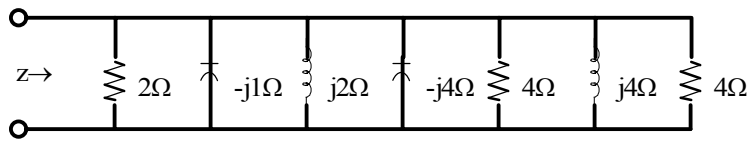

Suggested Solution

$$Y = 1 + \frac{1}{-j} + \frac{1}{-4j} + \frac{1}{2j} + \frac{1}{4j} = 1 + j + .25j - .5j - .25j = 1 + .5j = 1.12 \angle 26.57^\circ$$

$$Z = \frac{1}{Y} = .89 \angle -26.57^\circ \Omega$$

Problem 7.16

Find Z for the network shown.

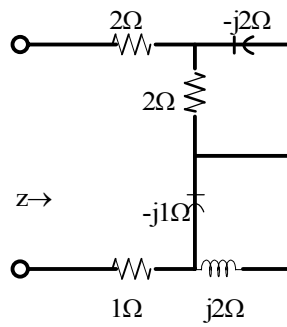

Suggested Solution

$$Z = 2 + 1 + 2 \parallel -2j + 2j \parallel -j = 3 + \frac{-4j}{2-2j} + \frac{2}{j} = 4 - 3j = 5 \angle -37^\circ \Omega$$

Problem 7.17

Find Z for the network shown.

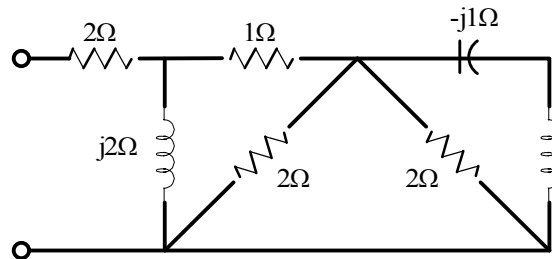

Suggested Solution

$$Z = 2 + 2j \parallel (1 + 1 \parallel j) = 2 + 2j \parallel (1.5 + 0.5j) = 2 + \frac{2j - 4}{-1 + 4j} = 2.83 \angle 16.92^\circ \Omega$$

Problem 7.18

The impedance of the network shown is found to be purely real at $f=60$ Hz. What is the value of C ?

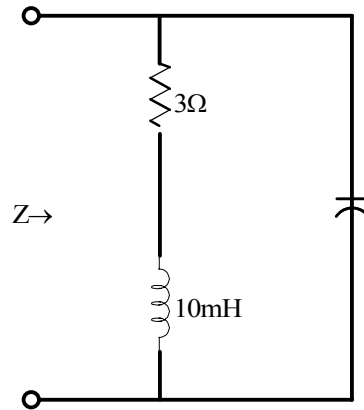

Suggested Solution

$$Z = \frac{1}{j\omega C} \parallel (R + j\omega L) = \frac{\frac{-j}{\omega C}(3 + 3.77j)}{\frac{-j}{\omega C} + 3 + 3.77j} = \frac{\left(\frac{-3j}{\omega C} + \frac{3.77}{\omega C}\right)\left(3 - j\left(3.77 - \frac{1}{\omega C}\right)\right)}{3^2 + \left(3.77 - \frac{1}{\omega C}\right)^2}$$

THE IMAGINARY COMPONENT IS ZERO

$$0 = \frac{-9j}{\omega C} - \frac{3.77j}{\omega C}\left(3.77 - \frac{1}{\omega C}\right) = -9j - 3.77j\left(3.77 - \frac{1}{\omega C}\right)^2$$

$$\omega = 2\pi 60 = 377 \rightarrow C = 431 \mu F$$

Problem 7.19

In the circuit shown determine the value of the inductance such that the current is in phase with the source voltage.

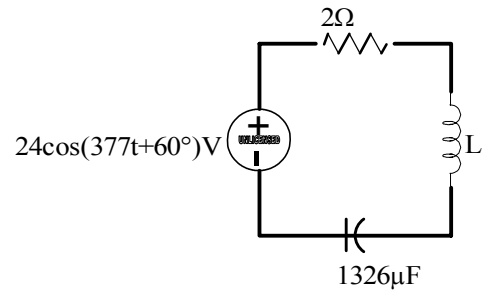

Suggested Solution

$$\omega = 377$$

$$f = 60\text{Hz}$$

$$\omega_L = \frac{1}{\omega C}, L = \frac{1}{\omega^2 C} = \frac{1}{(377^2)(1326 \times 10^{-6})} = 5.3\text{mH}$$

Problem 7.20

Draw the frequency domain circuit and calculate $I(t)$ for the circuit shown if $v_s(t) = 10 \cos(377t + 30^\circ)$ V.

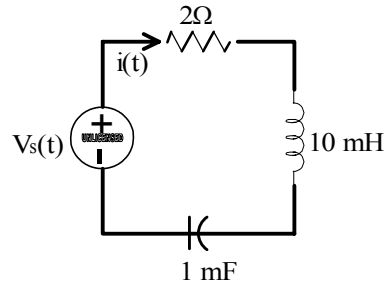

Suggested Solution

$$j\omega L = j(377)(10 \times 10^{-3}) = j3.77\Omega$$

$$\frac{1}{j\omega C} = \frac{-j}{377 \times 10^{-3}} = -j2.65\Omega$$

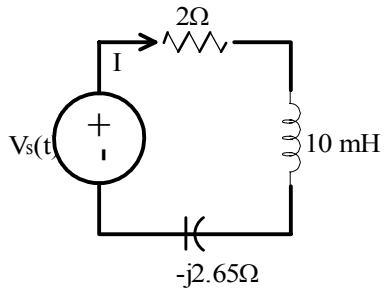

$$I = \frac{V_s}{2 + j3.77 - j2.65} = \frac{10\angle 30^\circ}{2 + j1.12} = \frac{10\angle 30^\circ}{2.29\angle 29.25^\circ} = 4.37\angle 0.75^\circ A$$

$$i(t) = 4.37 \cos(377t + 0.75^\circ) A$$

Problem 7.21

Draw the frequency domain circuit and calculate $v(t)$ for the circuit shown if $i_s(t) = 20 \cos(377t + 120^\circ)$ A.

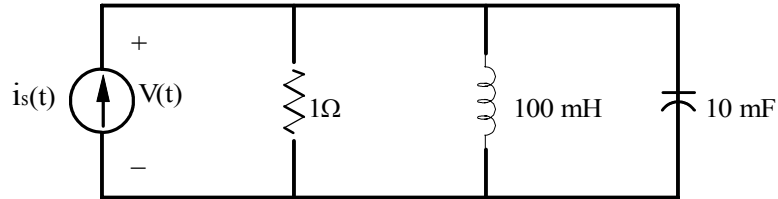

Suggested Solution

$$Z = j\omega L = j37.7\Omega$$

$$Z_c = \frac{1}{j\omega C} = \frac{1}{j3.77}\Omega$$

$$V = I \left[\frac{1}{\frac{1}{R} + \frac{1}{Z_L} + \frac{1}{Z_C}} \right] = \frac{2\angle 120^\circ}{1 - \frac{j}{37.7} + j3.77} = \frac{2\angle 120^\circ}{1 + j3.74} = \frac{2\angle 120^\circ}{3.84\angle 75.03^\circ} = 0.52\angle 44.91^\circ V$$

$$v(t) = 0.52 \cos(377t + 44.97^\circ) V$$

Problem 7.22

The voltages $v_R(t)$, $v_L(t)$, and $v_C(t)$ in the circuit shown can be drawn as phasors in a phasor diagram. Show that $v_R(t) + v_L(t) + v_C(t) = v_S(t)$.

Suggested Solution

$$V_R(t) = i(t)R = 2(4.37) \cos(377t + 0.75^\circ) = 8.74 \cos(377t + 0.75^\circ)V$$

$$V_R = 8.74 \angle 0.75^\circ V$$

$$V_L(t) = L \frac{di}{dt} = (10^{-2})(4.37)(377)(-\sin(377t + 0.75^\circ)) = 16.47 \cos(377t + 90.75^\circ)$$

$$V_L = 16.47 \angle 90.75^\circ V$$

$$V_C(t) = \frac{1}{C} \int i dt = \left(\frac{1}{10^{-3}} \right) \left(\frac{1}{377} \right) (4.37) \sin(377t + 0.75^\circ)$$

$$V_C(t) = 11.59 \cos(377t - 89.25^\circ)V$$

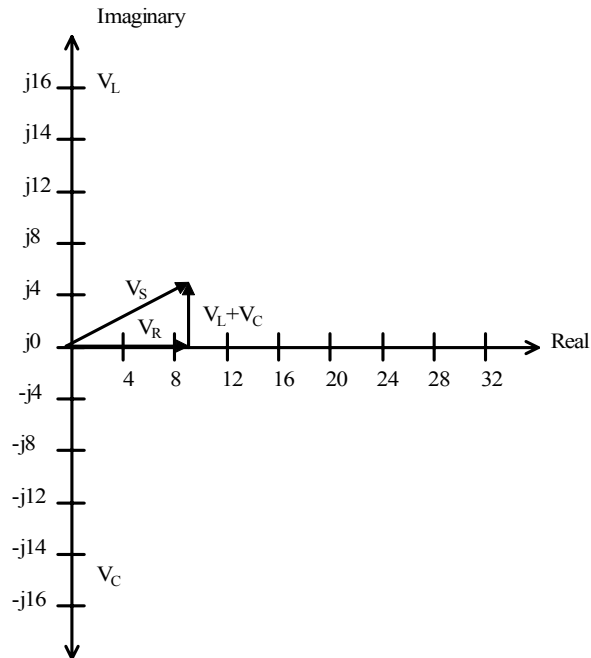

Problem 7.23

The currents $i_R(t)$, $i_L(t)$, and $i_C(t)$ in the circuit shown can be drawn as phasors in a phasor diagram. Show that $i_R(t) + i_L(t) + i_C(t) = i_S(t)$.

Suggested Solution

$$I_R(t) = \frac{V(t)}{R} = 0.52 \cos(377t + 44.97^\circ) A$$

$$I_R = 0.52 \angle 44.97^\circ A$$

$$I_C(t) = C \frac{dv}{dt} = (10^{-2})(0.52)(377)(-\sin(377t + 44.97^\circ)) = 1.96 \cos(377t + 134.97^\circ)$$

$$I_C = 1.96 \angle 134.97^\circ A$$

$$I_L(t) = \frac{1}{L} \int v dt = \left(\frac{0.52}{0.1} \right) \left(\frac{1}{377} \right) \sin(377t + 44.97^\circ) = 13.79 \cos(377t - 45.03^\circ) mA$$

$$I_L(t) = 13.79 \angle -45.03^\circ A$$

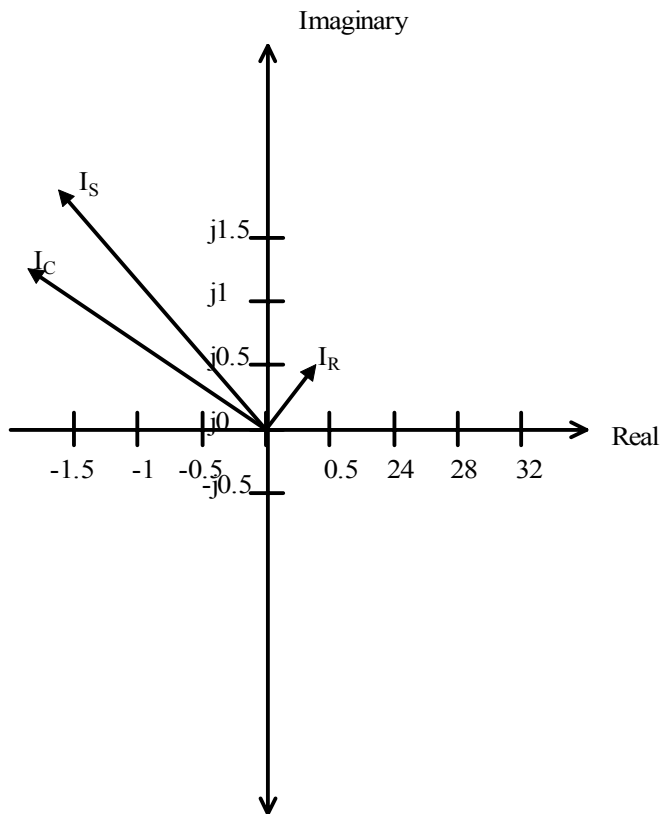

Problem 7.24

The voltages $v_R(t)$ and $v_L(t)$ in the circuit shown can be drawn as phasors in a phasor diagram. Use a phasor diagram to show that $v_R(t) + v_L(t) = v_S(t)$.

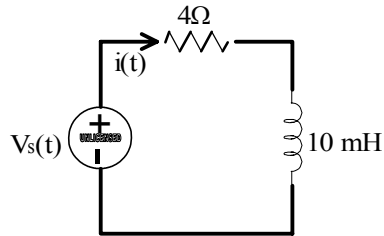

Suggested Solution

$$I = 0.36 \angle -43.38^\circ \text{ A}$$

$$V_R = 4I = 1.44 \angle -43.38^\circ \text{ V}$$

$$V_L = j3.77I = 1.36 \angle 46.62^\circ \text{ V}$$

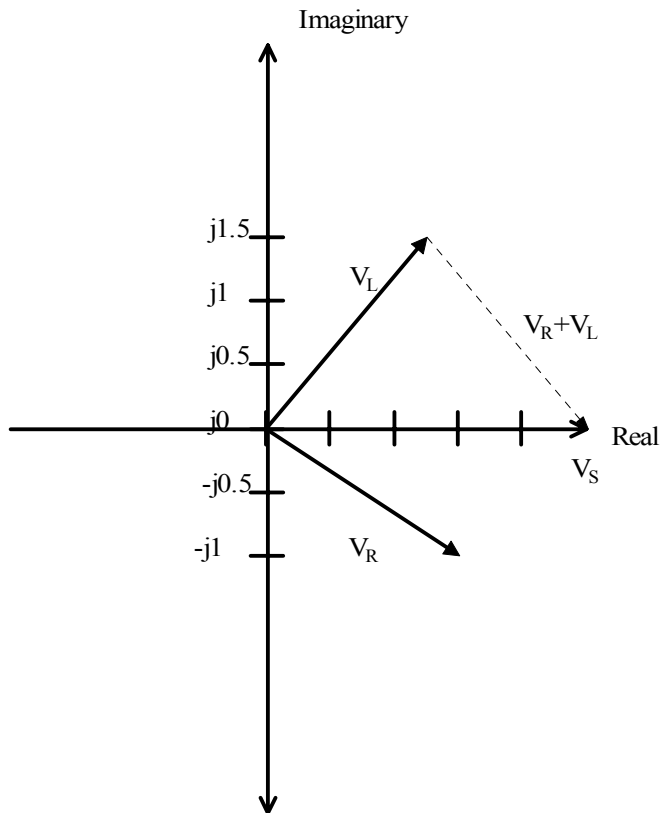

Problem 7.25

The currents $i_R(t)$ and $i_C(t)$ in the circuit shown can be drawn as phasors in a phasor diagram. Use a phasor diagram to show that $i_R(t) + i_C(t) = i_S(t)$.

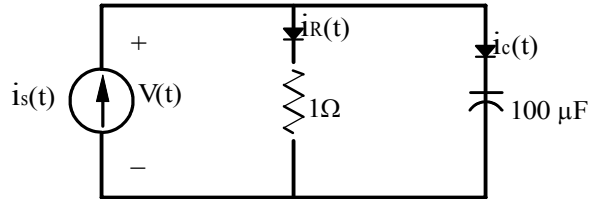

Suggested Solution

$$I_R(t) = \frac{V(t)}{R} = 9.99 \cos(377t + 27.84^\circ) A$$

$$I_R = 9.99 \angle 27.84^\circ A$$

$$I_C(t) = C \frac{dv}{dt} = (10^{-4})(9.99)(377)(-\sin(377t + 27.84^\circ)) = 0.38 \cos(377t + 117.84^\circ)$$

$$I_C = 0.38 \angle 117.84^\circ A$$

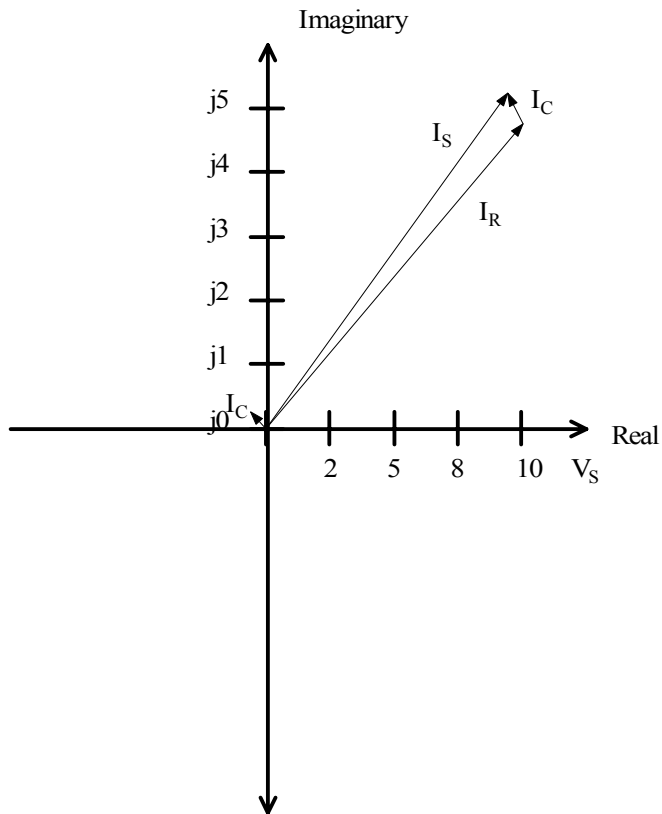

Problem 7.26

The currents $i_L(t)$ and $i_C(t)$ of the inductor and capacitor in the circuit shown can be drawn as phasors in a phasor diagram. Use a phasor diagram to show that $i_L(t) + i_C(t) = i_S(t)$.

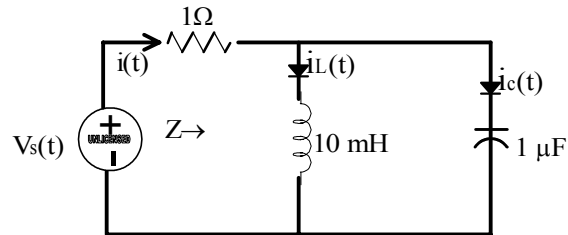

Suggested Solution

$$V = V_S - IR = 10\angle 30^\circ - 0.99\angle -54.33^\circ = 9.95\angle 35.67^\circ V$$

$$I_L = \frac{V}{j\omega L} = \frac{9.95\angle 35.67^\circ}{10\angle 90^\circ} = 1.00\angle 54.33^\circ A$$

$$I_C = V(j\omega C) = [9.95\angle 35.67^\circ]10^{-3}\angle 90^\circ = 9.95\angle 125.67^\circ mA$$

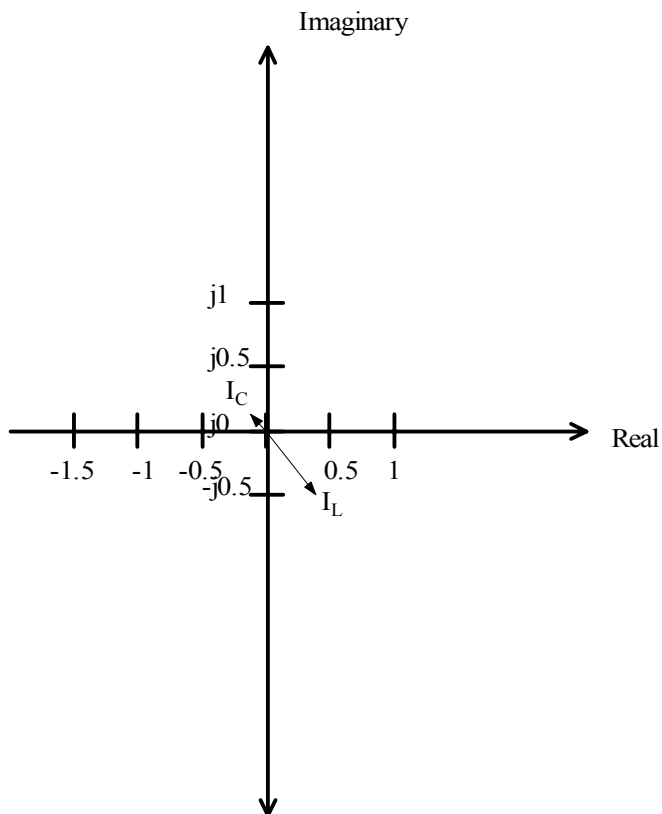

Problem 7.27

In the currents shown determine the frequency at which $i(t)$ is in phase with $v_s(t)$.

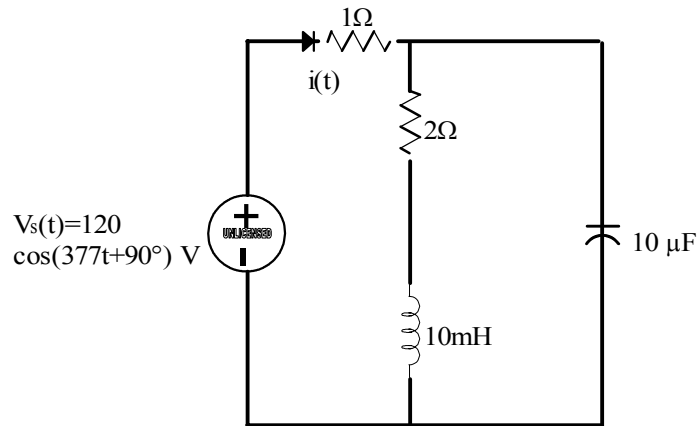

Suggested Solution

$$Z = (2 + j\omega L) \parallel \frac{1}{j\omega C} = \frac{\frac{L}{C} - \frac{j2}{\omega C}}{2 + j\left(\omega L - \frac{1}{\omega C}\right)} = \frac{K_1 \tan^{-1}\left(\frac{-2}{\frac{\omega C}{L}}\right)}{K_1 \tan^{-1}\left(\frac{\omega L - \frac{1}{\omega C}}{2}\right)}$$

For Z to be real

$$\frac{-2}{\omega C} = \frac{\omega L - \frac{1}{\omega C}}{2}$$

$$-4 = (\omega L)^2 - \frac{L}{C} \Rightarrow \omega = \frac{\sqrt{\frac{L}{C} - 4}}{L} = 3156$$

$$f = \frac{\omega}{2\pi} = 502.3 \text{ Hz}$$

Problem 7.28

Find the frequency domain voltage V_0 as shown.

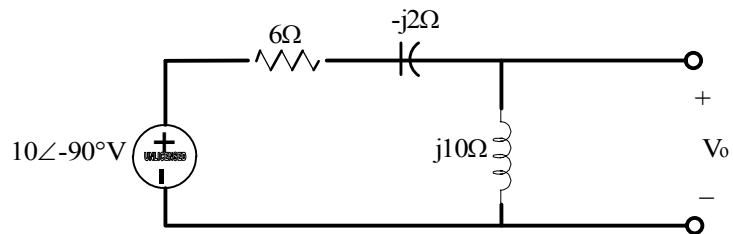

Suggested Solution

$$V_0 = 10\angle -90^\circ \frac{10j}{6 - 3j + 10j} = \frac{(10\angle -90^\circ)(10\angle 90^\circ)}{10\angle 53^\circ} = 10\angle -53.1^\circ\text{V}$$

Problem 7.29

Find the frequency domain voltage V_0 as shown.

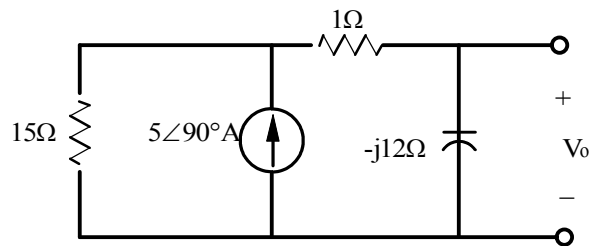

Suggested Solution

$$I_0 = 5\angle 30^\circ \frac{15}{15 + 1 - 12j} = 3.75\angle 66.9^\circ A$$

$$V_0 = -j12(3.75\angle 66.9^\circ) = 45\angle -23.1^\circ V$$

Problem 7.30

Find the frequency domain current I_0 as shown.

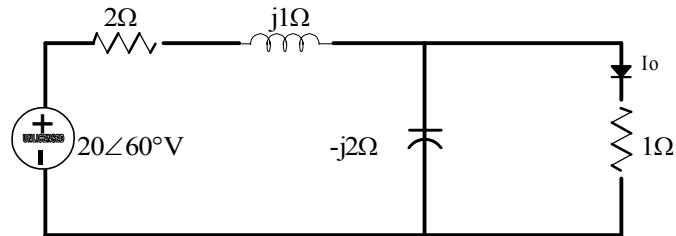

Suggested Solution

$$V = 20\angle 60^\circ \left\{ \frac{Z}{Z + 2 + j1} \right\}$$

$$Z = 1 \parallel -j2 = \frac{-j2}{1 - j2} = \frac{2\angle -90^\circ}{\sqrt{5}\angle -64.43^\circ} = 0.89\angle -26.57^\circ \Omega$$

$$V_0 = 20\angle 60^\circ \left[\frac{0.89\angle -26.57^\circ}{0.89\angle -26.57^\circ + 2 + j1} \right] = 20\angle 60^\circ (0.31\angle -38.66^\circ) = 6.20\angle 21.34^\circ V$$

$$I_0 = \frac{V}{R} = 6.20\angle 21.34^\circ A$$

Problem 7.31

Find the frequency domain voltage V_0 as shown.

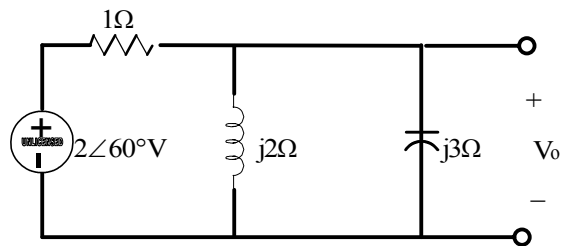

Suggested Solution

$$Z = \frac{j}{2} \parallel \frac{-j}{3} = \frac{\frac{1}{6}}{\frac{j}{2} - \frac{j}{3}} = -j$$

$$V_0 = 2\angle 60^\circ \frac{-j}{1-j} = \frac{2\angle -30^\circ}{\sqrt{2}\angle -45^\circ} = \sqrt{2}\angle 15^\circ\text{V}$$

Problem 7.32

Draw the frequency domain network and calculate $v_0(t)$ in the circuit shown if $i_s(t) = 100\cos(5000t + 8.13^\circ)\text{mA}$. Also, using a phasor diagram, show that $i_L(t) + i_R(t) = i_s(t)$.

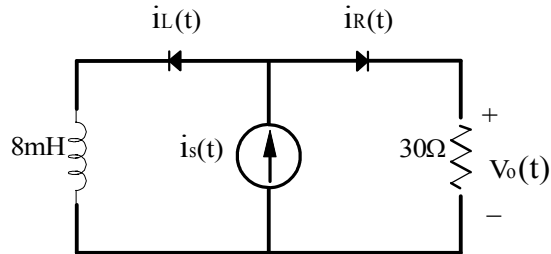

Suggested Solution

$$i_s(t) = 100\angle 8.13^\circ$$

$$j\omega L = j0.008(5000) = 40j$$

$$V_0(t) = i_s(t)(30 \parallel 40j) = 100\angle 8.13^\circ \left(\frac{30 - 40j}{30 + 40j} \right) = 2.4\angle 45^\circ$$

$$V_0(t) = 2.4 \cos(5000t + 45^\circ)\text{V}$$

$$i_L = \frac{V_0(t)}{40j} = 60\angle -45^\circ \text{mA}$$

$$i_R = \frac{V_0(t)}{30} = 80\angle 45^\circ \text{mA}$$

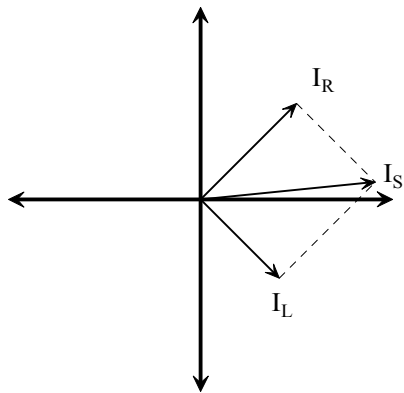

Problem 7.33

Draw the frequency domain network and calculate $v_0(t)$ in the circuit shown if $i_s(t) = 100\cos(5000t + 8.13^\circ)\text{mA}$. Also, using a phasor diagram, show that $i_1(t) + i_2(t) = i_s(t)$.

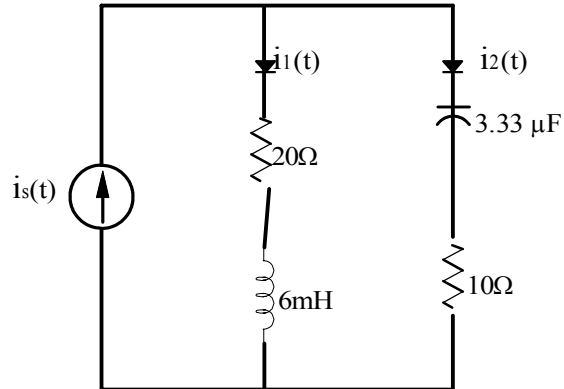

Suggested Solution

$$i_s(t) = 0.3 \angle -135^\circ \text{A}$$

$$j\omega L = j0.006(10000) = 60j$$

$$V_0(t) = i_s(t)((20 + 60j) \parallel (10 - 30j)) = 14.14 \angle 180^\circ$$

$$V_0(t) = 14.14 \cos(10000t - 45^\circ) \text{V}$$

$$i_1 = \frac{V_0(t)}{20 + 60j} = .224 \angle 251.6^\circ \text{mA}$$

$$i_2 = \frac{V_0(t)}{10 - 30j} = .447 \angle -108.4^\circ \text{mA}$$

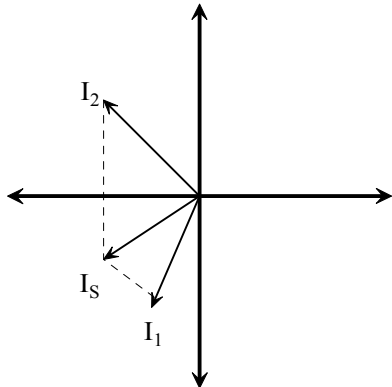

Problem 7.34

Find I_0 in the network shown.

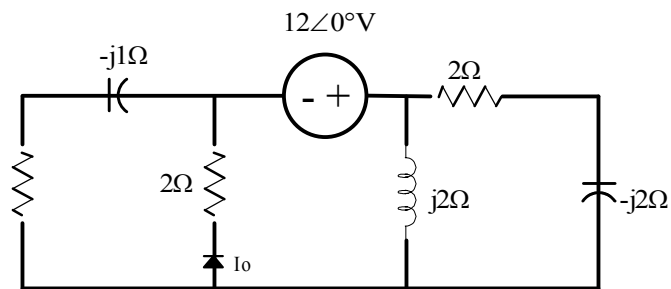

Suggested Solution

$$Z = 2j \parallel (2 - 2j) + 2 \parallel (1 - j) = 2 + 2j + 0.8 - 0.4j = 2.8 + j1.6 = 3.22\angle 30^\circ$$

$$I_s = \frac{12\angle 0^\circ}{3.22\angle 30^\circ} = 3.73\angle -30^\circ$$

$$I_0 = 3.73\angle -30^\circ \left(\frac{1 - j}{.8 - .4j} \right) = 5.89\angle -48.4^\circ A$$

Problem 7.35

Find I_0 in the network shown.

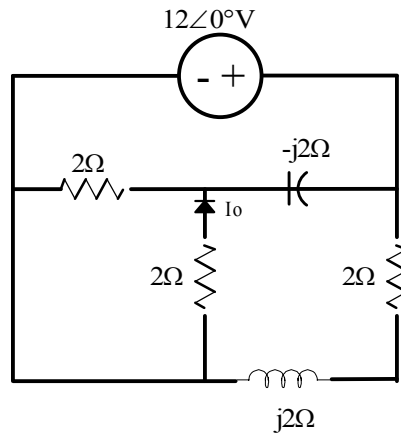

Suggested Solution

$$I_0 = \frac{1}{2} \left(\frac{12\angle 0^\circ}{1-2j} \right) = -2.68\angle 63.4^\circ A$$

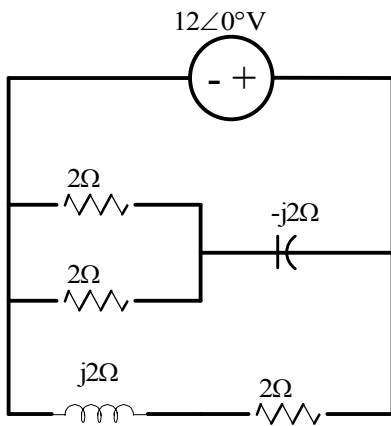

Problem 7.36

In the circuit shown, if $V_0 = 4\angle 45^\circ$ V, find I_1

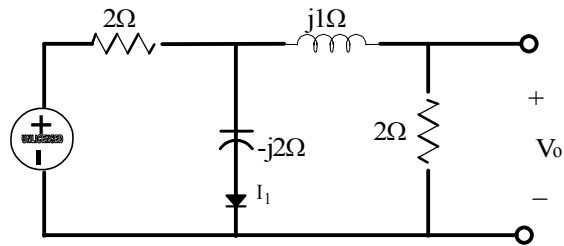

Suggested Solution

$$I_2 = \frac{4\angle 45^\circ}{2} = 2\angle 45^\circ A$$

$$V_1 = I_2(2 + j) = 4.47\angle 71.6^\circ$$

$$I_1 = \frac{V_1}{-j2} = \frac{4.47\angle 71.6^\circ}{2\angle -90^\circ} = 2.24\angle 162^\circ A$$

Problem 7.37

Find V_s in the network shown if $V_0 = 4\angle 0^\circ$ V.

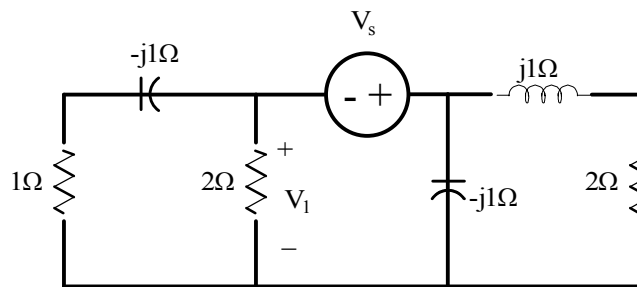

Suggested Solution

$$Z_1 = \frac{2(1-j)}{3-j} = 0.8 - j0.4$$

$$Z_2 = \frac{(-j)(2+j)}{2} = 0.5 - j1$$

$$I = \frac{4\angle 0^\circ}{0.8 - j0.4}$$

$$V_2 = IZ_2 = 5\angle -36.86^\circ \text{ V}$$

$$V_s = -(4\angle 0^\circ + 5\angle -36.86^\circ) = -8 + j3 = 8.54\angle -20.56^\circ \text{ V}$$

Problem 7.38

Find V_s in the network shown if $I_0 = 2 \angle 0^\circ$ A.

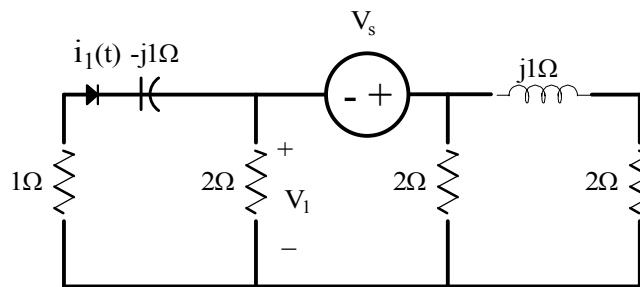

Suggested Solution

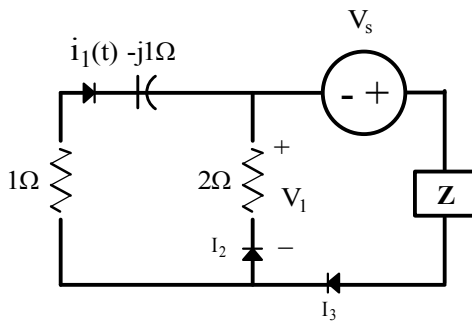

$$Z = \frac{2(2+j)}{4+j}$$

$$V_1 = I_1(1-j) = 2 - j2$$

$$I_2 = \frac{V_1}{2} = 1 - j$$

$$I_3 = I_1 + I_2 = 2 + 1 - j = 3 - j$$

$$V_2 = I_3 Z = (3-j) \left(\frac{4+2j}{4+j} \right) = \frac{14+j2}{4+j}$$

$$V_s = V_1 + V_2 = 2 - 2j + \frac{14+j2}{4+j} = 5.58 \angle -14^\circ V$$

Problem 7.39

Find V_s in the network shown if $I_0 = 2\angle 0^\circ$ A.

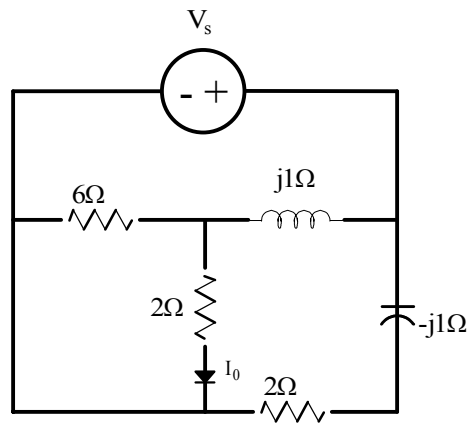

Suggested Solution

$$I_0 = 2\angle 0^\circ$$

$$I_1 = 3\angle 0^\circ$$

$$V_s = (3\angle 0^\circ)(2 + j) = 6 + 3j$$

Problem 7.40

Find I_s in the network shown if $V_0 = 2\angle 0^\circ$ V.

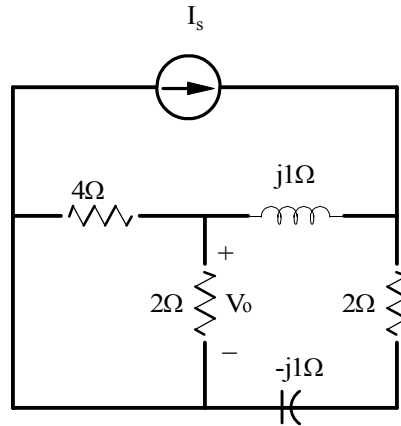

Suggested Solution

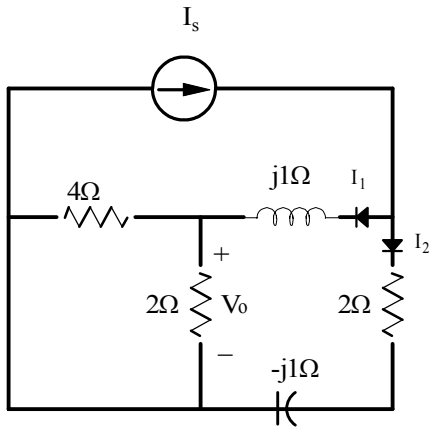

$$V_1 = 8\angle 0^\circ \text{ V}$$

$$I_1 = \frac{8}{4/3} = 6 \text{ A}$$

$$I_2 = \frac{V_s}{2-j} = \frac{10\angle 37^\circ}{2.24\angle -26.6^\circ} = 4.46\angle 63.6^\circ$$

$$I_s = I_1 + I_2 = 6 + 1.98 + 4j = 8 + 4j$$

Problem 7.41

Find I_0 in the network shown if $V_1 = 2\angle 0^\circ$ V.

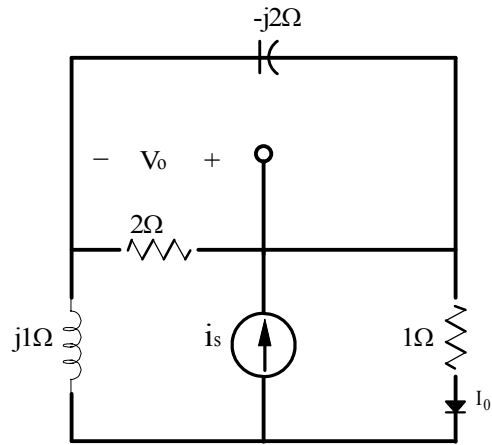

Suggested Solution

$$V_1 = V_0 - 4 = 4\angle 0^\circ \text{ V}$$

$$I_s = \frac{V_0}{1} + \frac{4}{2} + \frac{4}{-2j}$$

$$I_1 = 2 + 2j = I_s - V_0$$

$$V_0 = j(2 + 2j) = 2j - 2$$

$$V_0 = V_0 + V_1 = 2j - 2 + 4 = 2 + 2j$$

$$I_0 = V_0 = 2 + 2j = 2.828\angle 45^\circ$$

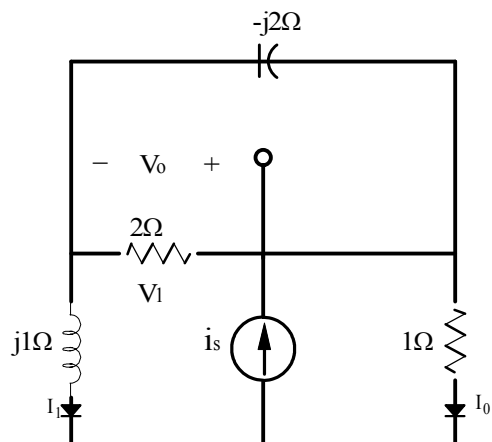

Problem 7.42

In the network shown $V_0 = 4\angle 45^\circ$ V: find Z .

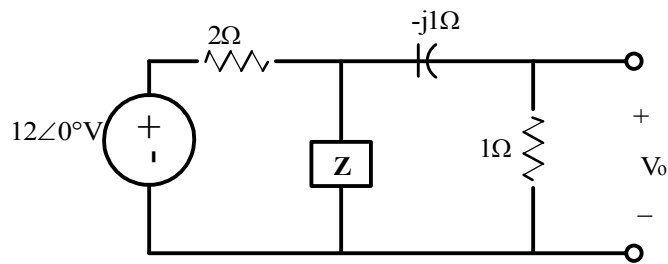

Suggested Solution

$$V_1 = 4\angle 45^\circ(1 - j) = 5.66\angle 0^\circ V$$

$$\text{THEN, } \frac{12 - V_1}{2} = \frac{V_1}{Z} + 4\angle 45^\circ$$

$$\text{SO, } \frac{12 - 5.66}{2} = \frac{5.66}{Z} + 2.83 + j2.83$$

$$Z = \frac{5.66}{2.85\angle -83^\circ} = 2\angle 83^\circ$$

Problem 7.43

In the network shown $V_0 = 2\angle 45^\circ$ V: find Z .

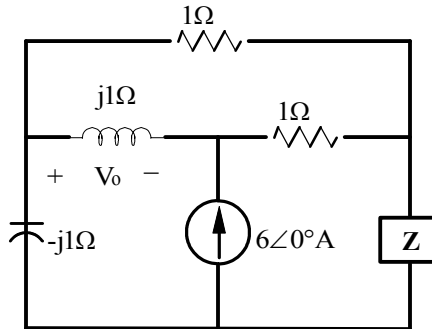

Suggested Solution

$$I_1 = \frac{2\angle 45^\circ}{j} = 1.414 - j1.414$$

$$I_2 = 6 + I_1 = 7.414 - j1.414$$

$$V_2 = 1I_2 = 7.414 - j1.414$$

$$V_3 = V_1 + V_2 = 8.83$$

$$I_3 = \frac{V_3}{1} = 8.83$$

$$I_4 = I_1 + I_3 = 10.242 - j1.414$$

$$V_4 = -jI_4 = -1.414 - j10.242$$

$$V_4 + V_3 + V_0 = 0$$

$$V_0 = -(V_4 + V_3) = -(-1.414 - j10.242 + 8.83) = -7.416 + j10.242$$

$$I_0 = I_2 + I_3 = 7.414 - j1.414 + 8.83 = 16.25 - j1.414$$

$$Z = \frac{V_0}{I_0} = \frac{-7.416 + j10.242}{16.25 - j1.414} = 0.78\angle 130.87^\circ \Omega$$

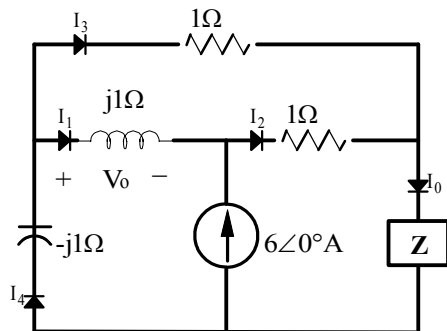

Problem 7.44

Find I_0 in the network shown if $I_s = 12 \angle 0^\circ$ A.

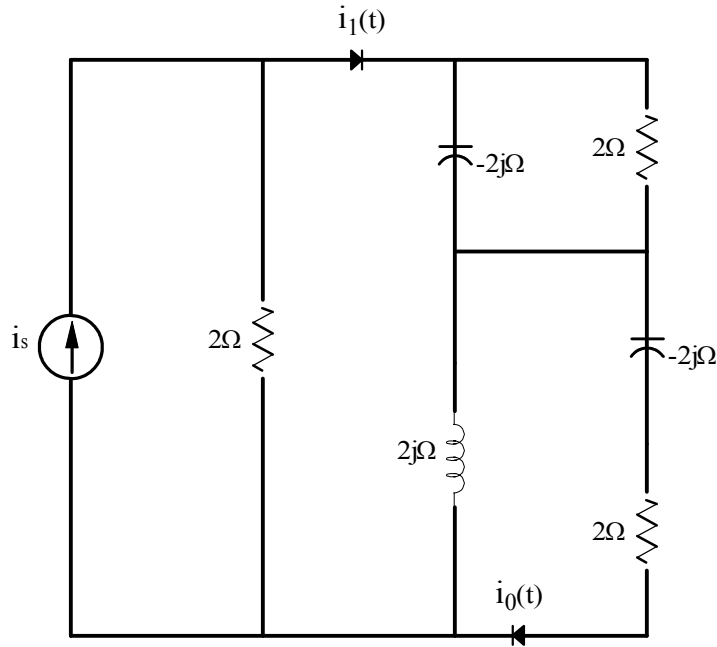

Suggested Solution

$$I_1 = I_s \left[\frac{2}{2+Z} \right]$$

$$I_0 = I_1 \left[\frac{j2}{2-j2+j2} \right] = I_1 (1 \angle 90^\circ)$$

$$Z = (j2 \parallel (2-j2)) + (2 \parallel -j2) = \frac{j4+4}{2} - \frac{j4}{2-j2} = 2+j2 - \frac{j2}{1-j} = \frac{4-j2}{1-j}$$

$$I_1 = 12 \angle 0^\circ \left[\frac{2}{2 + \frac{4-j2}{1-j}} \right] = \frac{24(1-j)}{6-j4} = \frac{12(1-j)}{3-j2} = 4.69 \angle -11.31^\circ \text{ A}$$

$$I_0 = (4.69 \angle -11.31^\circ) (1 \angle 90^\circ) = 4.69 \angle 78.69^\circ \text{ A}$$

Problem 7.45

Use nodal analysis to find I_0 in the circuit shown.

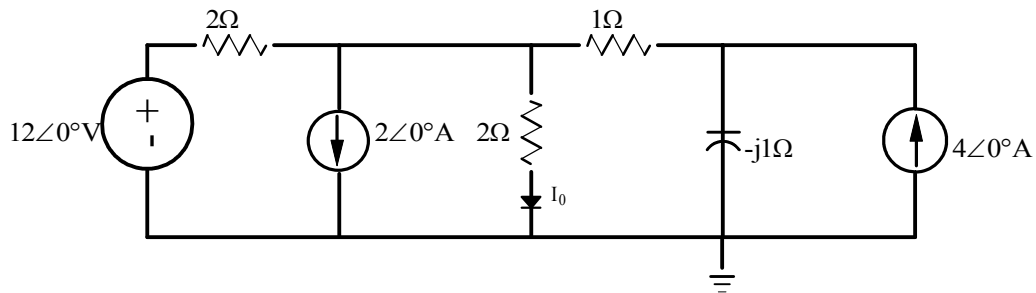

Suggested Solution

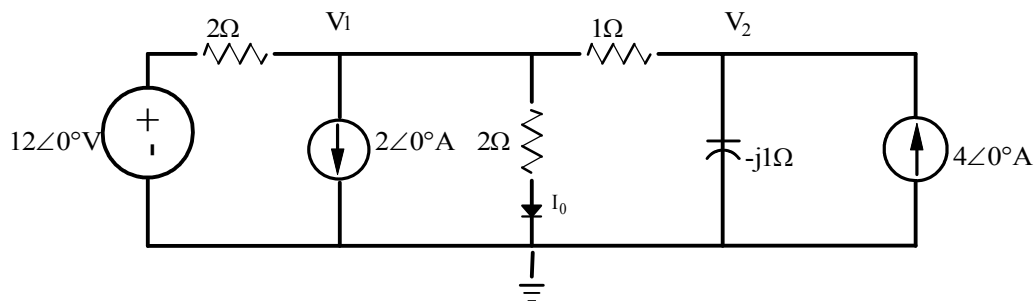

$$V_1: \frac{12 - V_1}{2} = 2 + \frac{V_1 - V_2}{1} + \frac{V_1}{2}$$

$$8 = 4V_1 - 2V_2$$

$$V_2: \frac{V_1 - V_2}{1} + 4 = \frac{V_2}{-j1}$$

$$V_2 = \frac{4 + V_1}{1 + j1}$$

$$8 = 4V_1 - \frac{2(4 + V_1)}{1 + j1}$$

$$V_1 = \frac{4(2 + j)}{1 + j2}$$

$$I_0 = \frac{V_1}{2} = \frac{2(2 + j)}{1 + j2} = 2 \angle -36.87^\circ$$

Problem 7.46

Use nodal analysis to find V_0 in the circuit shown.

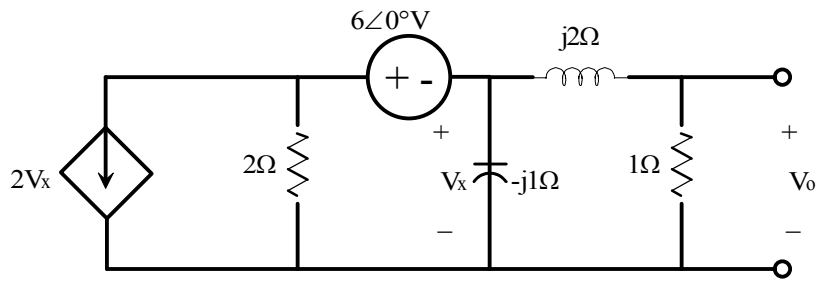

Suggested Solution

$$2V_x + \frac{V_x + 6}{2} + \frac{V_x}{-2} + \frac{V_x}{1 + 2j} = 0$$

$$V_x = \frac{-2(1 + 2j)}{1 + 4j} V$$

$$V_0 = V_x \left(\frac{1}{1 + 2j} \right) = -.49 \angle -76^\circ$$

Problem 7.47

Find V_0 in the network shown using nodal analysis.

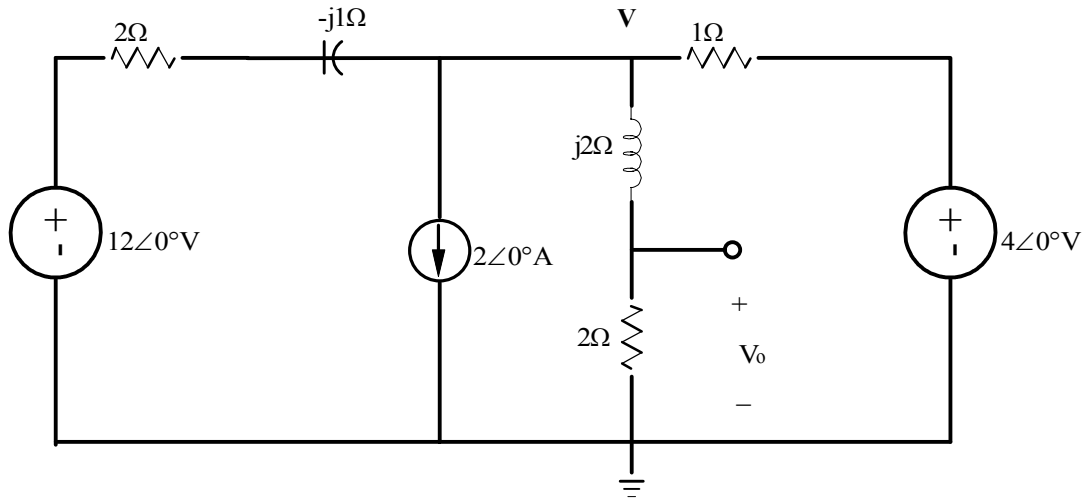

Suggested Solution

$$V_0 = V \left[\frac{2}{2 + j2} \right] = \frac{V}{\sqrt{2} \angle 45^\circ} = \frac{V}{1 + j1}$$

$$\frac{12 - V}{2 - j1} = 2 + \frac{V}{2 + j2} + \frac{V - 4}{1} = V \left[1 + \frac{1}{2 + j2} \right] - 2 = V \left[\frac{3 + j2}{2 + j2} \right] - 2$$

$$12 - V = V \left[\frac{(3 + j2)(2 - j1)}{2 + j2} \right] - 4 + j2 = V \left[\frac{8 + j1}{2 + j2} \right] - 4 + j2$$

$$16 - j2 = V \left[1 + \frac{8 + j1}{2 + j2} \right] = V \left[\frac{2 + j2 + 8 + j1}{2 + j2} \right]$$

$$16 - j2 = V \left[\frac{10 + j3}{2 + j2} \right]$$

$$V = \frac{4(8 - j1)(1 + j1)}{(10 + j3)}$$

$$V_0 = \frac{V}{1 + j1} = \frac{4(8 - j1)}{10 + j3} = \frac{32.25 \angle -7.13^\circ}{10.44 \angle 16.70^\circ}$$

$$V_0 = 3.09 \angle -23.83^\circ \text{ V}$$

Problem 7.48

Use nodal analysis to determine I_0 in the network shown.
In addition, solve the problem using MATLAB.

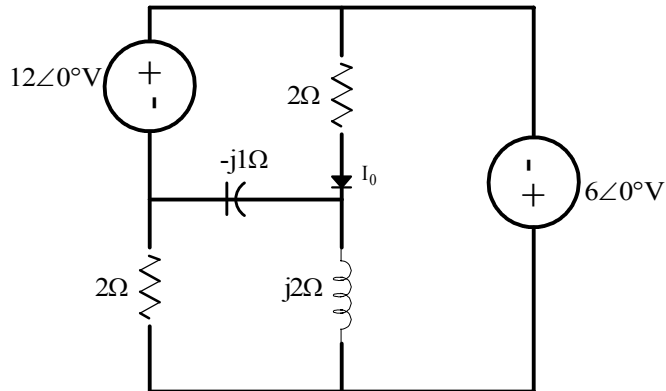

Suggested Solution

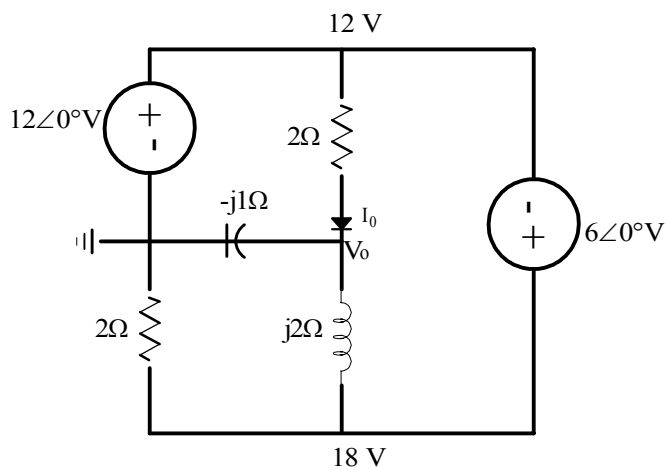

$$V_0; \frac{12 - V_0}{2} + \frac{18 - V_0}{j2} = \frac{V_0}{-j1} = jV_0$$

$$12 - V_0 - j18 + jV_0 = j2V_0$$

$$V_0(1 + j1) = 12 - j18$$

$$V_0 = \frac{12 - j18}{1 + j1}$$

$$I_0 = \frac{12 - V_0}{2} = \frac{12 - \frac{12 - j18}{1 + j1}}{2} = \frac{12 + j12 - 12 + j18}{2(1 + j1)} = \frac{j15}{1 + j1} = 10.64 \angle 45^\circ A$$

MATLAB SOLUTION

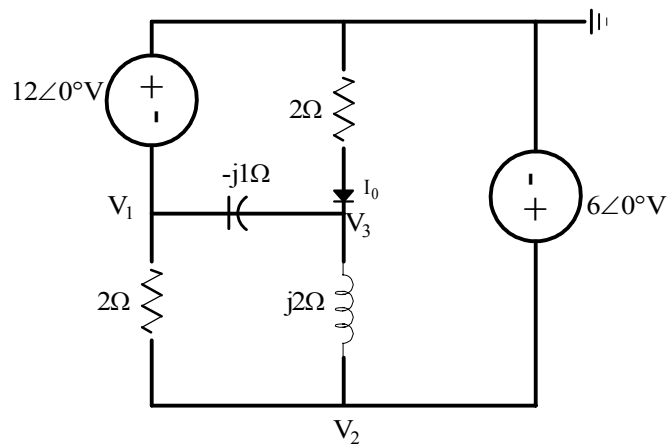

$$V_1 = -12\angle 0^\circ \quad V_2 = 6\angle 0^\circ$$

$$\frac{V_3}{2} + \frac{V_3 - V_1}{-j1} + \frac{V_3 - V_2}{j2} = 0$$

$$\begin{bmatrix} 1 & 0 & 0 \\ 0 & 1 & 0 \\ 2 & -1 & -1+j1 \end{bmatrix} \begin{bmatrix} V_1 \\ V_2 \\ V_3 \end{bmatrix} = \begin{bmatrix} -12 \\ 6 \\ 0 \end{bmatrix}$$

```
>>g=[2 -1 -1+1j;1 0 0;0 1 0]
```

```
>>i=[0;-12;6]
```

```
>>v=inv(g)*I
```

v=

```
-12.0000
 6.0000
-15.0000 -15.0000i
```

Since $V_3 = -15 - j15$

Then $I_0 = -V_3/2 = 7.5 + j7.5 \text{ A} = 10.61 / \underline{45^\circ} \text{ A}$

Problem 7.49

Find V_0 in the network shown.

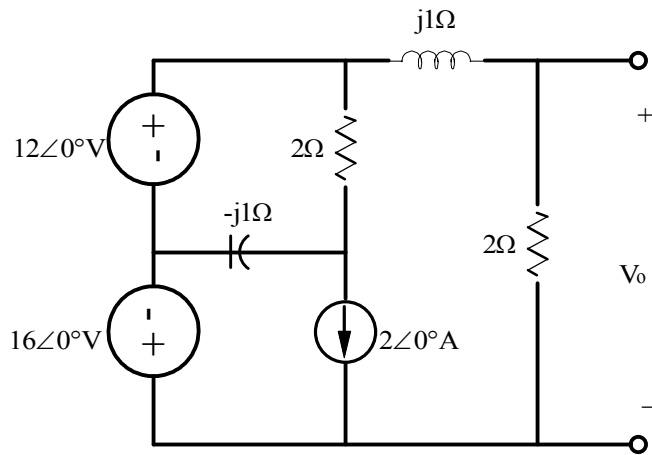

Suggested Solution

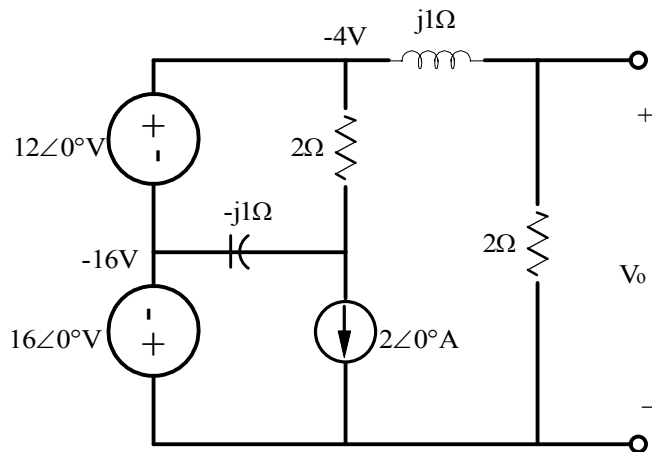

$$V_0 = -4 \left[\frac{2}{2 + j1} \right]$$

$$V_0 = 3.58 \angle 153.43^\circ \text{ V}$$

Problem 7.50

Find the voltage across the indicator in the circuit shown using nodal analysis.

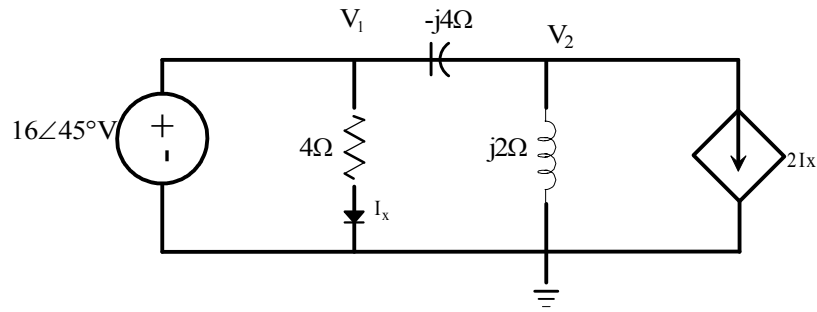

Suggested Solution

$$KCL @ V_2; \quad \frac{V_1 - V_2}{-j4} = \frac{V_2}{2} + I_x$$

$$I_x = \frac{V_1}{4}; \quad V_1 = 16\angle 45^\circ$$

$$V_1 - V_2 = -2V_2 - \frac{j8V_1}{4}$$

$$V_1(1 + j2) = -V_2$$

$$V_2 = -V_1(1 + j2) = (16\angle -135^\circ)(1 + j2)$$

$$V_2 = 35.78\angle -71.57^\circ V$$

Problem 7.51

Use mesh analysis to find V_0 in the circuit shown.

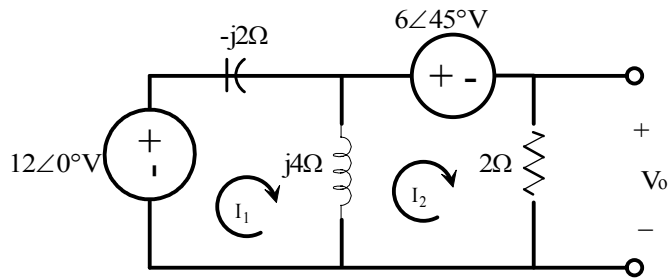

Suggested Solution

$$V_0 = 2I_2$$

mesh equations

$$12 = I_1(j2) + I_2(-j4)$$

$$-6\angle 45^\circ = -j4I_1 + I_2(2 + j4)$$

matrix form

$$\begin{bmatrix} j2 & -j4 \\ -j4 & 2 + j4 \end{bmatrix} \begin{bmatrix} I_1 \\ I_2 \end{bmatrix} = \begin{bmatrix} 12 \\ 6\angle -135^\circ \end{bmatrix}$$

Solve for I_2

$$I_2 = \frac{\begin{bmatrix} j2 & 12 \\ -j4 & 6\angle 135^\circ \end{bmatrix}}{\begin{bmatrix} j2 & -j4 \\ -j4 & 2 + j4 \end{bmatrix}} = \frac{12\angle -45^\circ + 48\angle 90^\circ}{j4 - 8 + 16} = 4.52\angle 51.3^\circ A$$

$$V_0 = 2I_2 = 9.04\angle 51.3^\circ V$$

Problem 7.52

Use mesh analysis to find V_0 in the circuit shown.

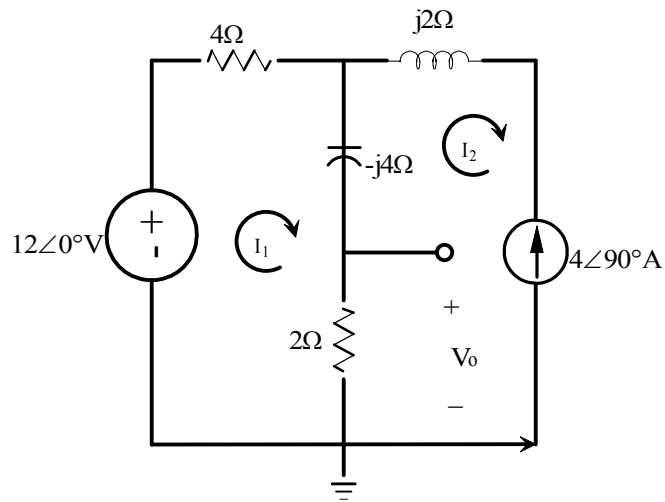

Suggested Solution

mesh equations

$$12 = I_1(4 - j4 + 2) - I_2(2 - j4) \quad (1)$$

$$I_2 = -4\angle 90^\circ = -j4A \quad (2)$$

Substitute (2) into (1)

$$12 = I_1(6 - j4) + j4(2 - j4)$$

$$I_1(6 - j4) = 12 - j8 - 16 = -4 - j8$$

$$I_1 = \frac{2(-1 - j2)}{(3 - j2)}$$

$$I_1 = 1.24\angle -82.87^\circ A = (0.15 - j1.23)A$$

$$V_0 = (I_1 - I_2)2 = (0.15 - j1.23 + j4)2$$

$$V_0 = 5.55\angle -86.9^\circ V$$

Problem 7.53

Using loop analysis, find I_0 in the network shown.

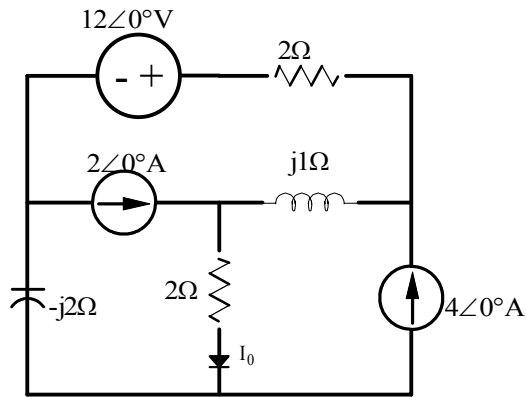

Suggested Solution

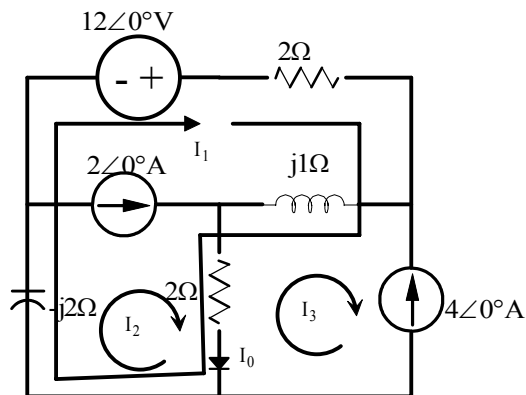

$$I_3 = -4A \quad I_2 = 2A$$

Supermesh Equations

$$12 = I_1(2 + j1 + 2 - j2) - j1I_3 - 2I_3 + 2I_2 - j2I_2$$

$$12 = I_1(4 - j1) - I_3(2 + j1) + I_2(2 - j2)$$

$$12 = I_1(4 - j1) + 8 + j4 + 4 - j4$$

$$I_1 = 0$$

$$I_0 = I_1 + I_2 - I_3 = 0 + 2 - (-4) = 6A$$

MATLAB SOLUTION

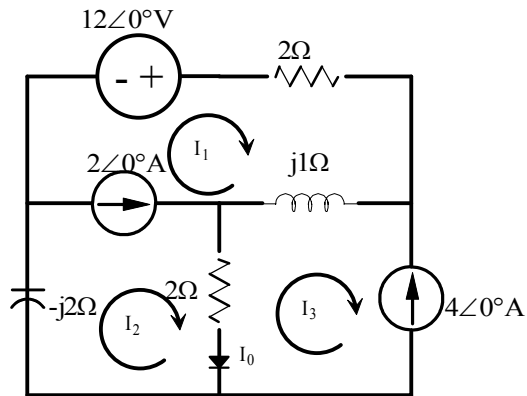

$$I_2 = -4\angle 0^\circ I_1 - I_3 = 2\angle 0^\circ$$

$$12\angle 0^\circ = 2I_3 + j1(I_3 - I_2) + 2(I_1 - I_2) - j2I_1$$

$$\begin{bmatrix} 0 & 1 & 0 \\ 1 & 0 & -1 \\ 2 - j2 & -2 - j1 & 2 + j1 \end{bmatrix} \begin{bmatrix} I_1 \\ I_2 \\ I_3 \end{bmatrix} = \begin{bmatrix} -4 \\ 2 \\ 12 \end{bmatrix}$$

```
>> z=[2-2j -2-1j 2+1j; 0 1 0; 1 0 -1]
```

```
>> v=[12;-4;2]
```

```
>> i=inv(z)*v
```

```
i =
```

```
    2.0000 + 0.0000i
```

```
   -4.0000
```

```
   -0.0000 + 0.0000i
```

$$I_0 = I_1 - I_2 = 2 - (-4) = 6\text{A}$$

Problem 7.54

Find V_0 in the network shown.

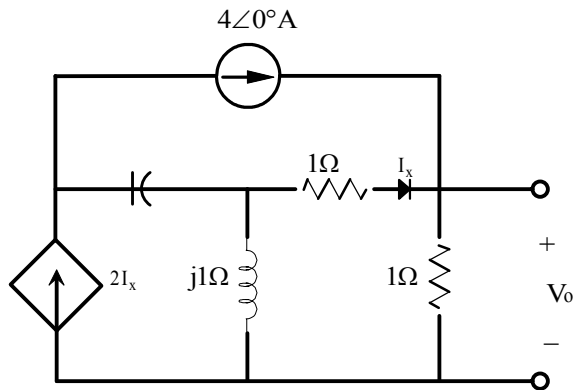

Suggested Solution

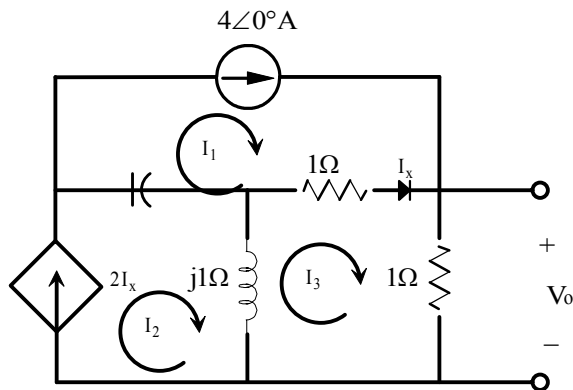

$$I_1 = 4, \quad I_2 = 2I_x, \quad I_x = I_3 - 4$$

$$j(I_3 - I_2) + 1(I_3 - I_1) + 1I_3 = 0$$

$$j(I_3 - 2I_x) + 1(I_3 - 4) + I_3 = 0$$

$$jI_3 - 2jI_x + I_3 - 4 + I_3 = 0$$

$$jI_3 - 2(I_3 + 4) + I_3 - 4 + I_3 = 0$$

$$jI_3 - 2jI_3 + 8j + I_3 - 4 + I_3 = 0$$

$$I_3(j - 2j + 1 + 1) = 4 - 8j$$

$$I_3 = \frac{4 - 8j}{2 - j} = 4 \angle -36.86^\circ \text{ A}$$

Problem 7.55

Find V_0 in the network shown.

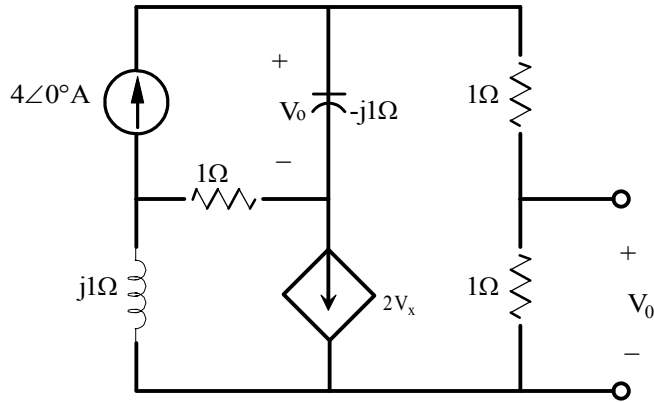

Suggested Solution

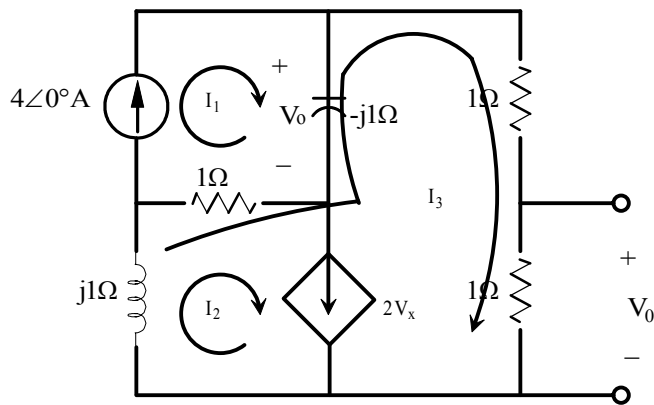

$$I_1 = 4\angle 0^\circ \quad I_2 = 2V_x$$

$$V_x = -j(I_1 - I_3)$$

For I_3 ,

$$j(I_2 - I_3) + 1(I_2 + I_3 - 4) - j(I_3 - 2V_x) + 2I_3 = 0$$

$$\text{Solving } I_3 = \frac{4 + 12j}{5}$$

$$V_0 = .8 + 2.4j$$

Problem 7.56

Use superposition to find V_0 in the network shown.

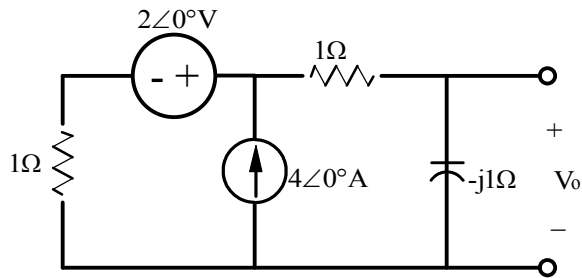

Suggested Solution

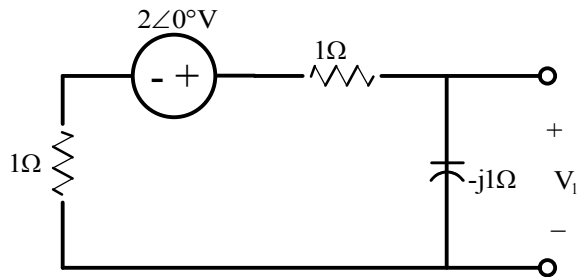

$$V_1 = -2 \left(\frac{-j}{2-j} \right) = \frac{2j}{2-j} = \frac{2\angle 90^\circ}{2.236\angle -26.56^\circ} = 0.89\angle 116.56^\circ V$$

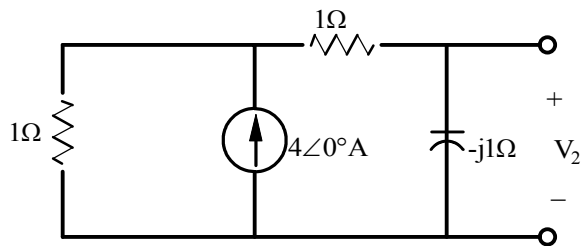

$$V_2 = \frac{4(1)}{2-j} (-j) = \frac{-4j}{2-j} = \frac{-4\angle 90^\circ}{2.236\angle -26.56^\circ} = 1.78\angle -63.4^\circ V$$

$$V_0 = V_1 + V_2 = -0.398 + j0.396 + 0.797 - j1.59 = 0.399 - j1.194 = 0.89\angle -63.6^\circ V$$

Problem 7.57

Find V_0 in the network shown using superposition.

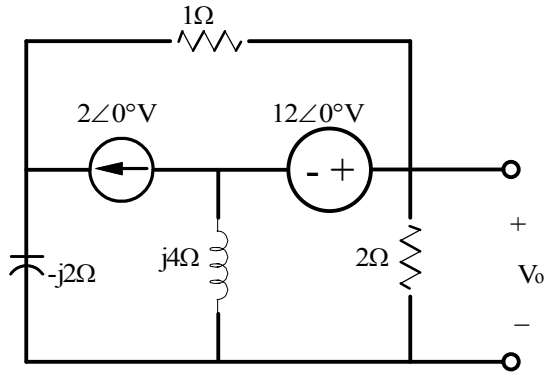

Suggested Solution

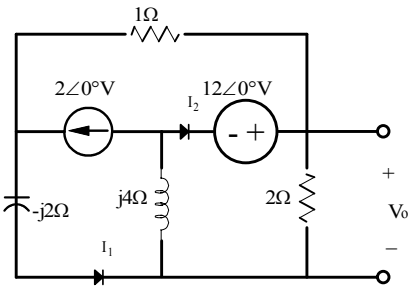

For the 2A source,

$$I_1 = \frac{2 + 2}{2 - 2j + \frac{8j}{2 + 4j}} = \frac{4(2 + 4j)}{12 + 12j}$$

$$V_0 = I_1 \left(\frac{8j}{2 + 4j} \right) = \frac{-32j}{12 + 12j}$$

For the 12V source,

$$I_2 = \frac{12}{4j + \frac{2(2 - 2j)}{2 + 2 - 2j}} = \frac{12(4 - 2j)}{12 + 12j}$$

$$V_0 = I_2 \frac{2(2 - 2j)}{2 + 2 - 2j} = \frac{12(4 - 4j)}{12 + 12j}$$

Summing

$$V_0 = \frac{-32j + 48 - 48j}{12 + 12j} = 5.5 \angle -104^\circ \text{V}$$

Problem 7.58

Using superposition, find V_0 in the circuit shown.

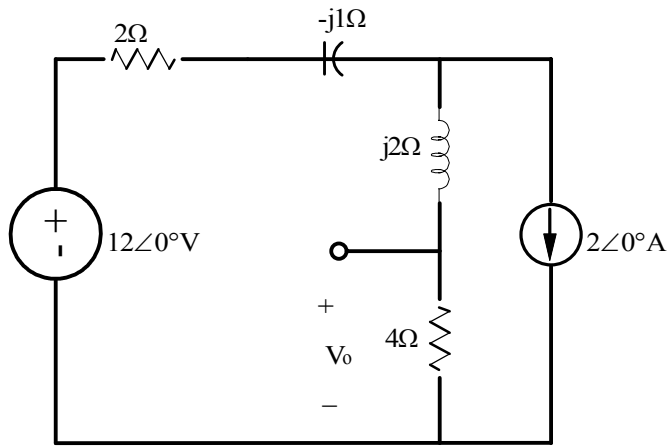

Suggested Solution

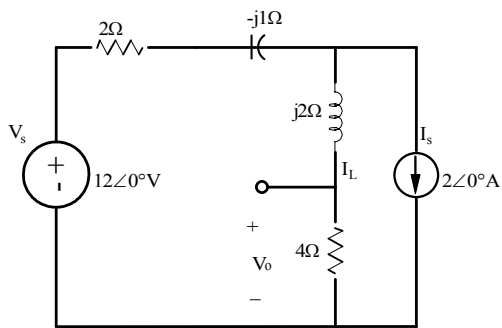

For the voltage source

$$V_1 = \frac{4}{4 + 2 + j2 - j1} (12\angle 0^\circ) = \frac{48}{6 + j1}$$

For the current source

$$I_L = I_s \left[\frac{2 - j1}{4 + 2 + j2 - j1} \right] = \frac{-4 + j2}{6 + j1}$$

$$V_2 = 4I_L = \frac{-16 + j8}{6 + j1}$$

Summing

$$V_0 = V_1 + V_2 = \frac{32 + j8}{6 + j1} = 5.41\angle 4.57^\circ V$$

Problem 7.59

Use both superposition and MATLAB to determine V_0 in the circuit shown.

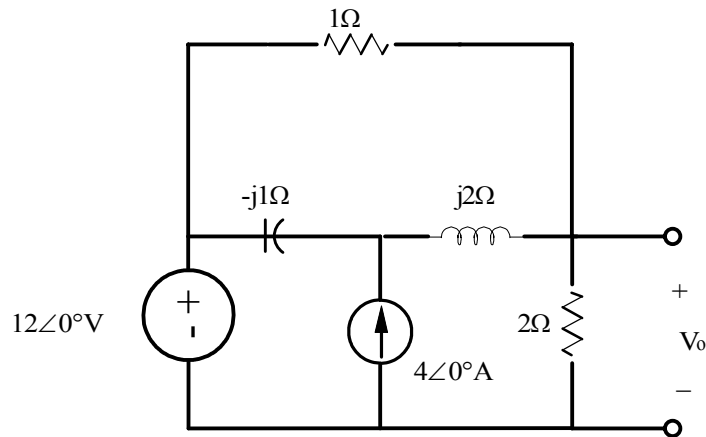

Suggested Solution

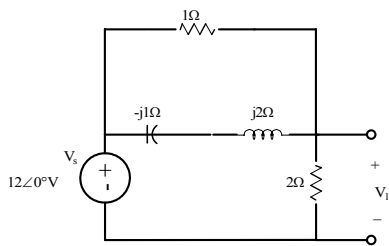

$$V_1 = V_0 \left[\frac{2}{2 + \frac{1}{2} + j\frac{1}{2}} \right] = 12 \left(\frac{2}{\frac{5}{2} + j\frac{1}{2}} \right) = \frac{48}{5 + j1} = 9.23 - j1.85V$$

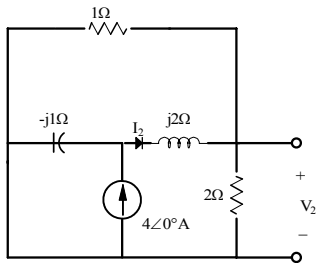

$$I_2 = 4 \left[\frac{-j1}{-j1 + j2 + \frac{2}{3}} \right] = \frac{-j4}{j1 + \frac{2}{3}} = \frac{-j12}{2 + j3}$$

$$V_2 = \frac{2}{3}(I_2) = \frac{-j8}{2 + j3} = -1.85 - j1.23V$$

$$V_0 = V_1 + V_2 = 7.38 - j3.08 = 8.00 \angle -22.65^\circ V$$

MATLAB SOLUTION

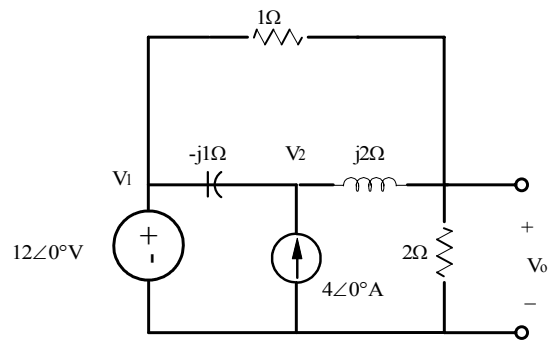

$$V_1 = 12\angle 0^\circ V$$

$$\frac{V_1 - V_2}{-j1} + 4 + \frac{V_0 - V_2}{j2} = 0$$

$$\frac{V_1 - V_0}{1} + \frac{V_2 - V_0}{j2} - \frac{V_0}{2} = 0$$

$$\begin{bmatrix} 1 & 0 & 0 \\ -2 & 1 & 1 \\ j2 & 1 & -1-j3 \end{bmatrix} \begin{bmatrix} V_1 \\ V_2 \\ V_3 \end{bmatrix} = \begin{bmatrix} 12 \\ -j8 \\ 0 \end{bmatrix}$$

```
>> g=[0+2j 1 -1-3j;1 0 0;-2 1 1]
```

```
>> i=[0;12;-8j]
```

```
>> v=inv(g)*i
```

v =

```
12.0000 - 0.0000i
16.6154 - 4.9231i
7.3846 - 3.0769i
```

$$V_0 = 7.3846 - j3.0769 = 8.00 / -22.62^\circ \text{ V}$$

Problem 7.60

Use source exchange to determine V_0 in the network shown.

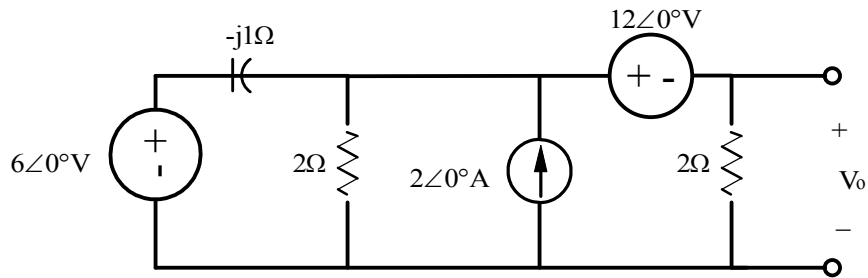

Suggested Solution

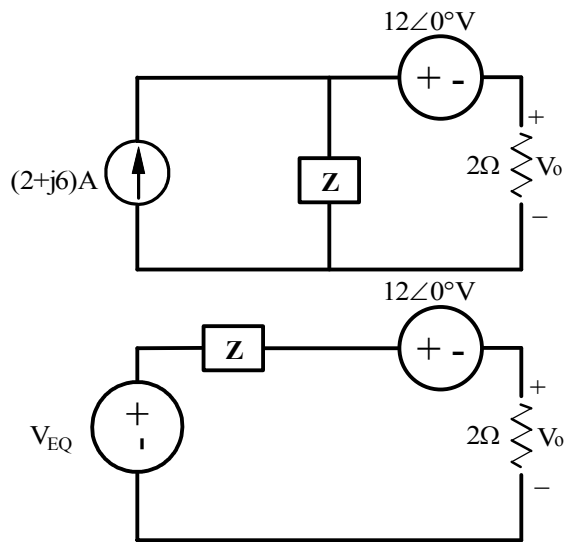

$$Z = 2 \parallel -j = \frac{-j2}{2-j1} = \frac{2}{1+j2}$$

$$V_{EQ} = (2+j6)(Z_{EQ}) = \frac{2(2+j6)}{1+j2} = 5.66\angle 8.13^\circ V = (5.60 + j0.80)V$$

$$V_0 = (V_{EQ} - 12) \left[\frac{2}{2+Z_{EQ}} \right] = (-6.4 + j0.8) \left[\frac{4}{3+j2} \right] = 7.16\angle 139.18^\circ V$$

Problem 7.61

Use source exchange to find the current I_0 in the network shown.

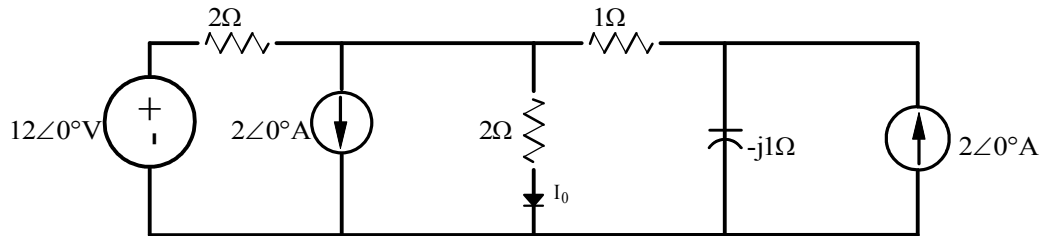

Suggested Solution

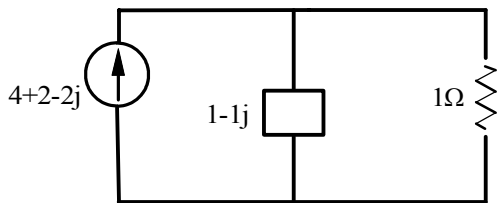
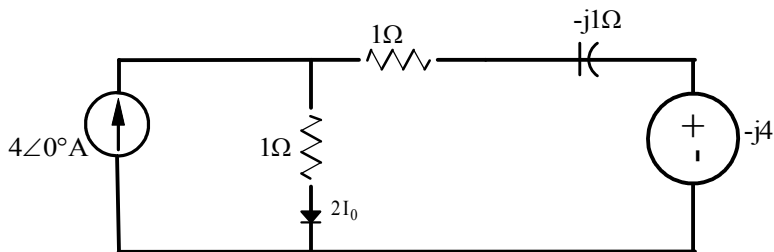
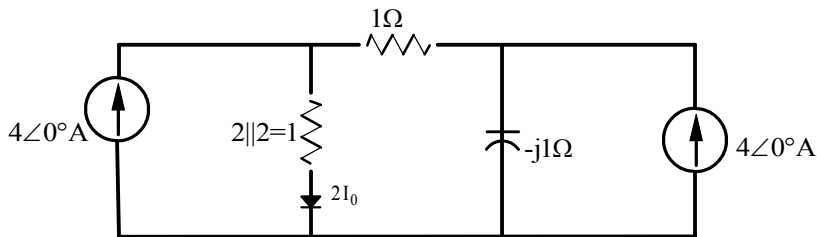

$$2I_0 = (6 - 2j) \frac{1 - j}{2 - j}$$

$$I_0 = 2 \angle -37^\circ$$

Problem 7.62

Use source transformation to determine I_0 in the circuit shown.

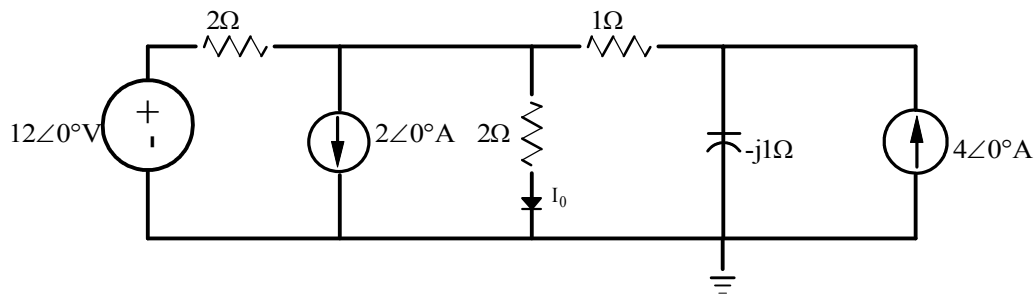

Suggested Solution

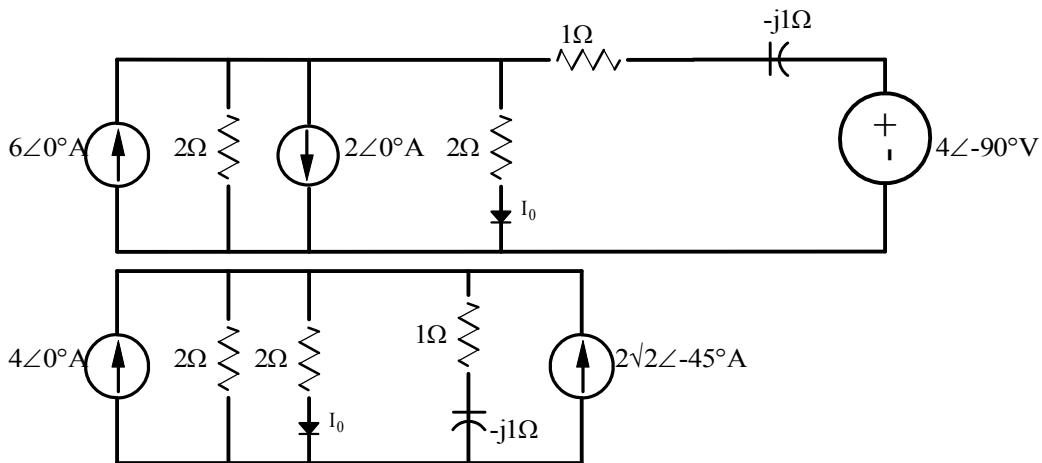

$$Z_{EQ} = 2 \parallel (1 - j1) = \frac{2 - j2}{3 - j1} \quad I_{EQ} = 4 + 2\sqrt{2} \angle -45^\circ = 6 - j2$$

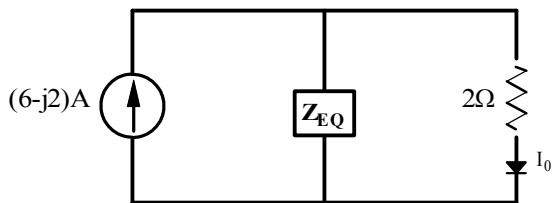

$$I_0 = (6 - j2) \left[\frac{Z_{EQ}}{Z_{EQ} + 2} \right] = (6 - j2) \left[\frac{2 - j2}{2 - j2 + 6 - j2} \right] = \frac{(6 - j2)(2 - j2)}{8 - j4}$$

$$I_0 = \frac{(3 - j1)(1 - j1)}{2 - j1} = 2 \angle -36.87^\circ \text{ A}$$

Problem 7.63

Use Thevenin's theorem to find V_0 in the circuit shown.

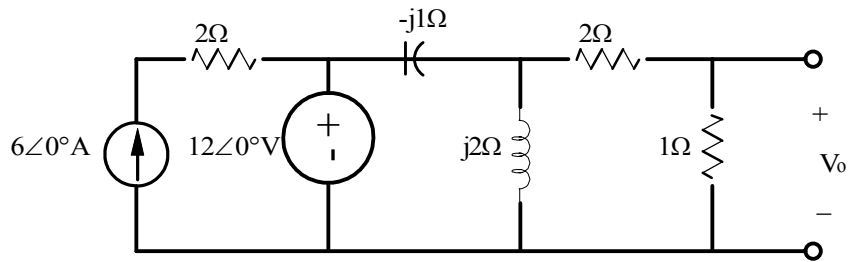

Suggested Solution

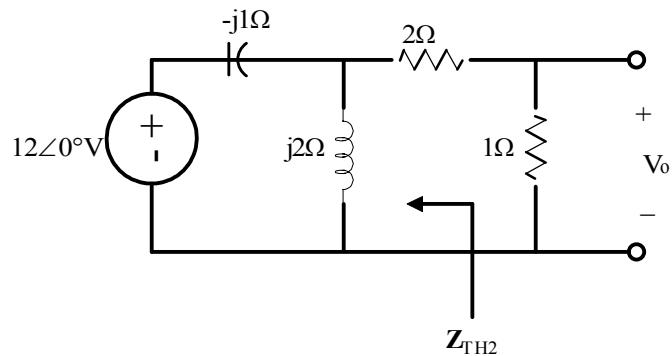
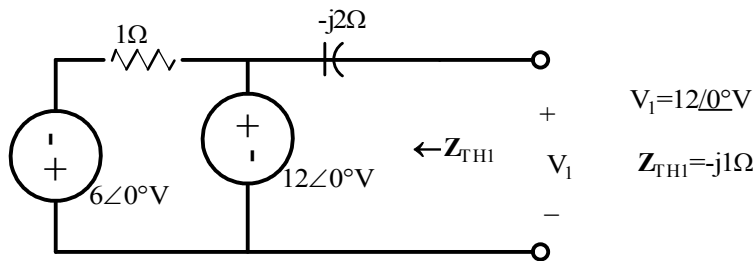
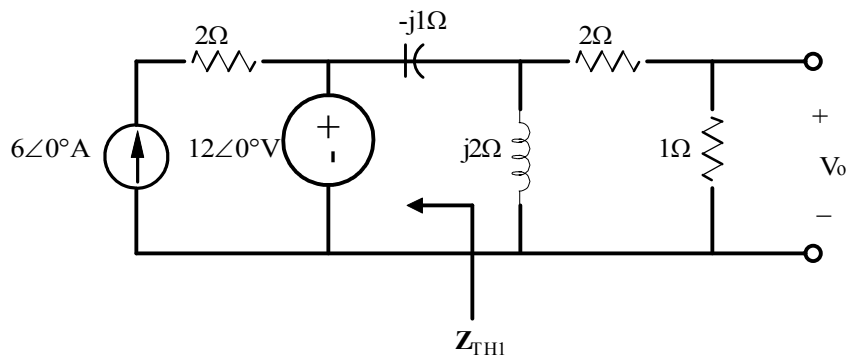

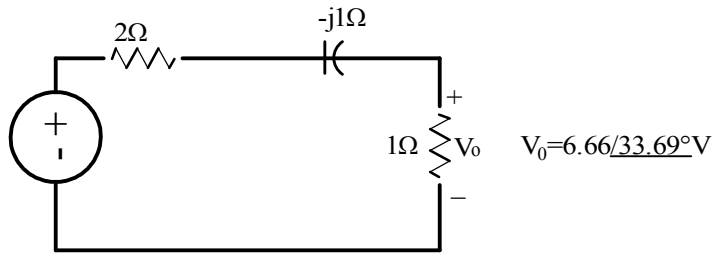
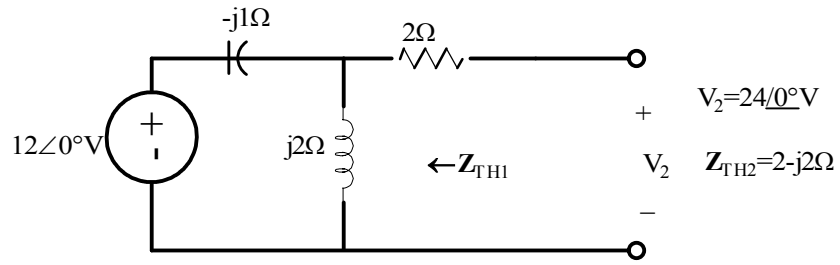

Problem 7.64

Using Thevenin's theorem, find V_0 in the network shown.

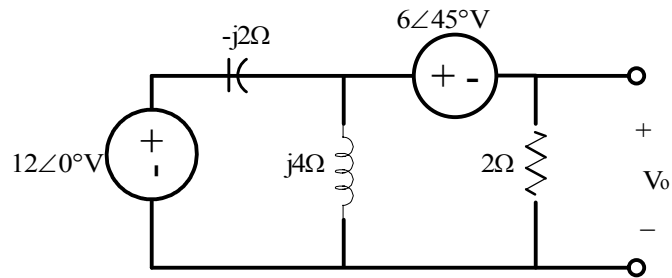

Suggested Solution

$$V_{oc} = \frac{12(j4)}{j2} - 6\angle 45^\circ = 20.2\angle -12.1^\circ V$$

$$R_{TH} = \frac{(-j2)(j4)}{j2} = -j4\Omega$$

$$V_0 = \frac{(20.2\angle -12.1^\circ)2}{2 - j4} = 9.03\angle 51.3^\circ V$$

Problem 7.65

Use Thevenin's theorem to find V_0 in the circuit shown.

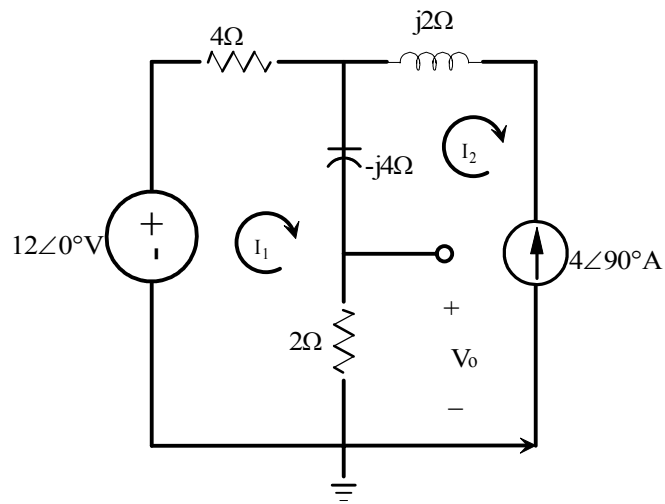

Suggested Solution

$$V_{oc} = 12 + 4(4\angle 90^\circ) = 12 + j16V$$

$$R_{TH} = 4 - j4\Omega$$

$$V_0 = \frac{(12 + j16)2}{2 + 4 - j4} = 5.55\angle 86.8^\circ V$$

Problem 7.66

Solve Problem 7.49 using Thevenin's theorem.

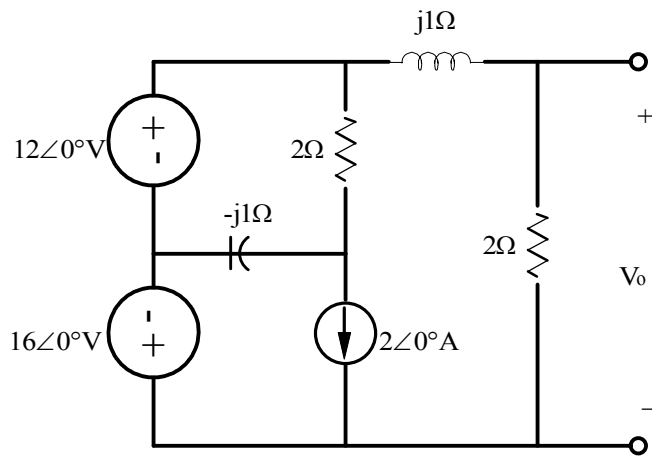

Suggested Solution

$$V_{TH} = 12\angle 0^\circ - 16\angle 0^\circ = 4\angle 180^\circ V$$

$$Z_{TH} = 0\Omega$$

$$V_0 = 4\angle 180^\circ \left[\frac{2}{2 + j1} \right] = 3.58\angle 153.43^\circ V$$

Problem 7.67

Apply Thevenin's theorem twice to find V_0 in the circuit shown.

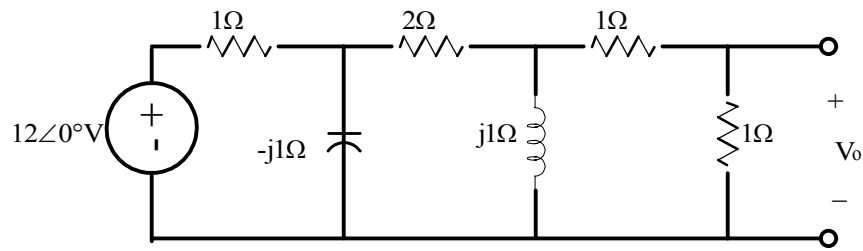

Suggested Solution

PART I

$$V_{oc} = \frac{12 - j}{1 - j} = \frac{-12j}{1 - j}$$

$$Z_{TH} = \frac{-j}{1 - j} \Omega$$

PART II

$$V_{oc} = \frac{\frac{-12}{1 - j}}{\frac{-j}{1 - j} + 2 + j} = (-j) = \frac{12}{3 - 2j}$$

$$Z_{TH} = \frac{j \left(2 + \frac{-j}{1 - j} \right)}{j + 2 + \frac{-j}{1 - j}} = \frac{3 + 2j}{3 - 2j} \Omega$$

FINALLY

$$V_0 = \frac{12}{2 + \frac{3 - 2j}{3 + 2j}} (1) = 1.3 \angle 12.5^\circ \text{V}$$

Problem 7.68

Find V_0 in the network shown using Thevenin's theorem.

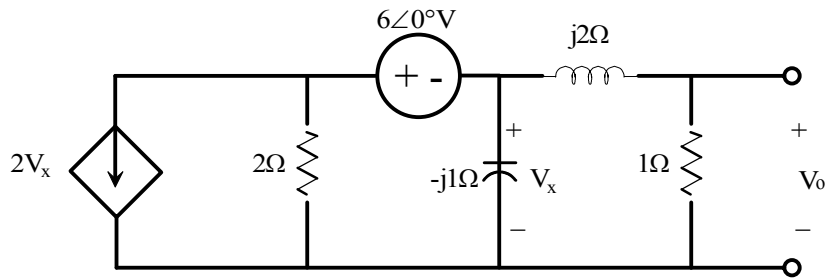

Suggested Solution

$$V_{OC} = V_x$$

$$2V_x + \frac{V_{OC} + 6}{2} + \frac{V_{OC}}{-j1} = 0 \Rightarrow V_{OC} = \frac{-6}{5 + j2}$$

$$I_{SC} = \frac{-6}{2} = -3A$$

$$Z_{TH} = \frac{V_{OC}}{I_{SC}} = \frac{2}{5 + 2j} \Omega$$

$$V_0 = V_{OC} \left[\frac{1}{1 + j2 + Z_{TH}} \right] = \left(\frac{-6}{5 + j2} \right) \left(\frac{5 + j2}{(1 + j2)(5 + j2) + 2} \right) = \frac{-6(5 + j2)}{3 + j12} = 2.61 \angle 125.8^\circ V$$

Problem 7.69

Find the Thevenin equivalent for the network shown at the terminals A-B.

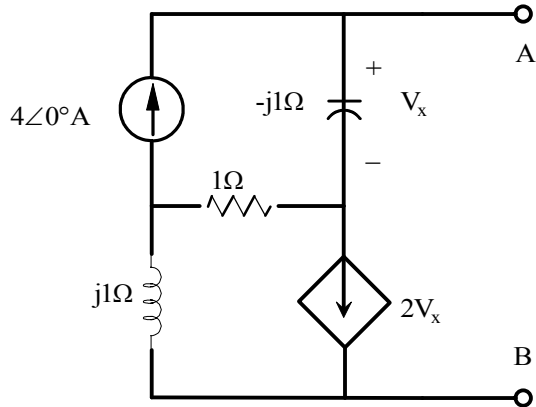

Suggested Solution

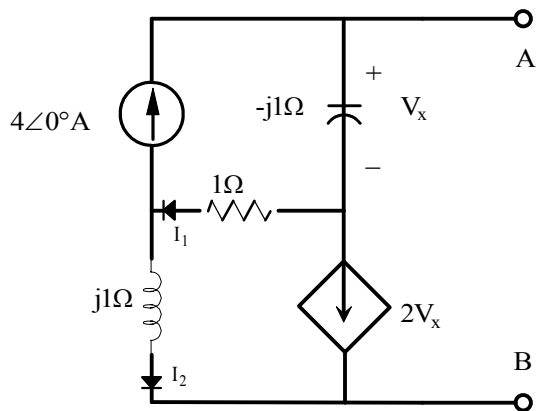

For V_{OC}

$$V_x = 4\angle 0^\circ (-j) = -4j$$

$$2V_x = -8j$$

$$I_1 = 4 + 8j \quad I_2 = 4 + 8j - 4 = 8j$$

$$V_1 = 8j - j = 7j$$

$$V_{OC} = -8 + (4 + 8j) - 4j = -4 + 4j$$

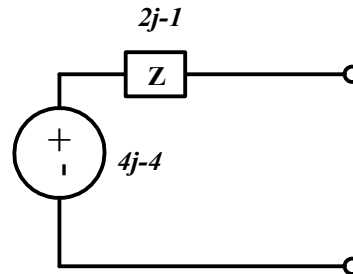

For I_{SC}

$$j(I_{SC} + 2V_x) + 1(I_{SC} + 2V_x - 4) - j(I_{SC} - 4) = 0$$

$$V_x = -j(4 - I_{SC}) \text{ YIELDS } I_{SC} = 2.4 + .8j$$

$$Z_{TH} = \frac{-4 + 4j}{2.4 + .8j} = -1 + 2j$$

Problem 7.70

Find V_x in the circuit shown using Norton's theorem.

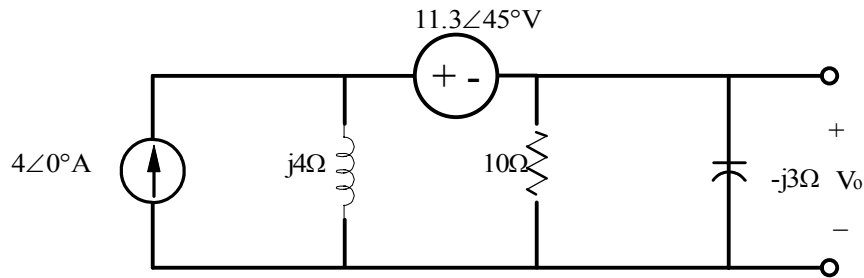

Suggested Solution

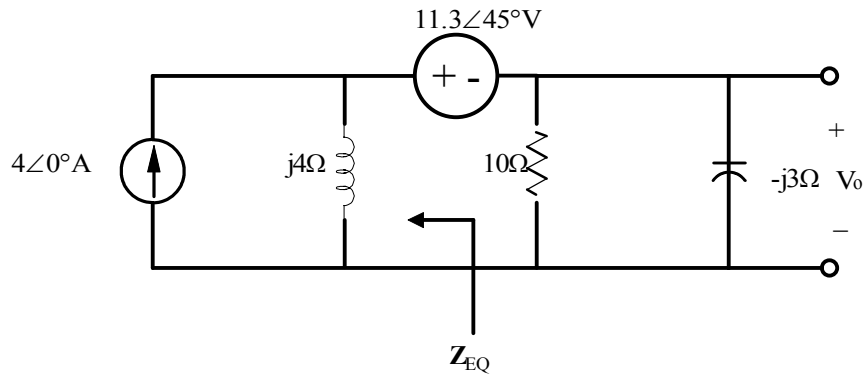

$$Z_{EQ} = j4\Omega$$

$$4 = \frac{V}{j4} + I_{SC} \quad \text{where } V = 11.3\angle 45^\circ V$$

$$I_{SC} = 4 + \frac{jV}{4} = 6 + j2 \text{ A}$$

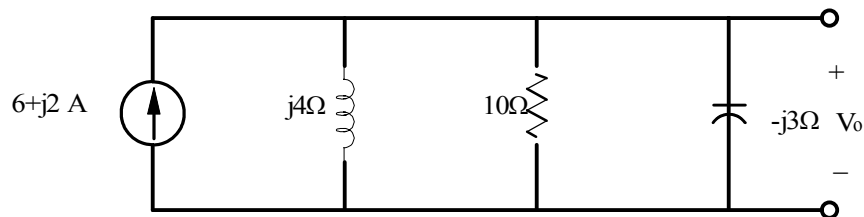

$$V_x = I_{SC} [10 \parallel j4 \parallel -j3] = I_{SC} \left[\frac{1}{\frac{1}{10} + \frac{1}{j4} + \frac{1}{-j3}} \right] = \frac{I_{SC}}{0.10 + j0.08} = 48.59 \angle -21.37^\circ V$$

Problem 7.71

Find I_0 in the network shown using Norton's theorem.

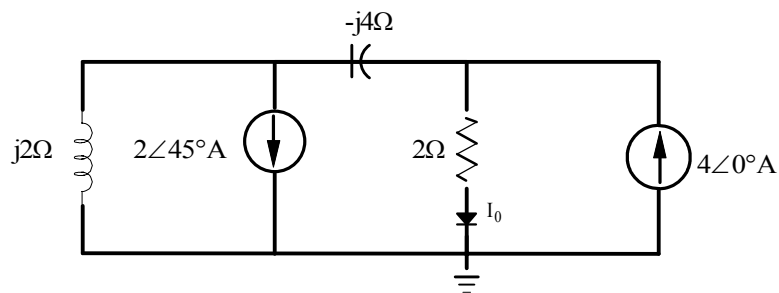

Suggested Solution

$$I_{SC} = -2\angle 45^\circ \frac{2j}{2j - 4j} + 4\angle 0^\circ = 4 + 2\angle 45^\circ$$

$$Z_{TH} = -4j + 2j = -2j$$

$$I_0 = I_{SC} \frac{Z_{TH}}{2 + Z_{TH}} = (5.41 + 1.41j) \frac{-2j}{2 - 2j} = 4\angle -30.3^\circ A$$

Problem 7.72

Apply both Norton's theorem and MATLAB to find V_0 in the network shown.

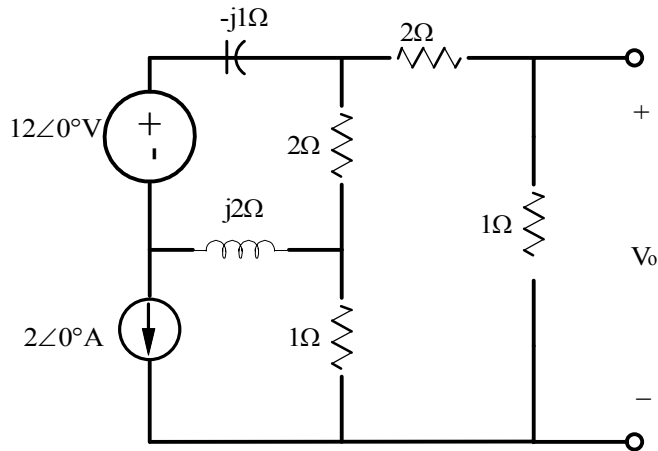

Suggested Solution

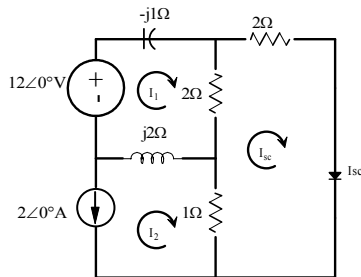

mesh equations

$$12 = I_1(2 + j1) - 2I_{sc} - j2I_2 \quad (1)$$

$$-2 = I_2 \quad (2)$$

$$0 = I_{sc}(3) - 2I_1 - I_2 \quad (3)$$

substitute (2) into (1) & (3)

$$I_1(2 + j1) - 2I_{sc} = 12 - j4 \quad (4)$$

$$I_1 = 1 + \frac{3}{2}I_{sc} \quad (5)$$

substitute (5) into (4)

$$(2 + j1)\left(1 + \frac{3}{2}I_{sc}\right) - 2I_{sc} = 12 - j4 \Rightarrow I_{sc}\left(1 + j\frac{3}{2}\right) = 10 - j5$$

$$I_{sc} = \frac{10(2 - j1)}{2 + j3}$$

$$Z_{EQ} = 2 \parallel (j2 - j1) + 1 = 1 + \frac{j2}{2 + j1} = \frac{2 + j3}{2 + j1}$$

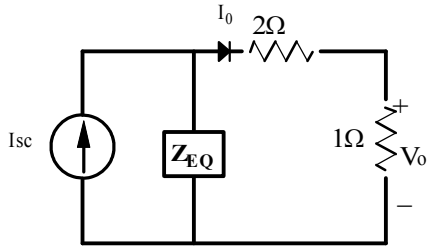

$$I_0 = I_{sc} \left[\frac{Z_{EQ}}{3 + Z_{EQ}} \right] = \left(\frac{10(2 - j1)}{2 + j3} \right) \left[\frac{2 + j3}{3(2 + j1) + 2 + j3} \right]$$

$$V_0 = 1I_0 = \frac{10(2 - j1)}{8 + j6} = \frac{5(2 - j1)}{4 + j3}$$

$$V_0 = 2.24 \angle -63.43^\circ \text{ V}$$

MATLAB SOLUTION

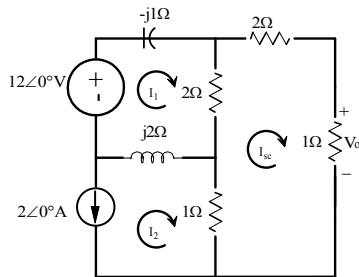

$$I_1 = 2 \angle 0^\circ \text{ A}$$

$$12 = -j1I_2 + (I_2 - I_3) + j2(I_2 - I_1)$$

$$0 = 2I_3 + (1)I_3 + (I_3 - I_2)(1) + 2(I_3 - I_2)$$

$$\begin{bmatrix} 1 & 0 & 0 \\ -j2 & 2 + j1 & -2 \\ -1 & -2 & 6 \end{bmatrix} \begin{bmatrix} I_1 \\ I_2 \\ I_3 \end{bmatrix} = \begin{bmatrix} -2 \\ 12 \\ 0 \end{bmatrix}$$

```
>> z=[1 0 0;-2j 2+1j -2;-1 -2 6];
```

```
>> v=[-2;12;0];
```

```
>> i=inv(z)*v
```

i =

```

-2.0000
 4.0000 - 6.0000i
 1.0000 - 2.0000i
```

$$V_0 = I_3(1) = 1 - j2 = 2.24 \angle -63.43^\circ \text{ V}$$

Problem 7.73

Find V_0 using Norton's theorem for the circuit shown.

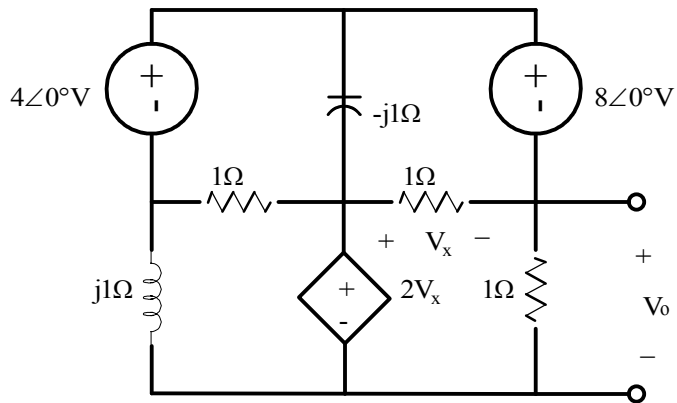

Suggested Solution

$$V_x = 2V_x - V_{oc}$$

$$V_{oc} = V_1 - 4$$

$$V_x = V_1 - 4$$

$$\frac{V_1}{j1} + \frac{V_1 - 2V_x}{1} + \frac{V_1 + 4 - 2V_x}{-j1} + \frac{V_1 - 4 - 2V_x}{1} = 0$$

$$V_1 = 6V \quad V_{oc} = 2V$$

$$V_x = 0$$

$$\frac{8}{-j1} + \frac{4}{1} + \frac{4}{j1} + I_{sc} = 0$$

$$I_{sc} = -4 - j4 \text{ A}$$

$$Z_{TH} = \frac{V_{oc}}{I_{sc}} = \frac{2}{-4 - j4} = -\frac{1}{4} + j\frac{1}{4} \Omega$$

$$I_0 = 2.53 \angle -18.43^\circ \text{ A}$$

$$V_0 = I_0(1) = 2.53 \angle -18.43^\circ \text{ V}$$

Problem 7.74

Use Norton's theorem to find V_0 in the network shown.

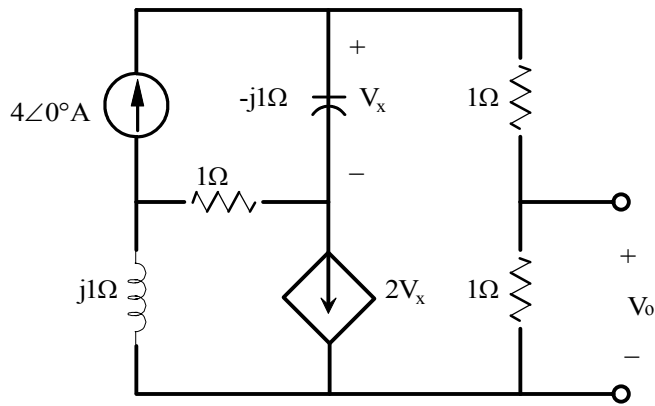

Suggested Solution

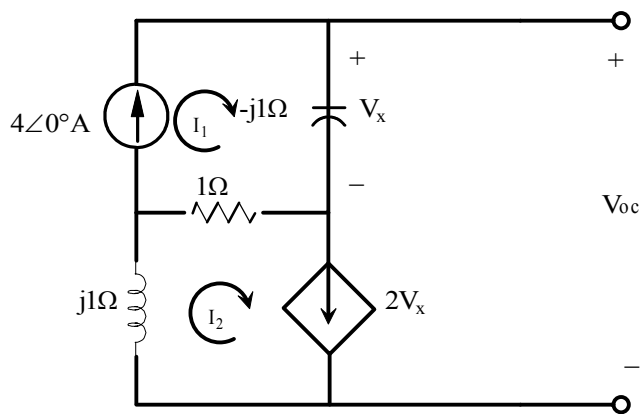

$$I_1 = 4\angle 0^\circ \quad I_2 = 2V_x$$

$$V_x = (-j1)I_1 = -j4V \quad I_2 = -j8A$$

$$I_2(1+j1) - I_1(1-j1) + V_{oc} = 0$$

$$V_{oc} = j8(1+j1) + 4(1-j1) = -4 + j4V$$

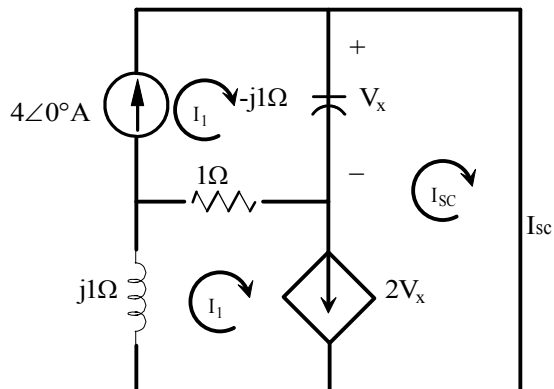

$$I_1 = 4\angle 0^\circ A$$

$$I_2 - I_{SC} = 2V_x \quad V_x = (-j1)(I_1 - I_{SC})$$

$$I_2(1 + j1) - I_1(1 - j1) + I_{SC}(-j1) = 0$$

$$[I_{SC}(1 + j2) - j8](1 + j1) - 4(1 - j1) + I_{SC}(-j1) = 0$$

$$I_{SC} = \frac{-4 + j4}{-1 + j2} A$$

$$I_0 = I_{SC} \left[\frac{Z_{TH}}{Z_{TH} + 2} \right]$$

$$Z_{TH} = -1 + j2$$

$$I_0 = \frac{-4 + j4}{1 + j2} A$$

$$V_0 = (1)I_0 = 2.53\angle 71.57^\circ V$$

Problem 7.75

Use MATLAB to find the node voltages in the network shown.

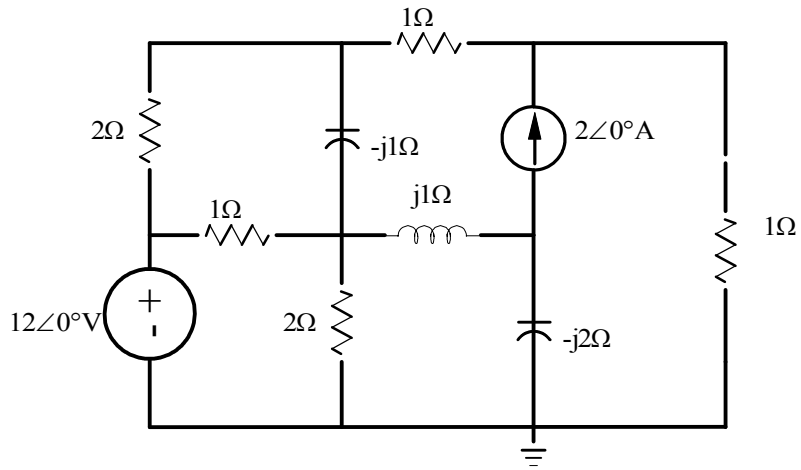

Suggested Solution

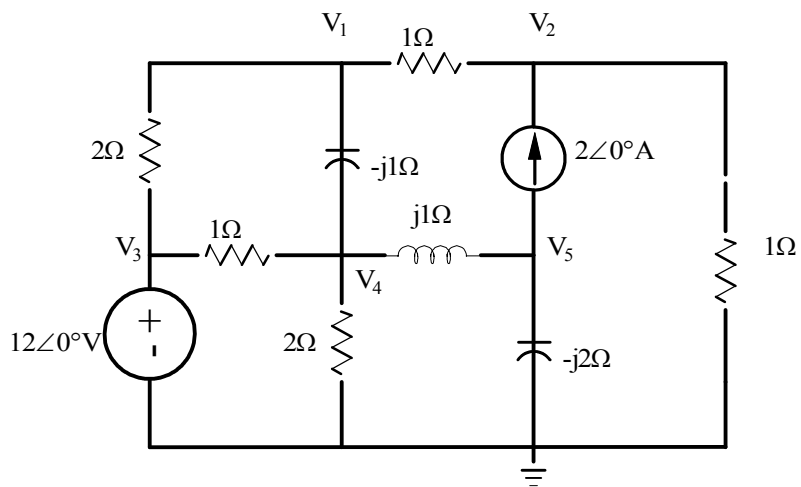

$$\frac{V_1 - V_3}{2} + \frac{V_1 - V_4}{-j1} + \frac{V_1 - V_2}{1} = 0$$

$$\frac{V_2 - V_1}{1} + \frac{V_2}{1} = 2\angle 0^\circ$$

$$V_3 = 12\angle 0^\circ$$

$$\frac{V_4 - V_1}{-j1} + \frac{V_4 - V_3}{1} + \frac{V_4}{2} + \frac{V_4 - V_5}{j1} = 0$$

$$\frac{V_5 - V_4}{j1} + \frac{V_5}{-j2} = -2\angle 0^\circ$$

ALSO

$$V_1(1.5 + j1) - V_2 - .5V_3 - j1V_4 = 0$$

$$-V_1 + 2V_2 = 2\angle 0^\circ$$

$$V_3 = 12\angle 0^\circ$$

$$-j1V_1 - V_3 + 1.5V_4 + j1V_5 = 0$$

$$j1V_4 - j0.5V_5 = -2\angle 0^\circ$$

Matrix Form

$$\begin{bmatrix} 1.5 + j1 & -1 & -.5 & -j1 & 0 \\ -1 & 2 & 0 & 0 & 0 \\ 0 & 0 & 1 & 0 & 0 \\ -j1 & 0 & -1 & 1.5 & j1 \\ 0 & 0 & 0 & j1 & -j0.5 \end{bmatrix} \begin{bmatrix} V_1 \\ V_2 \\ V_3 \\ V_4 \\ V_5 \end{bmatrix} = \begin{bmatrix} 0 \\ 2\angle 0^\circ \\ 12\angle 0^\circ \\ 0 \\ -2\angle 0^\circ \end{bmatrix}$$

```
>>Y = [ 1.5+j*1 -1 -.5 -j*1 0; -1 2 0 0 0; 0 0 1 0 0; -j*1 0 -1 1.5 j*1;
0 0 j*1 -j*0.5]
>>I = [0;2;12;0;-2]
>>V = inv(Y)*I
```

V=

```
6.5800 - 2.0600i
4.2900 - 1.0300i
12.0000 - 0.0000i
4.5200 - 1.6400i
9.0400 - 7.2800i
```

Problem 7.76

Using the PSPICE Schematics editor, draw the circuit shown. At what frequency are the magnitudes of $i_C(t)$ and $i_L(t)$ equal?

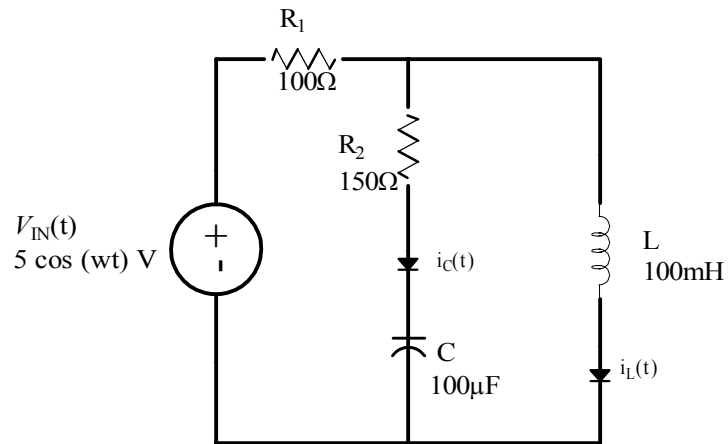

Suggested Solution

This *Schematics* circuit was simulated over the frequency range 100 Hz to 300 Hz. Since current into pin markers were placed in the circuit, PROBE will automatically plot the required current magnitudes.

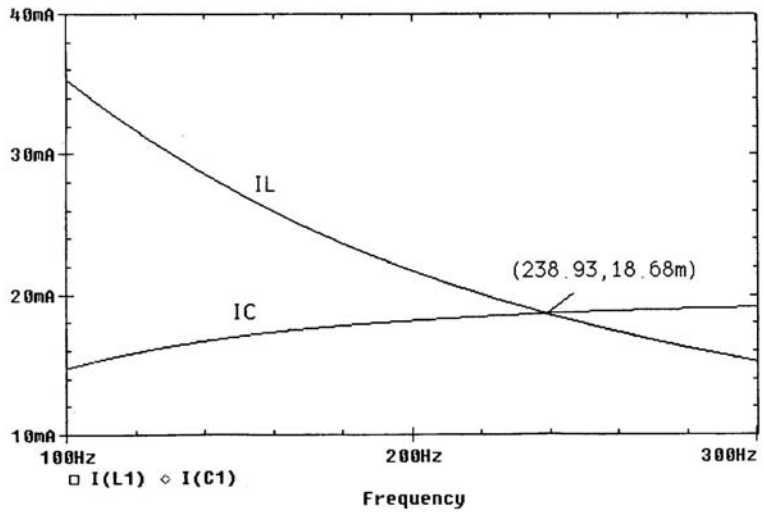
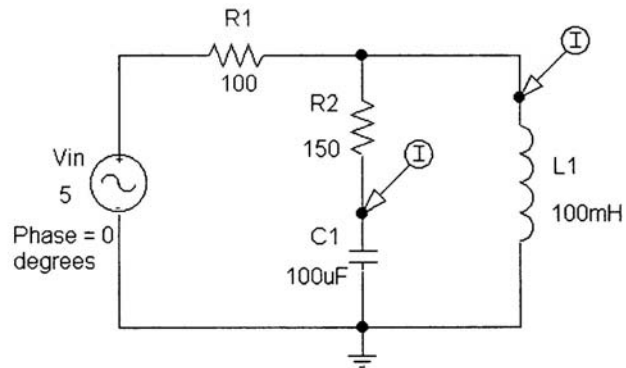

PROBE results show that the voltage and current phases are roughly equal at 238.9 Hz

Problem 7.77

Using the PSPICE Schematics editor, draw the circuit shown. At what frequency are the phases of $i_1(t)$ and $v_x(t)$ equal?

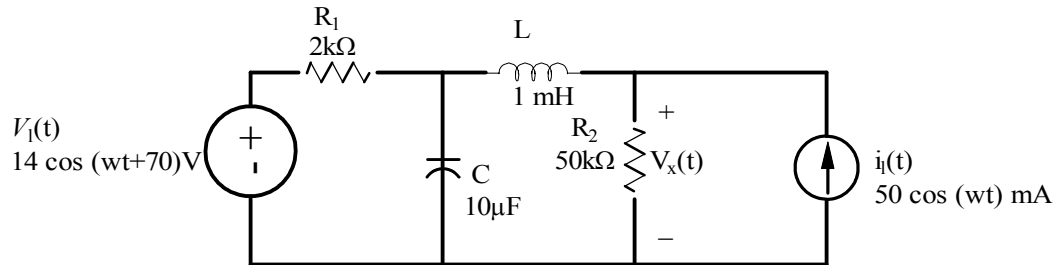

Suggested Solution

This *Schematics* circuit was simulated over the frequency range 1 kHz to 2 kHz. Since vphase and iphase markers were placed in the circuit, PROBE will automatically plot the required voltage and current phase angles.

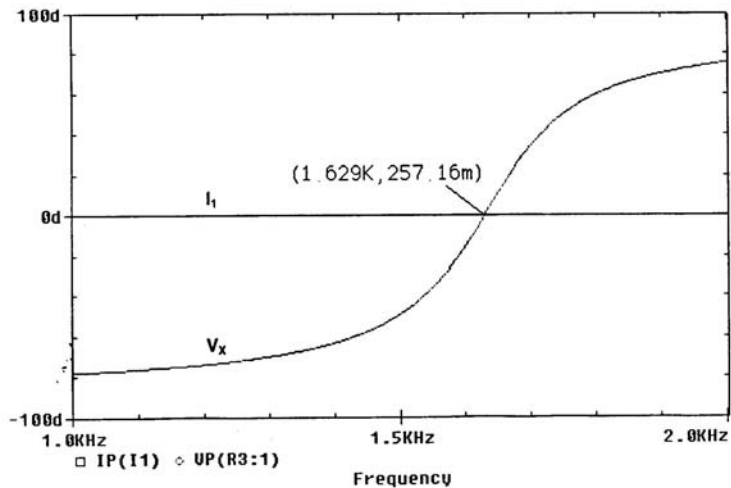
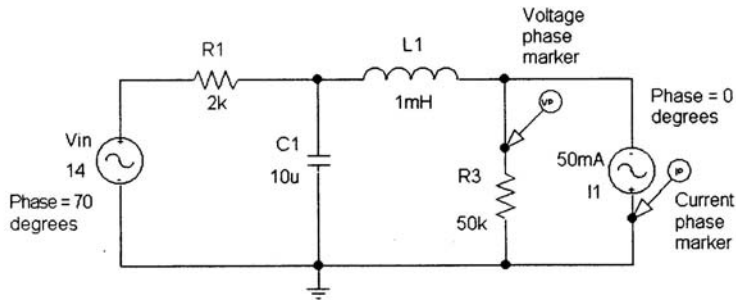

PROBE results show that the voltage and current phases are roughly equal at 1.63 kHz.

Problem 7FE-1

Find V_0 in the network shown.

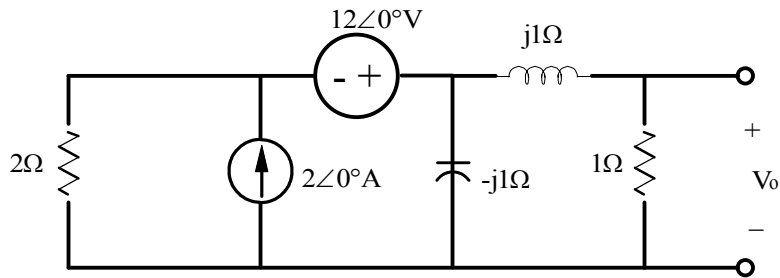

Suggested Solution

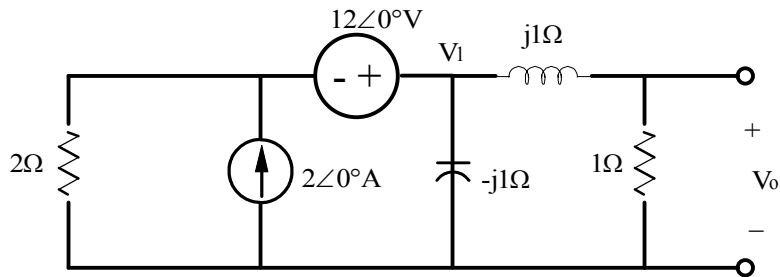

$$\frac{V_1 - 12}{2} - 2 + \frac{V_1}{-j1} + \frac{V_1}{1 + j1} = 0$$

$$V_1 \left[\frac{1}{2} + \frac{1}{-j} + \frac{1}{1 + j} \right] = 8 \quad V_1 = \frac{32}{4 + j2} V$$

$$V_0 = V_1 \left(\frac{1}{1 + j} \right) = \frac{32}{2 + j6} = 5.06 \angle -71.6^\circ V$$

Problem 7FE-2

Find V_0 in the circuit shown.

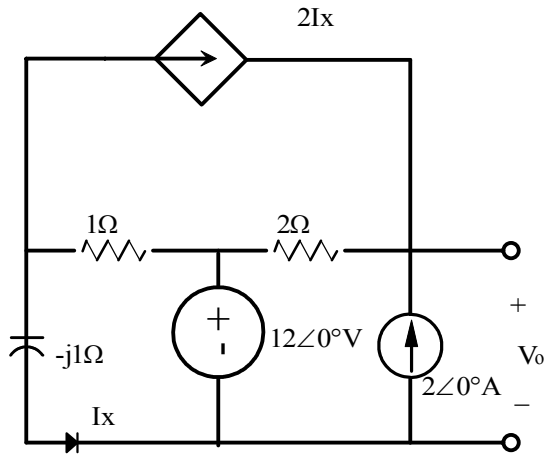

Suggested Solution

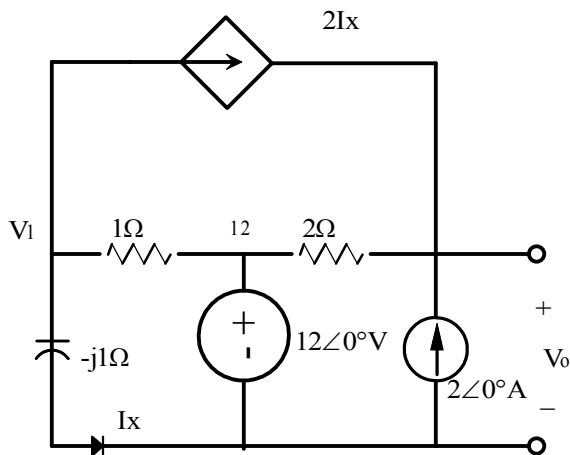

$$\frac{V_1}{-j} + \frac{V_1 - 12}{1} + 2I_x = 0$$

$$\frac{V_0 - 12}{2} - 2 - 2I_x = 0$$

$$I_x = \frac{V_1}{-j}$$

$$V_1 = \frac{12}{1 + 3j} \Rightarrow \frac{V_0}{2} - 2j \left(\frac{12}{1 + 3j} \right) = 8 \Rightarrow V_0 = \frac{304 + j48}{10} = 30.78 \angle 8.97^\circ \text{V}$$

Problem 7FE-3

Find the average power dissipated in the 4-Ohm load resistor.

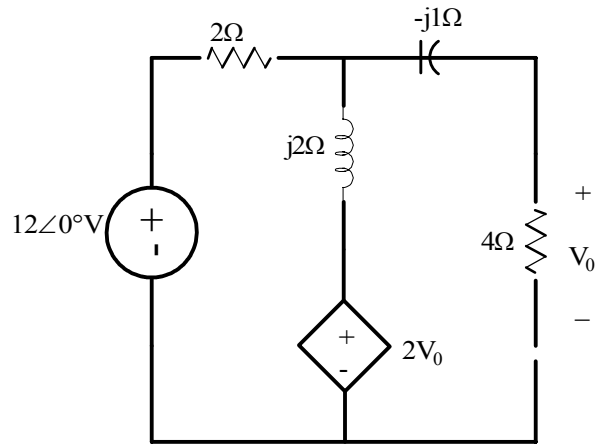

Suggested Solution

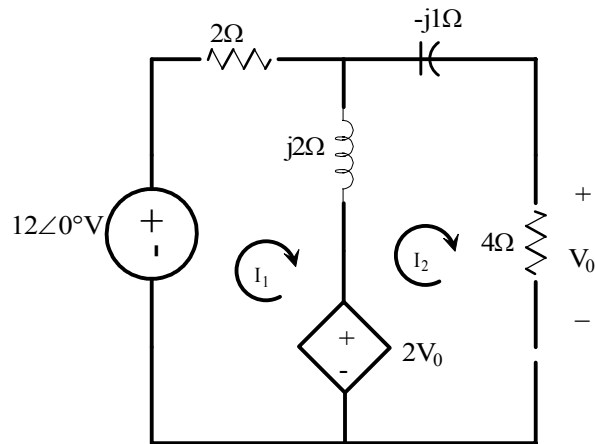

$$-12 + 2I_1 + j2(I_1 - I_2) + 2V_0 = 0$$

$$-2V_0 + j2(I_2 - I_1) - jI_2 + 4I_2 = 0$$

$$V_0 = 4I_2$$

$$I_1(1 + j) + I_2(4 - j1) = 6$$

$$I_1(-j) + I_2\left(-2 + j\frac{1}{2}\right) = 0$$

$$\Delta = (1 + j)\left(-2 + j\frac{1}{2}\right) - (-j)(4 - j) = \frac{-3 - j5}{2}$$

$$\begin{bmatrix} I_1 \\ I_2 \end{bmatrix} = \frac{2}{-3 + j5} \begin{bmatrix} -2 + j\frac{1}{2} & -4 + j \\ j & 1 + j \end{bmatrix} \begin{bmatrix} 6 \\ 0 \end{bmatrix} \Rightarrow I_2 = \frac{60 - j36}{34} = 2.05 \angle -31.03^\circ \text{ A}$$

$$P_{4\Omega} = \frac{1}{2}(2.05)^2(4) = 8.41 \text{ watts}$$

Problem 7FE-4

Determine the mid-band (where the coupling capacitors can be ignored) gain of the single-stage amplifier shown.

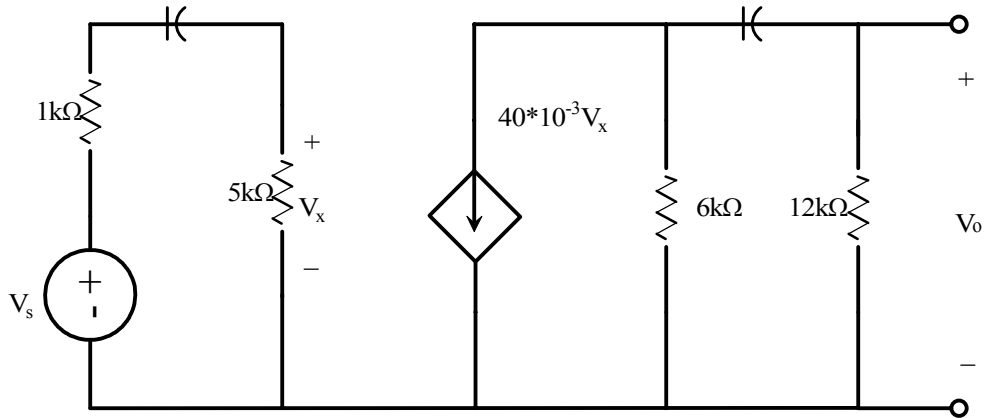

Suggested Solution

$$V_x = \frac{V_s(5k)}{1k + 5k} = \frac{5}{6}V_s \text{ and } V_o = -40 \times 10^{-3} V_x (6k \parallel 12k) = \frac{-40}{1000} \left(\frac{5}{6} \right) (4k) V_s = -133.33 V_s$$

$$\frac{V_o}{V_s} = -133.33$$

Problem 8.1

Given the network in Figure P8.1

- (a) Find the equations for $v_a(t)$ and $v_b(t)$
- (b) Find the equations for $v_c(t)$ and $v_d(t)$

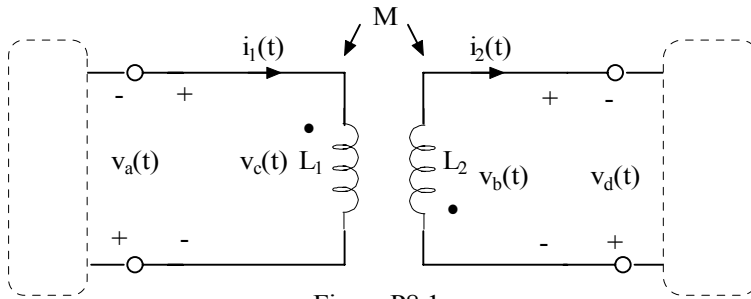

Figure P8.1

Suggested Solution

a)

$$v_a(t) = -L_1 \frac{di_1}{dt} - M \frac{di_2}{dt}$$

$$v_b(t) = -L_2 \frac{di_2}{dt} - M \frac{di_1}{dt}$$

b)

$$v_c(t) = L_1 \frac{di_1}{dt} + M \frac{di_2}{dt}$$

$$v_d(t) = L_2 \frac{di_2}{dt} + M \frac{di_1}{dt}$$

Problem 8.2

Given the network in Figure P8.2 (a) write the equations for $v_a(t)$ and $v_b(t)$ and (b) write the equations for $v_c(t)$ and $v_d(t)$.

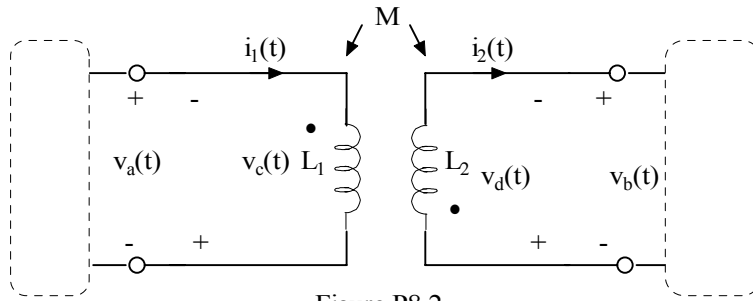

Figure P8.2

Suggested Solution

a)

$$v_a(t) = L_1 \frac{di_1}{dt} + M \frac{di_2}{dt}$$

$$v_b(t) = -L_2 \frac{di_2}{dt} - M \frac{di_1}{dt}$$

b)

$$v_c(t) = -v_a(t) = -L_1 \frac{di_1}{dt} + M \frac{di_2}{dt}$$

$$v_d(t) = -v_b(t) = L_2 \frac{di_2}{dt} + M \frac{di_1}{dt}$$

Problem 8.3

Given the network in Figure P8.3 (a) write the equations for $v_a(t)$ and $v_b(t)$ and (b) write the equations for $v_c(t)$ and $v_d(t)$.

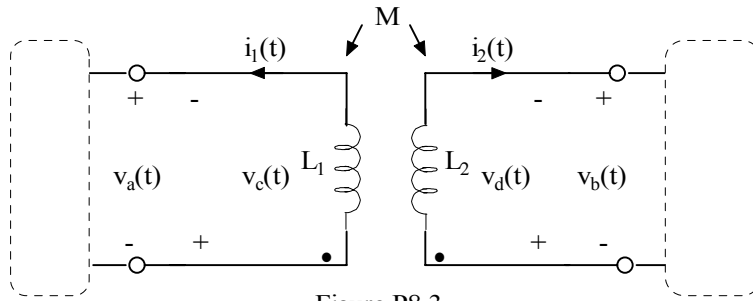

Figure P8.3

Suggested Solution

a)

$$v_a(t) = -L_1 \frac{di_1}{dt} + M \frac{di_2}{dt}$$

$$v_b(t) = -L_2 \frac{di_2}{dt} - M \frac{di_1}{dt}$$

b)

$$v_c(t) = -v_a(t) = -L_1 \frac{di_1}{dt} + M \frac{di_2}{dt}$$

$$v_d(t) = -v_b(t) = L_2 \frac{di_2}{dt} + M \frac{di_1}{dt}$$

Problem 8.4

Given the network in Figure P8.4 (a) write the equations for $v_a(t)$ and $v_b(t)$ and (b) write the equations for $v_c(t)$ and $v_d(t)$.

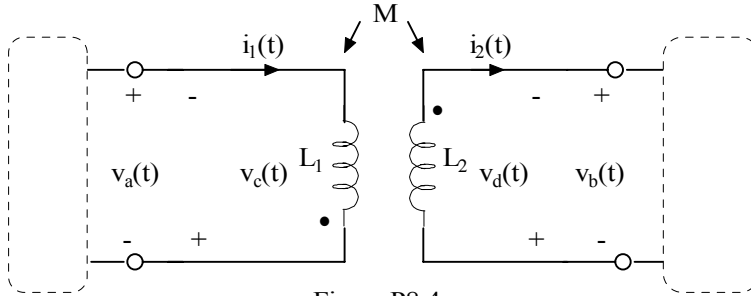

Figure P8.4

Suggested Solution

a)

$$v_a(t) = L_1 \frac{di_1}{dt} + M \frac{di_2}{dt}$$

$$v_b(t) = -L_2 \frac{di_2}{dt} - M \frac{di_1}{dt}$$

b)

$$v_c(t) = -v_a(t) = -L_1 \frac{di_1}{dt} - M \frac{di_2}{dt}$$

$$v_d(t) = -v_b(t) = L_2 \frac{di_2}{dt} + M \frac{di_1}{dt}$$

Problem 8.5

Find the voltage gain V_o/V_s of the network shown in figure P8.5

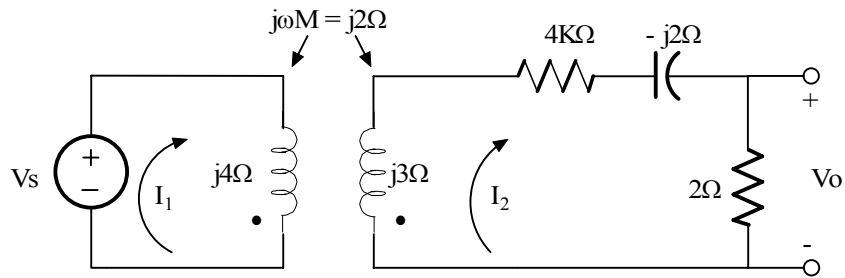
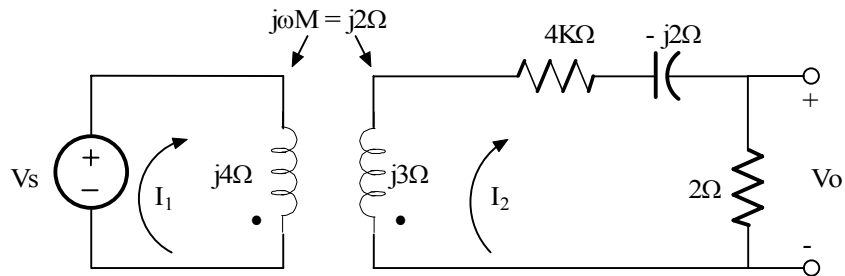

Figure P8.5

Suggested Solution



$$-V_s = 2(-I_1) + j4(-I_1) + j2I_2$$

$$V_s = (2 + j4)I_1 - j2I_2$$

$$0 = -j2I_1 + (6 + j1)I_2$$

$$V_o = 2I_2$$

$$j2I_1 = (6 + j1)I_2 \quad \text{or} \quad I_1 = \frac{6 + j1}{j2}(I_2)$$

then

$$V_s = (2 + j4)\left(\frac{6 + j1}{j2}\right)I_1 - j2I_2 = (13 - j6)I_2$$

$$I_2 = \frac{V_s}{3 - j6} \quad \text{or} \quad V_o = 2I_2 = \frac{2V_s}{13 - j6} = \frac{V_o}{V_s} = \frac{2}{13 - j6} = \boxed{0.140 \angle 24.78^\circ}$$

Problem 8.6

Find the voltage gain V_o/V_s of the network shown in figure P8.6

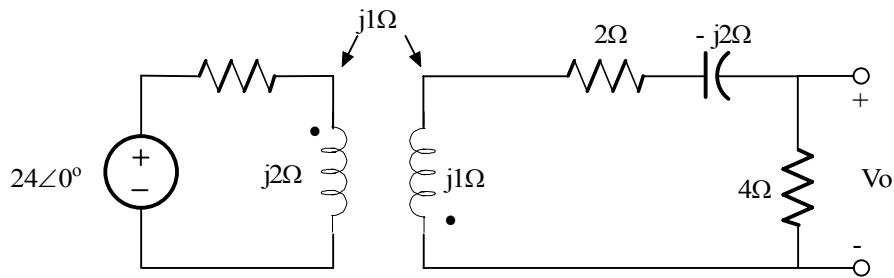
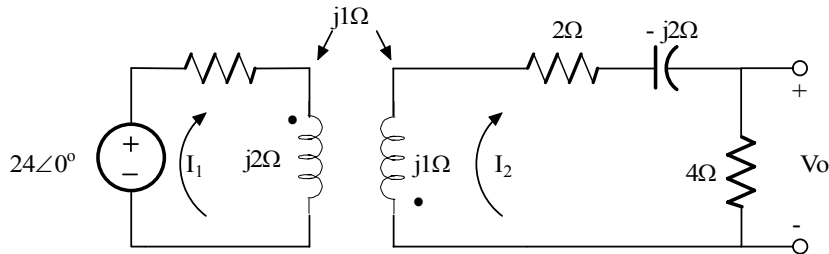

Figure P8.6

Suggested Solution



$$\begin{aligned} 24 &= (2+j2)I_1 + j1 I_2 \\ 0 &= jI_1 + (6-j)I_2 \\ V_o &= 4I_2 \end{aligned}$$

$$\begin{aligned} -j I_1 &= (6 - j)I_2 \text{ or } I_1 = (1 + j6)I_2 \\ 24 &= (2 + j2)(1 + j6)I_2 + jI_2 \\ I_2 &= 24 / (-10 + j5) \quad V_o = 4 \times 24 / (-10 + j15) \end{aligned}$$

$5.33 \angle -123^\circ \text{ V}$

Problem 8.7

Find V_o in the network in Figure P8.7

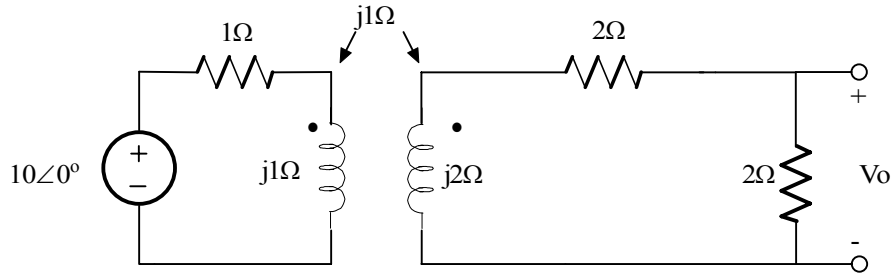
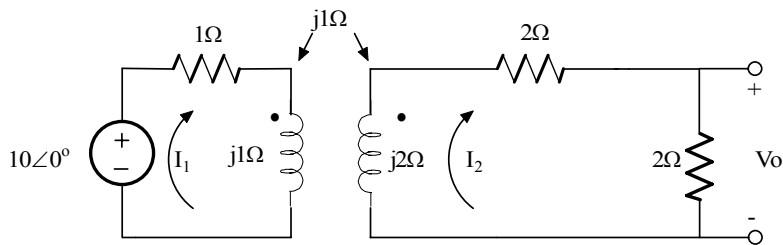

Figure P8.7

Suggested Solution



Loop equations

$$10 = (1+j1)I_1 - j1 I_2 \quad (1)$$

$$0 = -jI_1 + (4+2j)I_2 \quad (2)$$

Solve (2) for I_1 and substitute into (1) and get I_2

$$I_1 = I_2 (4 + j2) / j1 = I_2 (2 - j4)$$

$$10 = [(1 + j1)(2 - j4) - j1] I_2 = (2 + 4 + j2 - j4 - j1) I_2 = (6 - j3) I_2$$

$$I_2 = 10 / (6 - j3) \quad V_o = 2 I_2 = 20 / (6 - j3)$$

$V_o = 2.98 \angle 26.57^\circ \text{ V}$

Problem 8.8

Given the network in Figure P8.8 find V_o

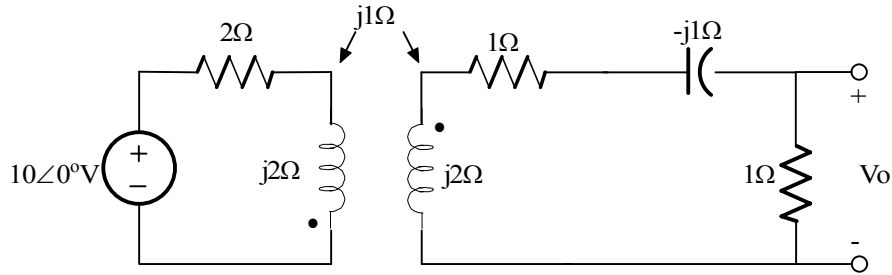
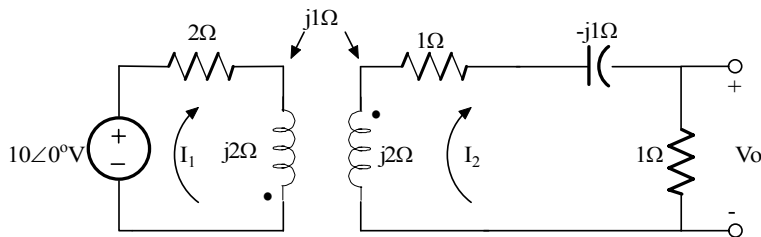

Figure P8.8

Suggested Solution



$$10 = (2 + j2)I_1 + j1 I_2 \quad (1)$$

$$0 = j1I_1 + (2 + 2j)I_2 \quad (2)$$

Solve (2) for I_1 and substitute into (1) and get I_2

$$I_1 = -I_2 (2 + j1) / j1 = I_2 (-1 + j2)$$

$$10 = [j1 - (-1 + j2)(2 + j2)] I_2 = (-2 - 4 - j2 + j4 + j1)I_2 = (-6 + j3) I_2$$

$$I_2 = 10 / (-6 + j3) = 10 / (-6 + j3)$$

$V_o = 1.49 \angle -153.43^\circ \text{ V}$

Problem 8.9

Find V_o in the circuit in Figure P8.9

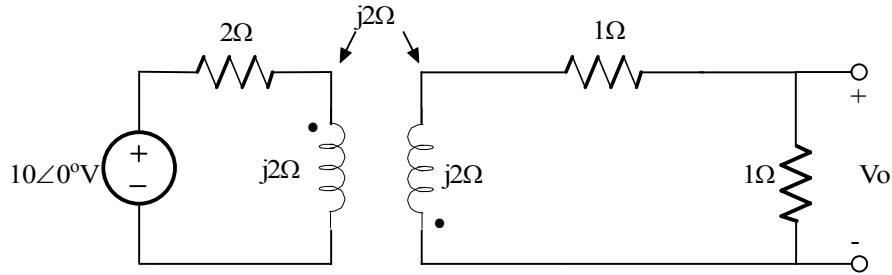
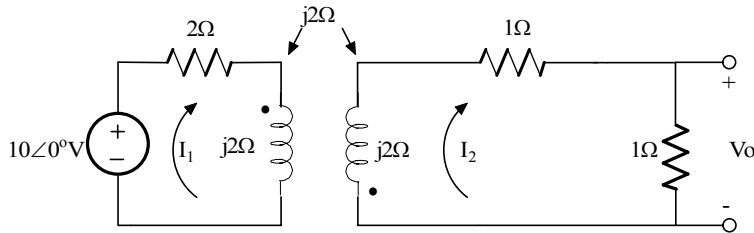

Figure 8.9

Suggested Solution



$$10 = (2 + j2)I_1 + j2 I_2 \quad (1)$$

$$0 = j2I_1 + (2 + j2)I_2 \quad (2)$$

Solve (2) for I_1 and substitute into (1) and get I_2

$$I_1 = -I_2(2 + j2) / j2 = -I_2(2 - j1)$$

$$10 = [j2 - (1 - j1)(2 + j2)] I_2 = (j2 - 2 - 2 + j2 - j2)I_2 = (6 - j3) I_2$$

$$I_2 = 10 / (-4 + j2) = 5 / (-2 + j)$$

$V_o = 2.24\angle -153.43^\circ \text{ V}$

Problem 8.10

Find V_o in the network in Figure P8.10

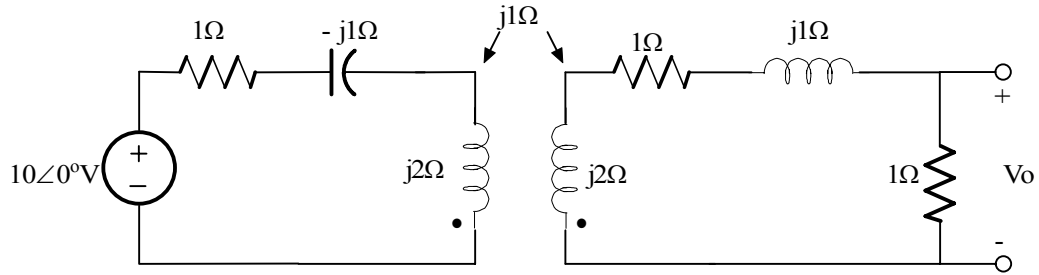
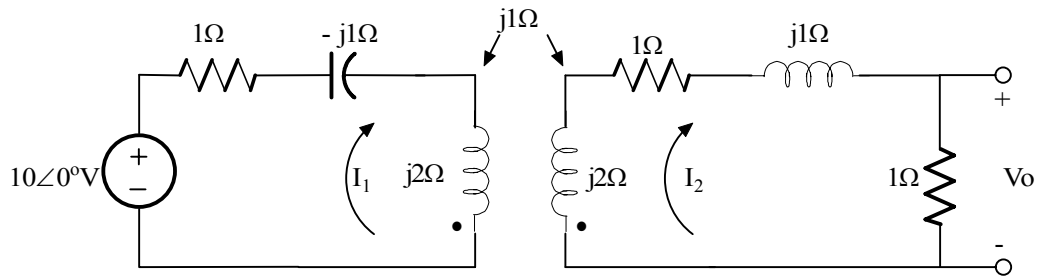

Figure P8.10

Suggested Solution



$$10 = (1 + j1)I_1 - j1 I_2 \quad (1)$$

$$0 = -j1I_1 + (2 + j3)I_2 \quad (2)$$

Solve (2) for I_1 and substitute into (1) and get I_2

$$I_1 = I_2 (2 + j3) / j1 = I_2 (3 - j2)$$

$$10 = [-j1 - (1 + j1)(3 - j2)] I_2 = (3 + 2 + j3 - j2 - j1)I_2 = (5) I_2$$

$$I_2 = 2A$$

$V_o = (1) I_2 = 2\angle 0^\circ \text{ V}$

Problem 8.11

Find V_o in the network in Figure P8.11

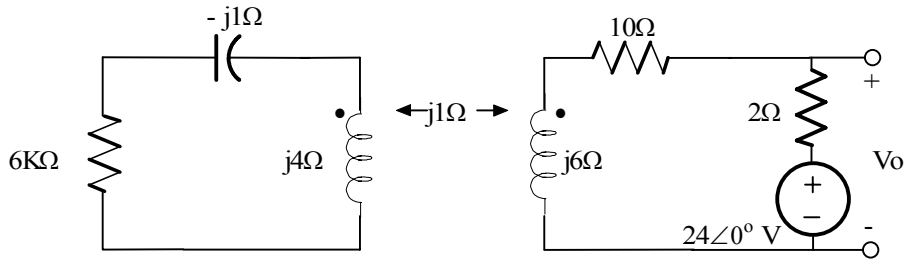
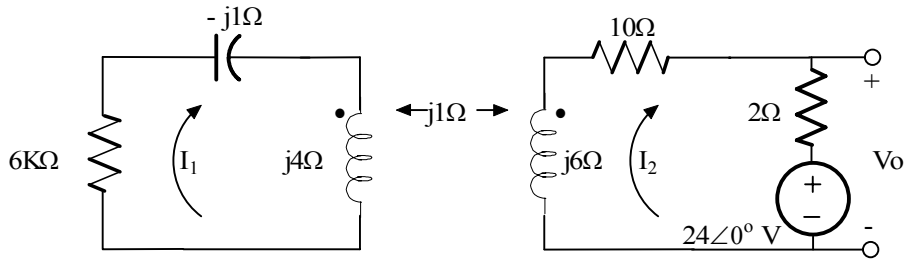

Figure 8.11

Suggested Solution



$$\begin{aligned} (6 + j3) I_1 - jI_2 &= 0 \\ -jI_1 + (12 + j6)I_2 &= -24 \\ V_o &= 2I_2 + 24 \end{aligned}$$

$$\begin{aligned} I_1 &= jI_2 / (6 + j3) \Rightarrow -j(j / (6 + j3)) I_2 + (12 + j6) I_2 = -24 \\ I_2 &= -24(6 + j3) / (55 + j72) = -1.78 \angle -26.1^\circ \end{aligned}$$

$$V_o = 2 I_2 + 24 = 20.86 \angle 4.32^\circ \text{ V}$$

Problem 8.12

Find V_o in the network in Figure P8.12

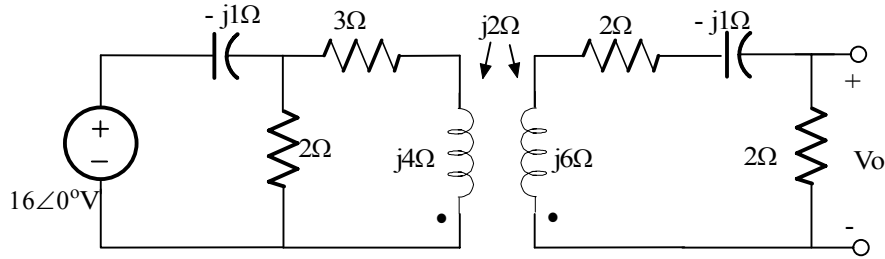
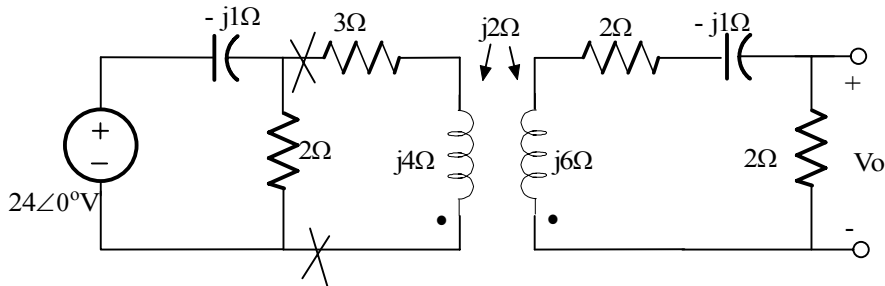

Figure P8.12

Suggested Solution



Forming a Thevenin equivalent at the input

$$V_{oc} = 16(2)/(2 - j) = 32 / (2 - j) \quad \text{and} \quad Z_{th} = -2j / (2 - j)$$

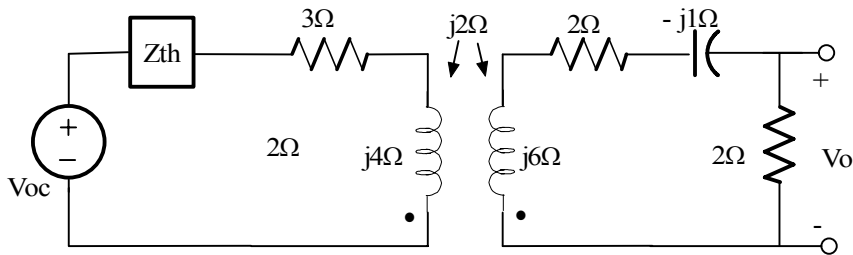

$$32 / (2 - j) = I_1 ((-2j) / (2 - j) + 3 + j4) - j2I_2$$

$$0 = -j2I_1 + (4 + 5j) I_2 \Rightarrow I_1 + (4 + 5j) I_2 \Rightarrow I_1 = [(4 + 5j) / j2] I_2$$

$$32 = [(30 + 3j)(4 + 5j) / j2 - (2 + j4)] I_2 \Rightarrow I_2 = 64j / (33 + j58)$$

$$V_o = 2I_2 = 1.92 \angle 29.64^\circ \text{V}$$

Problem 8.13

Find V_o in the circuit in Figure P8.13

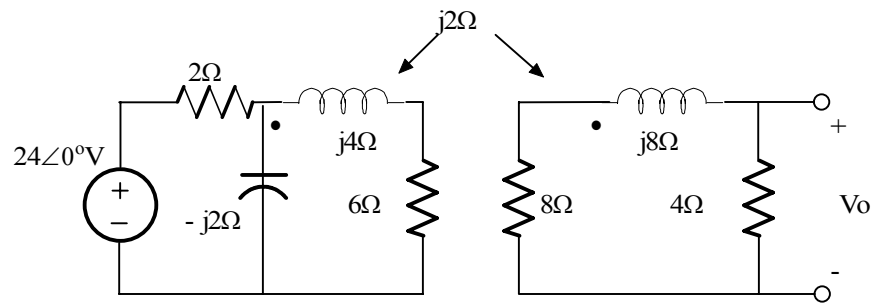
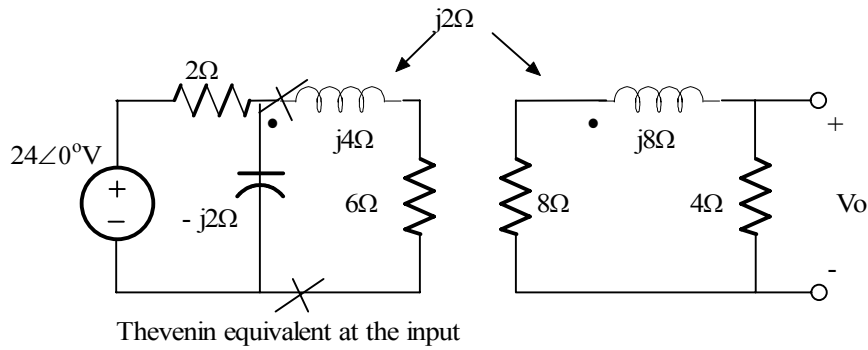
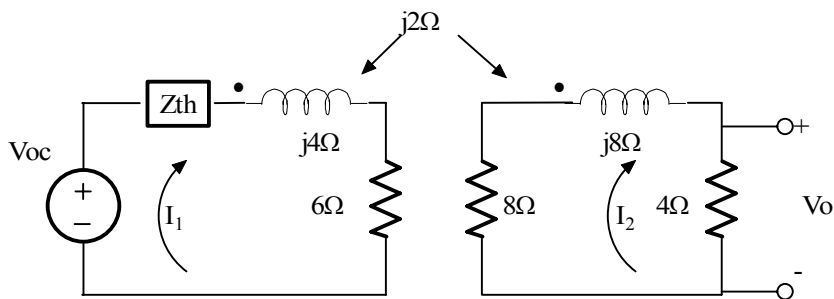

Figure P8.13

Suggested Solution



$$V_{oc} = 24(-j2) / (2 - j2) = -24j(1 - j) \quad \text{and} \quad Z_{th} = -4j / (2 - j2) = -2j / (1 - j)$$



$$-24j / (1 - j) = I_1 (-2j / (1 - j) + 6 + j4) + j2 I_2$$

$$0 = j2 I_1 + (12 + j8) I_2 \Rightarrow I_1 = (-4 + j6) I_2$$

$$-24j = [(-4 + j6)(10 - j4) + 2 + j2] I_2$$

$$I_2 = -24j / (-14 + j78) = 24j / (14 - j78)$$

and

$$V_o = 4I_2 = 1.21 \angle 169.8^\circ \text{V}$$

Problem 8.14

Find I_o in the circuit in Figure 8.14

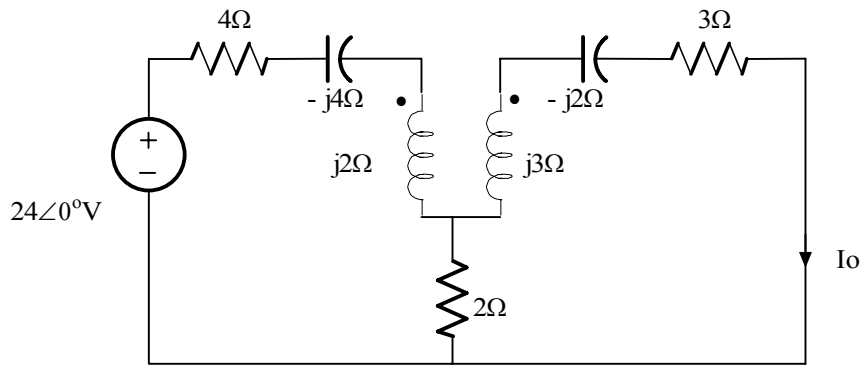

Figure P8.14

Suggested Solution

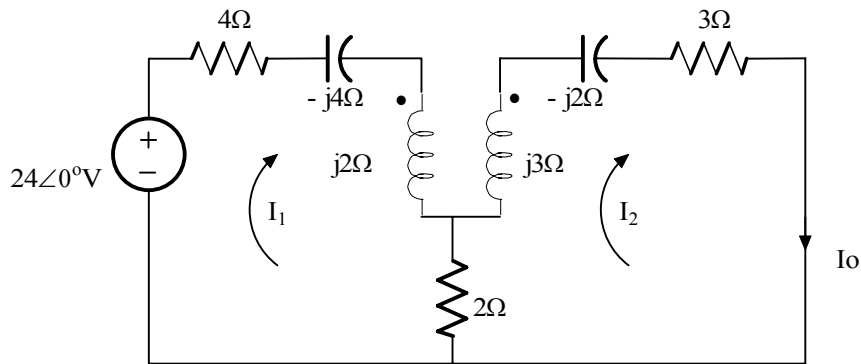

Figure P8.14

$$24 = (6 - j2) I_1 - (2 + j1) I_2$$

$$0 = -(2 + j1) I_1 + (5 + j) I_2$$

$$I_1 = (5 + j) / (2 + j) I_2$$

$$24 = [(6 - j2)(5 + j) / (2 + j)] I_2 - (2 + j) I_2$$

$$I_2 = 1.78 \angle 42^\circ \text{ A}$$

Problem 8.15

Write the mesh equations for the network in Figure P8.15

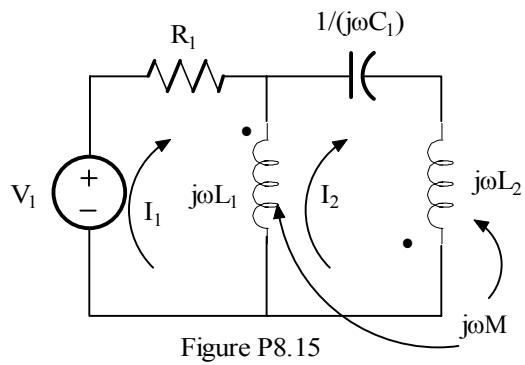

Suggested Solution

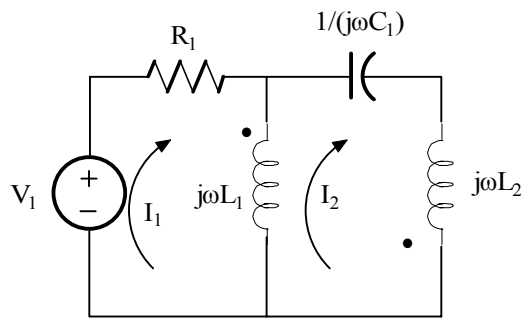

$$V_1 = R_1 I_1 + j\omega L_1(I_1 - I_2) - j\omega M I_2$$

$$0 = j\omega L_1(I_2 - I_1) + j\omega M I_2 + I_2(1/(j\omega C_1)) + j\omega C_2 I_2 + j\omega M(I_2 - I_1)$$

Problem 8.16

Write the mesh equations for the network shown in Figure P8.16

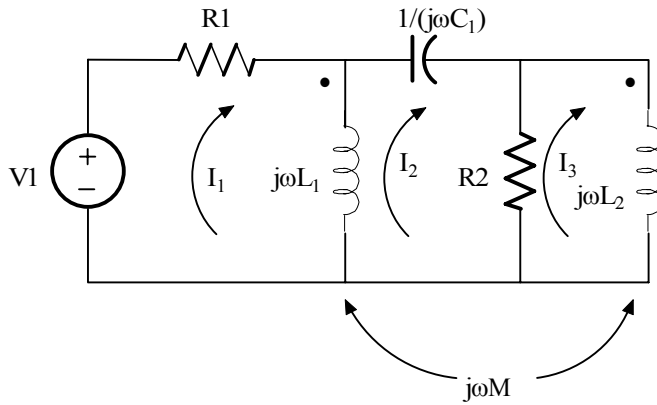

Suggested Solution

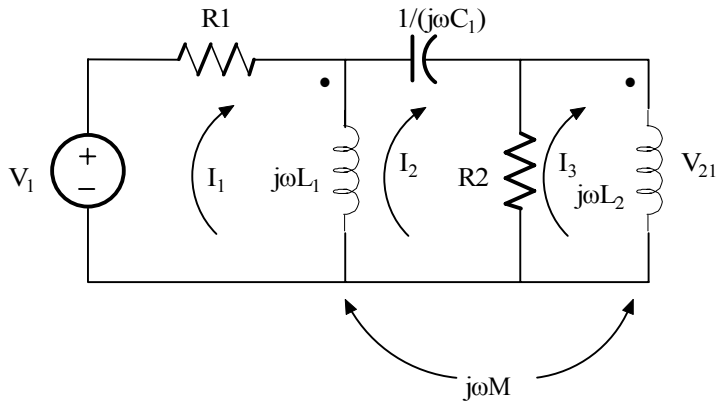

Induced voltages are $V_{12} = +j\omega M I_3$ and $V_{21} = +j\omega M (I_1 - I_2)$

$$V_1 = I_1(R_1 + j\omega L_1) - j\omega L_1 I_2 + I_3 j\omega M$$

$$0 = -j\omega L_1 I_1 + I_2 (R_2 + j\omega L_1 - j / (\omega C_1)) - I_3 (R_2 + j\omega M)$$

$$0 = j\omega M I_1 - (R_2 + j\omega M) I_2 + I_3 (R_2 + j\omega L_2)$$

Problem 8.17

Write the mesh equations for the network shown in Figure P8.17

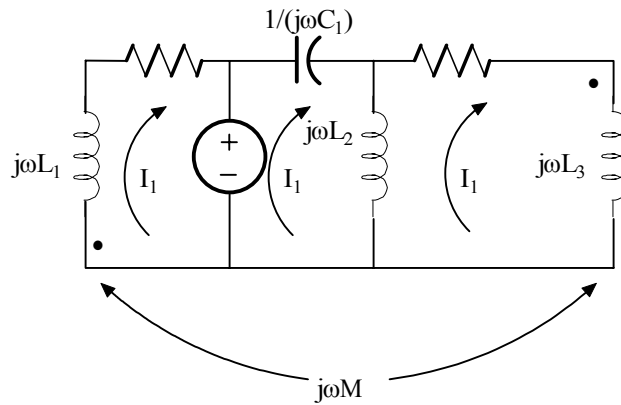

Suggested Solution

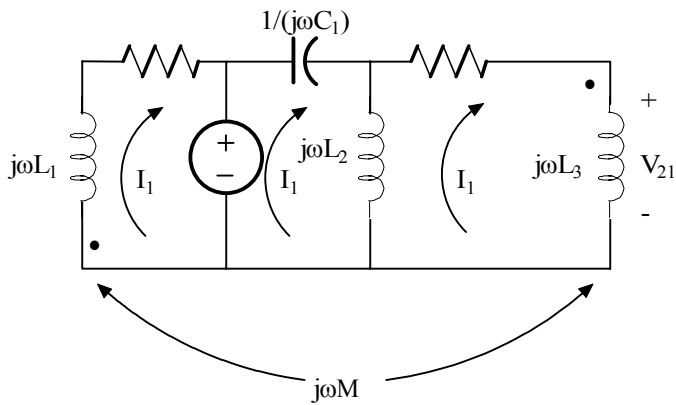

Induced voltages are $V_{12} = -j\omega MI_3$ and $V_{21} = +j\omega MI_1$

$$-V_1 = I_1(R_1 + j\omega L_1) - j\omega MI_3$$

$$0 = I_2(j\omega L_2 - j/(\omega C_1)) - j\omega L_2 I_3$$

$$0 = +j\omega MI_1 - j\omega L_2 I_2 + I_3(R_2 + j\omega L_2 + j\omega L_3)$$

Problem 8.18

Write the mesh equations for the network shown in Figure P8.18

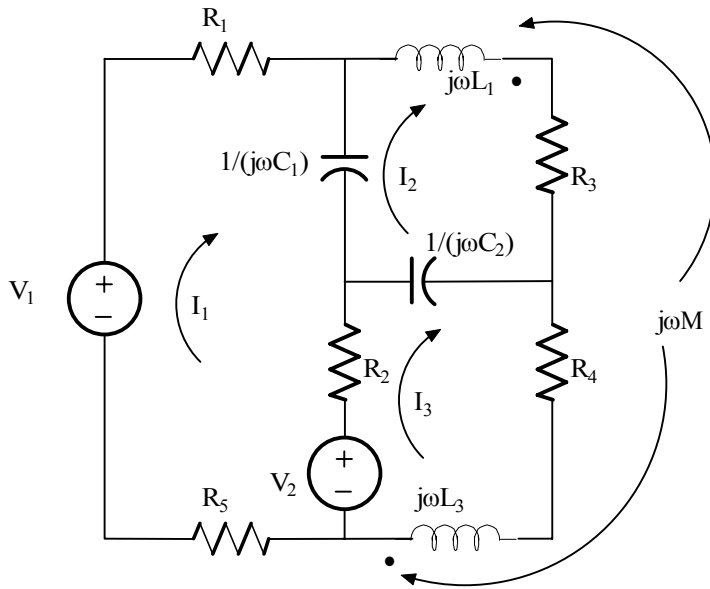
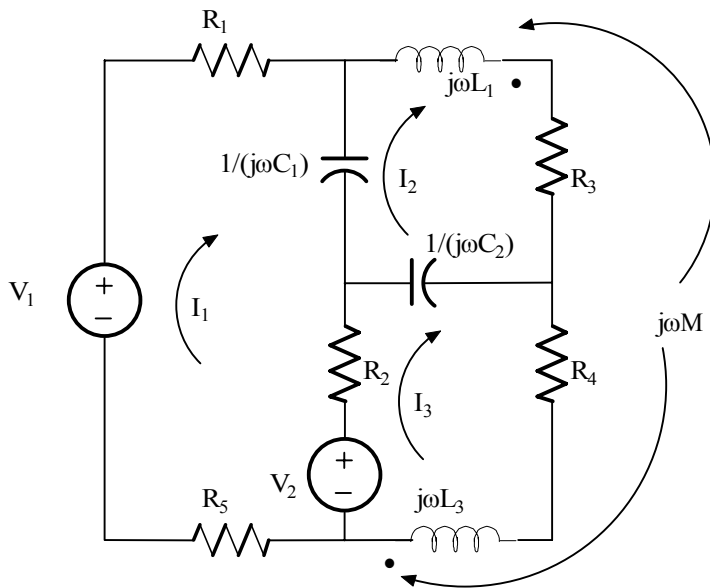

Figure P8.18

Suggested Solution



$$V_1 - V_2 = I_1 (R_1 + R_2 + R_5 + 1/(j\omega C_1)) - 1/(j\omega C_1) I_2 - R_2 I_3$$

$$0 = - 1/(j\omega C_1) I_1 + I_2 (R_3 + j\omega L_1 + 1/(j\omega C_1) + 1/(j\omega C_2)) + I_3 (j\omega M - 1/(j\omega C_2))$$

$$V_2 = - R_2 I_1 + I_2 (j\omega M - 1/(j\omega C_2)) + I_3 (R_2 + R_4 + j\omega L_3 + 1/(j\omega C_2))$$

Problem 8.19

Write the mesh equations for the network shown in Figure P8.19

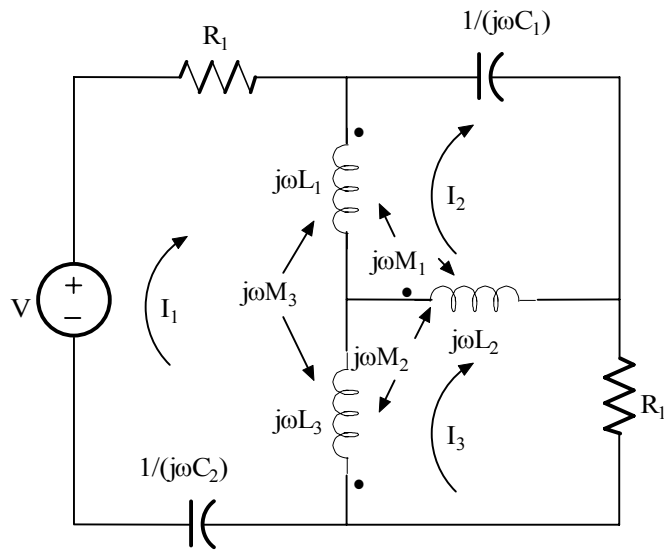
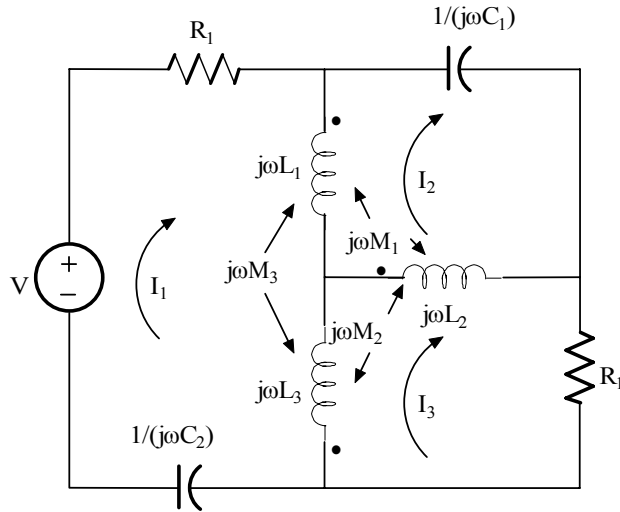

Figure P8.19

Suggested Solution



Induced voltages (positive @ dot)

IN	VIA	EXPRESSION	NAME
L ₁	M ₁	$j\omega M_1(I_3 - I_2)$	V ₁₁
L ₁	M ₃	$j\omega M_1(I_3 - I_1)$	V ₁₃
L ₂	M ₁	$j\omega M_1(I_1 - I_2)$	V ₂₁
L ₂	M ₂	$j\omega M_1(I_3 - I_1)$	V ₂₂
L ₃	M ₂	$j\omega M_1(I_3 - I_2)$	V ₃₂
L ₃	M ₃	$j\omega M_1(I_1 - I_2)$	V ₃₃

Mesh equations

$$V = I_1 (R_1 + j\omega L_1 + j\omega L_3 + 1/(j\omega C_2)) - I_2 j\omega L_1 - I_3 j\omega L_3 + V_{11} + V_{13} - V_{32} - V_{33}$$

$$0 = -I_1 j\omega L_1 + I_2 (j\omega L_1 + j\omega L_2 + 1/(j\omega C_1)) - I_3 j\omega L_2 + -V_{11} - V_{13} - V_{21} - V_{22}$$

$$0 = -I_1 j\omega L_1 + I_2 (j\omega L_2 + I_3 (R_2 + j\omega L_2 + j\omega L_3)) + V_{21} + V_{22} + V_{32} + V_{33}$$

$$\text{Let } Z_1 = R_1 + j\omega L_2 + j\omega L_3 + 1/(j\omega C_2); \quad Z_2 = j\omega L_1 + j\omega L_2 + (1/j\omega C_1); \quad Z_3 = R_2 + j\omega L_2 + j\omega L_3$$

Substituting from the table above:

$$V = I_1 (Z_1 - j\omega Z M_3 + I_2 [j\omega M (M_2 + M_3 - M_1 - L_1)] + I_3 [j\omega (M_1 + - M_2 + M_3 - L_2)])$$

$$0 = I_1 [j\omega (M_3 - M_1 + M_2 - L_1)] + I_2 [Z_2 + j\omega Z M_1] - I_3 [j\omega (M_1 + M_2 + M_3 + L_2)]$$

$$0 = I_1 [j\omega (M_1 - M_2 + M_3 - L_2)] - I_2 [j\omega (M_1 + M_2 + M_3 + L_2)] + I_3 (Z_3 + j\omega 2M_2)$$

Problem 8.20

Find V_o in the network in Figure P8.20

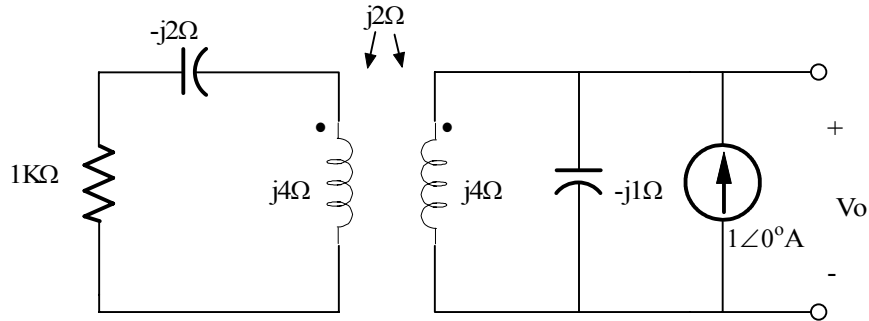

Suggested Solution

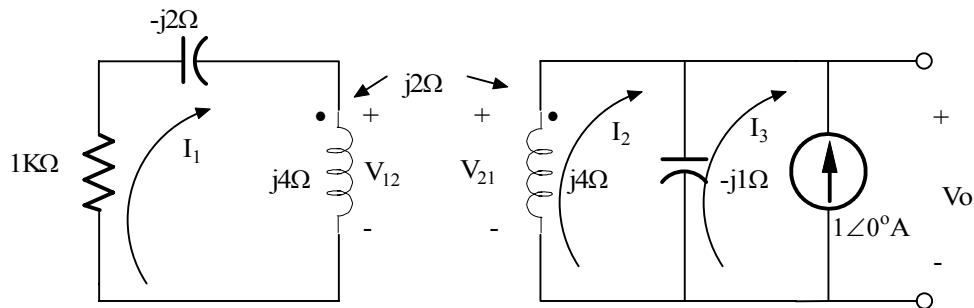

$$\text{Induced voltages: } V_{12} = -j2I_2 \quad V_{21} = +j2I_1$$

$$0 = I_1 (4 + j2) - j2I_2 \quad \text{and} \quad 0 = I_2(j3) + j1I_3 - j2I_1 \quad \text{and} \quad I_3 = -1 \angle 0^\circ \text{A}$$

$$\text{From 1st equation: } I_1 = I_2 [1 / (1 - j2)]$$

$$\text{Now: } 0 = I_2 [j3 - j2 (1 - j2)] + j1I_3 \quad \text{and} \quad I_3 = -1$$

$$\text{or: } I_2 [(6 + j3 - j2) / (1 - j2)] = j1 \quad \text{or} \quad I_2 = (2 + j1) / (6 + j1) = 0.37 \angle 17.10^\circ \text{A}$$

$$V_o = (I_2 - I_3) (-j1) = [0.37 \angle 17.10^\circ + 1 \angle 0^\circ] (1 \angle -90^\circ)$$

$V_o = 1.36 \angle -85.4^\circ \text{V}$

Problem 8.21

Find V_o in the network in Figure P8.21

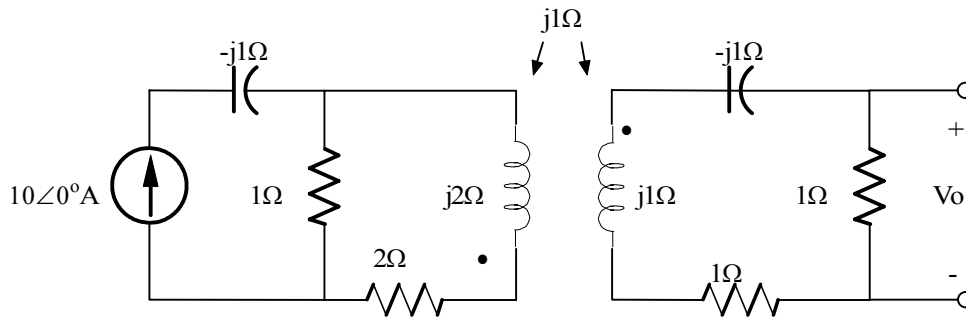
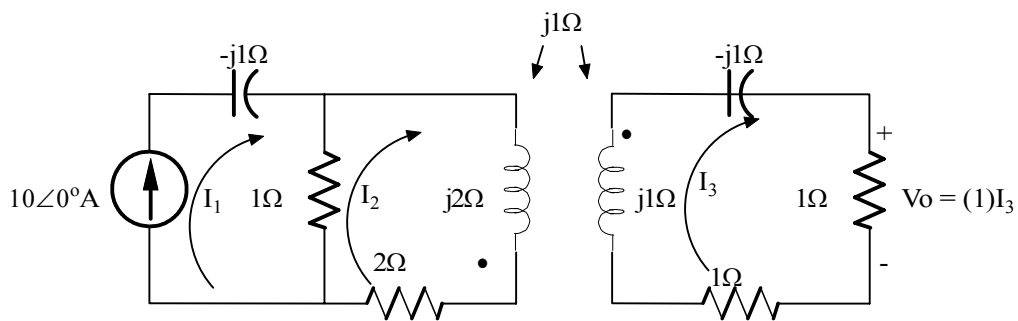

Figure P8.21

Suggested Solution



$$I_1 = 10\angle 0^\circ \text{A} \quad (1)$$

$$0 = -I_1 + I_2(3 + j2) + j1I_3 \quad (2)$$

$$0 = +j1I_2 + I_3(2) \quad (3)$$

Solve (3) for I_2 and substitute into (2) along with (1).

$$I_2 = (j2)I_3$$

$$0 = -10 + [(3 + j2)(j2) + j1]I_3 \Rightarrow I_3 = 10 / (-4 + j7) = 1.24\angle -119.74^\circ \text{A}$$

$$V_o = (1) I_3 = 1.24\angle -110.74^\circ \text{V}$$

Problem 8.22

Find V_o in the network in Figure P8.22

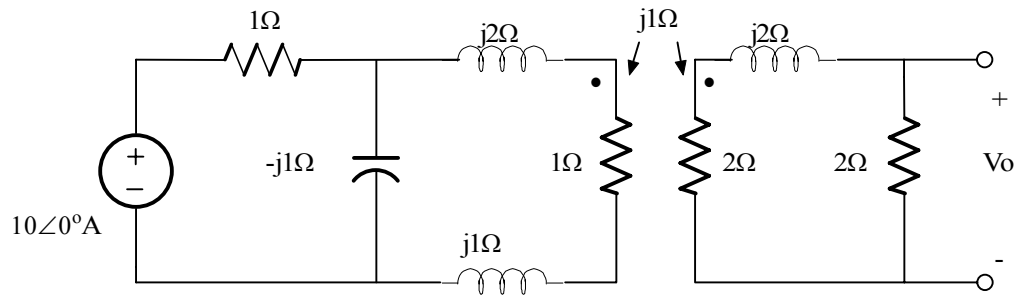
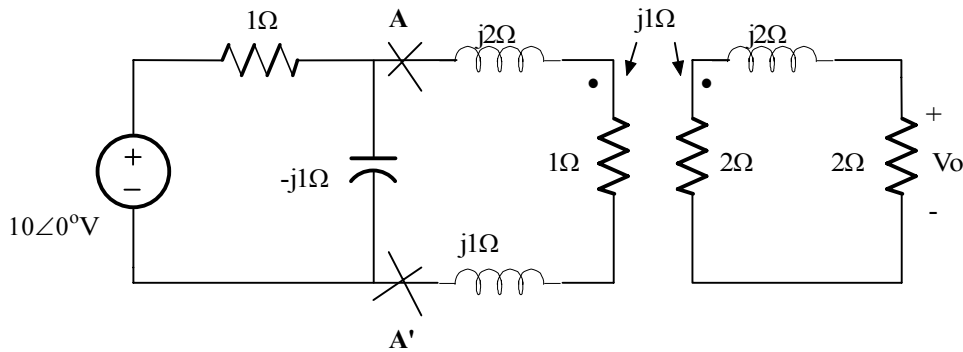
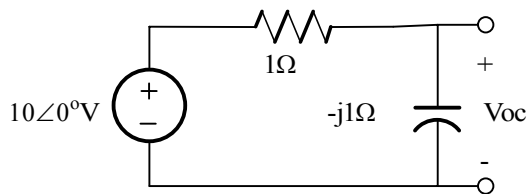

Figure P8.22

Suggested Solution



Thevenin Eq. at A - A'



$$V_{oc} = (-j1)/(1 - j1) (10) = 7.07\angle-45^\circ\text{V}$$

$$Z_{th} = 1 \parallel (-j1) = 1/2 - j1/2 \Omega$$

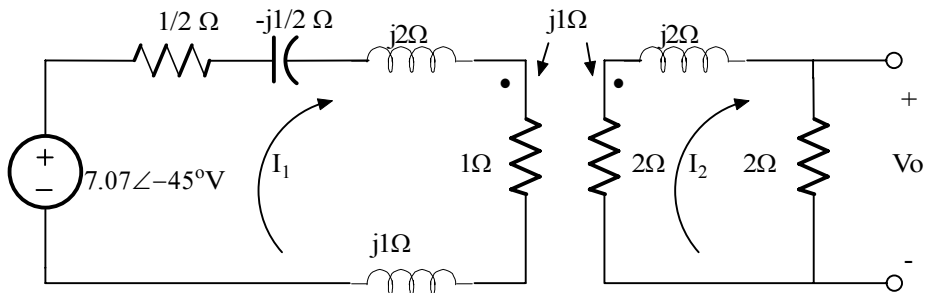

$$7.07\angle-45^\circ = I_1 (1.5 + j2.5) - j1 I_2 \quad (1)$$

$$0 = -j1 I_1 + I_2 (4 + j2) \quad (2)$$

Solve (2) for I_1 and substitute into (1), solve for I_2

$$7.07\angle-45^\circ = [(2 - j4) (1.5 + j2.5) - j1] I_2 = [13 - j2] I_2$$

$$I_2 = (7.07\angle-45^\circ) / (13 - j2) = 7.54\angle-36.25^\circ\text{A}$$

$$V_o = 2I_2 = 1.08\angle-36.25^\circ\text{V}$$

Problem 8.23

Find V_o in the network in Figure P8.23

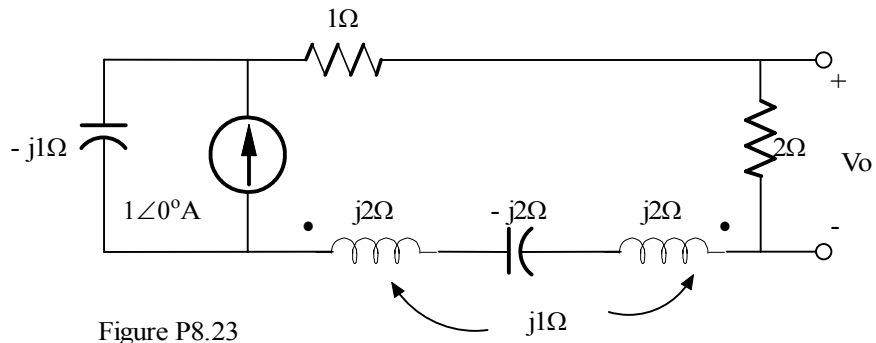

Suggested Solution

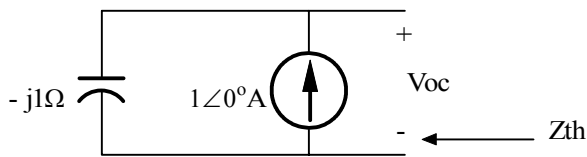
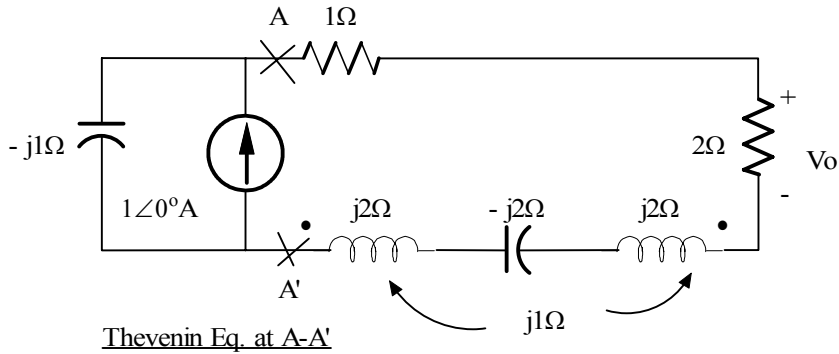

$$V_{oc} = (-j1)(1) = 1\angle-90^\circ\text{V}$$

$$Z_{th} = -j1\Omega$$

New Circuit

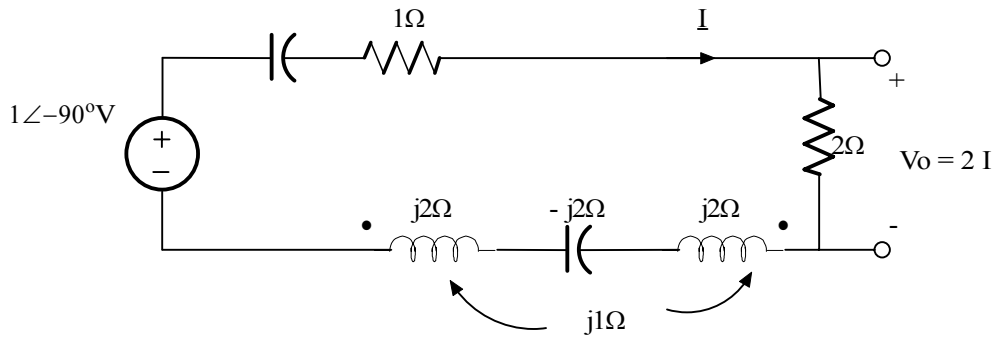

$$1\angle-90^\circ\text{V} = I(3 - j1 + j2 - j2 + j2) - j1 I - j1 I \text{ (induced)}$$

$$I = 1\angle-90^\circ / (3 - j1) = 0.32\angle-71.57^\circ\text{A}$$

$$V_o = 2I = 0.64\angle-71.57^\circ\text{V}$$

Problem 8.24

Find V_o in the network in Figure P8.24

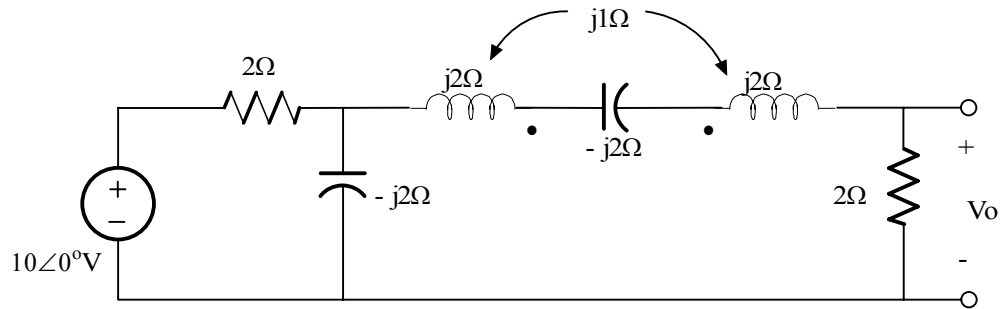
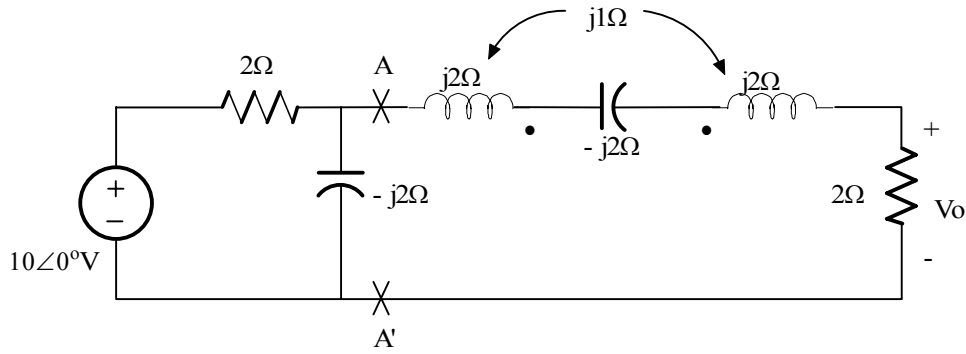
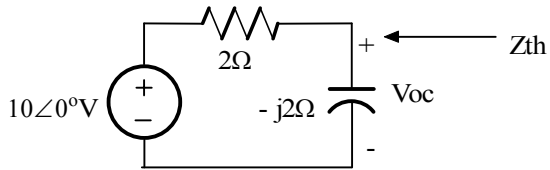

Figure P8.24

Suggested Solution



Thevenin Eq. at A - A'



$$V_{oc} = 10 (-j2) / (2 - j2) = 7.07 \angle -45^\circ \text{V}$$

$$Z_{th} = 2 \parallel (-j2) = 1 - j1 \Omega$$

New Circuit

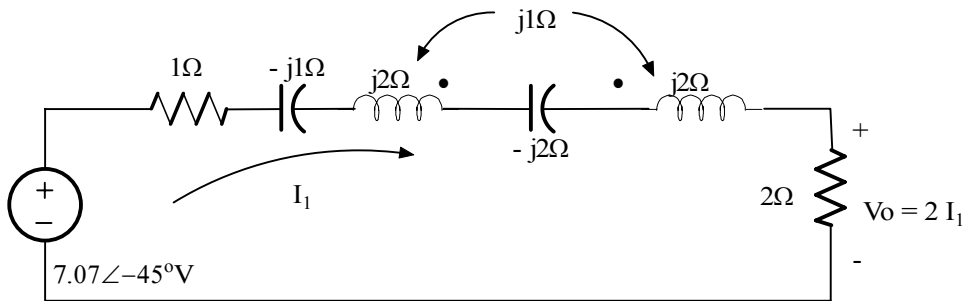

$$7.07 \angle -45^\circ = I_1 (1 - j1 + j2 - j2 + j2 + 2) - j1 I_1 - j1 I_1$$

(induced voltages)

$$I_1 = (7.07 \angle -45^\circ) / (3 - j1) = 2.24 \angle -26.57^\circ \text{A}$$

$$V_o = 2I_1 = 4.48 \angle -26.57^\circ$$

Problem 8.25

Find V_o in the network in Figure P8.25

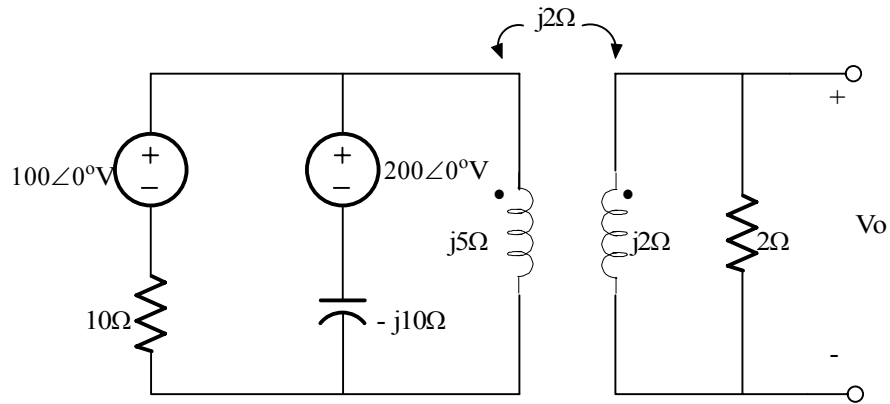
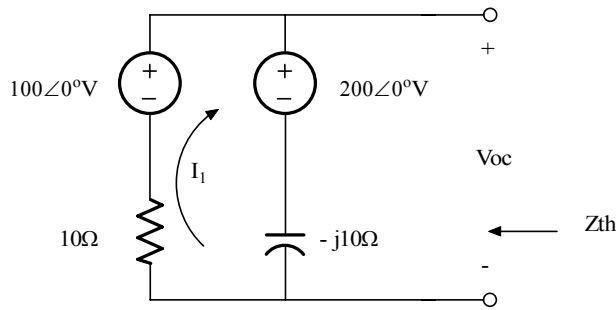
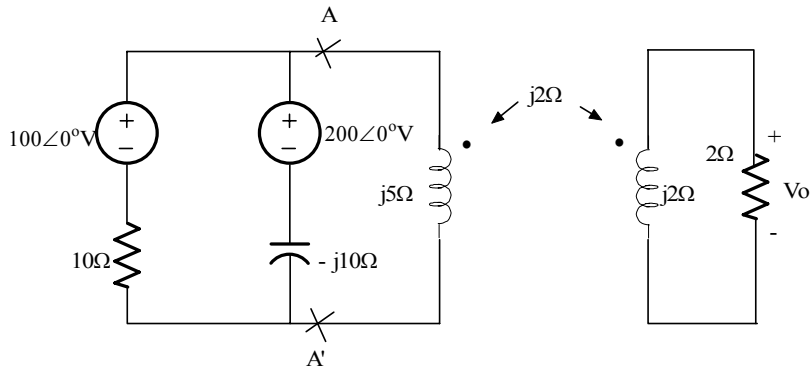

Figure P8.25

Suggested Solution



$$I = (100 - 200) / (10 - j10) = 7.07 \angle -135^\circ \text{A}$$

$$V_{oc} = 200 - j10 I = 150 + j50 \text{ V}$$

$$Z_{th} = 10 \parallel (-j10) = 5 - j5 \Omega$$

New circuit

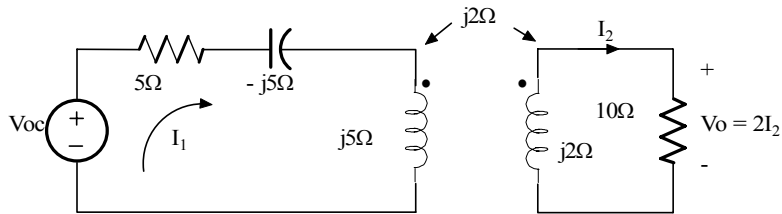

$$V_{oc} = I_1 (5 - j5 + j5) - j2 I_2 \quad (1)$$

$$0 = -j2 I_1 + I_2 (2 + j2) \quad (2)$$

Solve (2) for I_1 and substitute into (1) to get I_2

$$I_1 = I_2 (1 - j1)$$

$$V_{oc} = [(1 - j1)5 - j2] I_2 = (5 - j7) I_2$$

$$I_2 = (150 + j50) / (5 - j7) = 18.38 \angle 72.90^\circ \text{A}$$

$$V_o = 2 I_2 = 36.76 \angle 72.90^\circ \text{V}$$

Problem 8.26

Find V_o in the network in Figure P8.26

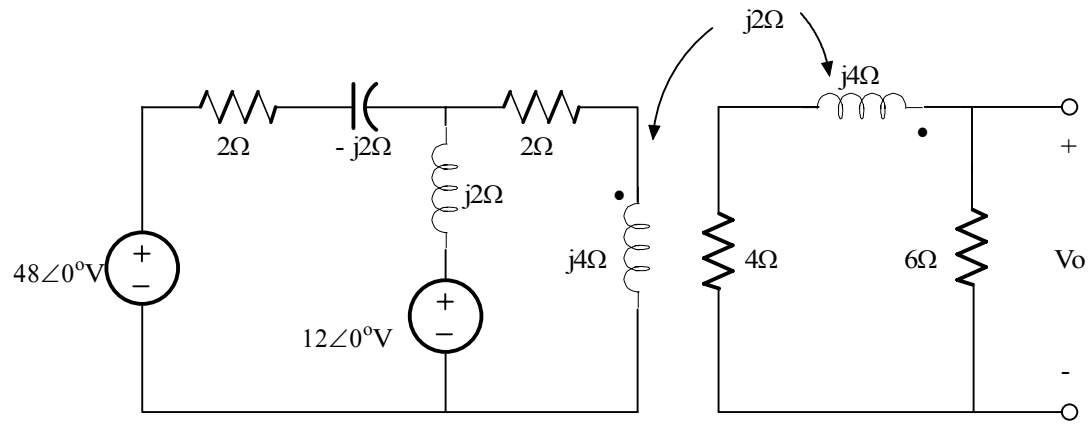
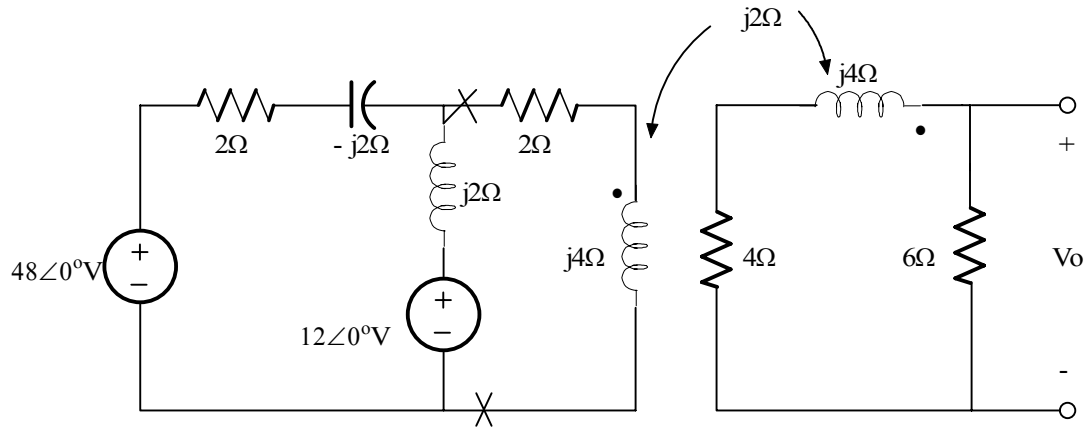

Figure P8.26

Suggested Solution



Thevenin equivalent at the input

$$V_{oc} = [(48 - 12) / (2 - j2 + j2)] (j2 + 12) = 12 + j36$$

$$Z_{th} = (2 - j2)(j2) / 2 = 2 + j2$$

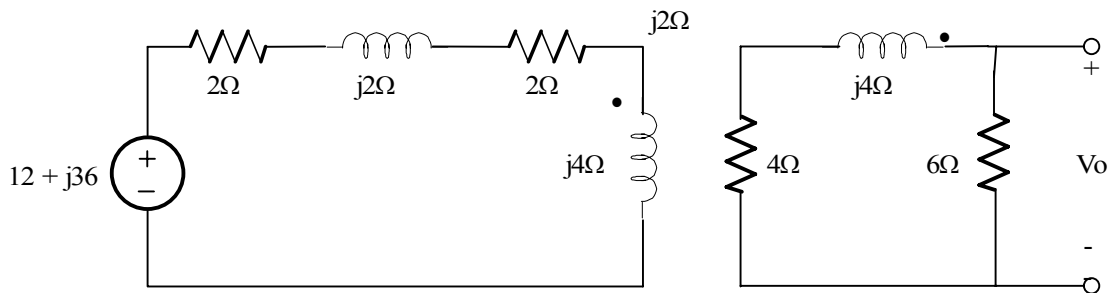

$$12 + j36 = (4 + j6)I_1 - j2 I_2$$

$$0 = -j2I_1 + (10 + j4)I_2$$

$$I_1 = [(10 + j4) / j2] I_2 = (2 - j5) I_2$$

$$12 + j36 = [(4 + j6)(2 - j5) - j2] I_2$$

$$I_2 = (12 + j36) / (38 - j10)$$

$$V_o = 6I_2 = 6 (12 + j36) / (38 - j10)$$

$$V = 5.79 \angle 86.31^\circ \text{V}$$

Problem 8.27

Find V_o in the network in Figure P8.27

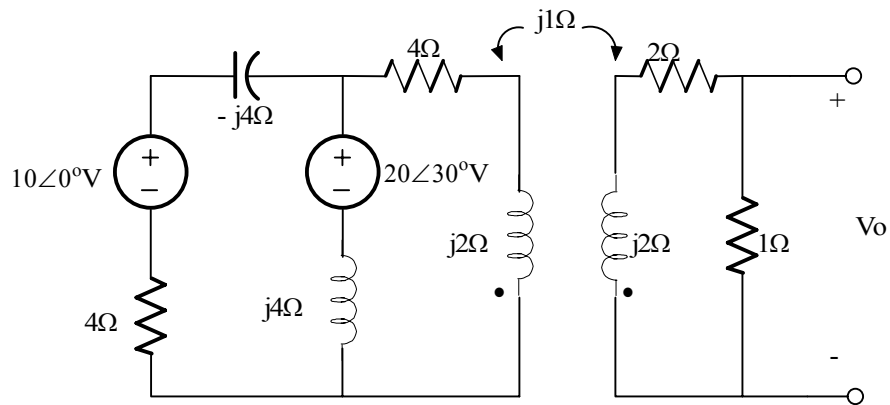
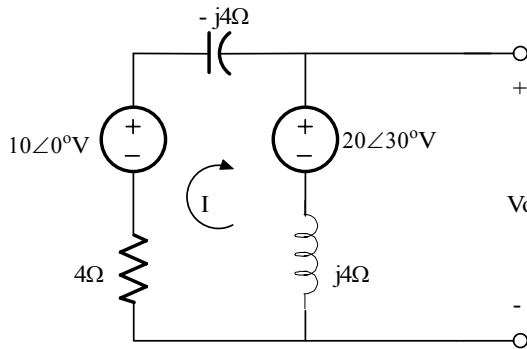

Figure P8.27

Suggested Solution

Thevenin Eq.



$$I = (10\angle 0^\circ - 20\angle 30^\circ) / 4 = 12.39/4 \angle -126.21^\circ$$

$$V_{oc} = 20\angle 30^\circ - j4I = 27.45\angle 5.60^\circ$$

$$Z_{th} = j4 \parallel (4 - j4) = 4 + j4 \Omega$$

New circuit

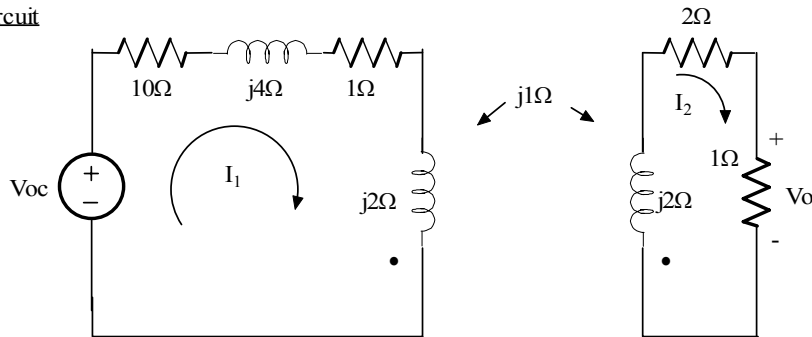

$$V_{oc} = I_1 (5 + j6) - j1 I_2 \quad \text{and} \quad 0 = (-j1)I_1 + I_2 (3 + j2) \quad (1) \text{ and } (2)$$

Solve (2) for I_1 , substitute into (1) to get I_2 and V_o

$$I_1 = I_2 (2 - j3) \Rightarrow V_{oc} = [(2 - j3)(5 + j6) - j1] I_2$$

$$I_2 = V_{oc} / (28 - j4) = 0.97\angle 13.73^\circ$$

$V_o = 0.97\angle 13.73^\circ \text{V}$

Problem 8.28

Find V_o in the network in Figure P8.28

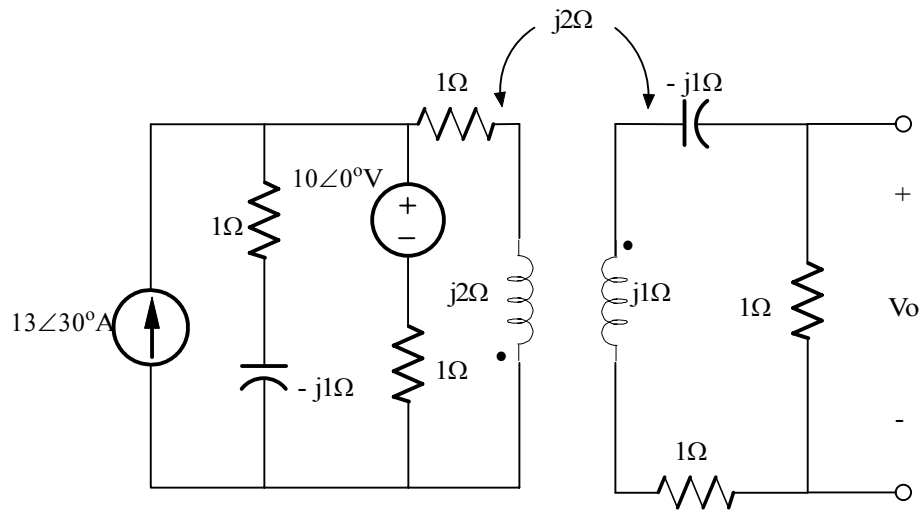
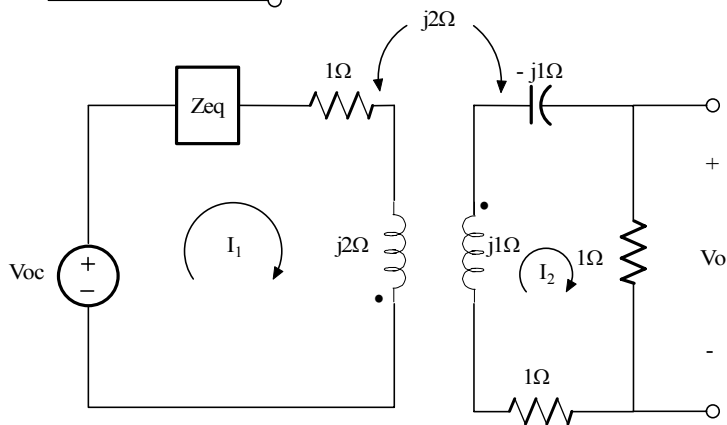
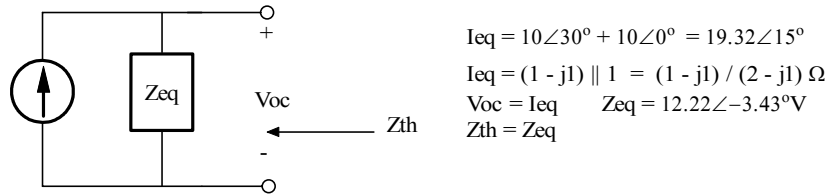
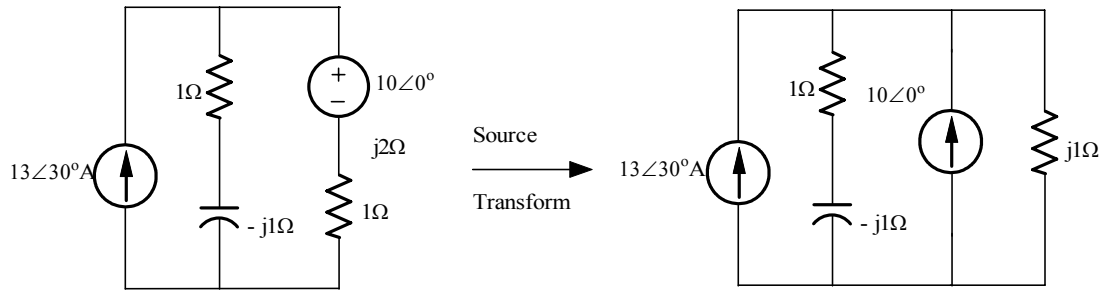

Figure P8.28

Suggested Solution



$$V_{oc} = I_1 (Z_{th} + 1 + j2) + j1 I_2 \quad \text{and} \quad 0 = j1 I_1 + 2I_2$$

$$I_1 = j2 I_2 \quad \text{and} \quad V_{oc} = [j2 (Z_{th} + 1 + j2) + j1] I_2$$

$$I_2 = [V_{oc} / (-3 + j12)] (2 - j1) \quad \text{and} \quad I_2 = 2.2\angle 134.1^\circ A \quad \text{and} \quad V_o = 2.21\angle -134.1^\circ V$$

$V_o = 2.21\angle -134.1^\circ V$

Problem 8.29

Find V_o in the network in Figure P8.29

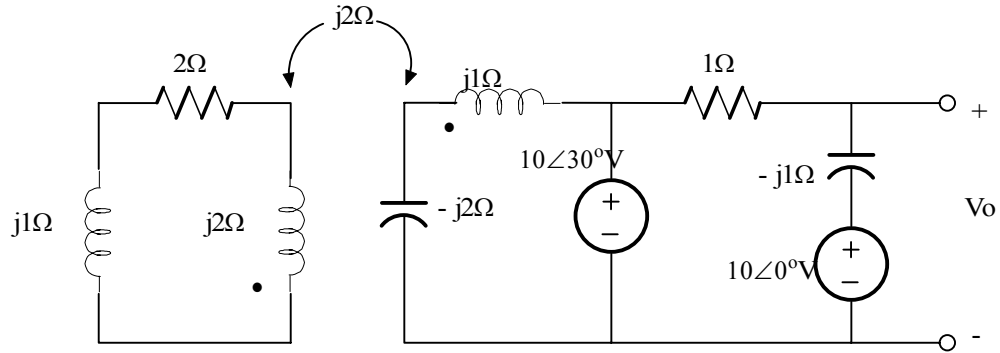
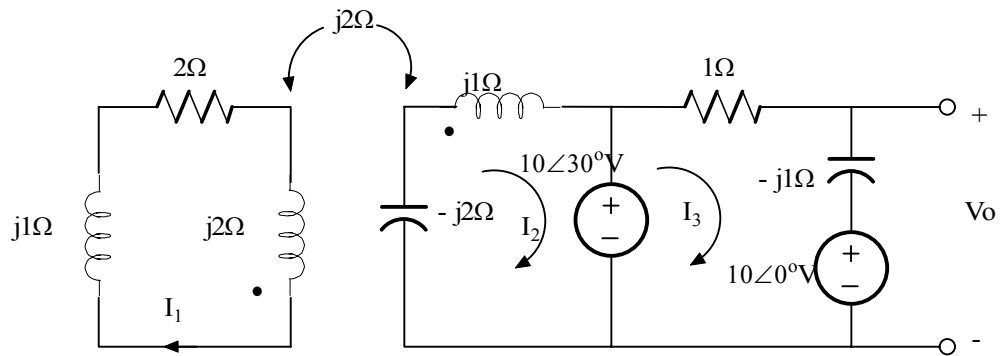

Figure P8.29

Suggested Solution



$$0 = I_1 (2 + j3) - j1 I_2 \quad (1)$$

$$-10\angle 30^\circ = -j1 I_1 + I_2(-j1) \quad (2)$$

$$10\angle 30^\circ - 10\angle 0^\circ = I_3 (1 - j1) \quad (3)$$

$$V_o = (-j1)I_3 + 10\angle 0^\circ \quad (4)$$

From (3) and (4)

we see that

V_o is independent of I_1 and I_2 !

$$\text{From (3), } I_3 = (10\angle 30^\circ - 10\angle 0^\circ) / ((\sqrt{2})\angle -45^\circ) = 3.66\angle 150^\circ \text{ A}$$

$$\text{From (4), } V_o = 3.66\angle 60^\circ - 10\angle 0^\circ$$

$V_o = 8.76\angle 158.80^\circ \text{V}$

Problem 8.30

Find I_o in the circuit in Figure P8.30

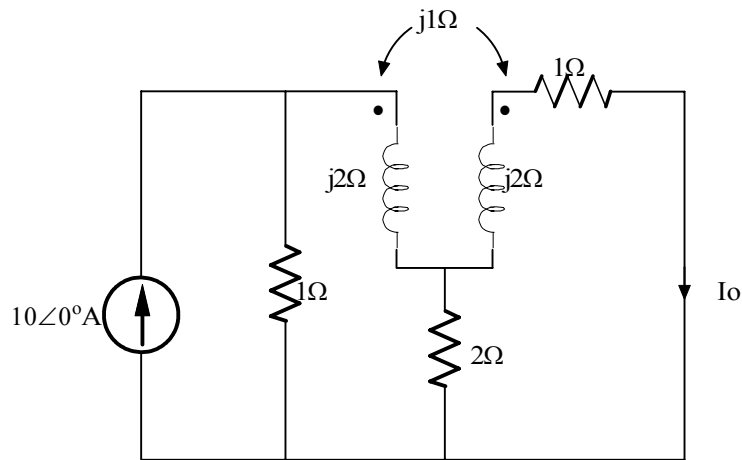
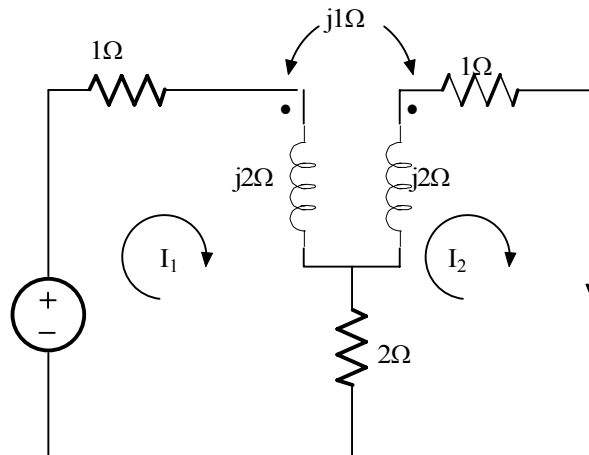

Figure P8.30

Suggested Solution



$$10 = I_1(3 - j2) - j1I_2 - 2I_2 \quad (1)$$

$$0 = I_2(3 + j2) - j1I_1 - 2I_1 \quad (2)$$

Solve (2) for I_1

$$I_1 = I_2(3 + j2) / (2 + j1) \quad (3)$$

Substitute (3) into (1) to find I_2

$$10 = [(3 + j2)(3 + j2) / (2 + j1) - 2 - j1] I_2 = I_2 [(9 - 4 + j12 - (2 + j1)(2 + j1)) / (2 + j1)]$$

$$I_2 = I_o = 10(2 + j1) / (2 + j8)$$

$$I_2 = I_o = 2.71 \angle -49.40^\circ \text{ A}$$

Problem 8.31

Find V_o in the circuit in Figure P8.31

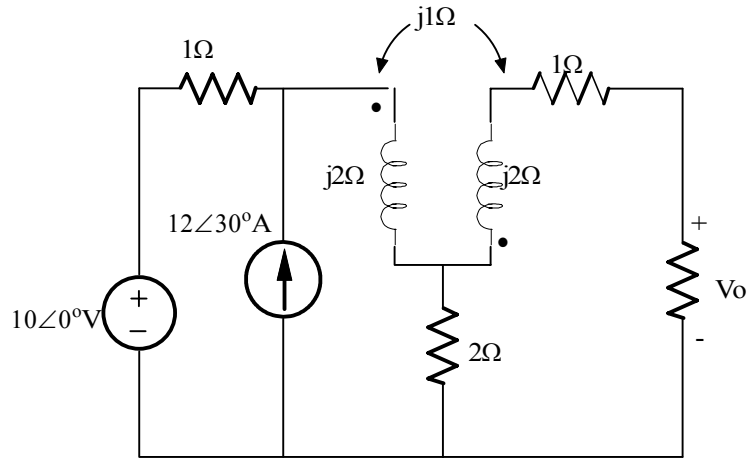
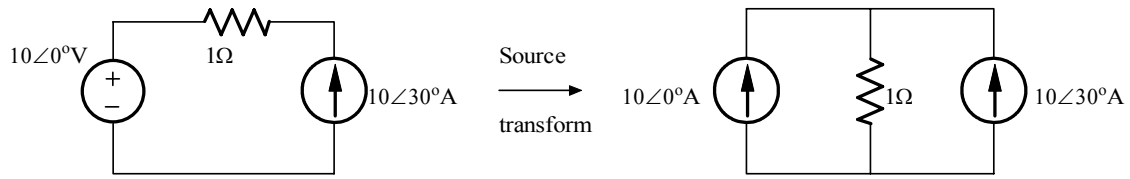

Figure P8.31

Suggested Solution

Try to simplify the left side of the circuit



Add current sources

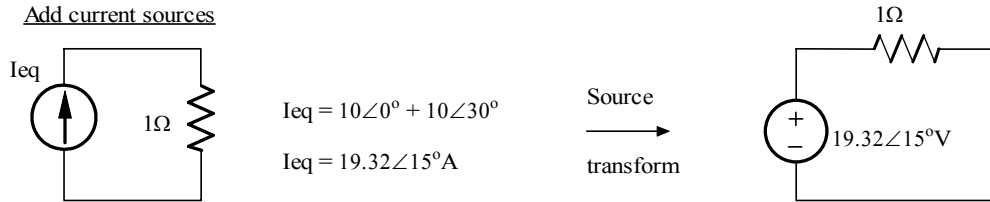

New Circuit

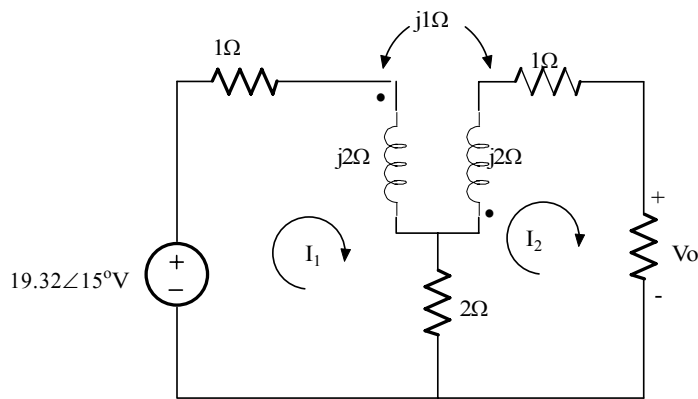

$$V_s = I_1 (2 + j2) + j1 I_2 - I_2 \quad (1)$$

$$0 = j1 I_1 - I_1 + I_2 (3 + 1) \quad (2)$$

Solve (2) for I_1 , substitute into (1) to get I_2 and V_o

$$I_1 = I_2 (3 + j1) / (1 - j1) \Rightarrow V_s = [(2 + j2)(3 + j1) / (1 - j1) + j1 - 1] I_2$$

$$V_s = I_2 [j2(3 + j1) + j1 - 1] = I_2 [-3 + j7]$$

$$I_2 = 2.54 \angle -98.20^\circ \text{ A}$$

Problem 8.32

Find I_o in the circuit in Figure P8.32

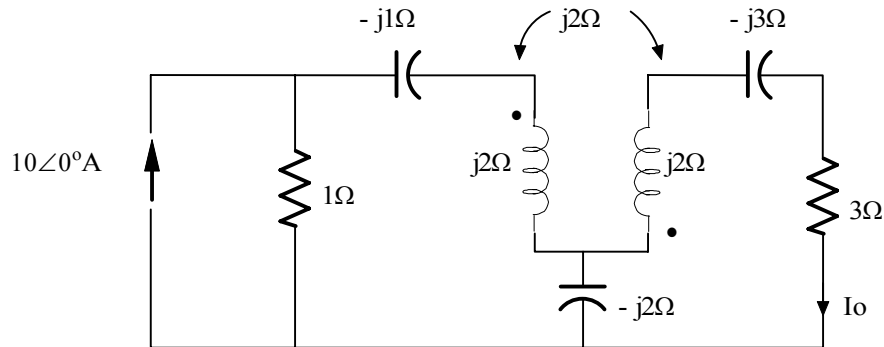
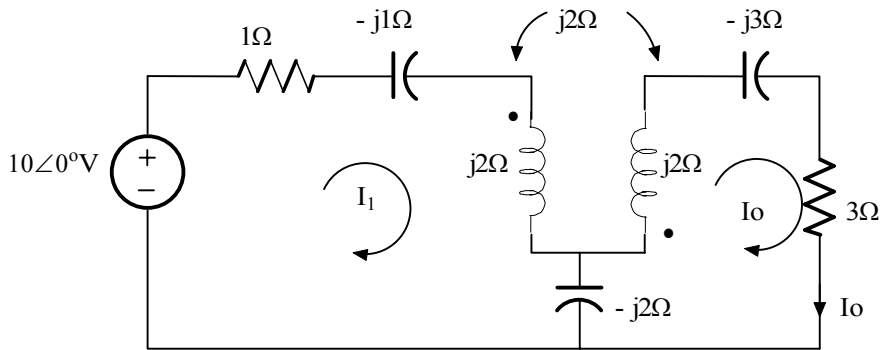

Figure P8.32

Suggested Solution



$$10 = I_1 (1 - j1) + I_o (j2 + j1) \quad (1)$$

$$0 = I_1 (j2 + j1) + I_o (3 - j3) \quad (2)$$

Solve (2) for I_o substitute into (1) to get I_o

$$I_1 = I_o (1 + j1) \Rightarrow 10 = I_o [(1 - j1)(1 + j1) + j3] = I_o (2 + j3)$$

$$I_o = 10 / (2 + j3)$$

$$I_o = 2.78 \angle -56.31^\circ \text{A}$$

Problem 8.33

Find V_o in the network in Figure P8.33

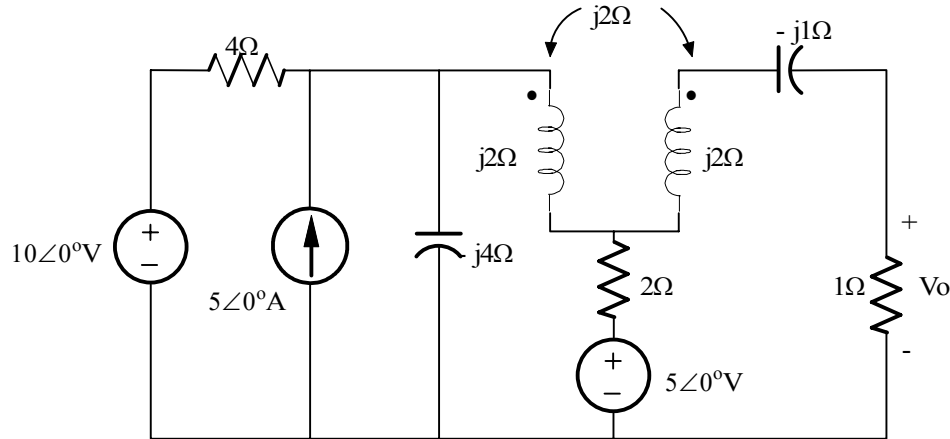
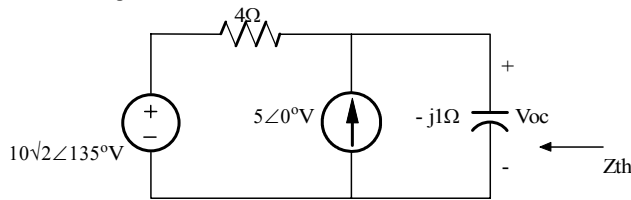

Figure P8.33

Suggested Solution

Thevenin Eq. of left-side of circuit



By superposition:

$$V_{oc} = 10\sqrt{2}\angle 135^\circ [-j4 / (4 - j4)] + 5 [4 \parallel -j4]$$

$$V_{oc} = 10\angle 0^\circ \text{V}$$

$$Z_{th} = 4 \parallel -j4 = 2 - j2\Omega$$

New circuit

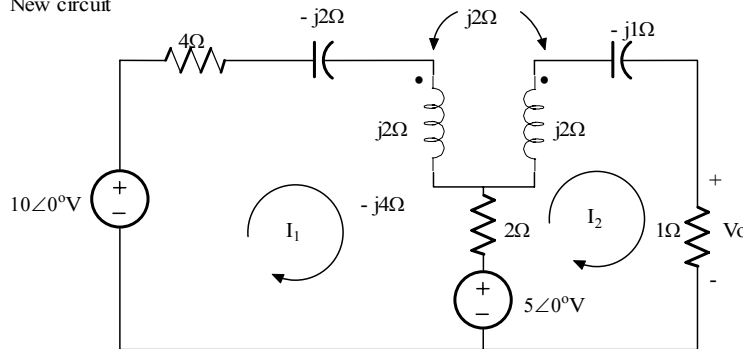

$$5 = I_1 (4) - I_2 (j2 + 2) \quad (1)$$

$$5 = -I_1 (2 + j2) + I_2 (3 + j1) \quad (2)$$

Solve (1) for I_1 , substitute into (2) to get I_2 and V_o

$$I_1 = [5 + I_2 (2 + j2)] / 4 \Rightarrow 5 = I_2 [(3 + j1) - (2 + j2)(2 + j2) / 4] - (2 + j2)(5/4)$$

$$I_2 (3 - j1) = 7.5 + j2.5 \Rightarrow I_2 = (7.5 + j2.5) / (3 - j1) = 2.5\angle 36.87^\circ \text{A}$$

$$V_o = (1) I_2 = 2.5\angle 36.87^\circ \text{V}$$

Problem 8.34

Find V_o in the network in Figure P8.34

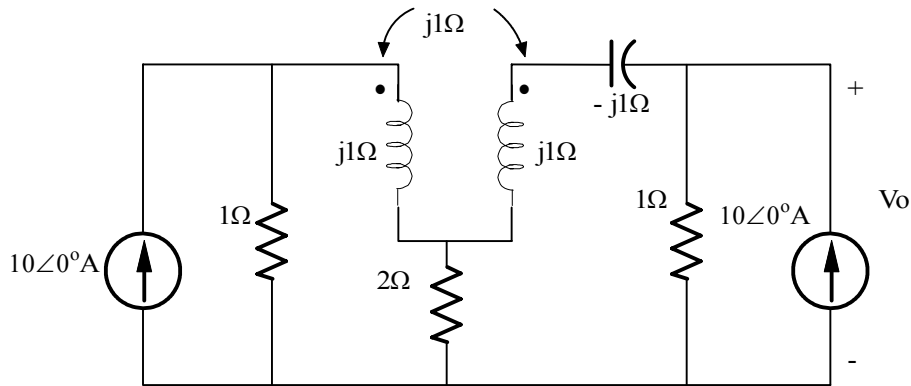
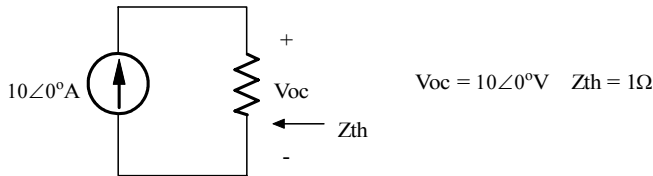

Figure P8.34

Suggested Solution

Thevenin eq. for left and right side of circuit



New circuit

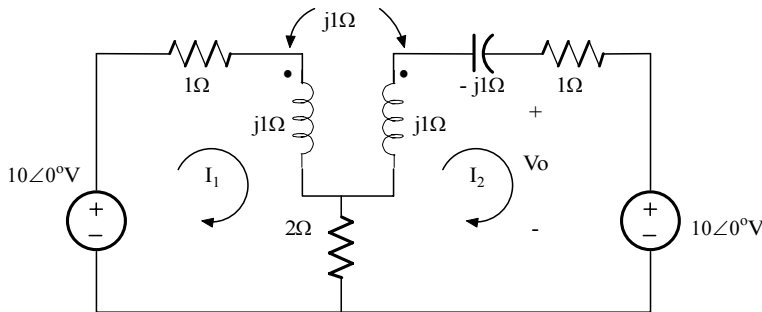

$$10 = I_1(3 + j1) - I_2(2 + j1) \quad (1)$$

$$-10 = -I_1(2 + j1) + I_2(3) \quad (2)$$

solve (2) for I_1

$$I_1 = (10 + 3I_2) / (j1 + 2)$$

$$10 = (10 + 3I_2)[(3 + j1) / (2 + j1)] - I_2(2 + j1) = 10[(3 + j1) / (2 + j1)] + I_2(6 - j1) / (2 + j1)$$

$$I_2 = [10(2 + j1) - 10(3 + j1)] / (6 - j1) = 1.64\angle -170.54^\circ \text{A}$$

$$V_o = (1)I_2 + 10 = 8.38\angle -1.85^\circ \text{V}$$

Problem 8.35

Determine the impedance seen by the source in the network shown in Figure P8.35

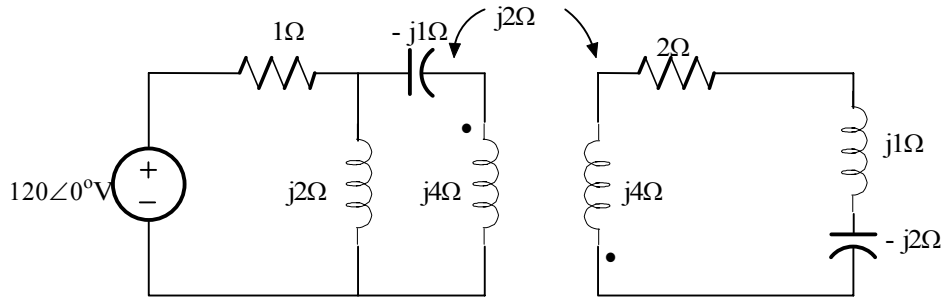
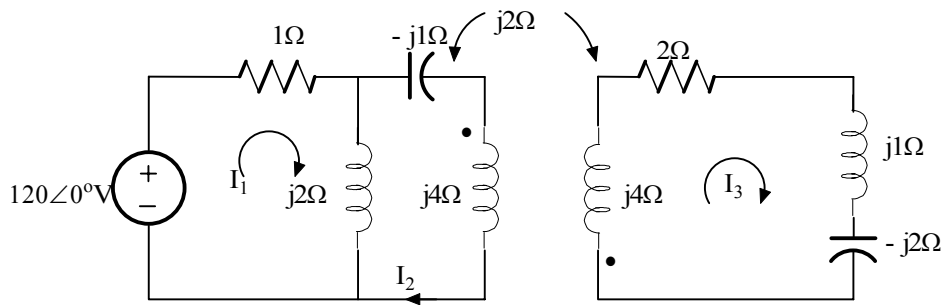

Figure P8.35

Suggested Solution



$$120 = I_1(1 + j2) - j2I_2 \quad ; \quad 0 = -j2I_1 + j5I_2 + j2I_3 \quad ; \quad 0 = j2I_2 + I_3(2 + j3) \quad (1) \ (2) \ \text{and} \ (3)$$

solve (3) for I_2 and substitute into (1) and (2)

$$I_2 = I_3(-3/2 + j1) \Rightarrow 120 = I_1(1 + j2) + I_3(2 + j3); \quad 0 = -j2I_1 + I_3(-5 - j1/2) \quad (4) \ \text{and} \ (5)$$

Solve (5) for I_3 and substitute into (4)

$$I_3 = +j2I_1 / (-5 - j1/2) = -j4I_1 / (10 + j11)$$

$$120 = I_1 [1 + j2 + (2 + j3)(-j4) / (10 + j11)] = I_1 [(10 + j11)(1 + j2) + 12 - j8] / (10 + j11)$$

$$120 = I_1 [1 + j2 + (2 + j3)(-j4) / (10 + j11)] = I_1 [(10 + j11)(1 + j2) + 12 - j8] / (10 + j11)$$

$$Z_{\text{source}} = 120 / I_1 = (10 - 22 + j11 + j20 + 12 - j8) / (10 + j11) = (j23) / (10 + j11)$$

$Z_{\text{source}} = 1.56 \angle 42.27^\circ \Omega$

Problem 8.36

Determine the impedance seen by the source in the network shown in Figure P8.36

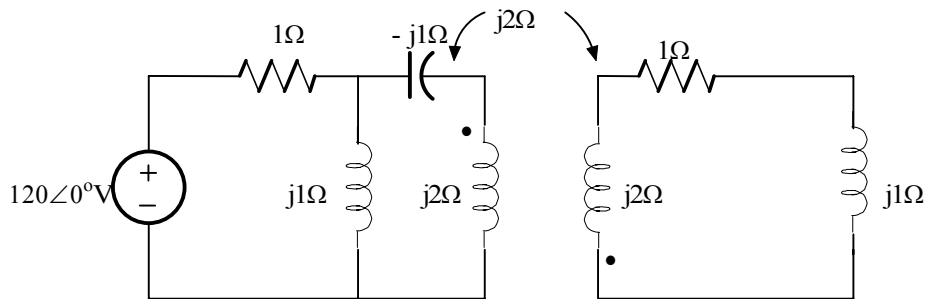
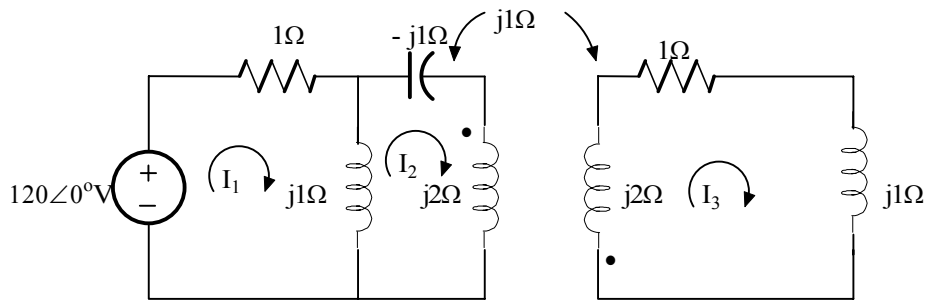

Figure P8.36

Suggested Solution



$$120 = I_1 (1 + j1) - j1 I_2 ; 0 = -j1 I_1 + j2 I_2 - j1 I_3 ; 0 = j1 I_2 + I_3 (1 + j3) \quad (1) \text{ (2) and (3)}$$

solve (3) for I_2 and substitute into (1) and (2)

$$I_2 = I_3 (-3 - j1) \Rightarrow 120 = I_1 (1 + j1) + I_3 (-1 - j3); 0 = -j1 I_1 + I_3 (2 + j5) \quad (4) \text{ and (5)}$$

Solve (5) for I_3 and substitute into (4)

$$I_3 = +j1 I_1 / (2 + j5)$$

$$120 = I_1 [1 + j1 - (1 + j3)(j1) / (2 + j5)] = I_1 [j6 / (2 + j5)]$$

$$Z_{\text{source}} = 120 / I_1 = (j6) / (2 + j5)$$

$Z_{\text{source}} = 1.11 \angle 21.8^\circ \Omega$

Problem 8.37

Determine the input impedance Z_{in} of the circuit in Figure P8.37

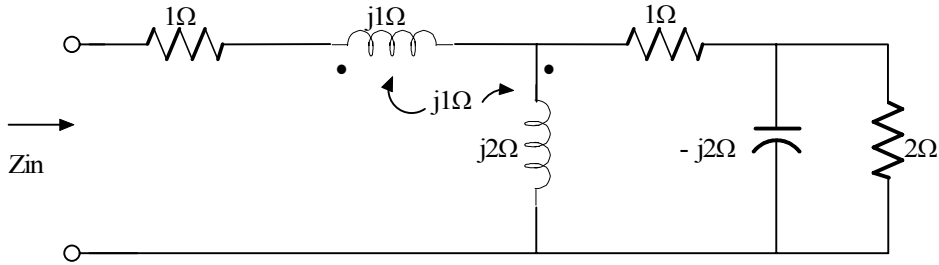
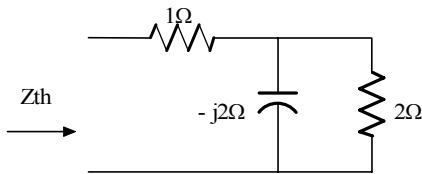

Figure P8.37

Suggested Solution

Thevenin's eq. at right side of circuit



$$Z_{th} = 1 + (2 \parallel -j2) = 1 - (j4) / (2 - j2) = 1 + 1 - j1 = 2 - j1 \Omega$$

New circuit

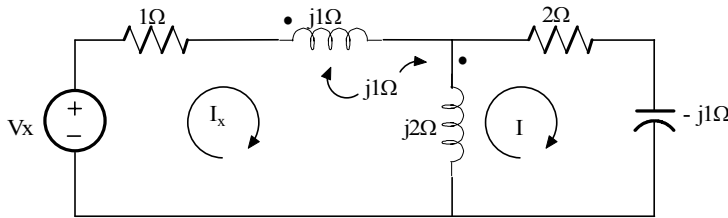

$$\begin{aligned} V_x &= I_x (1 + j3) - j2I + j1I_x + j1(I_x - I) \\ 0 &= I (2 + j1) - j2I_x - j1I_x \end{aligned}$$

Solve (2) for I and substitute into (1)

$$I = j3I_x / (2 + j1) \Rightarrow V_x = I_x [(1 + j3 + 2) (-j3)(j3) / (2 + j1)]$$

$$V_x = I_x [1 + j5 + (9) / (2 + j1)] = [(2 + j10 + j1 - 5 + 9) / (2 + j1)] I_x = (6 + j11) / (2 + j1) I_x$$

$$Z_{in} = V_x / I_x = (6 + j11) / (2 + j1)$$

$Z_{in} = 5.60 \angle 34.820^\circ \Omega$

Problem 8.38

Determine the input impedance Z_{in} in the network in Figure P8.38

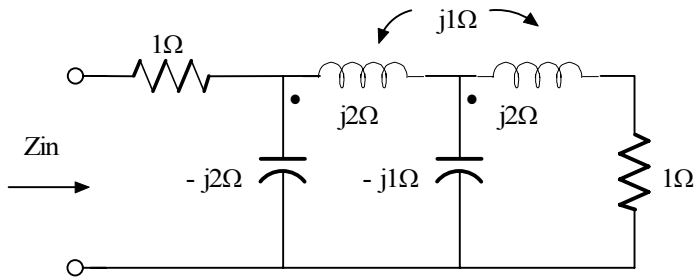
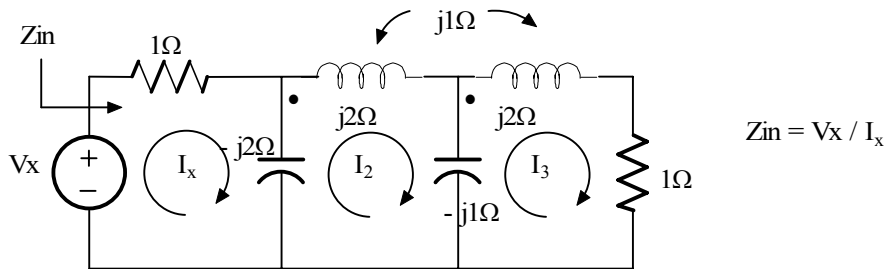

Figure P8.38

Suggested Solution



$$Z_{in} = V_x / I_x$$

$$V_x = I_x (1 - j2) + j2 I_2 ; 0 = j2I_x - j1I_2 + j2 I_3 ; 0 = j2I_2 + I_3(1 + j1) \quad (1) (2) \text{ and } (3)$$

solve (3) for I_2 and substitute into (1) and (2)

$$I_2 = I_3(-1 + j1) / 2 \Rightarrow V_x = I_x (1 - j2) + I_3(-1 - j1); 0 = j2I_x + I_3(1/2 + 5/2 j) \quad (4) \text{ and } (5)$$

Solve (5) for I_3 and substitute into (4)

$$I_3 = +j4I_x / (1 + j5) \Rightarrow V_x = I_x [1 - j2 + (1 + j1)(j4)/(1 + j5)]$$

$$Z_{in} = V_x / I_x = [(1 - j2)(1 + j5) - 4 + j4] / (1 + j5) = (7 + j7) / (1 + j5)$$

$Z_{in} = 1.94 \angle -33.69^\circ \Omega$

Problem 8.39

Given the network shown in Figure P8.39 determine the value of the capacitor C that will cause the impedance seen by the $24\angle 0^\circ$ V voltage source to be purely resistive. $f = 60\text{Hz}$.

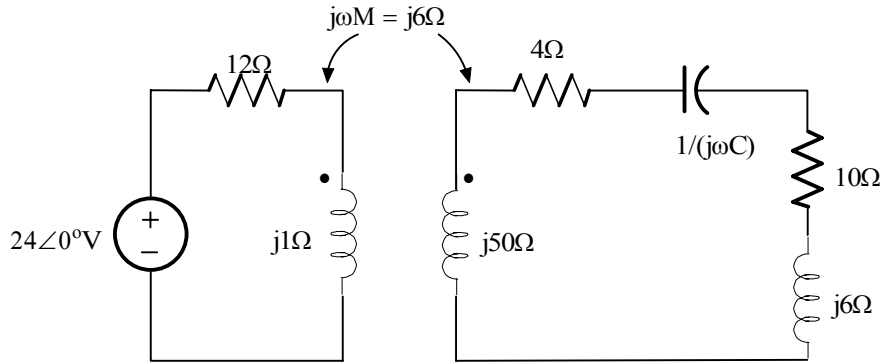
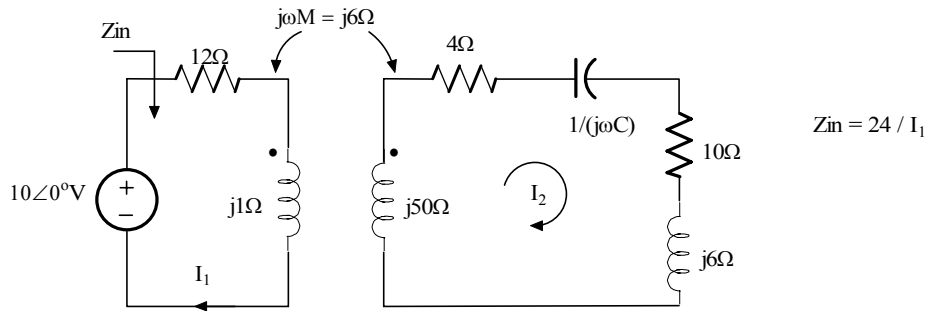

Figure P8.39

Suggested Solution



$$24 = I_1(12 + j1) - j6 I_2 \quad \text{and} \quad 0 = -j6 I_1 + I_2(14 + j(56 - X_c)) \quad (1) \text{ and } (2)$$

Solve (2) for I_2 and substitute into (1)

$$I_2 = j6 I_1 / [14 + j(56 - X_c)] \Rightarrow 24 = I_1 [12 + j1 + 36 / (14 + j(56 - X_c))]$$

$$Z_{in} = 24 / I_1 = 12 + j1 + 36 / [14 + j(56 - X_c)] = R_{in} + j0$$

Thus,

$$36 / [14 + j(56 - X_c)] = R - j1 \quad \text{where} \quad R_{in} = 12 + R$$

$$36 = 14R + 56 - X_c \quad \text{and} \quad 0 = R(56 - X_c) - 14 \quad (3) \text{ and } (4)$$

Solve (3) for X_c , substitute into (4) to find R

$$X_c = 14R + 20 \Rightarrow 0 = R(56 - 14R - 20) - 14 \Rightarrow 14R^2 - 36R + 14 = 0$$

$R = \{2.094\Omega, 0.478\Omega\} \quad X_c = \{49.316\Omega, 26.692\Omega\} \quad C = \{53.79\mu\text{F}, 99.38\mu\text{F}\} \quad R_{in} = \{14.09\Omega, 14.48\Omega\}$
--

Problem 8.40

Analyze the network in Figure P8.40 and determine if a value of X_c can be found such that the output voltage is equal to twice the input voltage.

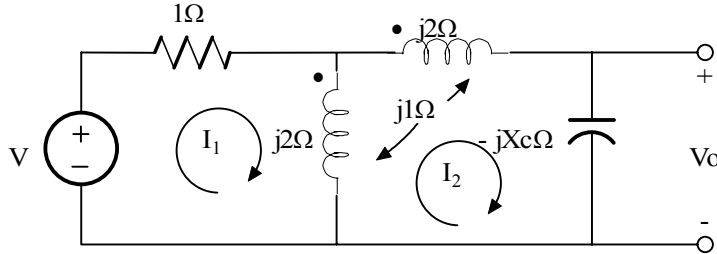
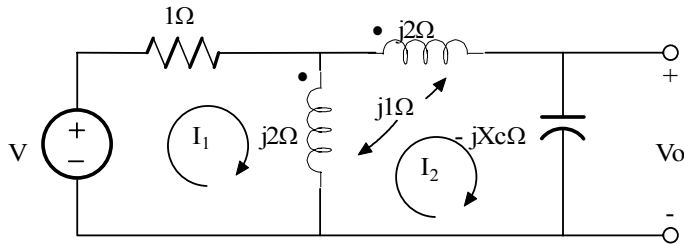

Figure P8.40

Suggested Solution



$$V_o = I_2 (-j X_c)$$

$$V = I_1 (1 + j2) - j2 I_2 + j1 I_2$$

$$0 = -j2I_1 + I_2(j4 - jX_c) + j1 (I_1 - I_2)$$

$$(j1)I_1 = I_2 j(3 - X_c) \Rightarrow V = I_2[(3 - X_c)(1 + j2) - j1]$$

$$\text{But } I_2 = V_o / (-jX_c) \text{ so } V = [V_o / (-jX_c)] (3 + j6 - X_c - j2X_c - j1)$$

$$\text{And } V_o/V = (-jX_c) / (3 - X_c + j(5 - 2X_c)) = X_c / [-5 + 2X_c + j(3 - X_c)]$$

For no phase shift between V_o and V

Then

$$3 - X_c = 0 \Rightarrow X_c = 3\Omega$$

$$V_o / V = X_c / (-5 + 2X_c) = 3 / (-5 + 6) = 3$$

No value of X_c exists such that $V_o = 2V$

If we allow phase shift, then,

$$|V_o/V| = 2 = X_c / \sqrt{(-5 + 2X_c)^2 + (3 - X_c)^2} \Rightarrow 4(34 - 26X_c + 5X_c^2) = X_c^2$$

$$19X_c^2 - 104X_c + 136 = 0 \text{ and } X_c = 3.31\Omega \text{ and } 2.14\Omega$$

There are 2 values of X_c for $|V_o/V| = 2$

$$V_o/V = (3.31) / (1.62 - 0.31j) = 2 \angle 10.8^\circ \text{ and } V_o/V = (2.161) / (-0.678 + j0.839) = 2 \angle 128.9^\circ$$

Problem 8.41

Two coils in a network are positioned such that there is 100% coupling between them. If the inductance of one coil is 10 mH and the mutual inductance is 6mH, compute the inductance of the other coil

Suggested Solution

$$k = \frac{M}{\sqrt{L_1 L_2}} \quad k = 1, M = 6mH, L_1 = 10mH$$

$$L_2 = \frac{1}{L_1} \left(\frac{M}{k}\right)^2 = \boxed{3.6mH}$$

Problem 8.42

The currents in the magnetically coupled inductors shown in Figure P8.42 are known to be $i_1(t) = 8\cos(377t - 20^\circ)\text{mA}$ and $i_2(t) = 4\cos(377t - 50^\circ)\text{mA}$. The inductor values are $L_1 = 2\text{H}$, $L_2 = 1\text{H}$, and $k = 0.6$. Determine $v_1(t)$ and $v_2(t)$.

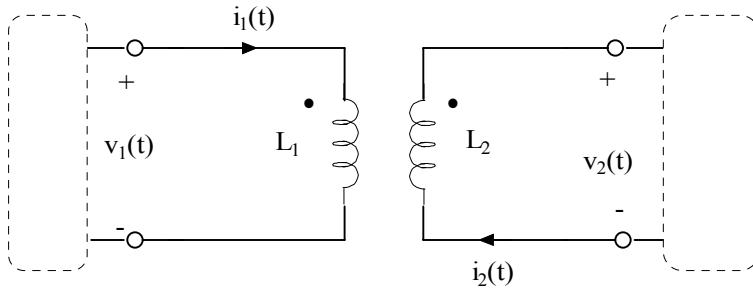

Figure P8.42

Suggested Solution

For the coupled inductors,

$$i_1(t) = 8\cos(377t - 20^\circ)\text{mA, and}$$

$$i_2(t) = 4\cos(377t - 50^\circ)\text{mA, } L_1 = 2$$

$$L_2 = 1, K = 0.6, \text{ and } v_1(t), v_2(t).$$

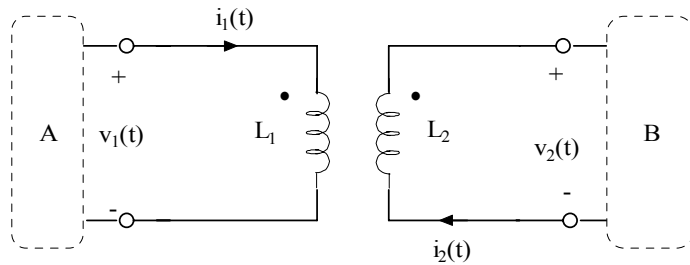

$$\text{Mutual coupling } M = 0.6\sqrt{2 \cdot 1} = 0.85$$

Then

$$v_1(t) = \frac{L_1 di_1(t)}{dt} - M \frac{di_2(t)}{dt}$$

$$v_1(t) = 2 \frac{d}{dt} (8\cos(377t - 20^\circ)) - 0.85 \frac{d}{dt} (4\cos(377t - 50^\circ))\text{mA}$$

$$\boxed{v_1(t) = -6\sin(377t - 20^\circ) + 1.3\sin(377t - 50^\circ)}$$

$$v_2(t) = \frac{-L_2 di_2(t)}{dt} + M \frac{di_1(t)}{dt}$$

$$\boxed{v_2(t) = 1.6\sin(377t - 50^\circ) - 2.6\sin(377t - 20^\circ)}$$

Problem 8.43

Determine the energy stored in the coupled inductors in Problem 8.42 at $t=1\text{ms}$

Suggested Solution

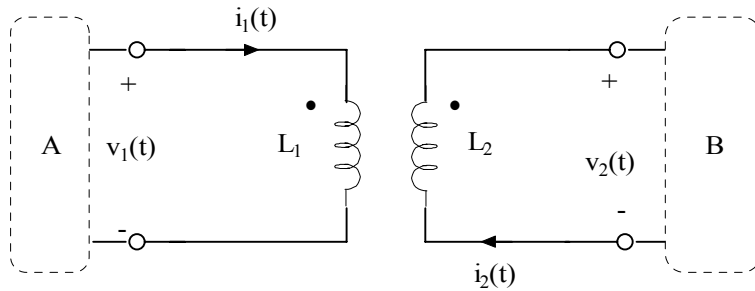

Find energy stored in inductors of P8.42 at $t=1\text{ms}$

$$\text{At } t = 1\text{ms}, \omega t = (377)(0.001) = 0.337\text{rad} = 21.6^\circ$$

$$\text{then, } i_1(t=0.001) = 8\cos(21.6^\circ - 20^\circ) = 8.0 \text{ mA}$$

$$i_2(t=0.001) = 4\cos(21.6^\circ - 50^\circ) = 3.52\text{mA}$$

$$\text{and } \omega(t=0.001) = \frac{1}{2} (2) (2\text{mA})^2 + \frac{1}{2} (1)(3.52\text{mA})^2 - 0.85(8)(3.53\text{mA})^2$$

$$\omega(t=0.001) = 46.3 \mu\text{J}$$

Problem 8.44

If $L_1 = L_2 = 4\text{H}$ and $k = 0.8$, find $i_1(t)$ and $i_2(t)$ in the circuit in Figure P8.44

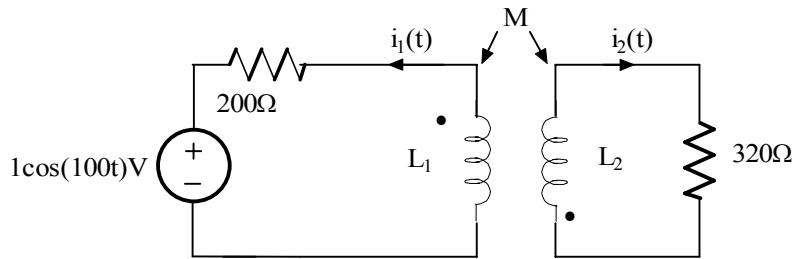
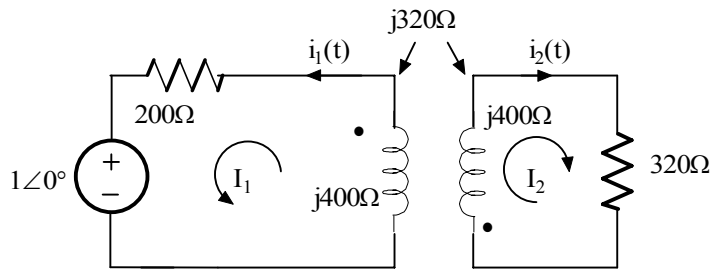

Figure P8.44

Suggested Solution

Convert to frequency domain!

$$1 \cos(100t) \rightarrow 1 \angle 0^\circ ; i_1(t) \rightarrow I_1 ; i_2(t) \rightarrow I_2 \quad M = k (L_1 L_2)^{1/2} = 3.2\text{H}$$



$$1 \angle 0^\circ = -I_1 (200 + j400) + j320 I_2 \quad \text{and} \quad 0 = I_2(320 + j400) - j320 I_1$$

$$1 \angle 0^\circ = [(-1.25 + j1)(200 + j400) + j320] I_2 \quad I_1 = I_2 (1.25 - j1)$$

$$I_2 = 1 / (-650 + j20) = 1.54 \angle -178.24^\circ \text{ mA}$$

$$I_1 = I_2 (1.25 - j1) = I_2 (1.60 \angle -38.66^\circ) = 2.46 \angle 143.10^\circ \text{ mA}$$

$$i_2(t) = 1.54 \cos(100t - 178.24^\circ) \text{ mA}$$

$$i_1(t) = 2.46 \cos(100t + 143.10^\circ) \text{ mA}$$

Problem 8.45

Determine the energy stored in the coupled inductors in the network in P8.44

Suggested Solution

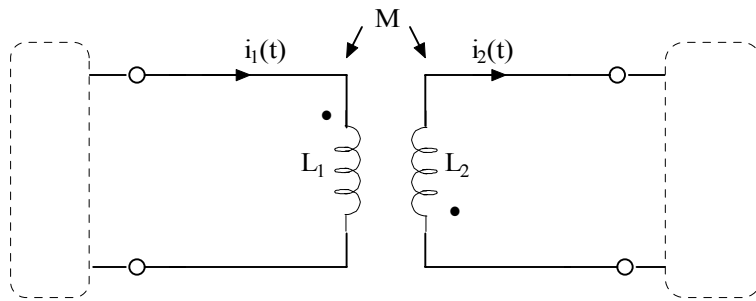

$$L_1 = L_2 = 4\text{H} \quad k = 0.8$$

$$M = 3.2\text{H}$$

From problem 11.32, $i_1(t)$ and $i_2(t)$ as defined here are

$$i_1(t) = -2.46 \cos(100t + 143.10) \text{ mA}$$

$$i_2(t) = 1.54 \cos(100t - 178.24) \text{ mA}$$

$$w(t) = \frac{1}{2} L_1 i_1^2(t) + \frac{1}{2} L_2 i_2^2(t) + M i_1(t) i_2(t)$$

Evaluate at $t = 2\text{ms}$

$$w(0.002) = 3.71 \mu\text{J}$$

Problem 8.46

Find all currents and voltages in the network in figure P8.46

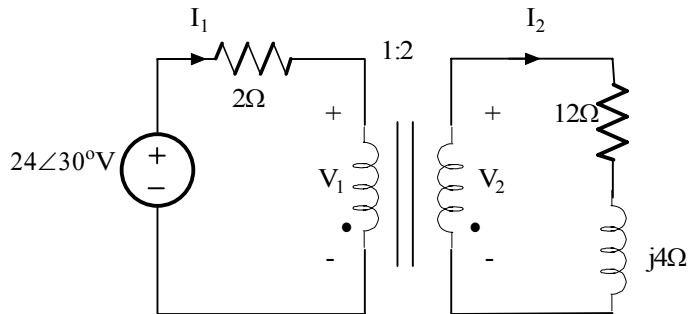

Figure P8.46

Suggested Solution

Find I_1 , I_2 , V_1 , V_2

For the secondary

$$Z = (12 + 4j) / (2^2) = 3 + j$$

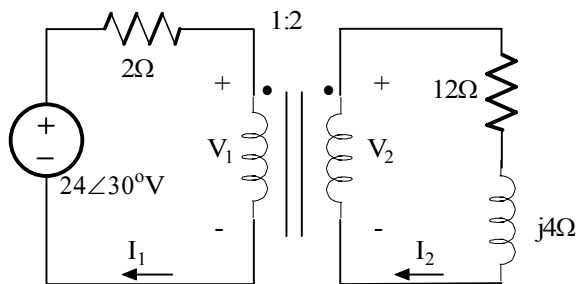

In the primary, $I_1 = (24\angle 30^\circ) / (2 + 3 + j) = \underline{4.7\angle 18.7^\circ \text{A}}$

Then $V_1 = I_1 Z_1 = (4.7\angle 18.7^\circ)(3.2\angle 18.4^\circ) = \underline{15\angle 37.1^\circ \text{V}}$

And $V_2 = 2V_1 = \underline{30\angle 32.1^\circ \text{V}}$, $I_2 = I_1/2 = \underline{2.35\angle 18.7^\circ \text{A}}$

Problem 8.47

Determine I_1 , I_2 , V_1 , and V_2 in the network in Figure P8.47

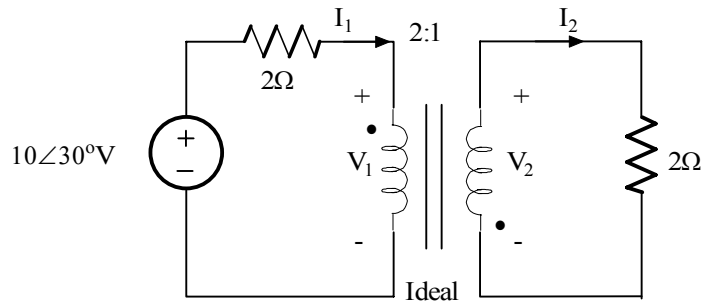
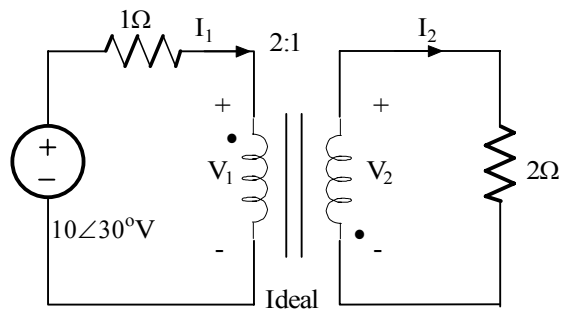

Figure P8.47

Suggested Solution



$$Z_L = 2\Omega, \quad n = 1/2, \quad Z_1 = Z_L/n^2 = 8\Omega$$

$$V_1 = 10\angle 30^\circ [Z_1 / (Z_1 + 1)] = 8.89\angle 30^\circ \text{V}$$

$$I_1 = (10\angle 30^\circ) / (1 + Z_1) = (10/9)\angle 30^\circ \text{A} = 1.11\angle 30^\circ \text{A}$$

$$I_2 = -I_1 / n = -2.22\angle 30^\circ \text{A} = 2.22\angle -150^\circ \text{A}$$

$$V_2 = -n V_1 = 4.44\angle -150^\circ \text{V}$$

Problem 8.48

Determine V_o in the circuit in Figure P8.48

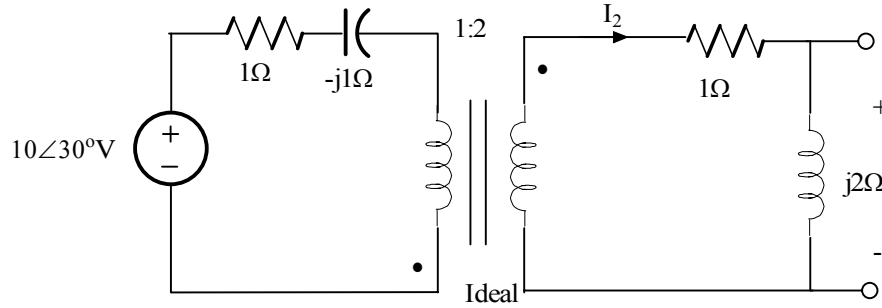
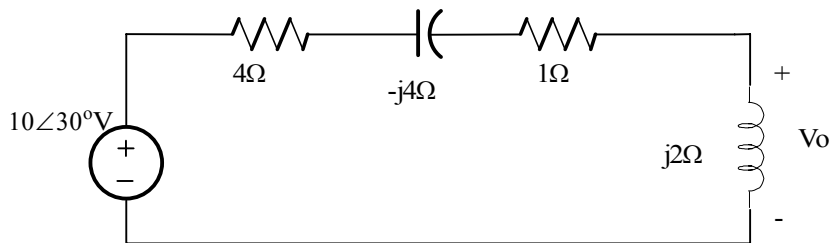
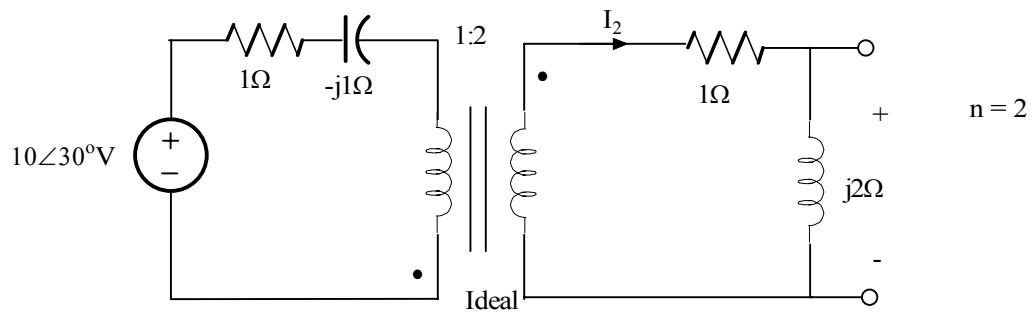

Figure P8.48

Suggested Solution



$$V_o = -20\angle 30^\circ [j2 / (5 - j2)]$$

$$V_o = 7.43\angle -38.20^\circ \text{V}$$

Problem 8.49

Determine I_1 , I_2 , V_1 in the network in Figure P8.49

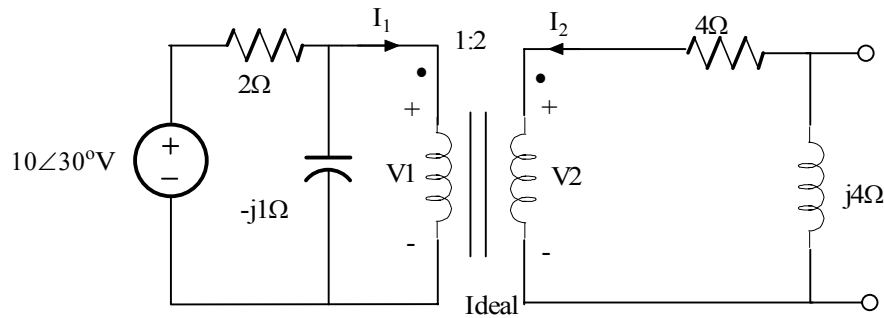
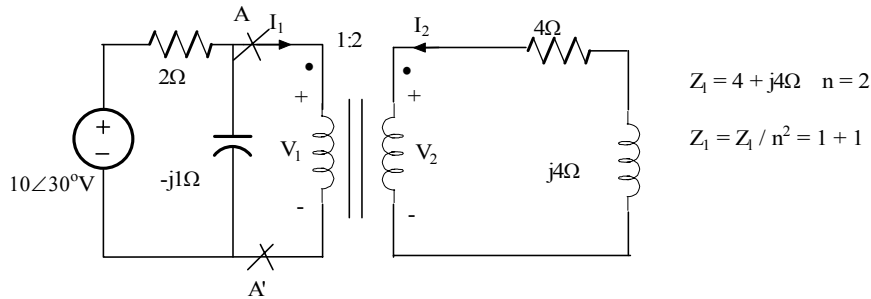
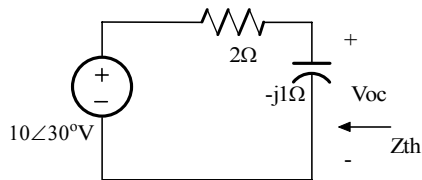

Figure P8.49

Suggested Solution



Thevenin Eq. at A-A'



$$V_{oc} = 10\angle 30^\circ [-j1 / (2 - j1)] = 4.47\angle -33.43^\circ \text{V}$$

$$Z_{th} = 2 \parallel (-j1\Omega) = (-j2) / (2 - j1) = 0.89\angle -63.43^\circ \Omega$$

New Circuit

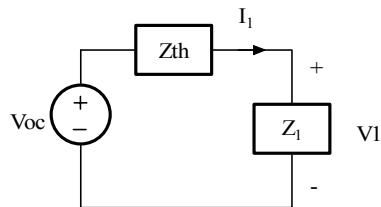

$$I_1 = V_{oc} / (Z_{th} + Z_1) = V_{oc} / (0.4 - j0.8 + 1 + j1) = V_{oc} / (1.4 + j0.2)$$

$$I_1 = 3.16\angle -41.56^\circ \text{A}$$

$$V_1 = I_1 Z_1 = 4.47\angle 3.44^\circ \text{V}$$

$$V_2 = n V_1 = 8.94\angle 3.44^\circ \text{V}$$

$$I_2 = -I_1 / n = 1.58\angle 138.44^\circ \text{A}$$

Problem 8.50

Determine I_1 , I_2 , and V_1 in the network in Figure P8.50

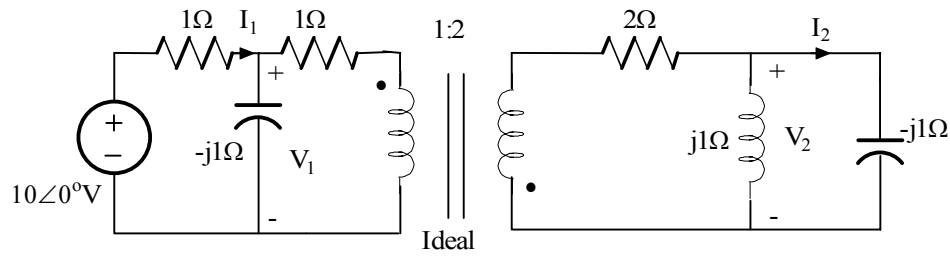
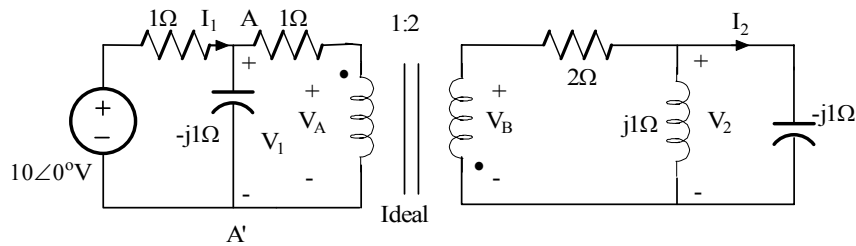

Figure P8.50

Suggested Solution



$$Z_L = 2 + (j1 \parallel (-j1)) = 2\Omega \quad n=2 \quad Z_A = Z_L/n^2 = 1/2\Omega$$

Thevenin equivalent at A - A'

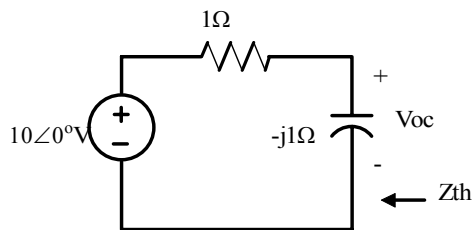

$$V_{oc} = 10[(-j1) / (1 - j1)] = 5 - j5 = 7.07\angle-45^\circ\text{V}$$

$$Z_{th} = 1 \parallel (-j1) = (-j1) / (1 - j1) = 1/2 - j1/2\Omega$$

New circuit

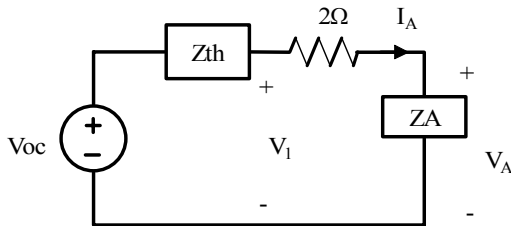

$$I_A = V_{oc} / (Z_{th} + 1 + Z_A) = 7.07\angle-45^\circ / (2 - 1/2j)$$

$$I_A = 3.43\angle-30.96^\circ\text{A}$$

$$V_1 = I_A(1 + Z_A) = 3/2 I_A = 5.15\angle-30.96^\circ\text{V}$$

$$I_1 = V_1 / (-j1) + I_A = 5.15\angle59.04^\circ + 3.43\angle-30.96^\circ = 6.19\angle25.380^\circ\text{A}$$

$$V_B = -nV_A = -2(I_A Z_A) = 3.43\angle-149.04^\circ\text{V}$$

$$I_B = -I_A / n = 1.72\angle149.04^\circ\text{A}$$

In the secondary since $j1 \parallel (-j1) = \infty$, $V_2 = V_B = 3.43\angle149.04^\circ\text{A}$

$$I_2 = V_2 / (-j1) = 3.43\angle-120.96^\circ\text{A}$$

Problem 8.51

Determine I_1 , I_2 , V_1 , and V_2 in the network in Figure P8.51

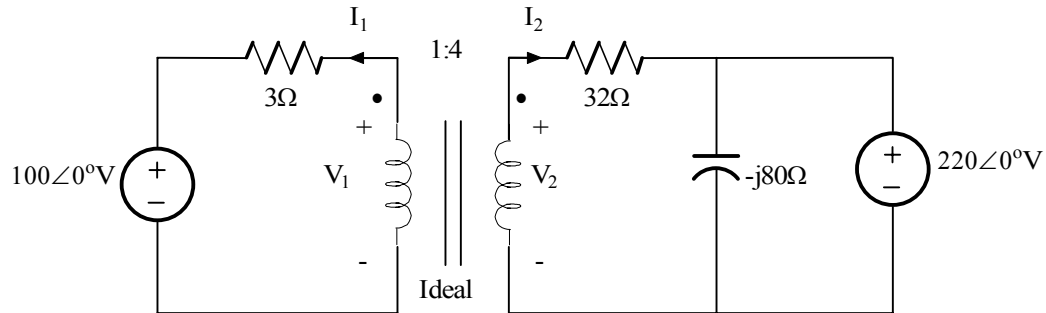
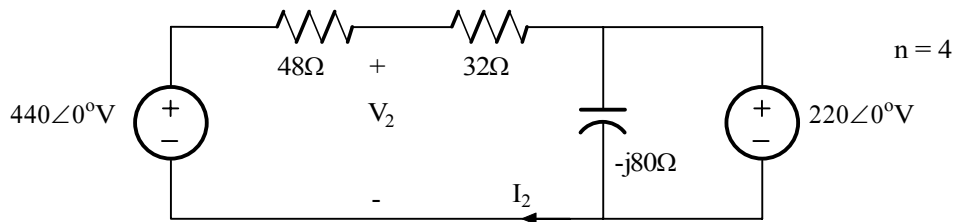

Figure P8.51

Suggested Solution



$$I_2 = (440 - 220) / (80) = 2.75 \angle 0^\circ \text{A} \quad V_2 = 220 + 32I_2 = 308 \angle 0^\circ \text{V}$$

$V_1 = V_2/n = 77 \angle 0^\circ \text{V}$

$I_1 = -nI_2 = 11 \angle 180^\circ \text{A}$

Problem 8.52

Determine the input impedance seen by the source in the circuit in Figure P8.52

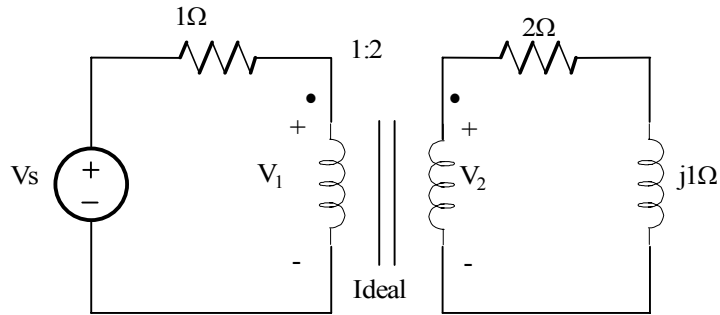
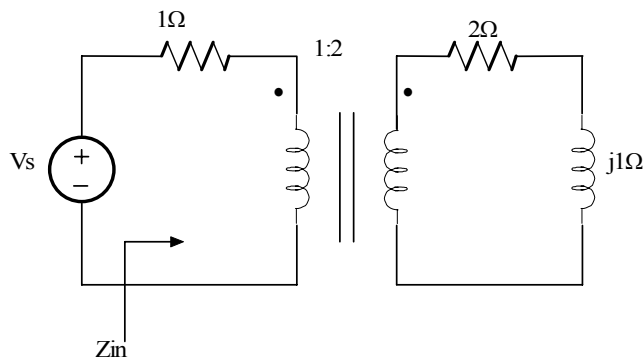

Figure P8.52

Suggested Solution



$$Z_L = 2 + j1\Omega \quad n = 2$$

$$Z_1 = Z_L / n^2 = (2 + j1) / 4 = 0.5 + j0.25$$

$$Z_{in} = 1 + Z_1 = 1.5 + j0.25\Omega$$

Problem 8.53

Determine the input impedance seen by the source in the circuit in Figure P8.53

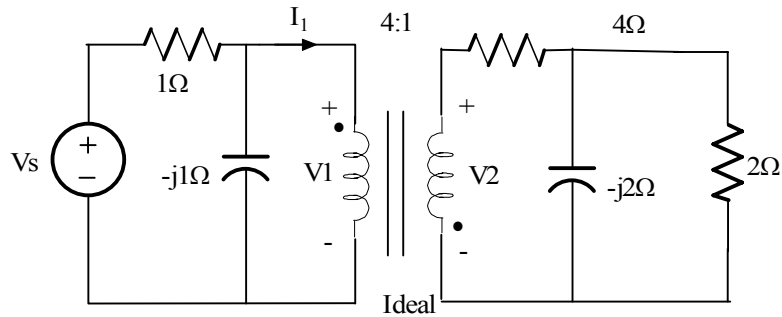
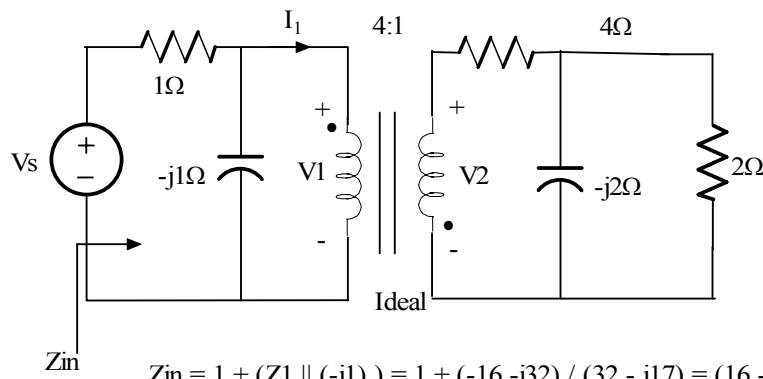

Figure P8.53

Suggested Solution



$$Z_L = 1 + 2 \parallel (-j2) = 2 - j1\Omega$$

$$n = 1/4$$

$$Z_1 = Z_L/n^2 = 32 - j16\Omega$$

$$Z_{in} = 1 + (Z_1 \parallel (-j1)) = 1 + (-16 - j32) / (32 - j17) = (16 - j49) / (32 - j17)$$

$Z_{in} = 1.42\angle -43.94^\circ\Omega$

Problem 8.54

Determine the input impedance seen by the source in the network shown in Figure P8.54

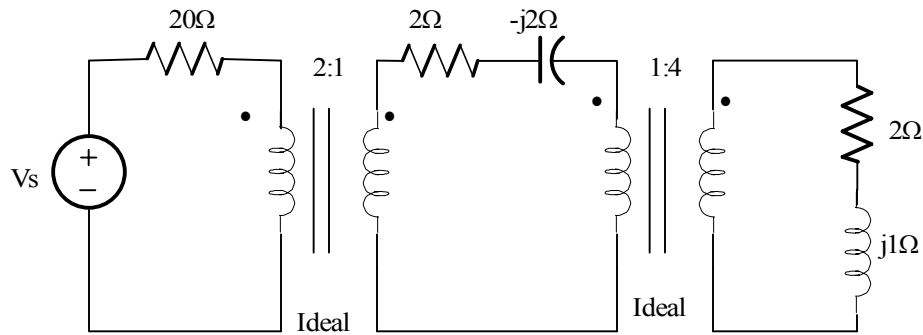
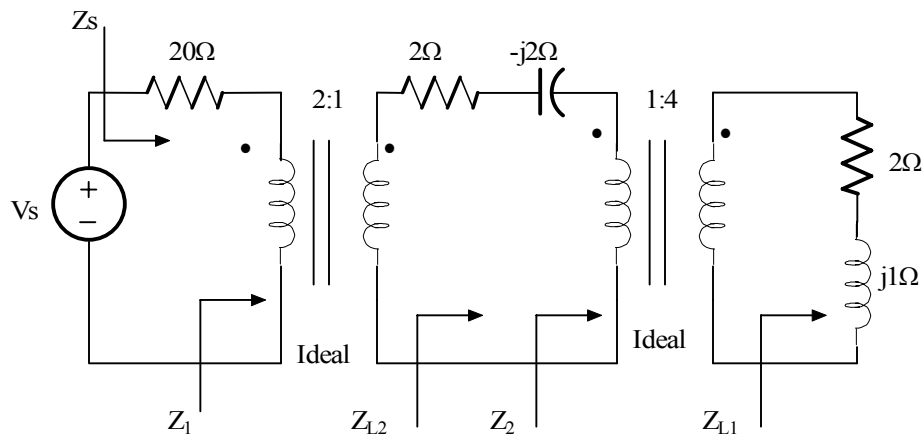

Figure P8.54

Suggested Solution



$$Z_{L1} = 2 + j1\Omega \quad n_2 = 1/2 \quad Z_2 = Z_{L1}/n_2^2 = (2 + j1)/(1/4) = 8 + j4\Omega$$

$$Z_{L2} = 2 - j2 + Z_2 = 10 + j2\Omega \quad n_1 = 1/4 \quad Z_1 = Z_{L2}/n_1^2 = 160 + j32\Omega$$

$$Z_s = 20 + Z_1 = 180 + j32\Omega$$

Problem 8.55

Determine the input impedance seen by the source in the network shown in Figure P8.55

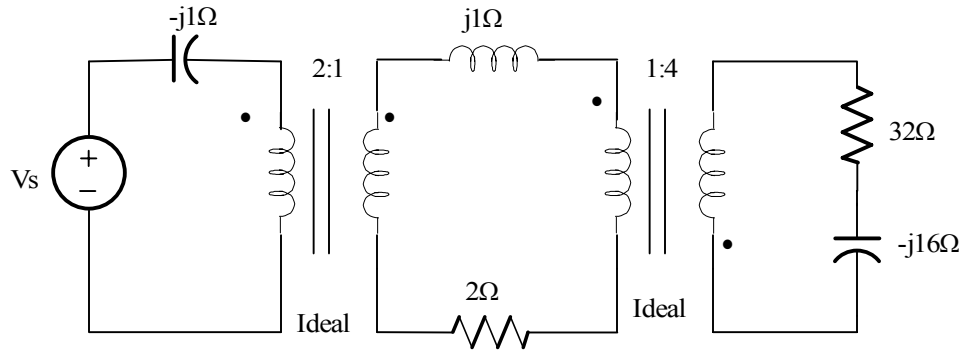
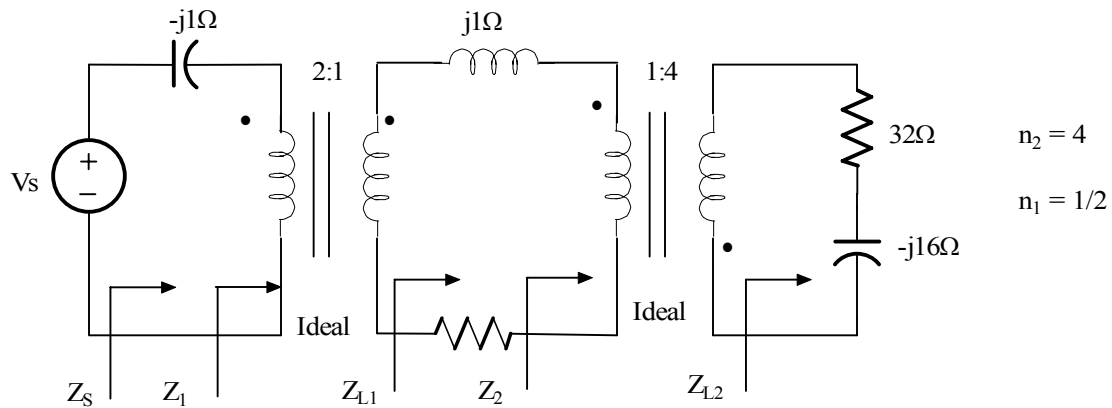

Figure P8.55

Suggested Solution



$$Z_{L2} = 32 - j16\Omega \quad Z_2 = Z_{L2} / n_2^2 = 2 - j1\Omega$$

$$Z_{L1} = 2 + j1 + Z_2 = 4\Omega \quad Z_1 = Z_{L1} / n_1^2 = 16\Omega$$

$Z_s = 16 - j1\Omega$

Problem 8.56

The output stage on an amplifier in an old radio is to be matched to the impedance of a speaker as shown in Figure P8.56. If the impedance of the speaker is 8 ohms and the amplifier requires a load impedance of 3.2 K ohms determine the turns ratio of the ideal transformer.

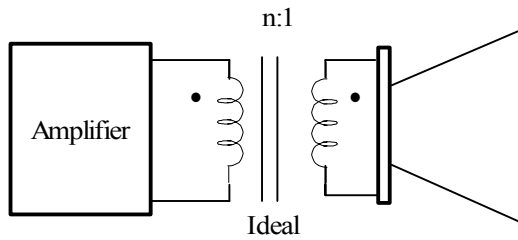
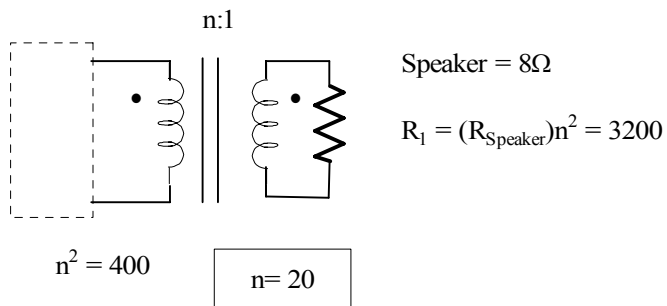

Figure P5.56

Suggested Solution



Problem 8.57

Given that $V_o = 48\angle 30^\circ$ V in the circuit shown in Figure P8.57, determine V_s

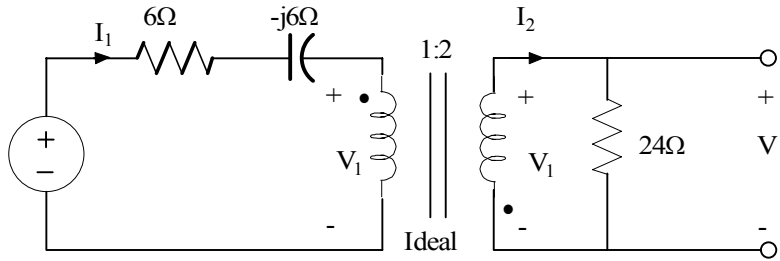
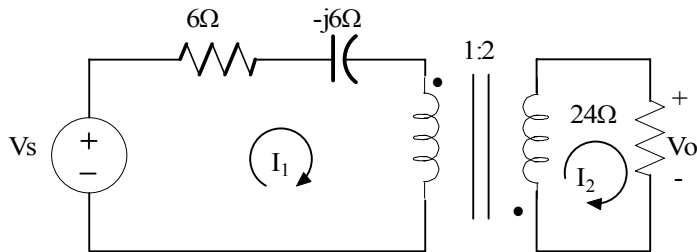

Figure P8.57

Suggested Solution



If $V_o = 48.30\angle 30^\circ$ V, find V_s

If $V_o = 48.30\angle 30^\circ$, $I_2 = 2\angle 30^\circ$

$V_1 = -V_2 / 2 = -24\angle 30^\circ$, $I_1 = -2I_2 = -4\angle 30^\circ$ V

Then $V_s = V_1 + I_1 (6 - 6j)$

$53.66\angle -175.7^\circ$ V

Problem 8.58

If the voltage source V_s in the circuit of Problem 8.57 is $50\angle 0^\circ\text{V}$, determine V_o .

Suggested Solution

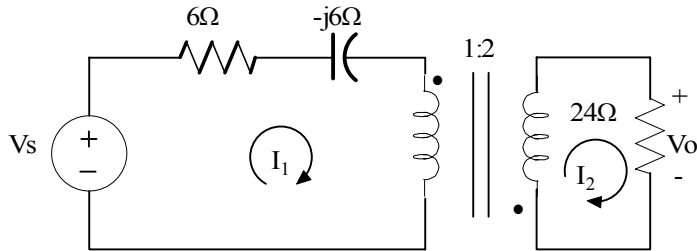

If $V_s = 50\angle 0^\circ\text{V}$, find V_o

$$I_1 = (50\angle 0^\circ) / (6 - 6j + 24/4) = 3.73\angle 26.6^\circ$$

$$\text{Then } I_2 = -I_1/2 = -1.86\angle 26.6^\circ$$

$$V_o = 24 I_2$$

$$44.72\angle -153^\circ\text{V}$$

Problem 8.59

Determine V_s in the circuit in Figure P8.59

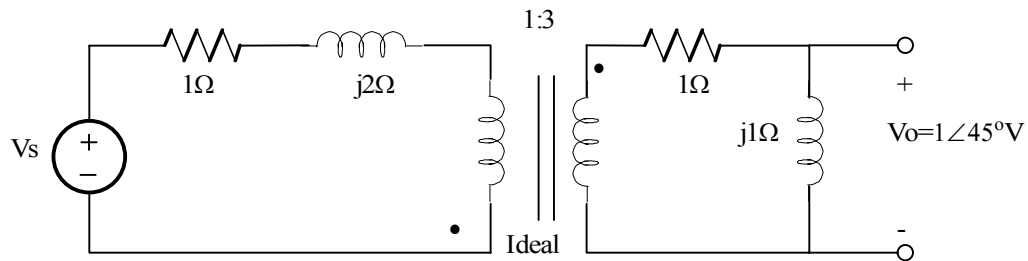
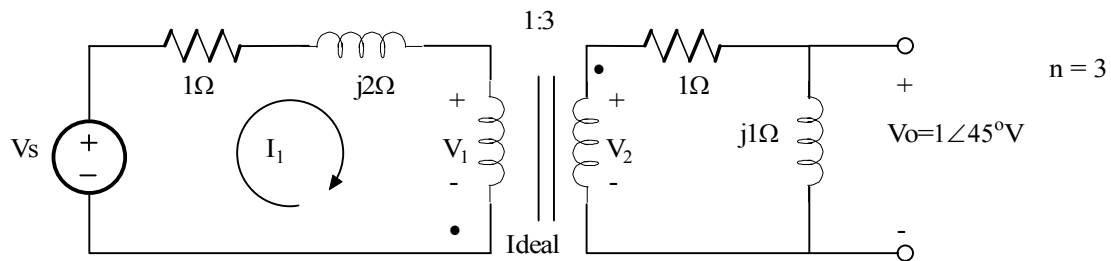

Figure P8.59

Suggested Solution



$$I_2 = V_o / (j1) = 1\angle-45^\circ \text{ A} \quad V_2 = I_2(1 + j1) = 1.41 \text{ V}$$

$$V_1 = -V_2/n = 0.47\angle180^\circ \text{ V} \quad I_1 = -nI_2 = 3\angle135^\circ \text{ A}$$

$$V_s = I_1(1 + j2) + V_1 = 6.71\angle-161.57^\circ + 0.47\angle180^\circ \text{ V}$$

$V_s = 7.16\angle-162.76^\circ \text{ V}$

Problem 8.60

Determine I_s in the circuit in Figure P8.60

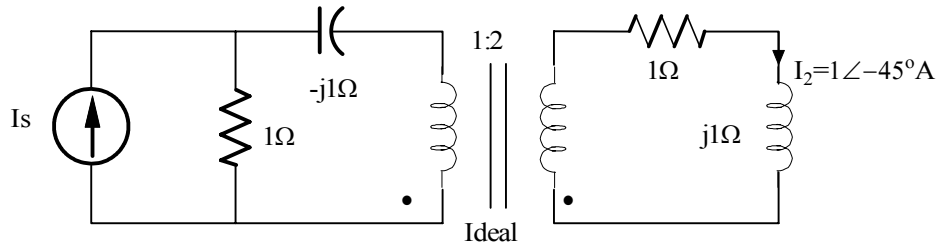
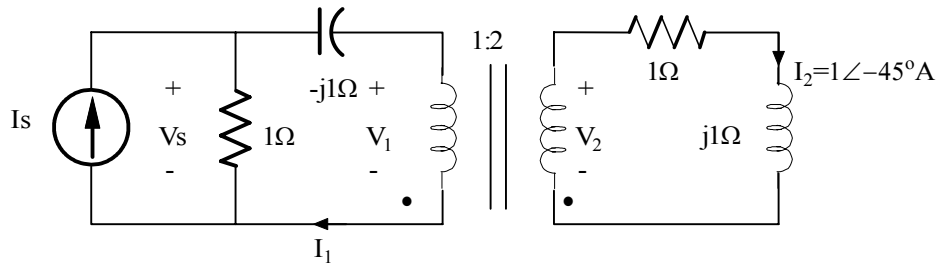

Figure P8.60

Suggested Solution



$$V_2 = (1 + j1)I_2 = 1.41\angle 0^\circ \text{V} \quad V_1 = V_2/n = 0.707\angle 0^\circ \text{V}$$

$$I_1 = nI_2 = 2\angle -45^\circ \text{A}$$

$$V_s = V_1 - j1 I_1 = 0.707\angle 0^\circ + 2\angle -135^\circ = 1.58\angle -116.57^\circ \text{V}$$

$$I_s = V_s / 1 + I_1$$

$$I_o = 2.91\angle -75.95^\circ \text{A}$$

Problem 8.61

Find the current I in the network in Figure P8.61

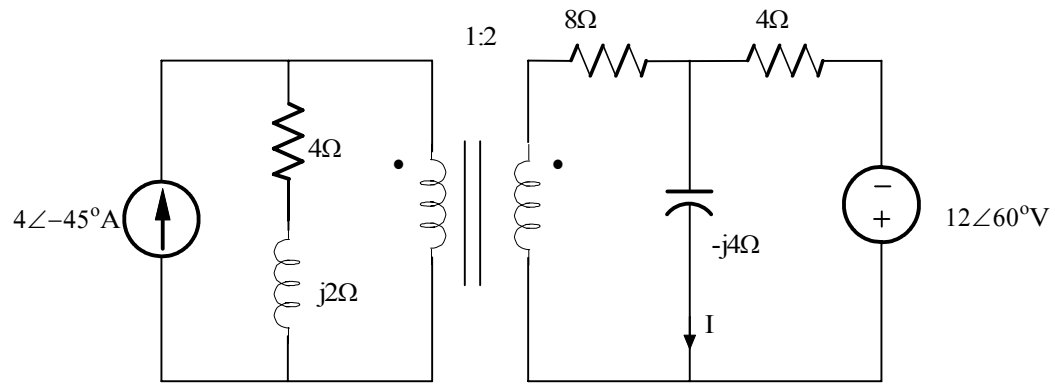
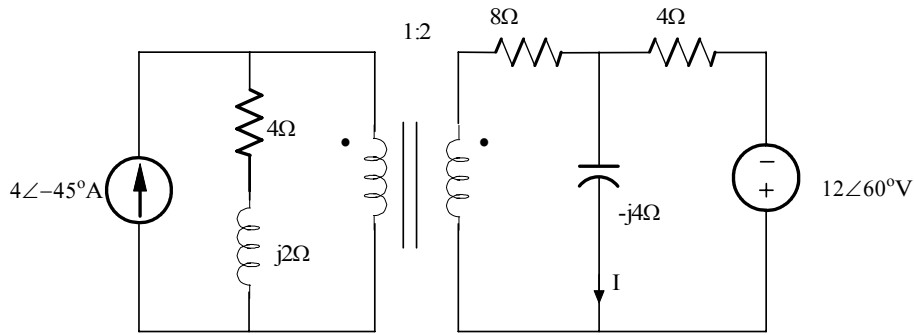

Figure P6.61

Suggested Solution



Refer primary to secondary

$$I_{sec} = I_{prim} / n \quad Z_{sec} = Z_{prim} n^2$$

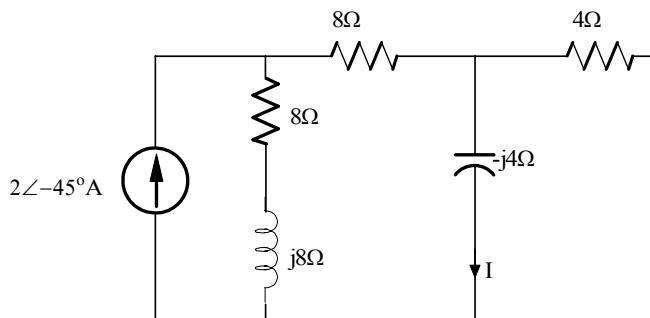

Source transformations

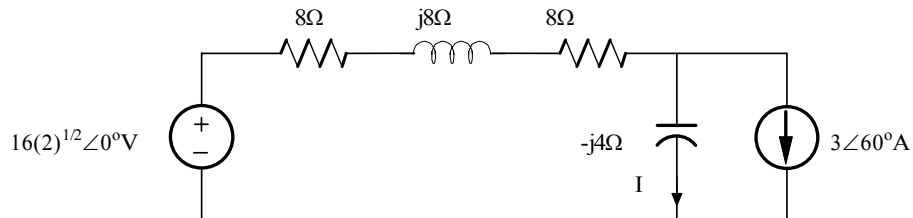

Another source transformation

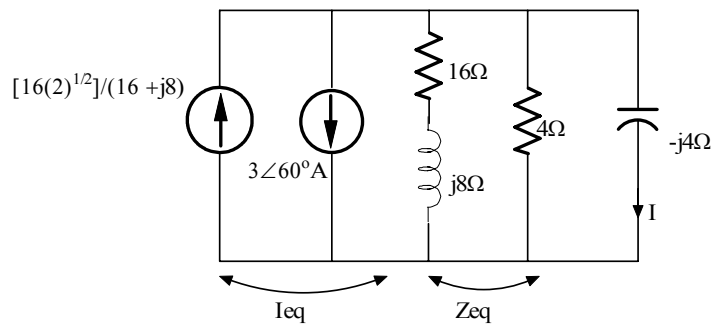

$$I_{eq} = [16(2)^{1/2}] / (16 + j8) - 3\angle 60^\circ = 3.19\angle -96.64^\circ \text{ A} \quad Z_{eq} = 4 / (16 + j8) = 3.32\angle 4.76^\circ \Omega$$

$$I = I_{eq} [Z_{eq} / (Z_{eq} - j4)] = 2.13\angle -43.50^\circ$$

$$I = 2.13\angle -43.50^\circ \text{ A}$$

Problem 8.62

Find the voltage V_o in the network in Figure P8.62

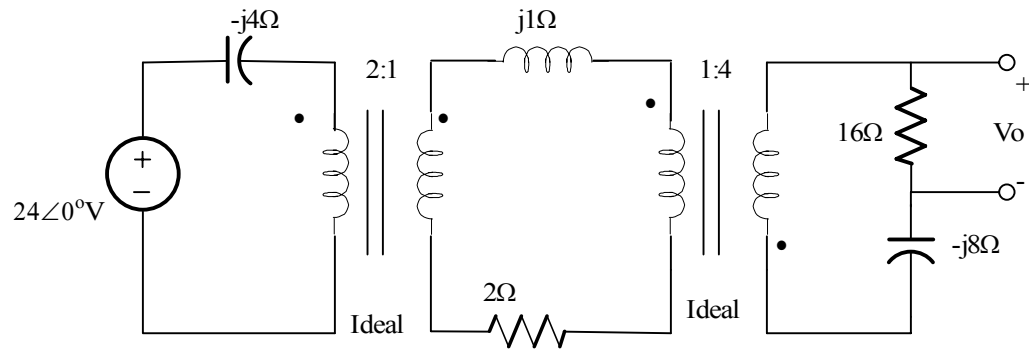
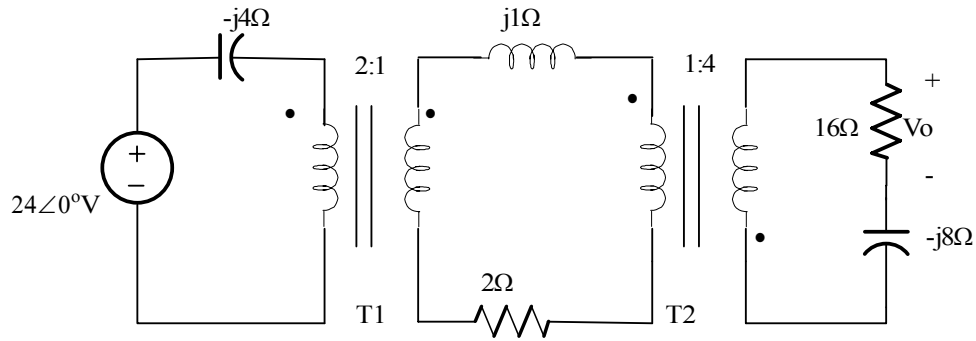

Figure 8.62

Suggested Solution



Refer primary circuit of T1 to secondary: $n_1 = 1/2$

$$V_{\text{sec}} = V_{\text{prim}} n_1 \quad Z_{\text{sec}} = Z_{\text{prim}} n_1^2$$

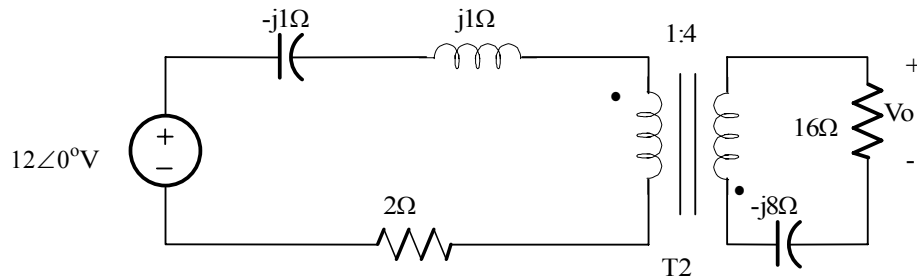

Refer primary circuit of T2 to secondary: $n_2 = 4$ (Dots reversed!)

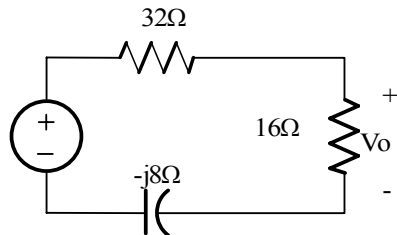

$$V_o = -48 [16 / (48 - j8)] = -96 / (6 - j1)$$

$$V_o = 15.78 \angle 189.46^\circ \text{V}$$

Problem 8.63

Find V_o in the network in Figure P8.63

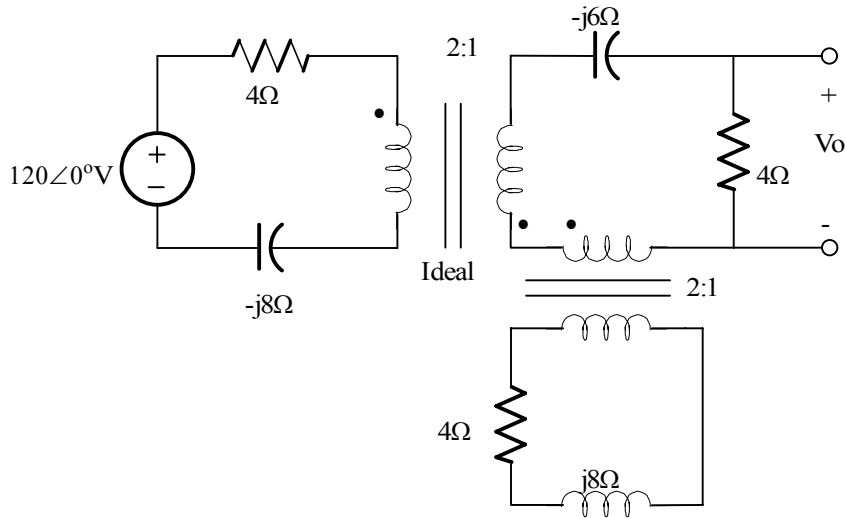
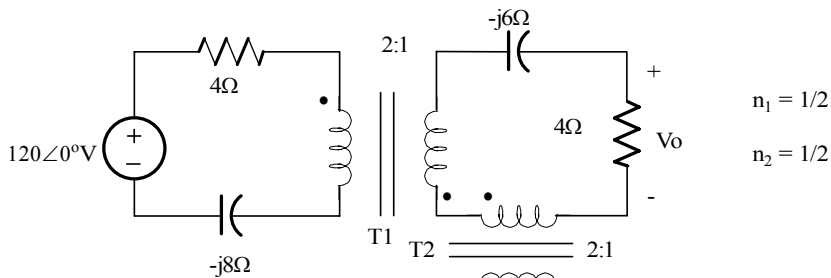
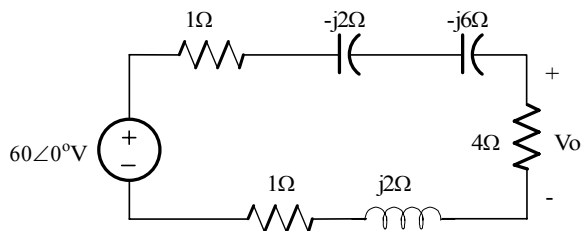

Figure P8.63

Suggested Solution



Refer primary of T1 to secondary
and secondary of T2 to primary.



$$V_o = (-60)(4) / (6 - j2 + j2 - j6) = (-40) / (1 - j1)$$

$V_o = 28.28\angle-135^\circ \text{ V}$

Problem 8.64

Find V_o in the circuit in Figure P8.64

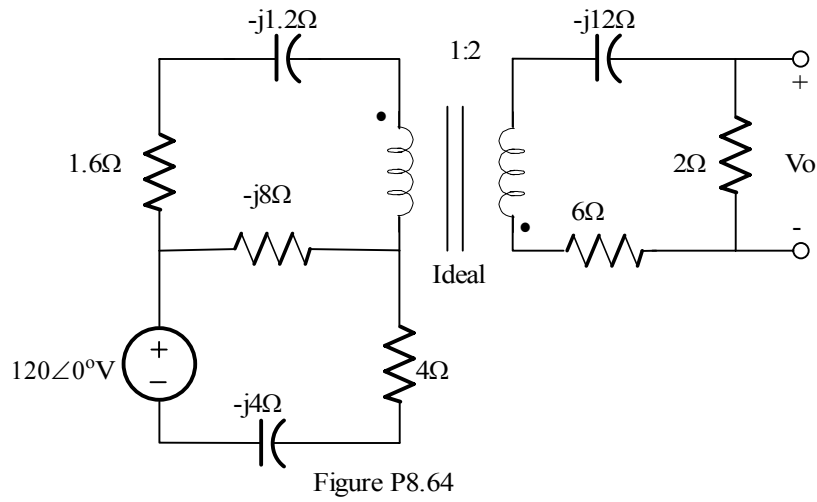

Suggested Solution

Thevenin Eq.

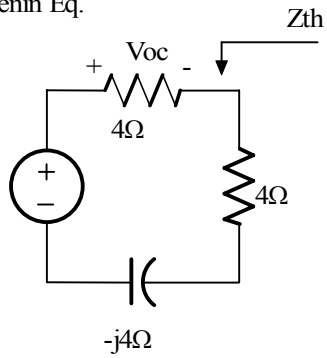

$$V_{oc} = 120 [4 / (8 - j4)] = 120 / (2 - j1)$$

$$Z_{th} = 4 \parallel (4 - j4) = (4 - j4) / (2 - j1) = 2.4 - j0.8 \Omega$$

New circuit

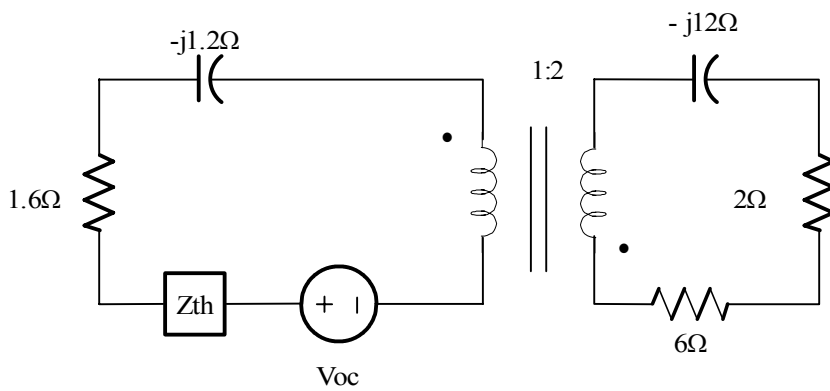

Refer secondary circuit to primary

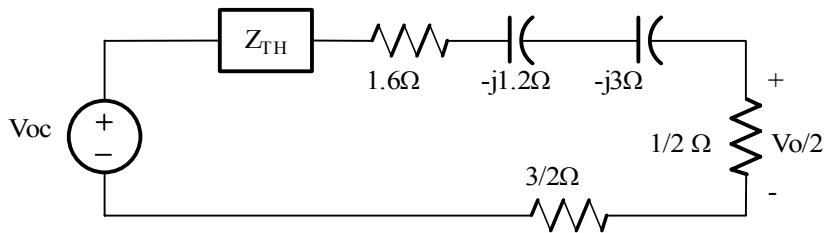

$$V_{o/2} = -V_{oc} [0.5 / (3.6 - j4.2 + Z_{th})]$$

$$V_o = 6.81 \angle -113.630^\circ \text{ V}$$

Problem 8.65

Find V_o in the circuit in Figure P8.65

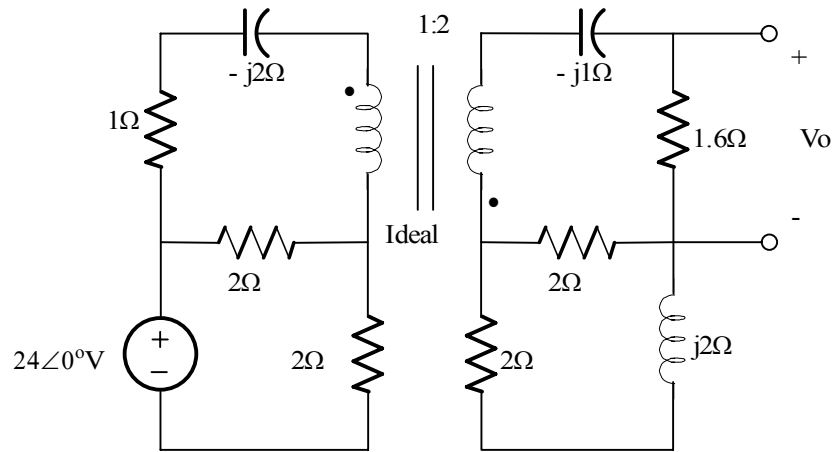
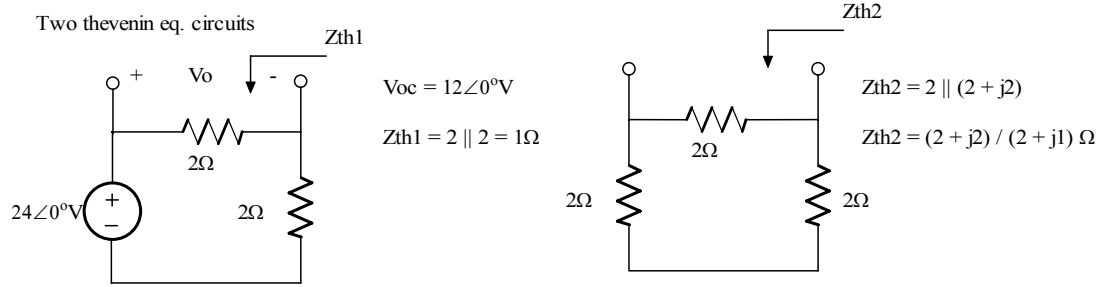
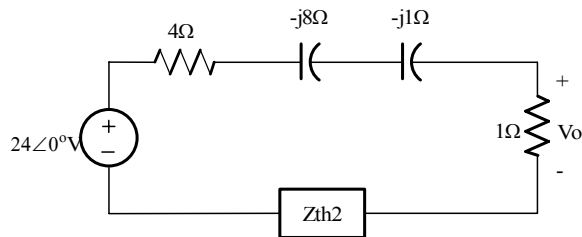
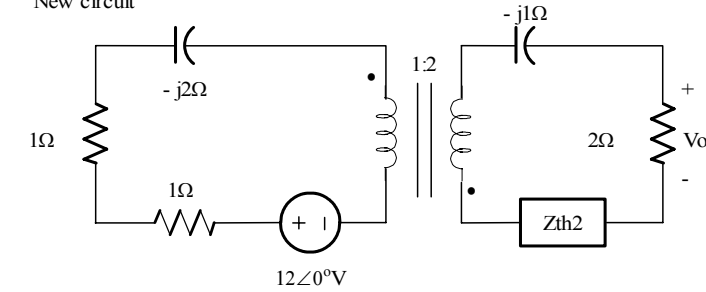

Figure P8.65

Suggested Solution



New circuit



$$V_o = -24 \left[\frac{1}{9 - j9 + Z_{th2}} \right] = \frac{-24(2 + j1)}{[(9 - j9)(2 + j1) + 2 + 2]} = \frac{-24(2 + j1)}{(18 + 9 + 2 + j9 - j18 + j2)}$$

$$V_o = \frac{-24(2 + j1)}{(29 - j7)}$$

$V_o = 1.80\angle -139.86^\circ\text{V}$

Problem 8.66

In the circuit of Figure P8.66, if $I_x = 6\angle 45^\circ \text{A}$, find V_o .

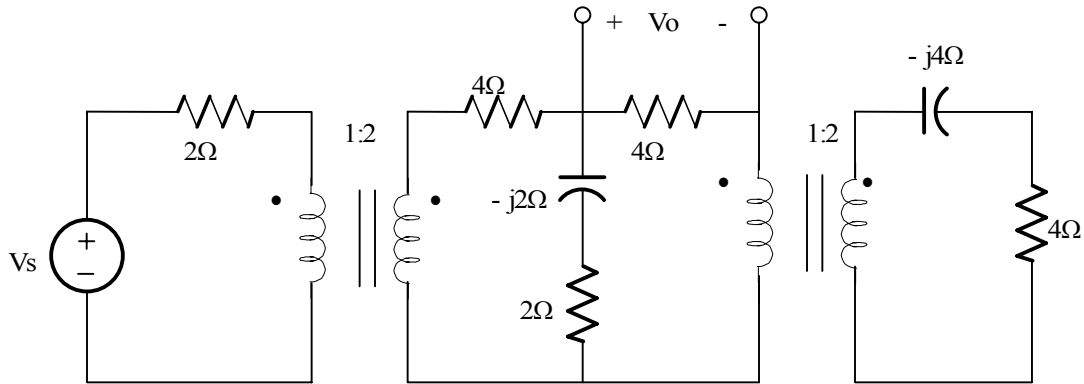
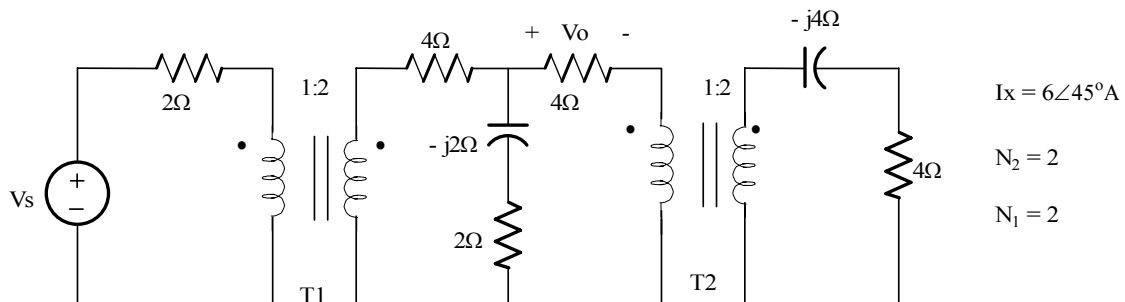
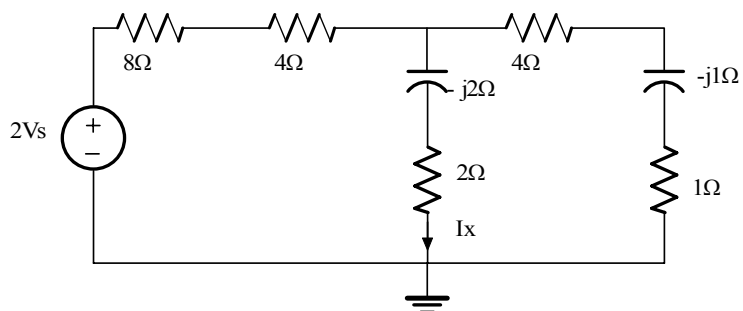

Figure P8.66

Suggested Solution



Refer primary of T1 to secondary and secondary of T2 to primary



$$V_x = I_x (2 - j2) = 6\angle 45^\circ (2 - j2) = 16.97\angle 11.31^\circ \text{ V}$$

$$V_o = V_x \left[\frac{4}{4 + 1 - j1} \right] = 4 V_x / (5 - j1)$$

$$V_o = 13.31\angle 11.31^\circ \text{ V}$$

Problem 8FE-1

In the network in Figure 8PFE-1 find the impedance seen by the source.

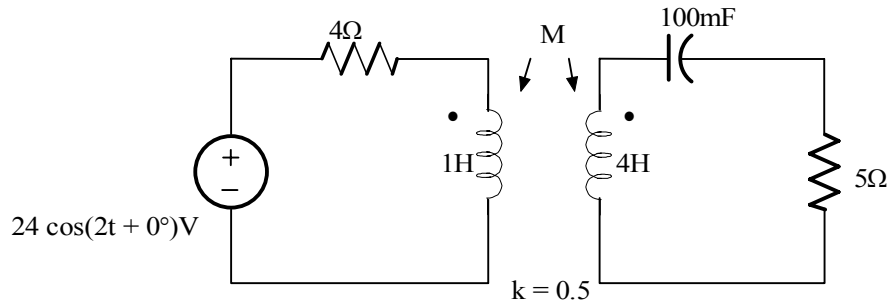
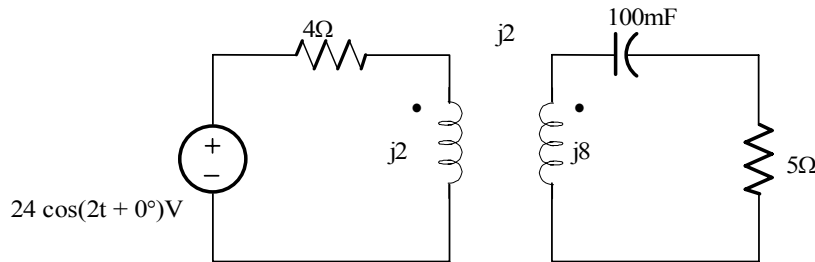

Figure 8PFE-1

Suggested Solution

$$\text{Since } M = k(L_1 L_2)^{1/2} = (0.5)(2) = 1\text{H}$$



$$V_1 = (4 + j2)I_1 - j2I_2$$

$$0 = -j2I_1 + (5 + j3)I_2$$

$$I_2 = (j2I_1)/(5 + j3)$$

$$V_1 = (4 + j2)I_1 - j2(j2)/(5 + j3) I_1 = [4 + j2 + 4/(5 + j3)] I_1$$

$$Z_s = V_1/I_1 = (18 + j22)/(5 + j3)$$

$Z_s = 4.88 \angle 19^\circ \Omega$

Problem 8FE-2

In the circuit in Figure 8PFE-2, select the value of the transformer's turns ratio $n = N_2/N_1$ to achieve impedance matching or maximum power transfer. Using this value of n calculate the power absorbed by the 3-Ohm resistor.

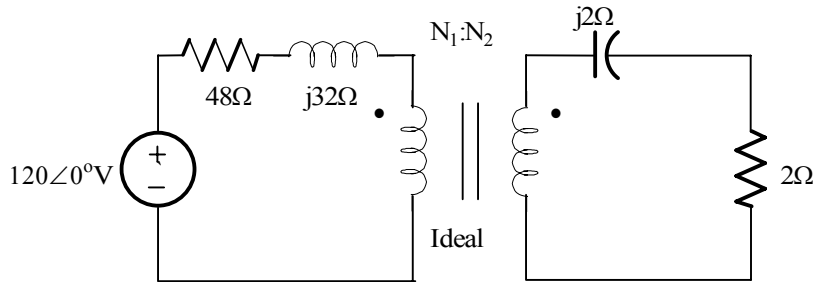

Figure P8PFE-2

Suggested Solution

The reflected impedance is $Z = Z_L/n^2$

The value of n that will make the reflected impedance the complex conjugate of the impedance in the primary is:

$$\underline{n = 1/4} \quad \text{i.e. } (1/4)^2 (48 + j32) = (3 - j2)^* \quad \text{and } \underline{P_{3\Omega} = (1/2)(120/96)^2(48) = 37.5W}$$

Problem 8FE-3

In the circuit in Figure 8FE-3, select the turns ratio of the ideal transformer that will match the output of the transistor amplifier to the speaker represented by the 16-Ohm load.

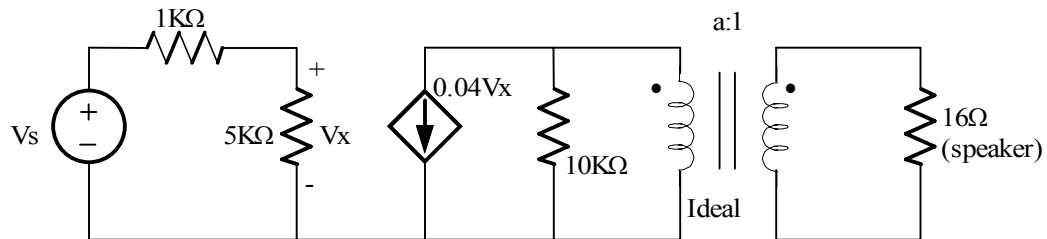

Figure P8PFE-3

Suggested Solution

$$a^2(16) = 10\text{K} \Rightarrow \underline{a = 25}$$

Problem 8FE-4

Find the power absorbed in the 1-Ohm load in the network in Figure 8PFE-4

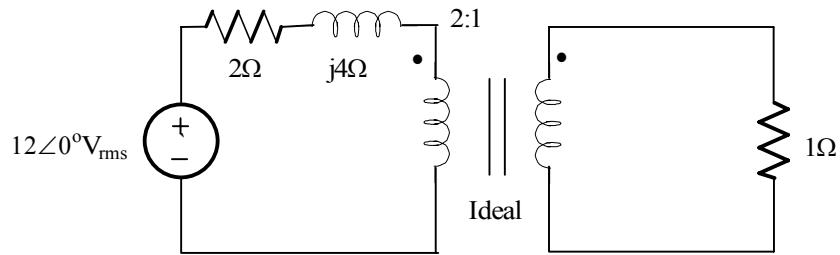
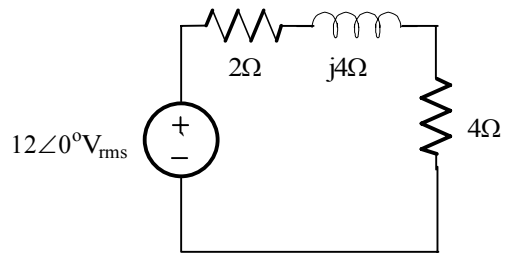

Figure PFE-4

Suggested Solution



$$I = 12\angle 0^\circ / (6 + j4) = 1.664\angle -33.69^\circ \text{ Amps}$$

$$P = (1.664)^2(4) = 11.1\text{W}$$

Problem 8FE-5

Determine the average power absorbed by the 1-Ohm resistor in the network in Figure 8PFE-5.

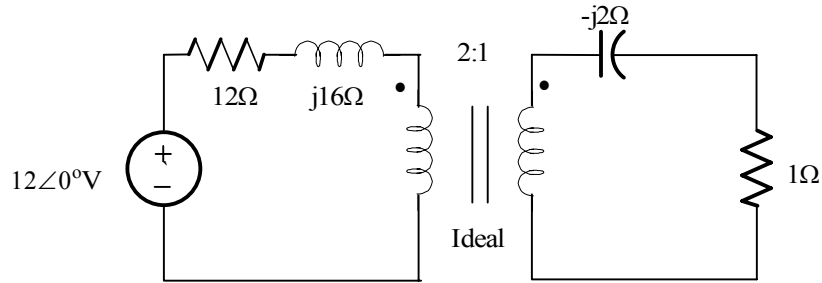
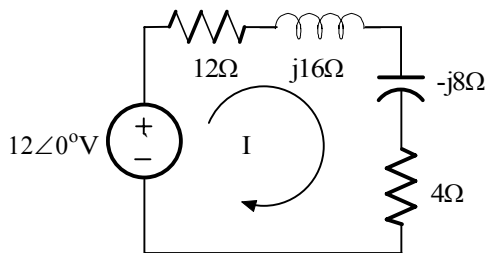

Figure PFE-5

Suggested Solution



$$I = 12 / (16 + j8) = 0.07 \angle -26.57^\circ \text{ Amps}$$

$$P = 0.5(0.67)^2(4) = 0.9\text{W}$$

Problem 9.1

Determine the equations for the current and the instantaneous power in the network in Figure P 9.1

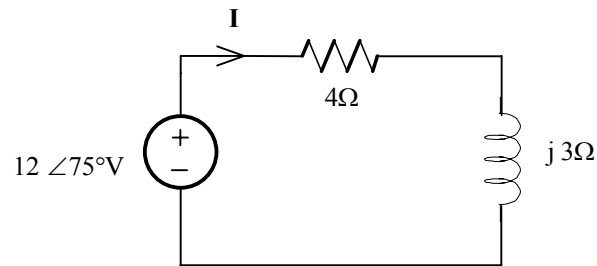

Figure P 9.1

Suggested Solution

$$I = \frac{12 \angle 75^\circ}{4 + j3} = \frac{12 \angle 75^\circ}{5 \angle 36.90^\circ} = 2.4 \angle 38.1^\circ A$$

$$L(t) = 2.4 \cos(\omega t + 38.1^\circ) A$$

$$P(t) = \frac{12 \times 2.4}{2} (\cos 36.9^\circ + \cos(2\omega t + 75^\circ + 38.1^\circ))$$

$$= 11.51 + 14.4 \cos(2\omega t + 113.1^\circ) W$$

Problem 9.2

Determine the equations for the voltage and instantaneous Power in the network in Figure P 9.2

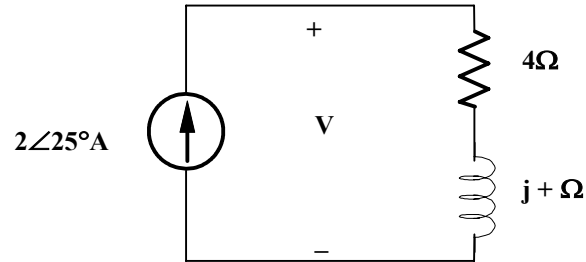

Figure P 9.2

Suggested Solution

$$V = IZ = (2\angle 25^\circ)(4 + j4) = 11.3\angle 70^\circ V$$

$$L(t) = 2 \cos(\omega t + 25^\circ) A \text{ \& } V(t) = 11.3 \cos(\omega t + 70^\circ) V$$

$$P(t) = \frac{2 \times 11.3}{2} [\cos 45^\circ + \cos(2\omega t + 95^\circ)]$$

$$= 8 + 11.3 \cos(2\omega t + 95^\circ) W$$

Problem 9.3

Find the average power absorbed by the network shown in Figure P 9.3

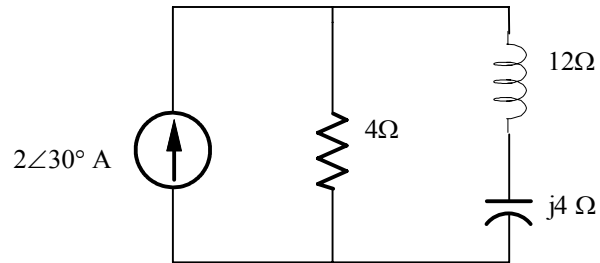

Figure P 9.3

Suggested Solution

Using Current division

$$I_R = \frac{(2\angle 30^\circ)(-j4 + j2)}{4 - j4 + j2} = .89\angle -33.43^\circ \text{ A}$$

Then

$$P = \frac{1}{2} I_M^2 R = \frac{1}{2} (.89^2)(4) = \boxed{1.58 \text{ W}}$$

Problem 9.4

Given the network in Fig. P 9.4, find the power supplied and the average power absorbed by each element.

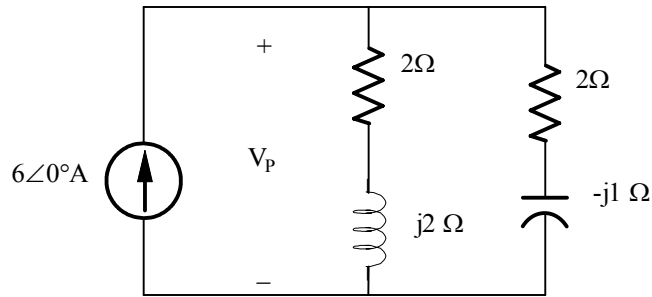

Figure 9.4

Suggested Solution

$$Z_T = \frac{(2 + 2j)(2 - j)}{2 + j2 + 2 - j} = \frac{6 + j2}{4 + j}$$

$$V_T = I_T Z_T = (6\angle 0^\circ) \left(\frac{6.32\angle 18.43^\circ}{4.12\angle 14.04^\circ} \right) = 9.2\angle 4.39^\circ V$$

$$P_S = \frac{1}{2} (9.2)(6) \cos(4.39^\circ - 0^\circ) = 27.52 W$$

$$I_1 = \frac{(6\angle 0^\circ)(2 - j)}{4 + j1} = 3.26\angle -40.61^\circ A$$

$$I_2 = \frac{(6\angle 0^\circ)(2 + j2)}{4 + j1} = 4.12\angle 30.96^\circ A$$

$$P_A = \frac{1}{2} I_1^2 R_1 + \frac{1}{2} I_2^2 R_2 = \frac{1}{2} [(3.26)^2 (2) + (4.12)^2 (2)]$$

$$P_A = \boxed{27.61 W}$$

Problem 9.5

Given the circuit in Fig. 9.5, find the average power supplied and the average power absorbed by each element.

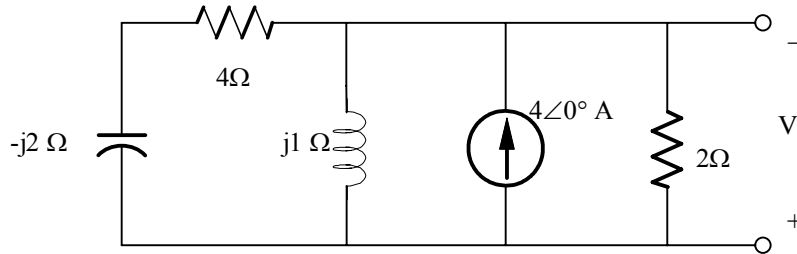
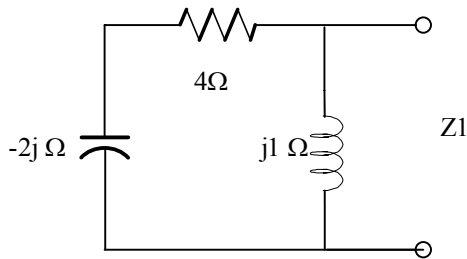

Figure P 9.5

Suggested Solution



$$Z_1 = [(4 - j2)(j1)] / (4 - j2 + j1) = (2 + j4) / (4 - j)$$

$$Z_T = \frac{2(Z_1)}{2 + Z_1} = \frac{4 + j8}{10 + j2}$$

$$V = (4 \angle 0^\circ)(Z_T) = 3.51 \angle 52.12^\circ V$$

$$P_S = \frac{1}{2}(4)(V) \cos(52.12^\circ - 0^\circ) = 4.31 W$$

$$I_{2\Omega} = \frac{4 \angle 0^\circ (Z_1)}{Z_1 + 2} = 1.75 \angle 52.12^\circ A$$

$$I_{4\Omega} = \frac{4 \angle 0^\circ (2)}{Z_1 + 2} \left(\frac{-j1}{4 - j} \right) = .78 \angle 78.69^\circ A$$

$$P_{2\Omega} = \frac{1}{2} I_{2\Omega}^2 (2) = \frac{1}{2} (1.75)^2 (2) = \boxed{3.06 W}$$

$$P_{4\Omega} = \frac{1}{2} I_{4\Omega}^2 (4) = \frac{1}{2} (.78)^2 (4) = \boxed{1.23 W}$$

Problem 9.6

Compute the average power absorbed by the elements to the right of the dashed line in the network shown in Fig. P 9.6

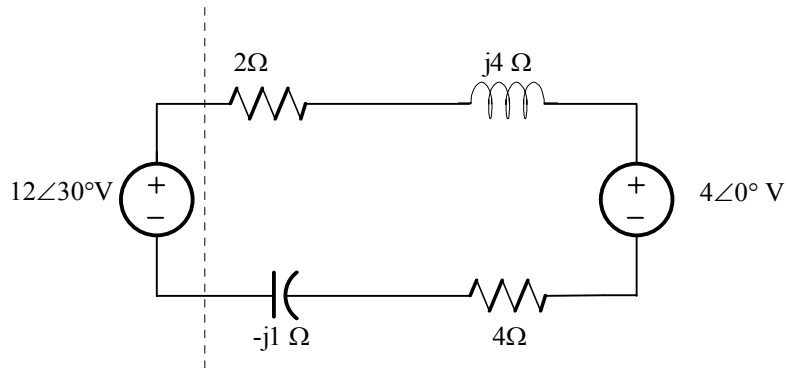
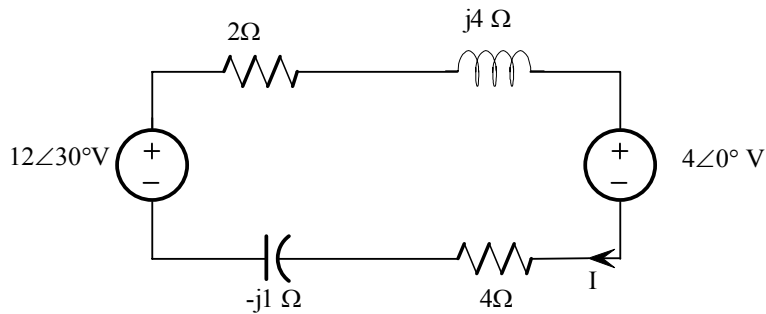

Figure P 9.6

Suggested Solution



$$P_L = 0 \text{ W} \quad P_C = 0 \text{ W}$$

$$P_{R1} = (I^2 R_1)/2 \quad P_{R2} = (I^2 R_2)/2$$

$$I = \frac{12\angle 30^\circ - 4\angle 0^\circ}{2 + 4 + j4 - j1} = \frac{12\angle 30^\circ - 4\angle 0^\circ}{6 + j3} = \frac{8.77\angle 43.19^\circ}{6.71\angle 26.57^\circ} \text{ A}$$

$$I = 1.31\angle 16.62^\circ \text{ A} \Rightarrow I = 1.31 \text{ A}$$

$$P_{R1} = \left(\frac{1}{2}\right)(1.31)^2(2) = 1.72 \text{ W}$$

$$P_{R2} = \left(\frac{1}{2}\right)(1.31)^2(4) = 3.43 \text{ W}$$

$P_L = 0 \text{ W}$	$P_C = 0 \text{ W}$	$P_{R1} = 1.72 \text{ W}$	$P_{R2} = 3.43 \text{ W}$
---------------------	---------------------	---------------------------	---------------------------

Problem 9.7

Given the network in Fig. 9.7, determine which elements are supplying power, which ones are absorbing power, and how much power is being supplied and absorbed.

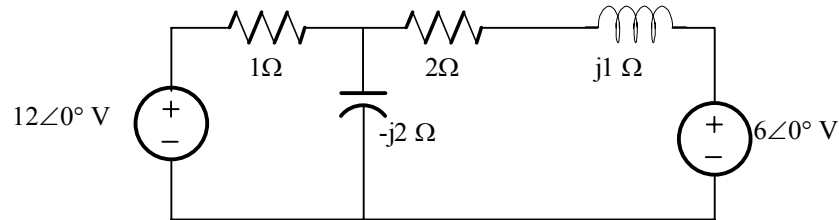

Figure P 9.7

Suggested Solution

The mesh currents are obtained from the equations:

$$(I - j2)I_1 + j2I_2 = 12\angle 0^\circ$$

$$j2I_1 + (2 - j)I_2 = -6\angle 0^\circ$$

$$\text{or } \begin{bmatrix} I_1 \\ I_2 \end{bmatrix} = \frac{1}{4 - j5} \begin{bmatrix} 2 - j & -j2 \\ -j2 & 1 - j2 \end{bmatrix} \begin{bmatrix} 12\angle 0^\circ \\ -6\angle 0^\circ \end{bmatrix}$$

$$= \begin{bmatrix} 3.75\angle 51.39^\circ \\ 2.1\angle -65.16^\circ \end{bmatrix}$$

$$P_{12\angle 0^\circ} = \frac{1}{2}(12)(3.75)\cos(0 - 51.39^\circ) = \boxed{14.04W \text{ Sup}}$$

$$P_{1\Omega} = \frac{1}{2}(3.75)^2(1) = \boxed{7.03W \text{ Abs}}$$

$$P_{2\Omega} = \frac{1}{2}(2.10)^2(2) = \boxed{4.41W \text{ Abs}}$$

$$P_{6\angle 0^\circ} = \frac{1}{2}(6)(2.10)\cos(0 + 65.16^\circ) = \boxed{2.65W \text{ Abs}}$$

Problem 9.8

Given the circuit in Fig P 9.8 find the average power absorbed by the network.

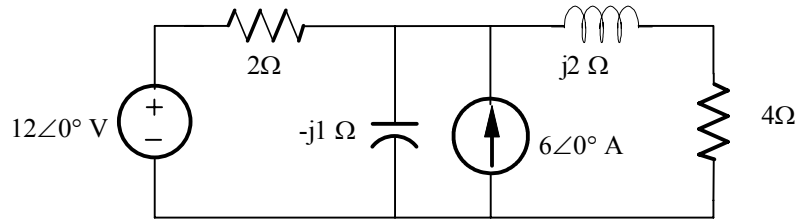
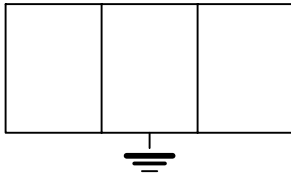

Figure P 9.8

Suggested Solution

V_1



The nodal equation is:

$$(V_1 - 12)/2 + V_1/(-j) + V_1/(4 + j2) = 6\angle 0^\circ$$

Solving yields: $V_1 = 6.46 - j8.3V = 10.52\angle -52.12^\circ V$

$$I_{\rightarrow 2\Omega} = \frac{12 - 6.46 + j8.3}{2} = 4.99\angle 56.28^\circ A$$

$$I_{4\Omega} = \frac{10.50\angle -52.12^\circ}{4 + j2} = 2.35\angle -78.69^\circ A$$

$$P_s = \frac{1}{2}(12)(4.99)\cos(0 - 56.28^\circ) + \frac{1}{2}(10.52)(6)\cos(-52.12^\circ - 0^\circ)$$

$$= 16.62 + 19.38 = \boxed{36W}$$

$$P_{abs} = \frac{1}{2}(4.99)^2(2) + \frac{1}{2}(2.35)^2(4)$$

$$= 24.9 + 11.05 = \boxed{35.95W}$$

Problem 9.9

Given the network in Fig 9.9, find the average power supplied to the circuit.

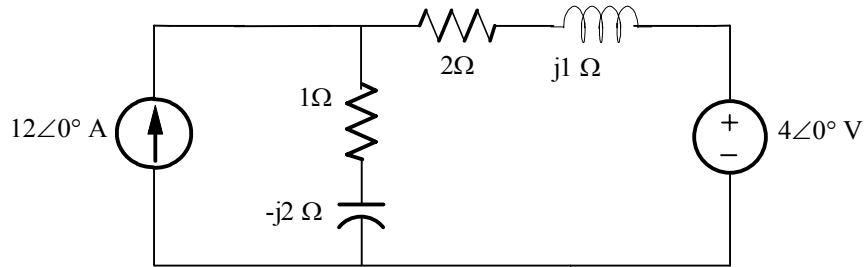
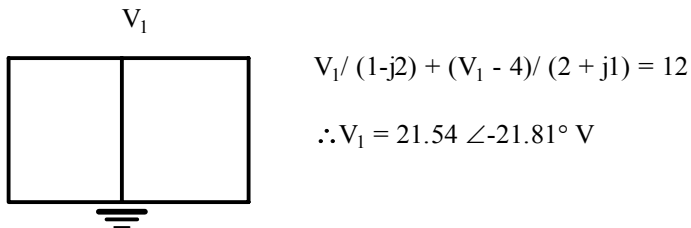

Figure P 9.9

Suggested Solution



$$V_1 / (1 - j2) + (V_1 - 4) / (2 + j1) = 12$$

$$\therefore V_1 = 21.54 \angle -21.81^\circ \text{ V}$$

$$I_{1\Omega} \downarrow = \frac{21.54 \angle -21.81^\circ}{1 - j2} = 9.63 \angle 41.62^\circ \text{ A}$$

$$I_{2\Omega} \rightarrow = \frac{21.54 \angle -21.81^\circ - 4}{2 + j1} = 8 \angle -53.1^\circ \text{ A}$$

$$P_s = \frac{1}{2} (12)(21.54) \cos(-21.81^\circ - 0^\circ) = 119.99 \text{ W}$$

$$P_{abs} = \frac{1}{2} (9.36)^2 (1) + \frac{1}{2} (8)^2 (2) + \frac{1}{2} (4)(8) \cos 53.13^\circ$$

$$= 46.37 + 64 + 9.6 = \boxed{119.97 \text{ W}}$$

Problem 9.10

Given the circuit in Fig. P 9.10, determine the amount of average power supplied to the network.

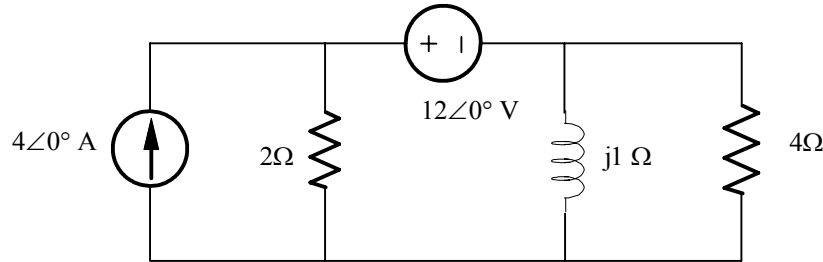
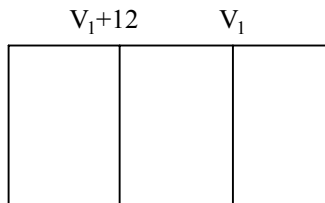

Figure P 9.10

Suggested Solution



$$(V_1 + 12)/2 + V_1/j + V_1/4 = 4$$

$$\therefore V_1 = (-8)/(3 - 4j) = -1.6\angle 53.13^\circ \text{ V}$$

$$I_{2\Omega} \downarrow = \frac{V_1 + 12}{2} = 5.56\angle -6.61^\circ \text{ A}$$

$$I_{4\Omega} = \frac{V_1}{2} = -.4\angle 53.13^\circ \text{ A}$$

$$I_{12\angle 0^\circ} = I_{2\Omega} - 4\angle 0^\circ = 1.65\angle -22.83^\circ \text{ A}$$

$$P_s = \frac{1}{2}(12)(1.65)\cos 22.83^\circ + \frac{1}{2}(11.11)(4)\cos(-6.61^\circ) = 31.19 \text{ W}$$

$$P_{abs} = \frac{1}{2}(5.56)^2(2) + \frac{1}{2}(.4)^2(4) = 30.91 + .32 = \boxed{31.23 \text{ W}}$$

Problem 9.11

Determine the average power absorbed by the 4- Ω resistor in the network shown in Fig. P 9.11

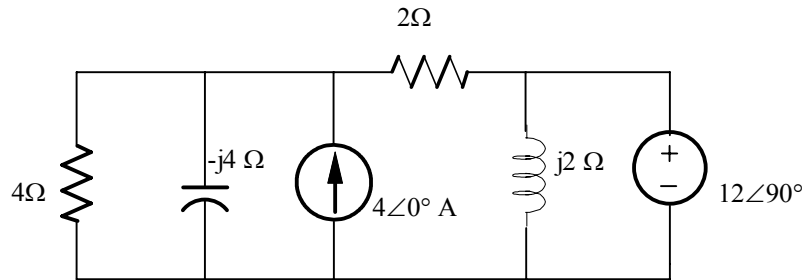

Figure P 9.11

Suggested Solution

Let V_1 be the voltage across the 4Ω resistor.

$$\frac{V_1}{4} + \frac{V_1}{-j4} + \frac{V_1 - 12\angle 90^\circ}{2} = 4$$

$$\therefore V_1 = 9.13\angle 37.88^\circ V$$

$$I_{4\Omega} = \frac{V_1}{4} = 2.28\angle 37.88^\circ A$$

$$P_{4\Omega} = \frac{1}{2}(2.28)^2(4) = \boxed{10.4W}$$

Problem 9.12

Given the network in Fig. P 9.12, show that the power supplied by the source is equal to the power absorbed by the passive elements.

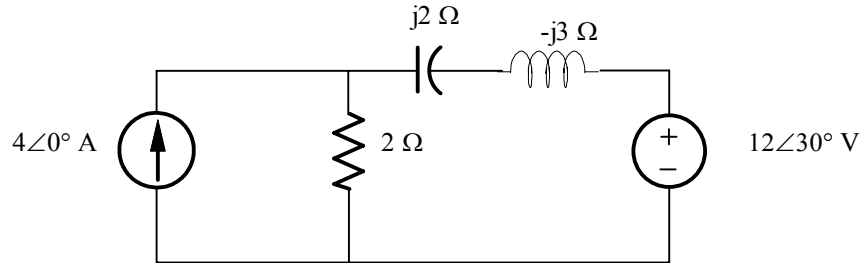
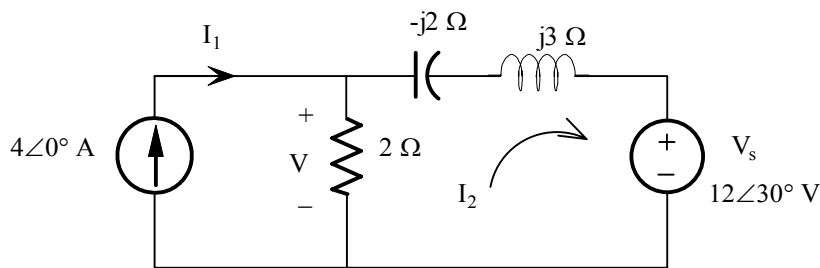

Figure P 9.12

Suggested Solution



Mesh Equations

$$I_1 = 4\angle 0^\circ A$$

$$-12\angle 30^\circ = I_2(2 + j1) - 2I_1$$

Find I_2

$$I_2 = \frac{2I_1 - 12\angle 30^\circ}{2 + j1} = \frac{8\angle 0^\circ - 12\angle 30^\circ}{2 + j1} = 2.89\angle -138.30^\circ A$$

Find V

$$V = (I_1 - I_2)(2) = (4\angle 0^\circ - 2.89\angle -138.30^\circ)(2) = 12.90\angle 17.30^\circ V$$

Power Delivered by current source

$$P_I = \frac{1}{2} V I_1 \cos \theta = \frac{1}{2} (12.90)(4) \cos(17.35 - 0) =$$

$$\boxed{P_I = 24.63W}$$

Power Delivered by voltage source

$$P_V = -\frac{1}{2} V_s I_2 \cos \theta = -\frac{1}{2} (12)(2.89) \cos(30 - (-138.3)) =$$

$$\boxed{P_V = +16.98W}$$

Power consumed by R

$$P_L = 0W$$

$$P_C = 0W$$

$$P_V = \frac{1}{2}V^2 / R = \frac{1}{2} \frac{12.90^2}{2}$$

Note $P_R = P_I + P_V$

$$\boxed{P_R = 41.60W}$$

Problem 9.13

Calculate the average power absorbed by the 1-Ω resistor in the network shown in Fig. P 9.13

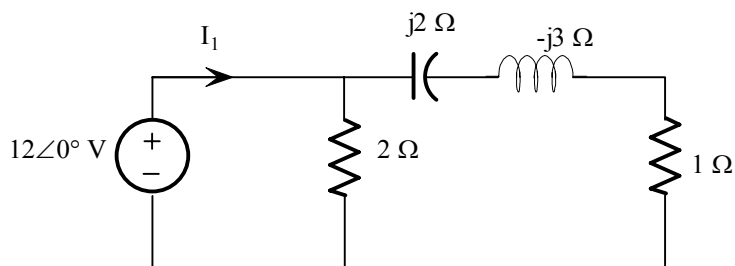
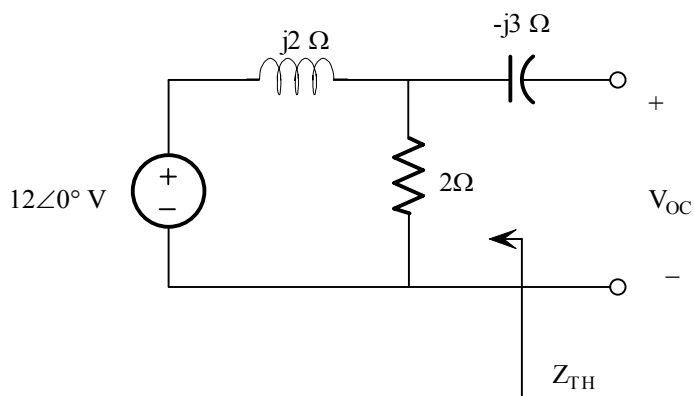

Figure P9.13

Suggested Solution

Theremin's Equation



$$V_{oc} = 12\angle 0^\circ \left[\frac{2}{2 + j2} \right]$$

$$V_{oc} = \frac{24\angle 0^\circ}{2\sqrt{2}\angle 45^\circ} \qquad V_{oc} = 8.49\angle -45^\circ \text{ V}$$

$$Z_{TH} = -j3 + (2 \parallel j2)$$

$$Z_{TH} = -j3 + \frac{j4}{2 + j2} = -j3 + \frac{4\angle 90^\circ}{2\sqrt{2}\angle 45^\circ} = -j3 + \sqrt{2}\angle 45^\circ = -j3 + 1 - j1$$

$$Z_{TH} = (1 - j2)\Omega$$

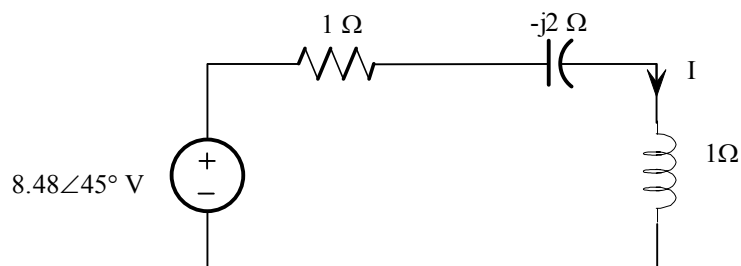

$$P_R = I^2 R / 2$$

$$I = \frac{8.49 \angle -45^\circ}{2 - j2} = \frac{8.49 \angle -45^\circ}{2\sqrt{2} \angle -45^\circ} = 3 \angle 0^\circ A$$

$$P_R = \frac{1}{2} I^2 R = \left(\frac{1}{2}\right)(3)^2(1) = \boxed{4.5W}$$

Problem 9.14

Determine the average power absorbed by the 4-Ω resistor in the network shown in Fig 9.14

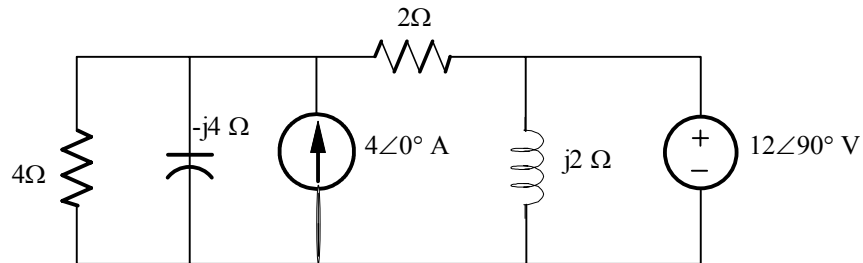
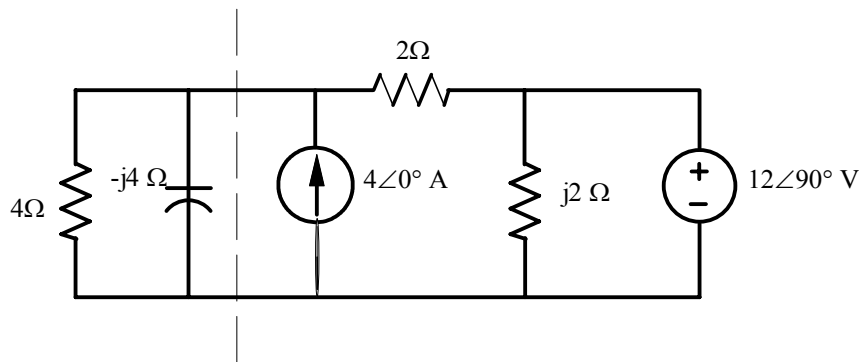
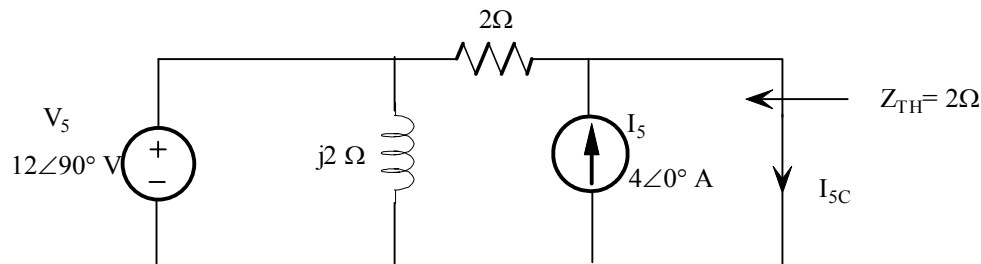

Figure P 9.14

Suggested Solution



Norton's Equivalent:



Find I_{sc} by superposition

$$I_{sc1} \text{ due to } I_s: I_{sc1} = I_s = 4\angle 0^\circ \text{ A}$$

$$I_{sc2} \text{ due to } V_5: I_{sc2} = \frac{V_5}{2} = 6\angle 90^\circ \text{ A}$$

$$I_{sc} = I_{sc1} + I_{sc2} = 4 + j6 \text{ A} = 7.21\angle 56.31^\circ$$

Norton Equation of Circuit

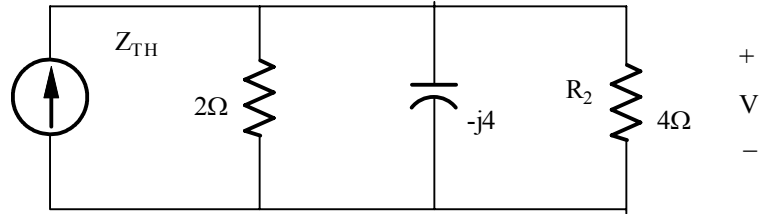

$$I_{5C} = 7.21 \angle 56.31^\circ \text{ A}$$

$$V = I_{5C} [2 // 4 // -j4] = 9.12 \angle 37.90^\circ \text{ V}$$

$$P_{4\Omega} = \frac{1}{2} \frac{|V|^2}{R_2} = 10.40 \text{ W}$$

$$\boxed{P_{4\Omega} = 10.40 \text{ W}}$$

Problem 9.15

Find the average power absorbed by each element in the network shown in Fig. P 9.15

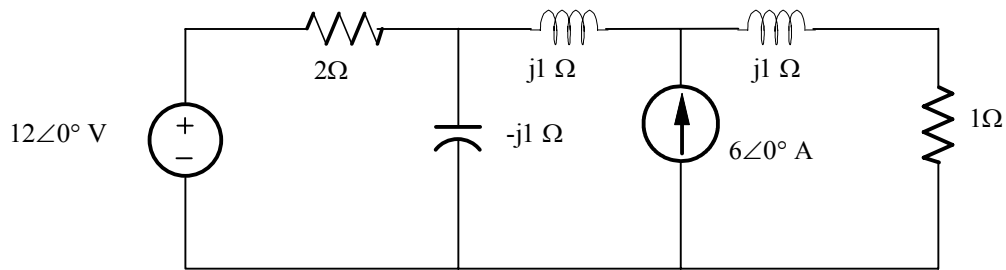
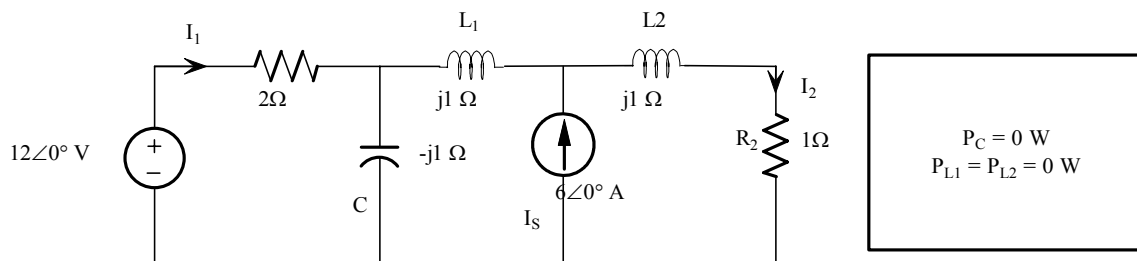

Figure P 9.15

Suggested Solution

Find I_2 using source transformation



Let $Z_1 = (2 // -j1)$

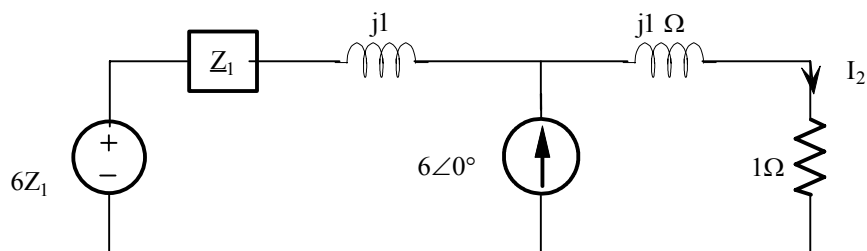

Let $Z_2 = Z_1 + j1$

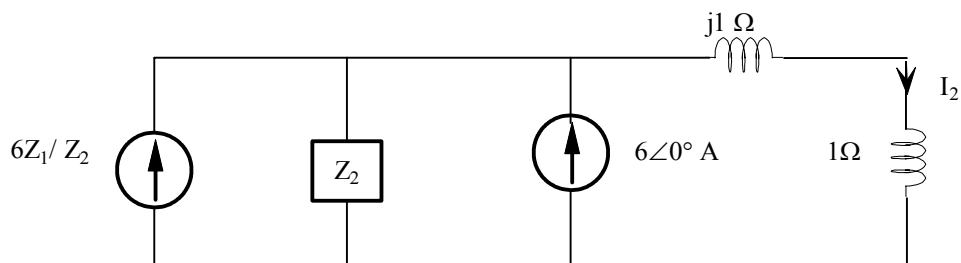

Let $I_x = 6Z_1 / Z_2 + 6\angle 0^\circ$

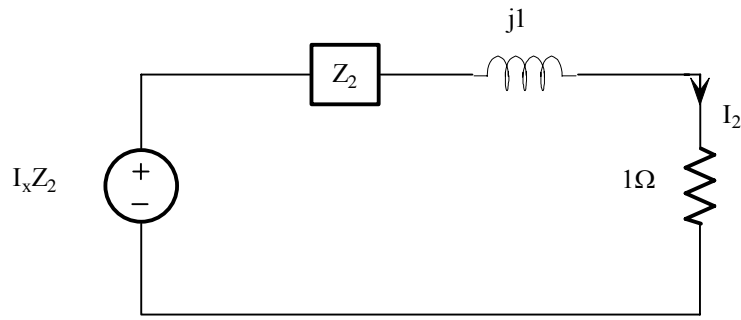

$$I_2 = \frac{I_x Z_2}{Z_2 + j1 + 1}$$

$$I_2 = 3.26 \angle -77.4^\circ A$$

Finding I_1 using source transformation:

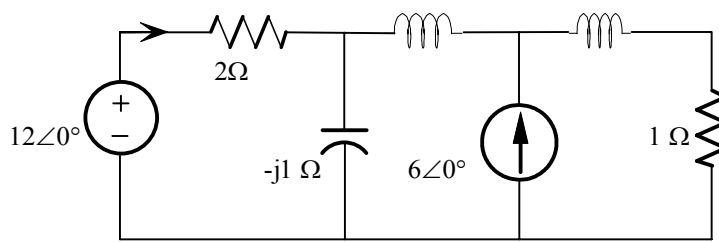

Let $Z_3 = 1 + j1 \Omega$

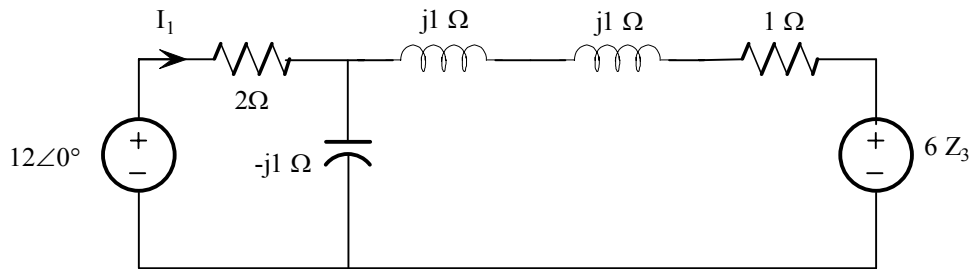

Let $Z_4 = 1 + j2 \Omega$

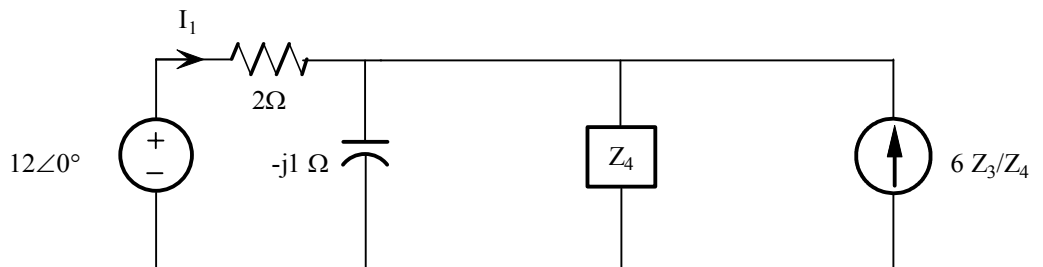

Let $Z_5 = Z_4/(-j1)$

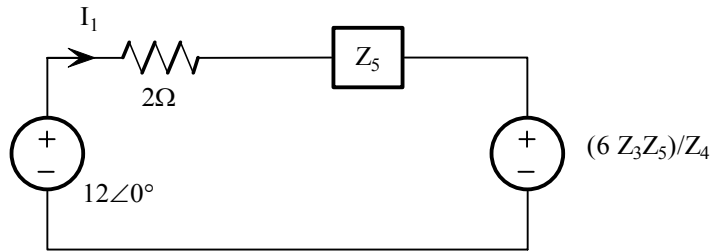

$$I_1 = \frac{12 - \frac{6Z_3Z_5}{Z_4}}{2 + Z_5}$$

$$I_1 = 4.60 \angle 57.53^\circ \text{ A}$$

Power Absorbed by Each Element

$$P_{R1} = \frac{1}{2} I_1^2 R_1 = \frac{1}{2} (4.6)^2 (2) = P_{R1} = 21.16 \text{ W}$$

$$P_{R2} = \frac{1}{2} I_2^2 R_2 = \frac{1}{2} (3.26)^2 (1) = P_{R2} = 5.31 \text{ W}$$

$$P_{VS} = \frac{1}{2} V_S I_1 \cos(0 - 57.53^\circ) = \frac{1}{2} (12)(4.6)(.54)$$

$$= 14.82 \text{ W supplied}$$

$$P_{IS} = -P_{VS} + P_{R1} + P_{R2} = 11.65 \text{ W supplied}$$

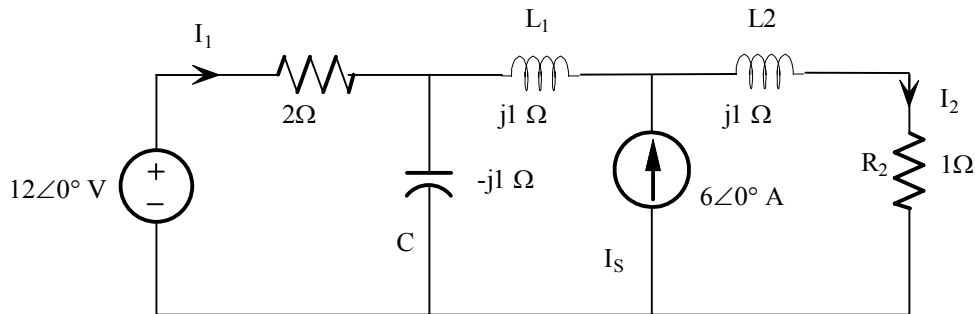

$$P_C = 0 \text{ W}$$

$$P_{L1} = P_{L2} = 0 \text{ W}$$

$$P_{R1} = \frac{1}{2} I_1^2 R_1 = \frac{1}{2} (4.6)^2 (2) = P_{R1} = 21.16 \text{ W}$$

$$P_{R2} = \frac{1}{2} I_2^2 R_2 = \frac{1}{2} (3.26)^2 (1) = P_{R2} = 5.31 \text{ W}$$

$$P_{VS} = \frac{1}{2} V_S I_1 \cos(0 - 57.53^\circ) = \frac{1}{2} (12)(4.6)(.54) = 14.82 \text{ W supplied}$$

$$P_{IS} = -P_{VS} + P_{R1} + P_{R2} = 11.65W \text{ supplied}$$

Problem 9.16

Determine the average power supplied to the network shown in Fig. P 9.16

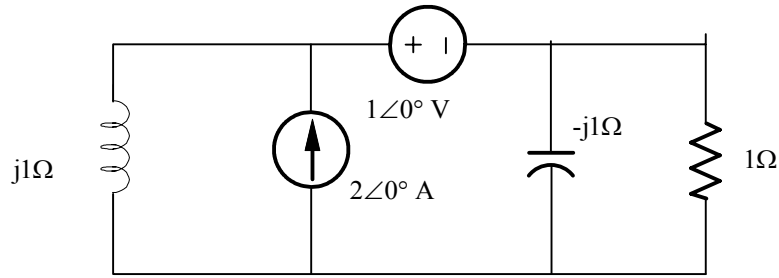
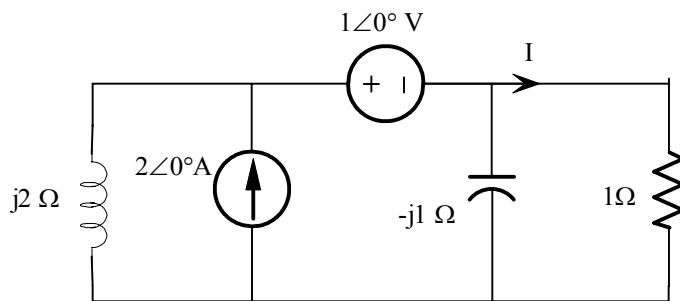
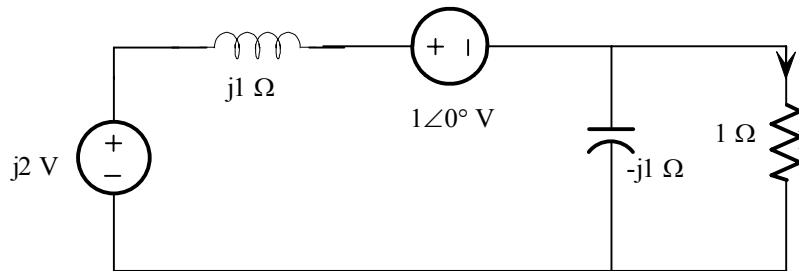

Figure P 9.16

Suggested Solution



Find I using source transformation



Let $V_{eq} = -1 + j2$ V

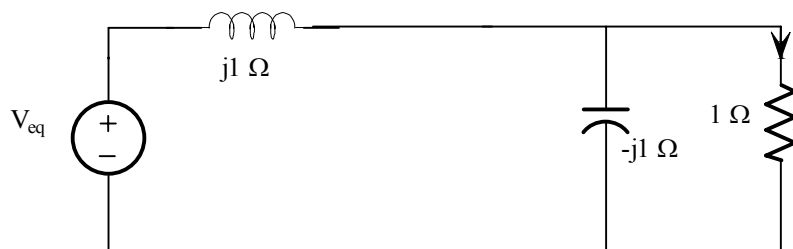

Another source transformation

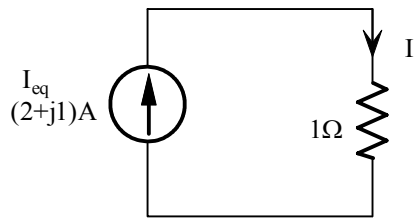
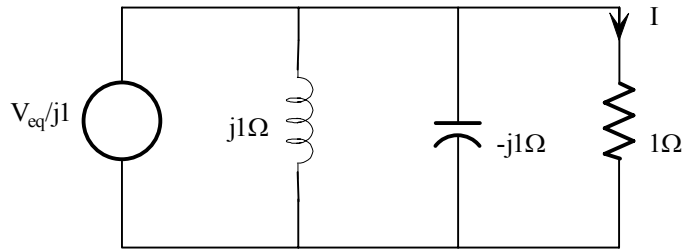

$$P_R = (1|I_{eq}|^2 R)/2$$
$$|I_{eq}| = \sqrt{5}$$

$$P_R = 2.5 \text{ W}$$

Problem 9.17

Determine the average power supplied to the network in Fig 9.17

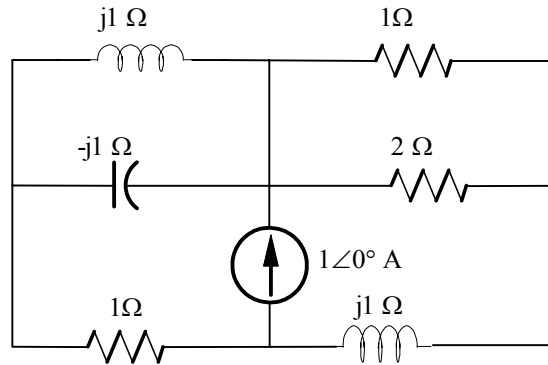
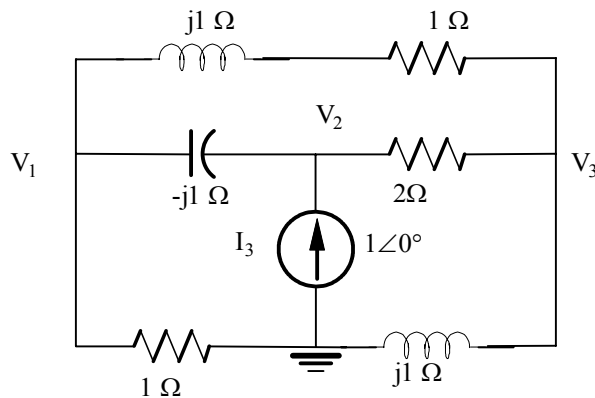

Figure P 9.17

Suggested Solution



Nodal Equations

$$\text{@ } V_2: 1 = \frac{V_2 - V_1}{-j1} + \frac{V_3 - V_2}{2}$$

$$\text{or } 2 = V_2(2 + j2) - j2V_1 - V_3 \quad (1)$$

$$\text{@ and: } 1 = \frac{V_1}{1} + \frac{V_3}{j1}$$

$$\text{or } 1 = V_1 - j1V_3 \quad (2)$$

$$V_1 = 1 + j1V_3$$

$$\text{@ } V_1: \frac{V_3 - V_1}{1 + j1} = \frac{V_2 - V_1}{-j1} + \frac{V_1}{1}$$

Solve (2) for V_1 and substitute into (1) and (3)

$$2 = V_2(2 + j2) - j2 + 2V_3 - V_3 \Rightarrow 2 + j2 = V_2(2 + j2) + V_3 \quad (4)$$

$$V_3 = 1 + j2 + V_3(-2 + j1) + V_2(1 - j1) \Rightarrow 1 + j2 = -V_2(1 - j1) + V_3(3 - j1) \quad (5)$$

Solve (4) for V_3 and substitute into (5)

$$(1 + j2) = -V_2(1 - j1) + (3 - j1)[2 + j2 - 2V_2 - j2V_2]$$

$$\text{or } V_2 = \frac{7 + j2}{9 + j7} = 0.64 \angle -21.93^\circ V$$

$$P_{is} = \frac{1}{2} |I_s| \times |V_2| \cos(-21.93 - 0) = 0.297 W$$

$$\boxed{\text{Power delivered} = 0.297 W}$$

Problem 9.18

Find the average power absorbed by the 2-Ω resistor in the circuit shown in Fig 9.18

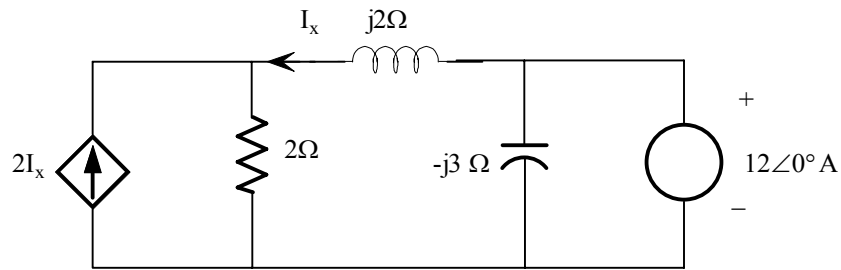
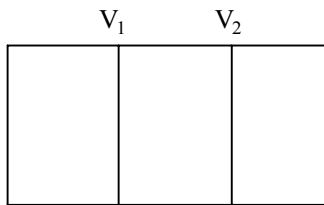

Figure P 9.18

Suggested Solution



$$\frac{V_1}{2} + \frac{V_1 - V_2}{j2} - 2I_x = 0$$

$$I_x = \frac{-(V_1 - V_2)}{j2}; \quad V_2 = 12\angle 0^\circ V$$

$$\text{Solving yields: } V_1 = \frac{18\angle -90^\circ}{1.58\angle -71.57^\circ} = 11.39\angle -18.43^\circ V$$

$$I_R = \frac{V_1}{2} = 5.7\angle -18.43^\circ A$$

$$P_R = \frac{1}{2}(5.7)^2(2) = \boxed{32.49W}$$

Problem 9.19

Given the network in Fig P 9.19 determine which elements are supplying power, which ones are absorbing power, and how much power is being supplied and absorbed.

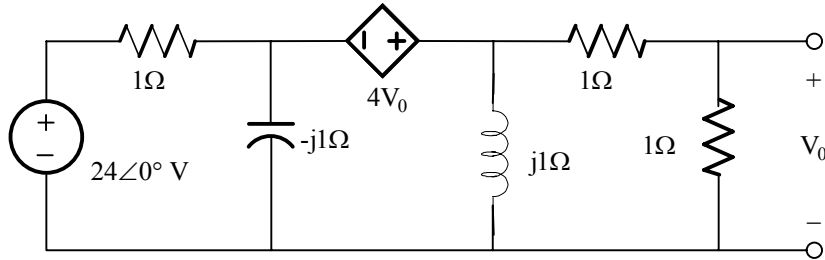
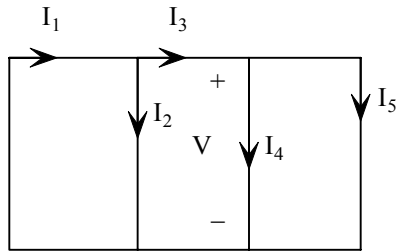

Figure P 9.19

Suggested Solution



$$\frac{V_1 - 4V_0 - 24\angle 0^\circ}{1} + \frac{V - 4V_0}{-3} + \frac{V}{j} + \frac{V}{2} = 0$$

$$\text{Where } V_0 = \frac{V}{2}$$

Solving for V yields: $V = 11.65\angle 104.04^\circ V$

$V - 4V_0 = -11.65\angle 104.04^\circ V$ SO

$$I_1 = \frac{24 + V}{1} = 24\angle 28.09^\circ A$$

$$I_2 = \frac{-V}{1\angle -90^\circ} = 11.3 + j2.83 A$$

$$I_3 = I_1 - I_2 = 13.01\angle 40.63^\circ A$$

$$I_4 = \frac{V}{1\angle 90^\circ} = 11.3 + j2.83 A$$

$$I_5 = \frac{V}{2} = -1.41 + j5.66 A$$

$$\text{Then } P_{abs} = \frac{1}{2}(24)^2(1) = 288 W$$

$$P_{2\Omega} = \frac{1}{2}(5.83)^2(2) = 34 W$$

$$\begin{aligned}P_{\text{sup}} &= P_{24|0^\circ} + P_{4V_0} \\&= \frac{1}{2}(24)(24)\cos(-28.09) \\&\quad + \frac{1}{2}(2)(11.56)(13.01)\cos(104.04 - 40.63) \\&= 67.85 + 254 = \boxed{321.85W}\end{aligned}$$

Problem 9.20

Determine the impedance Z_L for maximum average power transfer and the value of the maximum power transferred to the Z_L for the circuit shown in Fig P 9.20

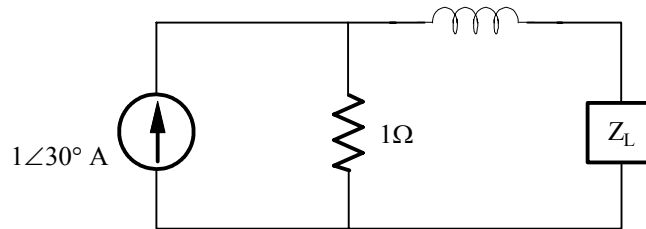
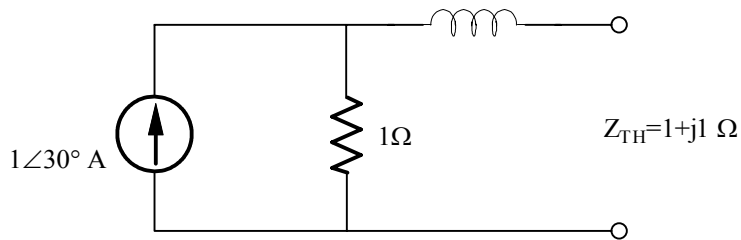

Figure P 9.20

Suggested Solution



$$Z_L = Z_{TH}^* = 1 - j1\Omega$$

$$\boxed{Z_L = 1 - j1\Omega}$$

$$V_{OC} = (1\angle 30^\circ)(1\angle 0^\circ) = 1\angle 30^\circ \text{ V}$$

$$\boxed{P_{MAX} = \frac{1}{2} \left(\frac{V_{OC}}{2R_{TH}} \right) R_L = 0.125 \text{ W}}$$

Problem 9.21

Determine the impedance Z_L for maximum average power transfer and the value of the maximum average power transferred to Z_L for the circuit shown in Fig P 9.21

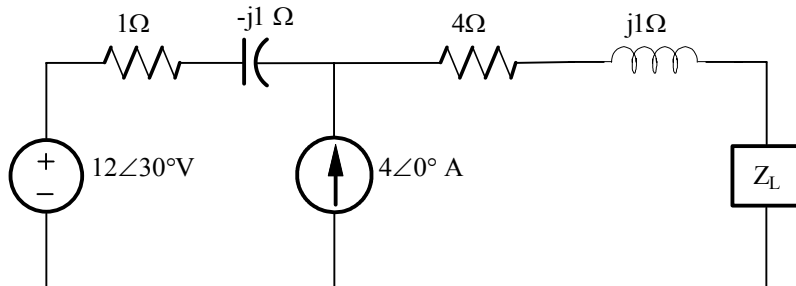
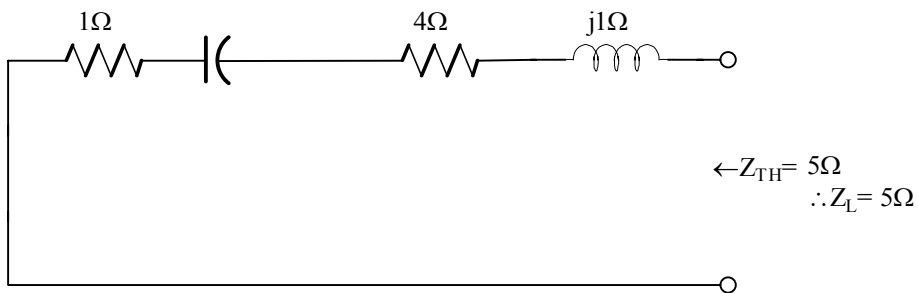
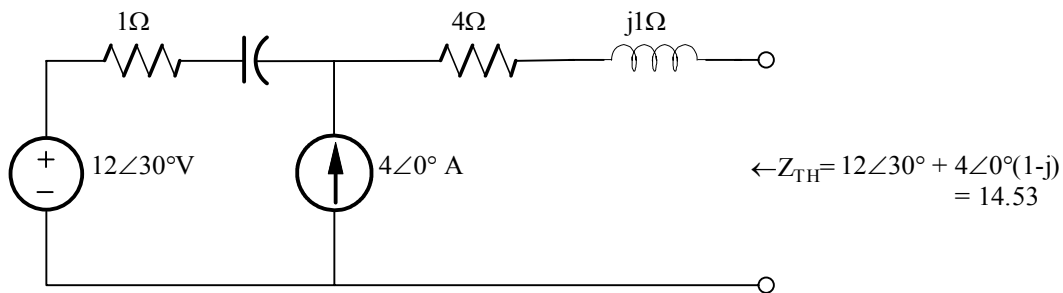

Figure P 9.21

Suggested Solution



$$P_L = \frac{1}{2} \left(\frac{14.53}{10} \right)^2 (5) = 5.28W$$

Problem 9.22

Determine the impedance Z_L for maximum average power transfer and the value of the maximum average power absorbed by the load in the network shown in Fig P 9.22

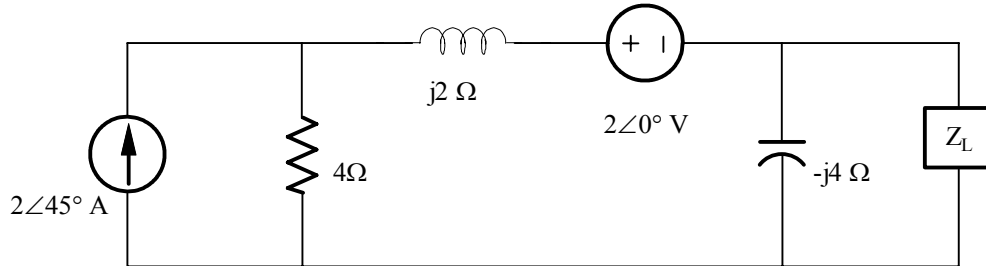
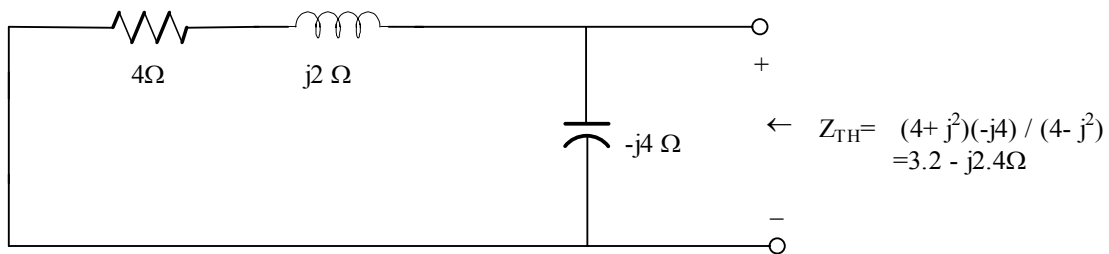
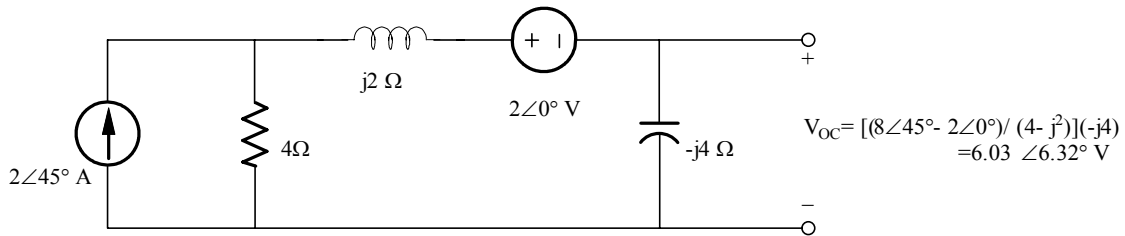

Figure P 9.22

Suggested Solution



$\therefore Z_L = 3.2 + j2.4$ and $P_L = \frac{1}{2} \left(\frac{6.03}{3.2 + 3.2} \right)^2 (3.2) = 1.42 \text{ W}$

Problem 9.23

Determine the impedance Z_L for maximum average power transfer and the value of the maximum average power absorbed by the load in the network shown in Fig P 9.23

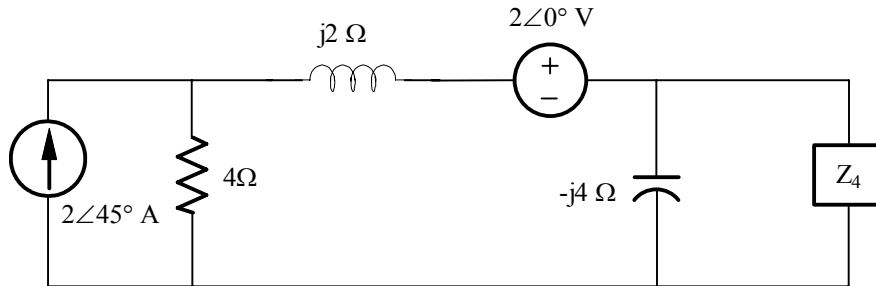
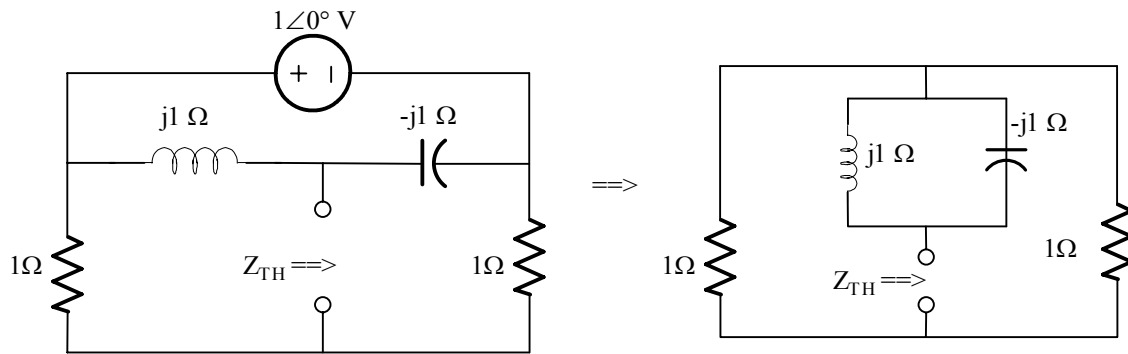

Figure P 9.23

Suggested Solution



$$Z_{TH} = [j1 // (-j1)] + (1 // 1) = \frac{1}{j1 - j1} + \frac{1}{2} = \infty$$

$$Z_{TH} = \infty$$

$$P_{Max} = 0$$

Problem 9.24

Determine the impedance Z_L for maximum average power transfer and the value of the maximum average power absorbed by the load in the network shown in Fig P 9.24

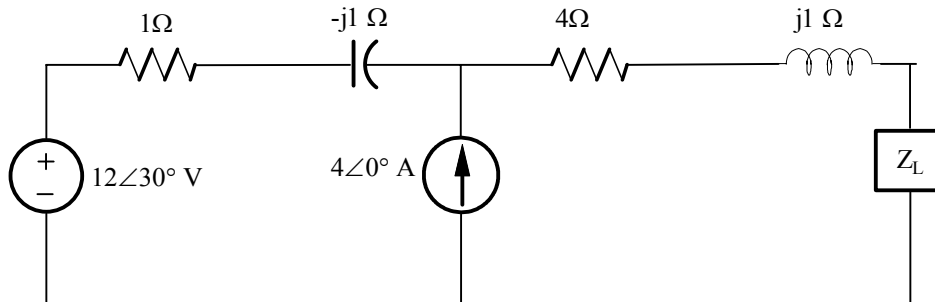
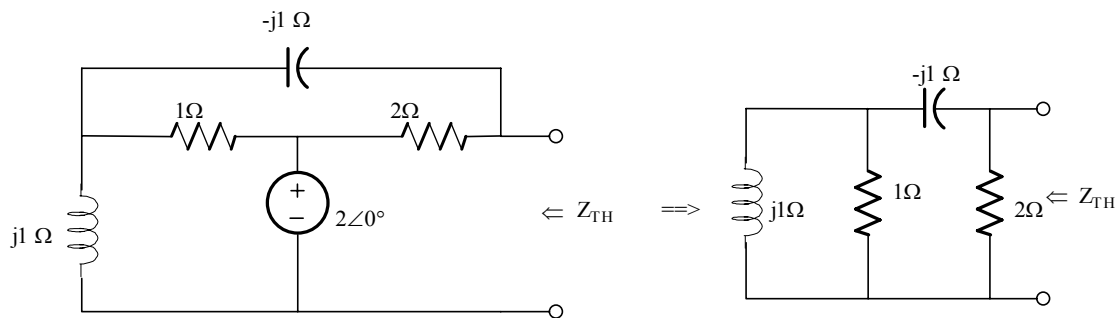

Figure P 9.24

Suggested Solution



$$Z_{TH} = [(1 // j1) - j1] // 2$$

$$= \left[\frac{j1}{1 + j1} - j1 \right] // 2 = \left(\frac{1}{1 + j1} \right) // 2 = \frac{2 / (1 + j1)}{2 + 1 / (1 + j1)} = \frac{2}{1 + 2 + j2}$$

$$Z_{TH} = \frac{2}{3 + j2} = 0.55 \angle -33.69^\circ \Omega$$

$$\boxed{Z_{TH} = 0.55 \angle -33.69^\circ \Omega}$$

Find V_{OC}

$$Z_S = j1 + 1 // (2 - j1) = 1.14 \angle 52.1^\circ \Omega$$

$$I_S = \frac{2 \angle 0^\circ}{1.14 \angle 52.1^\circ} = 1.75 \angle -52.1^\circ A$$

$$\begin{aligned}V_{OC} &= V_s - I_{2\Omega}(2\angle 0^\circ) \\ &= 2(1 - 0.56\angle -33.7^\circ) \\ &= 1.24\angle 29.7^\circ V\end{aligned}$$

$$\therefore P_{Max} = \frac{(1.24)^2}{(8)(0.46)} = 0.42W$$

Problem 9.25

Determine the impedance Z_L for maximum average power transfer and the value of the maximum average power absorbed by the load in the network shown in Fig P 9.25

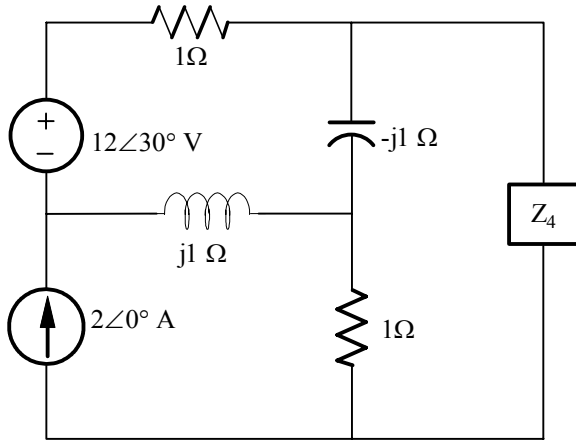
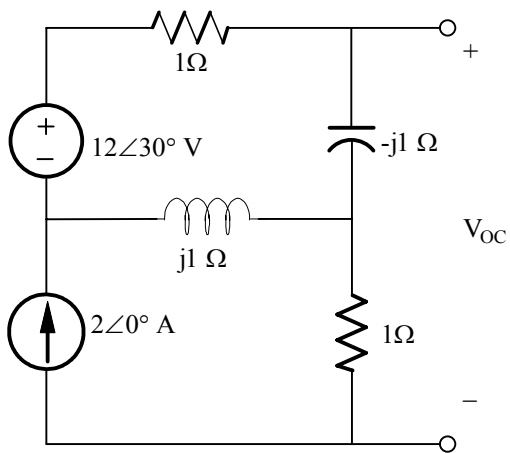

Figure P 9.25

Suggested Solution



$$12\angle 30^\circ - (1-j)I_1 - j(I_1 - I_2) = 0$$

$$I_2 = 2\angle 0^\circ A$$

$$\therefore I_1 = 13.11\angle 37.6^\circ A$$

$$V_{OC} = -jI_1 + I_2$$

$$= 14.42\angle -46.09^\circ V$$

Z_{TH} is determined from the network below

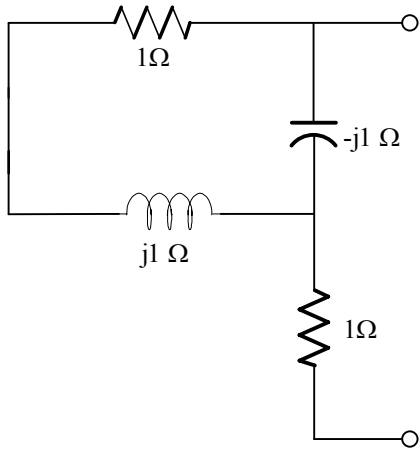

$$\leftarrow Z_{TH} = \{[(1+j)(-j)] / (1+j-j)\} - 1 = 2-j$$

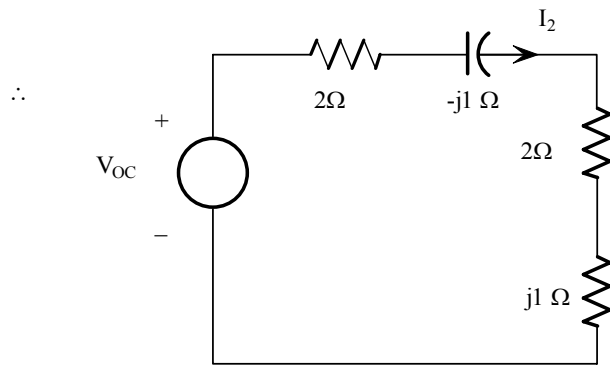

$$I_2 = (14.42 \angle -46.09^\circ) / 4$$

$$= 3.6 \angle -46.09^\circ$$

$$P_L = [1(3.6)^2(2)] / 2 = 13W$$

Problem 9.26

Repeat problem 9.24 for the network in Fig P 9.27

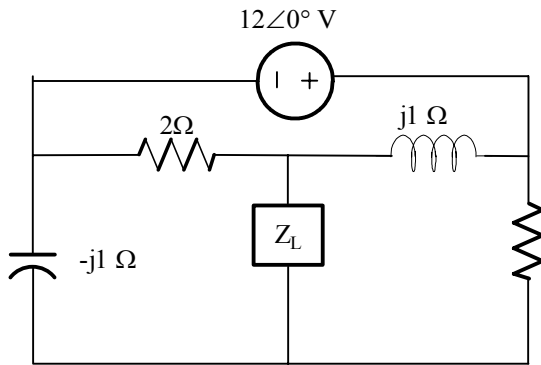
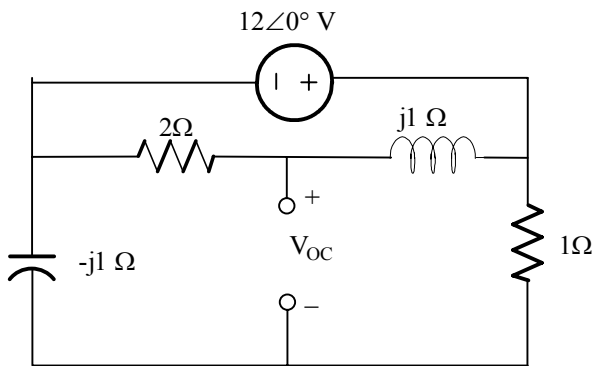
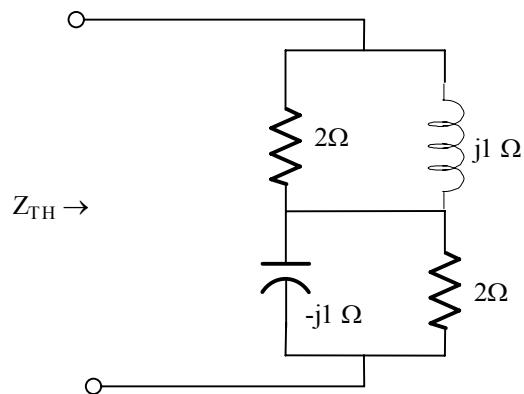

Figure 9.26

Suggested Solution



$$V_{oc} = \frac{12\angle 0^\circ}{2+j}(2) - \frac{12\angle 0^\circ}{1-j}(-j) = 3.79\angle 18.43^\circ V$$



$$Z_{TH} = \frac{2j}{2+j} + \frac{-j}{1-j}$$

$$= \frac{3}{3-j} = .9 + j.3\Omega$$

$$\therefore Z_L = .9 - j.3\Omega$$

$$P_L = \frac{1}{2} \left(\frac{3.79}{1.8} \right)^2 (.9) = 2W$$

Problem 9.27

Repeat problem 9.24 for the network in Fig P 9.27

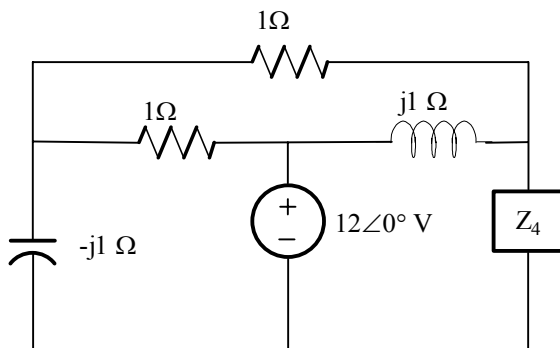

Figure 9.27

Suggested Solution

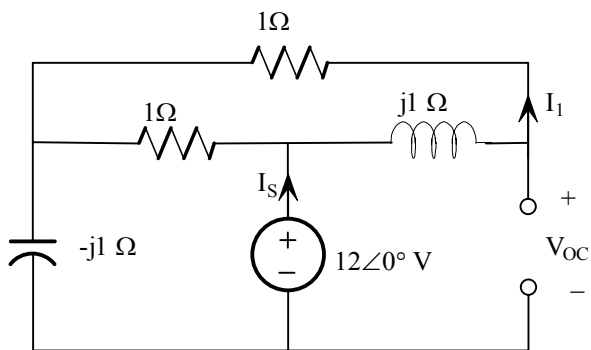
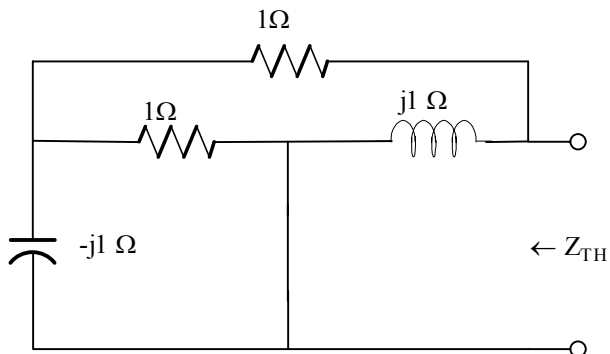

Figure 9.27

$$I_s = \frac{12\angle 0^\circ}{\frac{(1+j)(1)}{1+j+1} - j} = \frac{12(2+j)}{2-j} \text{ A}$$

$$I_1 = \frac{I_s(1)}{2+j} = \frac{12}{2-j} \text{ A}$$

$$V_{oc} = 12\angle 0^\circ - I_1(j) = 15.15\angle -18.43^\circ \text{ V}$$



$$Z_{TH} = \left(\frac{-j}{1-j} + 1 \right) // (j)$$

$$= \frac{2+j}{2-j} \Omega$$

$$P_L = \frac{1}{2} \left(\frac{15.15}{1.2} \right)^2 (.6) = 47.82W$$

Problem 9.28

Repeat problem 9.24 for the network in Fig P 9.28

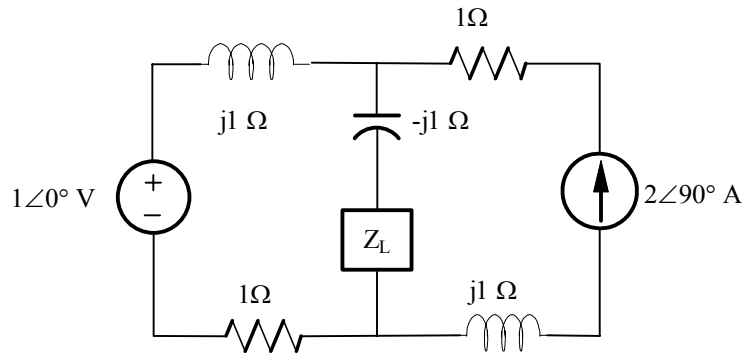
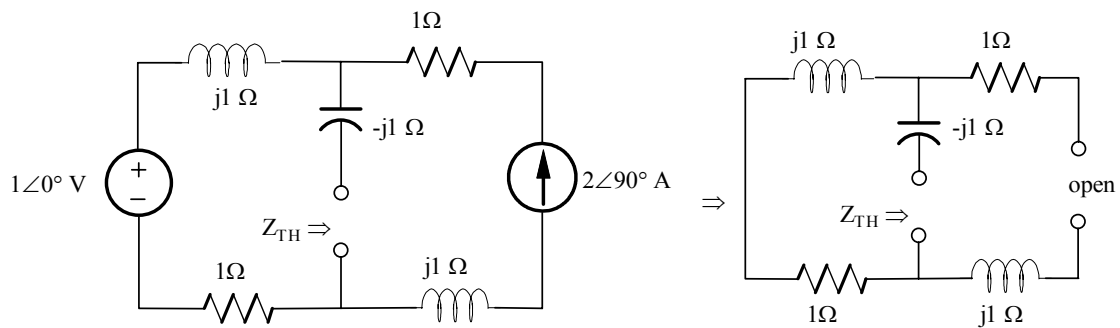

Figure P 9.28

Suggested Solution



$$Z_{TH} = -j1 + j1 + 1 = 1\Omega$$

$$Z_L = Z_{TH}^* = 1\Omega$$

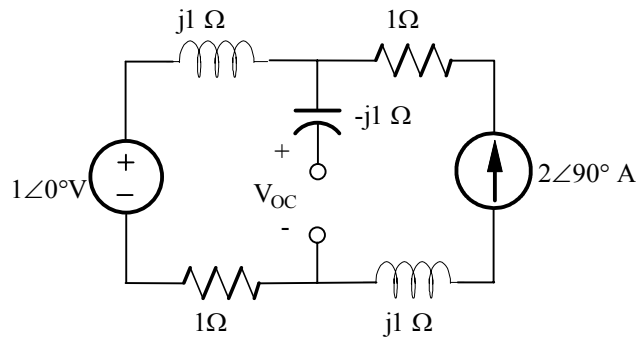

$$V_{OC} = (1 + j)(2\angle 90^\circ) + 1\angle 0^\circ$$

$$= -1 + j2 = 2.23\angle 116.57^\circ V \quad g$$

$$\therefore P_L = \frac{1}{2} \left(\frac{2.23}{2} \right)^2 (1) = 0.622W$$

Problem 9.29

Repeat problem 9.24 for the network in Fig P 9.29

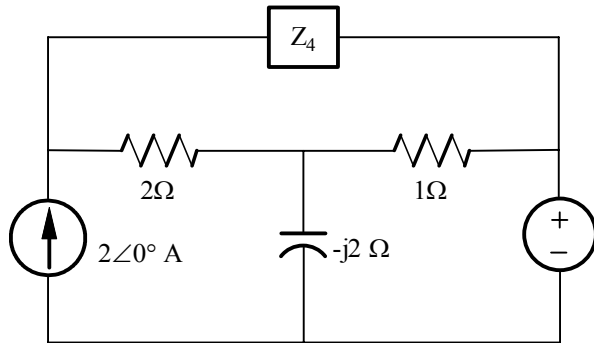
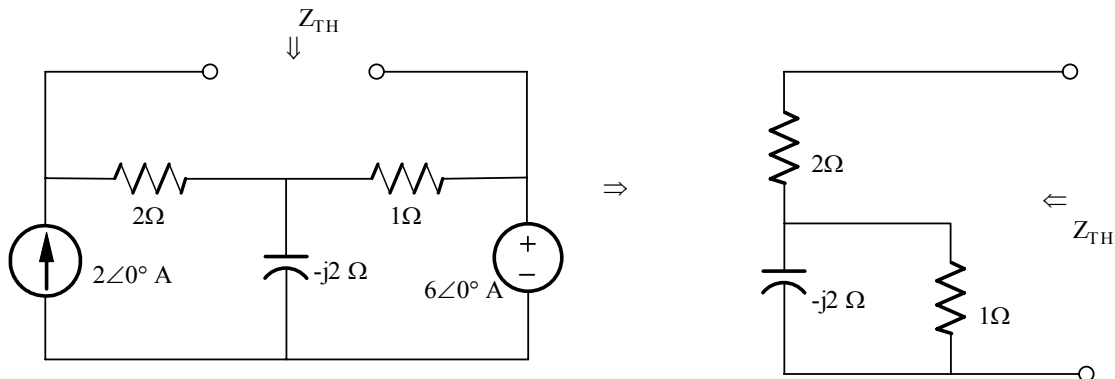

Figure P 9.29

Suggested Solution



$$Z_{TH} = 2 + (1 // -j2) = 2 - \frac{j2}{1 - j2} = \frac{2 - j6}{1 - j2} = 2.83 \angle -8.13^\circ \Omega$$

$$Z_L = Z_{TH}^* = 2.83 \angle -8.13^\circ \Omega$$

$$I_{1\Omega} = \frac{-6 - j4}{1 - j2} = 3.22 \angle -82.9^\circ A$$

$$V_{OC} = (2 \angle 0^\circ)(2) + (3.22 \angle -82.9^\circ)(1) = 5.44 \angle -36^\circ V$$

$$\therefore P_{Max} = \frac{(5.44)^2}{(8)(2.8)} = 1.32 W$$

Problem 9.30

Determine the impedance Z for maximum average power transfer and the value of the maximum average power absorbed by the load in the network shown in Fig P. 9.30

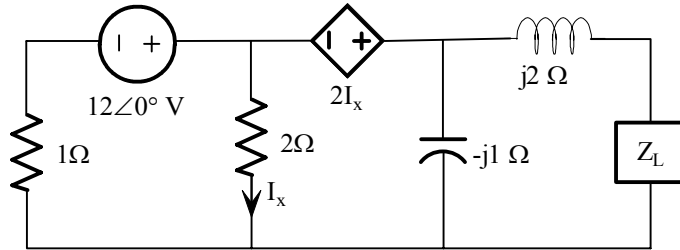
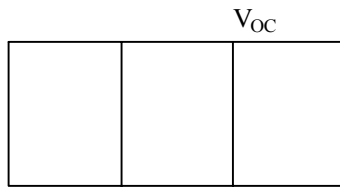

Figure P 9.30

Suggested Solution



$$\frac{V_{OC} - 2I_x - 2}{1} + \frac{V_{OC} - 2I_x}{2} + \frac{V_{OC}}{-j} = 0$$

$$\text{and } I_x = \frac{V_{OC}}{4} \quad \therefore V_{OC} = \frac{4.8}{3 + j4} = 9.6 \angle -53.13^\circ V$$

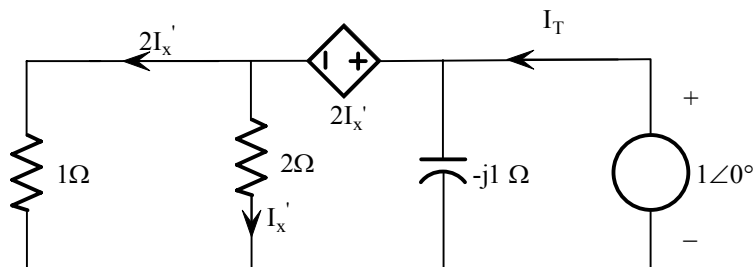

$$4I_x' = 1 \quad \therefore I_x' = 1/4$$

$$I_T = \frac{1}{-j1} + 3I_x' = \frac{3 + j4}{4}$$

$$Z_{TH} = \frac{1}{I_T} = \frac{3}{3 + j4} = .8 \angle -53.13^\circ = .48 - j.64 \quad P_L = \frac{1}{2} (10)^2 (.48) = 24W$$

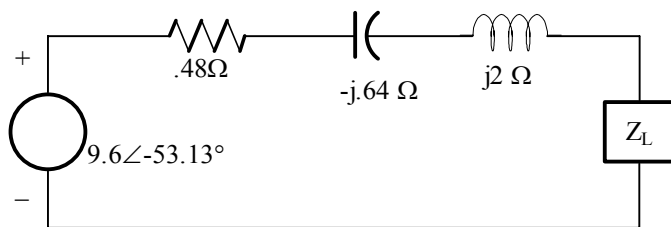

$$Z_{TH \text{ Total}} = .48 + j1.36$$

$$\therefore Z_L = .48 - j1.36$$

$$I_L = 9.6 / (.48 + .48) = 10 \text{ A}$$

$$P_L = \frac{1}{2}(10)^2(.48) = 24W$$

Problem 9.31

Determine the impedance Z_L for maximum average power transfer and the value of the maximum average power absorbed by the load in the network shown in Fig P. 9.31

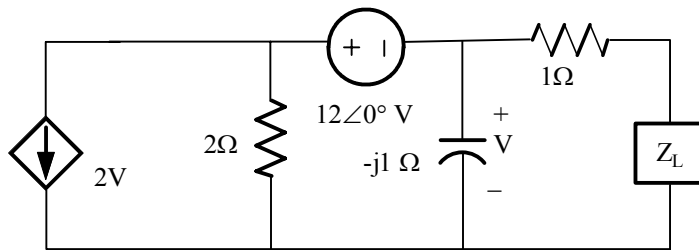
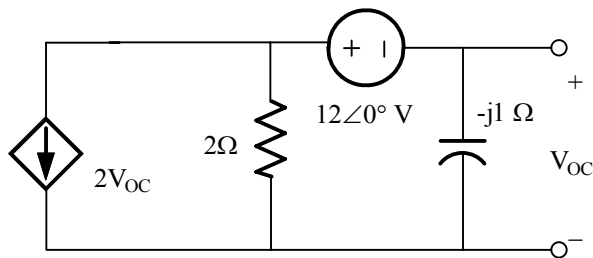

Figure P 9.31

Suggested Solution



$$\frac{V_{OC}}{-j} + \frac{V_{OC} + 12}{2} + 2V_{OC} = 0$$

$$\therefore V_{OC} = \frac{-12}{5 + 2j} = -2.23 \angle -21.8^\circ V$$

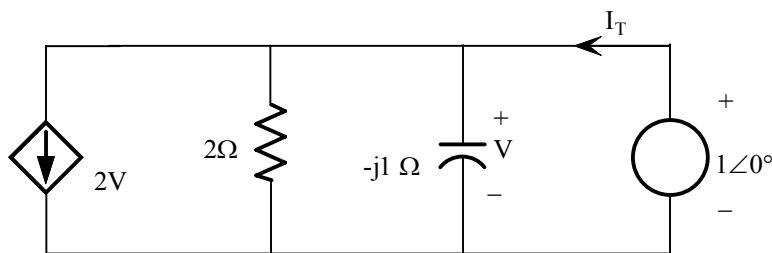

$$I_T = \frac{1}{-j} + \frac{1}{2} + 2 = j + \frac{5}{2}$$

$$Z_{TH} = \frac{1}{I_T} = \frac{1}{\frac{5}{2} + j} = .37 \angle -21.8^\circ = .34 - j.14 \Omega$$

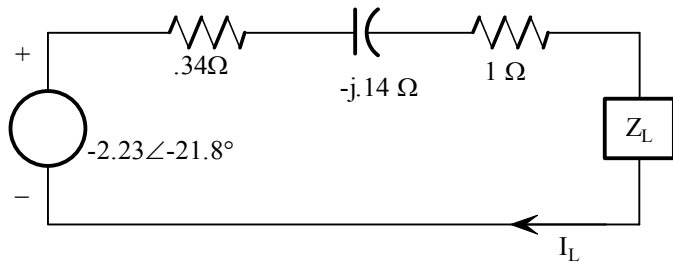

$$Z_L = 1.34 + j.14 \Omega$$

$$I_L = 2.23 / [2(1.34)] = .83 \text{ A}$$

$$P_L = 1(.83)^2(1.34) / 2 = .46 \text{ W}$$

Problem 9.32

Find the impedance Z_L for the maximum average power transfer and the value of the maximum average power transferred to Z_L for the circuit shown in Fig P 9.32

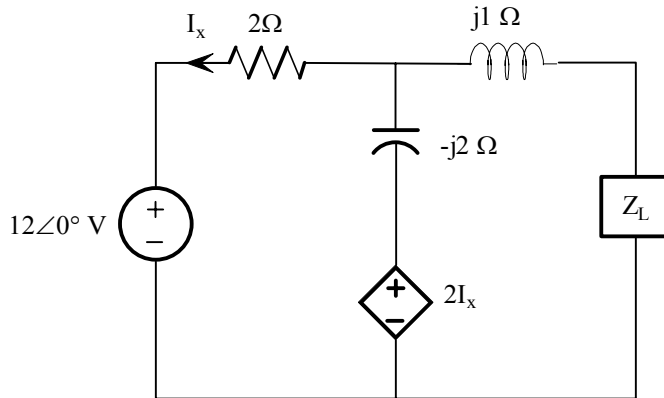
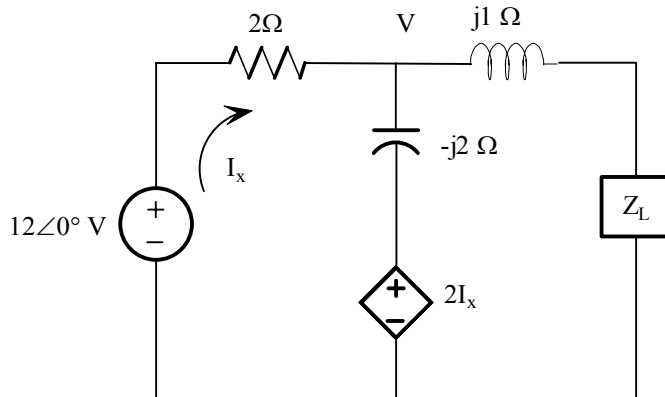

Figure P 9.32

Suggested Solution



Solving for V_{oc} :

$$\frac{12\angle 0^\circ - V}{2} = \frac{V - 2I_x}{-2j}$$

$$I_x = \frac{12 - V}{2}$$

Solving, $V = 7.6\angle -18.4^\circ = V_{oc}$

Then, we find I_{sc} :

$$\frac{12 - V}{2} + \frac{2I_x - V}{-2j} = \frac{V}{j}$$

Solving, $I_{sc} = 17.0\angle 45^\circ$

$$\text{Then, } Z_{\text{TH}} = \frac{7.6 \angle -18.4^\circ}{17.0 \angle 45^\circ} = .45 \angle -63.4^\circ = .2 - .4j$$

$$\text{So, } \boxed{Z_L = .2 + .4j}$$

$$P = \frac{1}{2} (17)^2 (.2) = \boxed{28.9W}$$

Problem 9.33

Determine the impedance Z_L for the maximum average power transfer and the value of the maximum average power absorbed by the load in the network shown in Fig P 9.33

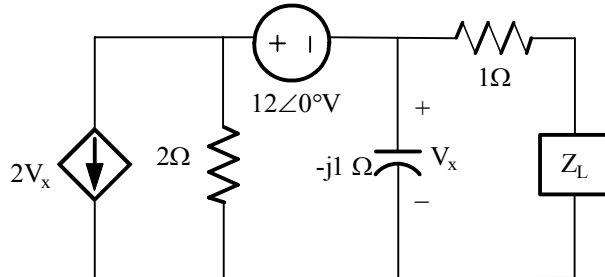
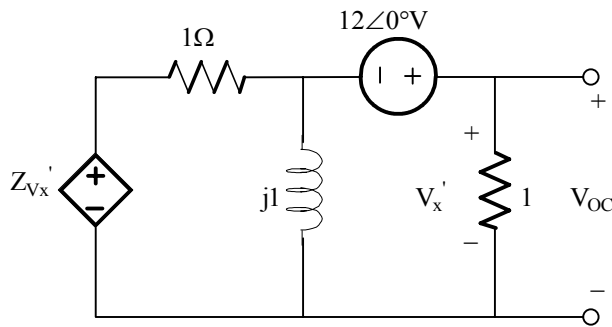

Figure P 9.33

Suggested Solution



$$\frac{V_{OC} - 12 - 2V_{OC}}{1} - \frac{V_{OC} - 12}{j1} + \frac{V_{OC}}{1} = 0$$

$$V_{OC} = 12 + j12V$$

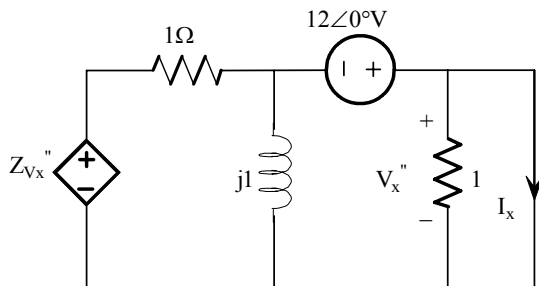

$$V_x'' = 0$$

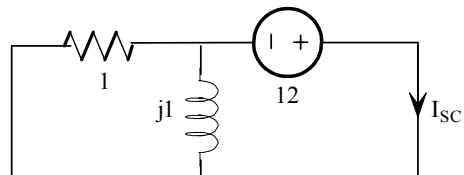

$$I_{SC} = \frac{12}{\frac{j}{1+j}} = \frac{12(1+j)}{j} = \frac{12 + j12}{j}$$

$$Z_{TH} = \frac{V_{OC}}{I_{SC}} = j1\Omega \quad \text{Then}$$

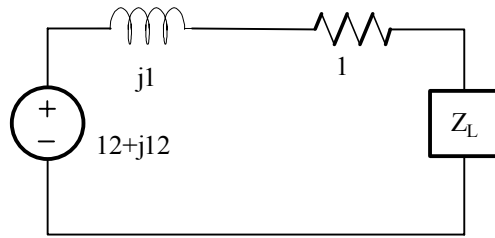

$$Z_L = 1 - j \Omega$$

$$I_L = \frac{12 + j12}{1 + j + 1 - j} = 8.4853 \angle 45^\circ$$

$$\text{And } P_{load} = \frac{1}{2} (8.4853)^2 (1) = 36W$$

Problem 9.34

Compute the rms value of the voltage given by the waveform shown in Fig P 9.34

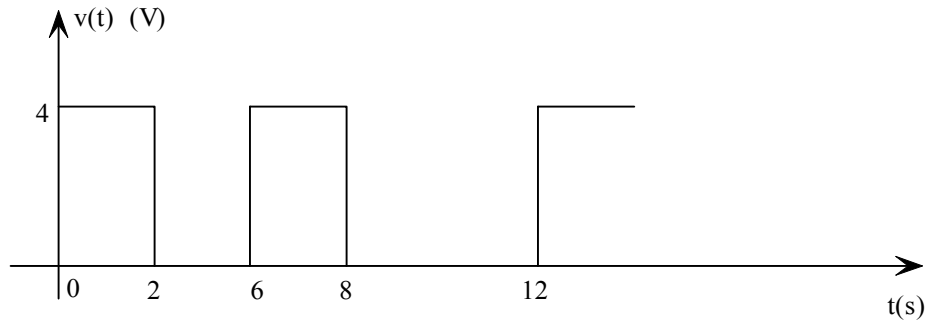

Figure P 9.34

Suggested Solution

$$V_{RMS} = \sqrt{\frac{1 \int_0^T v^2(t) dt}{T}} \quad \text{where } v(t) = \begin{cases} 4 & 0 \leq t \leq 2 \\ 0 & 2 \leq t \leq 6 \end{cases} \quad \& \quad T = 6$$

$$V_{RMS} = \sqrt{\frac{1 \left[\int_0^2 4^2 dt \right]}{6}} = \sqrt{\frac{16(t \Big|_0^2)}{6}} = \sqrt{\frac{32}{6}}$$

$$\boxed{V_{RMS} = 2.31 V_{RMS}}$$

$$V_{RMS} = \sqrt{\frac{1 \int_0^T v^2(t) dt}{T}} \quad \text{where } v(t) = \begin{cases} 4 & 0 \leq t \leq 2 \\ 0 & 2 \leq t \leq 6 \end{cases} \quad \& \quad T = 6$$

$$V_{RMS} = \sqrt{\frac{1 \left[\int_0^2 4^2 dt \right]}{6}} = \sqrt{\frac{16(t \Big|_0^2)}{6}} = \sqrt{\frac{32}{6}}$$

$$\boxed{V_{RMS} = 2.31 V_{RMS}}$$

Problem 9.35

Find the rms values of the waveform shown in Fig P 9.35

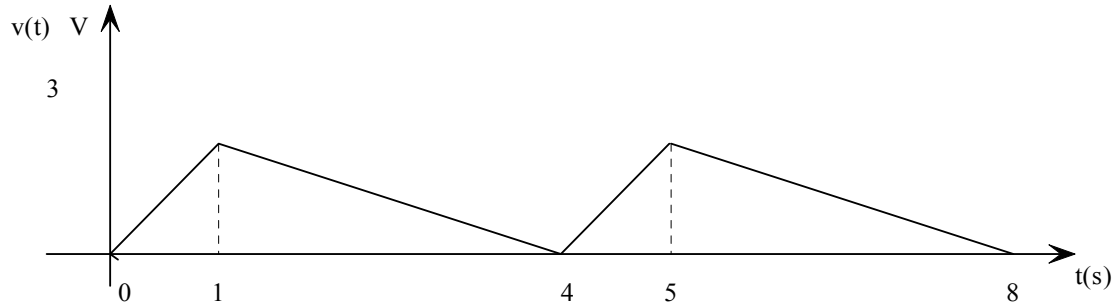

Figure P 9.35

Suggested Solution

$$V_{rms} = \left[\frac{1}{4} \left(\int_0^1 (3t)^2 dt + \int_1^4 (4-t)^2 dt \right) \right]^{\frac{1}{2}}$$

$$= \left[\frac{1}{4} \left(3t^3 \Big|_0^1 + \left(16t - 4t^2 + \frac{t^3}{3} \right) \Big|_1^4 \right) \right]^{\frac{1}{2}}$$

$$= \sqrt{3}V$$

Problem 9.36

Calculate the rms value of the waveform shown in Fig P 9.36

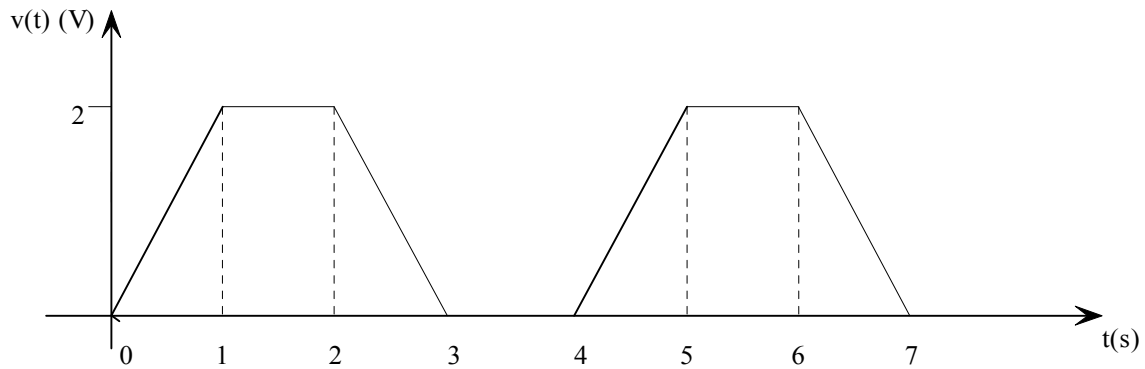

Figure P 9.36

Suggested Solution

$$\begin{aligned} I_{rms} &= \sqrt{\frac{1[\int_0^1 (2t)^2 dt + \int_1^2 2^2 dt + \int_2^3 (6-2t)^2 dt]}{4}} \\ &= \sqrt{\frac{1[\frac{4}{3}t^3]_0^1 + 4 + (36t - 12t^2 + \frac{4}{3}t^3)]_2^3}{4}} \\ &= \boxed{1.29A} \end{aligned}$$

Problem 9.37

Calculate the rms value of the waveform shown in Fig P 9.37

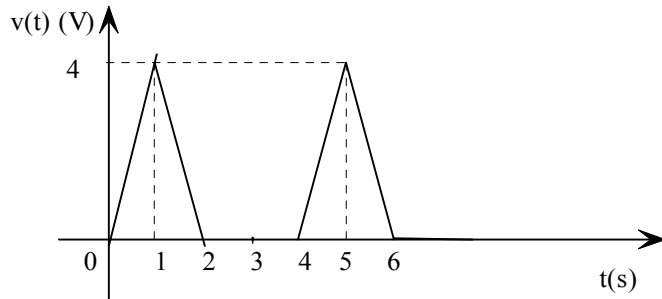

Figure P 9.37

Suggested Solution

$$\begin{aligned} I_{rms} &= \sqrt{\frac{1}{4} \left[\int_0^1 (4t)^2 dt + \int_1^2 (8-4t)^2 dt \right]} \\ &= \sqrt{\frac{1}{4} \left(\frac{16}{3} + \left(64t - \frac{64t^2}{2} + \frac{16t^3}{3} \right) \Big|_1^2 \right)} = \boxed{1.63V} \end{aligned}$$

Problem 9.38

The current waveform in Fig P 9.38 is flowing through a $5\text{-}\Omega$ resistor. Find the average power absorbed by the resistor.

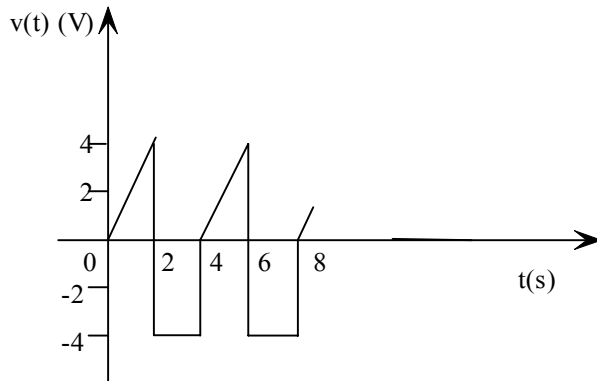

Figure P 9.38

Suggested Solution

A $5\text{-}\Omega$ resistor passes current shown in Fig P 9.38

$$I_{rms} = \sqrt{\frac{1}{4} \left[\int_0^2 (2t)^2 dt + \int_2^4 -4^2 dt \right]}$$

$$= \sqrt{\frac{1}{4} \left(\frac{4}{3} + 3 \Big|_0^2 + 16t \Big|_2^4 \right)} = 3.27 A$$

Then, $P = (3.27)^2(5) = 53.3W$

Problem 9.39

Calculate the rms value of the waveform shown in Fig P 9.39

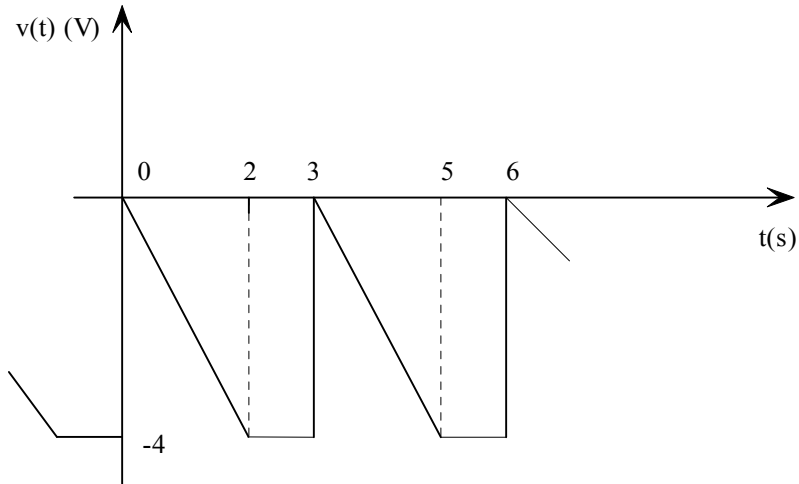

Figure P 9.39

Suggested Solution

Find rms value.

$$\begin{aligned} V_{rms} &= \sqrt{\frac{1}{3} \left[\int_0^2 (-2t)^2 dt + \int_2^3 -4^2 dt \right]} \\ &= \sqrt{\frac{1}{3} \left(\frac{4}{3} t^3 \Big|_0^2 + 16t \Big|_2^3 \right)} = \boxed{2.98V} \end{aligned}$$

Problem 9.40

Compute the rms value of the waveform in Fig 9.40

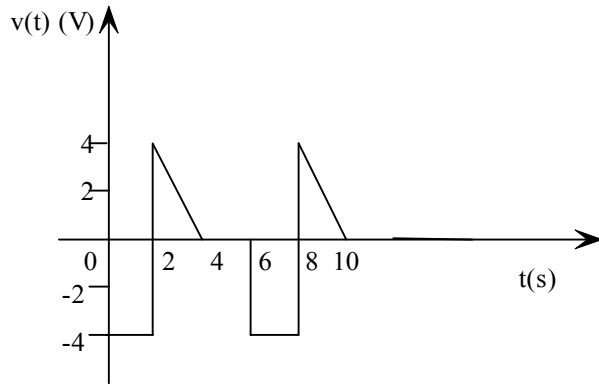

Figure P 9.40

Suggested Solution

Find rms value

$$\begin{aligned} V_{rms} &= \sqrt{\frac{1}{6} \left[\int_0^2 -4^2 dt + \int_2^4 (8-2t)^2 dt \right]} \\ &= \sqrt{\frac{1}{6} \left[16t \Big|_0^2 + \left(64t - 16t^2 + \frac{4}{3}t^3 \right) \Big|_2^4 \right]} \\ &= \sqrt{\frac{1}{6} \frac{128}{3}} = \boxed{2.67V} \end{aligned}$$

Problem 9.41

Calculate the rms value of the waveform shown in Fig 9.41

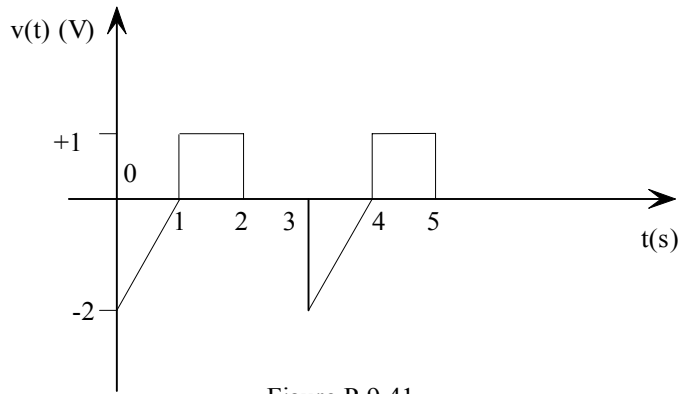

Suggested Solution

Find rms value:

$$\begin{aligned} I_{rms} &= \sqrt{\frac{1}{3} \left[\int_0^1 (2t-2)^2 dt + \int_1^2 1^2 dt \right]} \\ &= \sqrt{\frac{1}{3} \left[\left(\frac{4}{3}t^3 - \frac{8t^2}{2} + 4t \right) \Big|_0^1 + t \Big|_1^2 \right]} \\ &= \sqrt{\frac{1}{3} \left(\frac{7}{3} \right)} = \boxed{0.88A} \end{aligned}$$

Problem 9.42

Calculate the rms value of the waveform shown in Fig 9.42

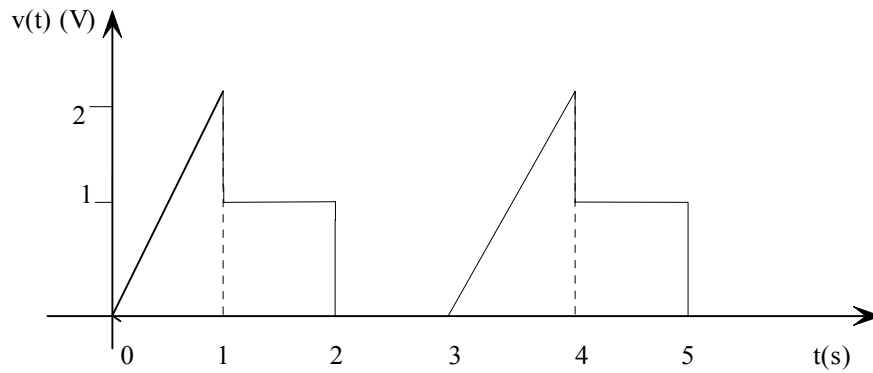

Figure P 9.42

Suggested Solution

Find rms value:

$$I_{rms} = \sqrt{\frac{1}{3} \left[\int_0^1 (2t)^2 dt + \int_1^2 1^2 dt \right]}$$
$$= \sqrt{\frac{1}{3 \left(\frac{4}{3} t^3 \Big|_0^1 + t \Big|_1^2 \right)}} = \boxed{0.88A}$$

Problem 9.43

An industrial load consumes 100 kW at 0.8 pf lagging. If an ammeter in the transmission line indicates that the load current is 284 A rms, find the load voltage.

Suggested Solution

A load consumes 100 kW at pf=.8 lag

$I_{load} = 284 A$ rms. Find load voltage.

$$V_{rms} = \frac{100,000W}{(.8)(284A)} = \boxed{440V}$$

Problem 9.44

An industrial load that consumes 80 kW is supplied by the power company through a transmission line with 0.1Ω resistance, with 84kW. If the voltage at the load is 440 Vrms, find the power factor at the load.

Suggested Solution

A load consumes 80 kW. 1 B source supplies 84 kW. $R_{line} = 0.1\Omega, V_{load} = 440V_{rms}$. And load p.f.

$$P_S = P_{load} + I^2 R_{line} = 84kW = I^2 (.1) + 80kW$$

$$\text{Yeilds } I = 200A_{rms}. \text{ Then, PF} = \frac{80,000}{(440)(200)} = \boxed{.91Lag}$$

Problem 9.45

The power company supplies 80 kW to an industrial load. The load draws 220 A rms from the transmission line. If the load voltage is 440 V rms and the load power factor is 0.8 lagging, find the losses in the transmission line.

Suggested Solution

$P_S = 80kW$, $I_L = 220A_{rms}$, $V_{load} = 440V_{rms}$ with p.f.= 0.8 lag. Find line loss.

$$P_S = V_{rms} I_{rms} pf = (440)(220)(.8) = 72.44kW$$

$$P_{line} = P_S - P_L = 80k - 72.44k = \boxed{2.56kW}$$

Problem 9.46

An industrial plant with an inductive load consumes 10 kW of power from a 220 V rms line. If the load power factor is 0.8, what is the angle by which the load voltage leads the load current?

Suggested Solution

$$\theta = \cos^{-1} 0.8 = 36.87^\circ$$

Problem 9.47

The power company must generate 100 kW in order to supply an industrial load with 94 kW through a transmission line with 0.09Ω resistance. If the load power factor is 0.83 lagging, find the load voltage.

Suggested Solution

$$P_S = I^2 R_{line} + P_L$$

$$100kW = I^2 (.09) + 94kW$$

$$I^2 = \frac{600}{.09}$$

$$\therefore I_{rms} = 258.2A$$

$$V_{rms} = \frac{P_L}{I_{rms} Pf} = \frac{94000}{(258.2)(.83)} = \boxed{440V}$$

Problem 9.48

An industrial load operates at 30 kW, 0.8 pf lagging. The load voltage is $220\angle 0^\circ$ V rms. The real and reactive power losses in the transmission-line feeder are 1.8 kW and 2.4 kvar, respectively. Find the impedance of the transmission line and the input voltage to the line.

Suggested Solution

$$P_{load} = 30kW \text{ as pf} = .8 \text{ lag. } V_L = 220\angle 0^\circ V_{rms}$$

$$P_{line} = 1.8kW + 2.4k \text{ var. Find } R_{line}, V_S$$

$$I_L = \frac{P_L}{V_{rms} \cdot pf} = \frac{30000}{220 \times .8} = 170.45 \angle \cos^{-1} .8$$
$$= 170.45 \angle -36.9^\circ$$

$$\text{Then, } R_{line} = \frac{P}{I^2}$$

$$R_{line} = \frac{1800}{170.45^2} = .062\Omega$$

$$L_{line} = \frac{P}{I^2} = \frac{2400}{170.45^2} = .083j$$

$$Z_{line} = .062 + .083j$$

$$V_S = V_{load} + I_L Z_L = 220\angle 0^\circ + (170.45 \angle -36.9^\circ) Z_L$$

$$= 237 \angle 1.19^\circ$$

Problem 9.49

A transmission line with impedance $0.08 - j 0.25 \Omega$ is used to deliver power to a load. The load is inductive and the load voltage is $220 \angle 0^\circ$ V rms at 60 Hz. If the load requires

Suggested Solution

$$Z_{line} = .08 + j.25$$

$$V_{Load} = 220 \angle 0^\circ \text{ at } 60 \text{ Hz}$$

$$P_{load} = 12kW \quad P_{Line} = 560kW \quad \text{Find pf at load.}$$

$$P_{line} = 560 = I^2(.08) \text{ yeilds } I = 83.67 A$$

$$P_{load} = IV \cos \theta = 12kW = (220)(83.67) \cos \theta$$

$$\theta = \cos^{-1} \frac{12000}{(220)(83.67)} = \boxed{.65 = pf \text{ lagging}}$$

Problem 9.50

Find the source voltage in the network shown in Fig P 9.50

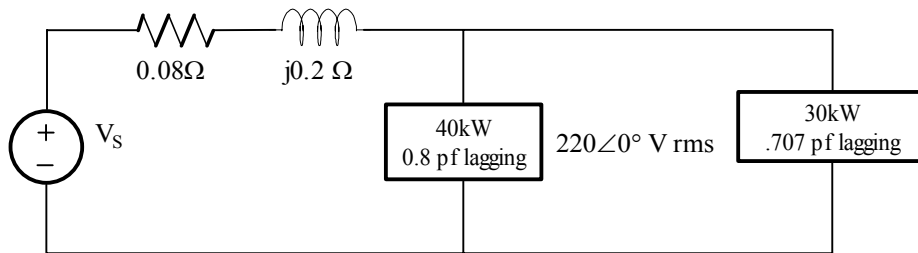

Figure P 9.50

Suggested Solution

$$I_{L_1} = \frac{40000}{(220)(.8)}$$

$$= 227.27 A$$

$$I_{L_2} = \frac{30000}{(220)(.707)}$$

$$= 177.1 A$$

$$\theta_1 = \cos^{-1}(.8) = 36.87^\circ \quad \theta_2 = \cos^{-1}(.707) = 45^\circ$$

$$I_L = I_{L_1} + I_{L_2} = 227.27 \angle -36.87^\circ + 177.1 \angle -45^\circ$$

$$= 403 \angle -40.43^\circ A$$

$$V_{line} = I_L (.8 + j2) = (403.37 \angle -40.43^\circ)(.22 \angle 68.2^\circ)$$

$$= 88.74 \angle 27.77^\circ V$$

$$V_S = V_{line} + 220 \angle 0^\circ = \boxed{301.37 \angle 7.89^\circ}$$

Problem 9.51

Given the network in Fig P 9.51, compute the input source voltage and the input power factor.

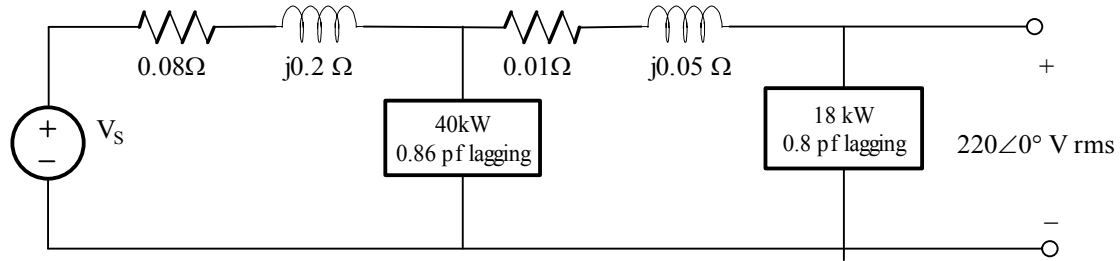

Figure P 9.51

Suggested Solution

$$\theta_L = \cos^{-1} .8 = 36.87^\circ$$

$$I_{L_2} = \frac{80000}{(220)(.8)} = 102.27 A$$

$$I_{L_2} = 102.27 \angle -36.87^\circ A$$

$$V_{L_1} = (.01 + j.05)(102.27 \angle -36.87^\circ) + 220 \angle 0^\circ$$

$$= 223.91 \angle .89^\circ V$$

$$\theta_1 = \cos^{-1} .86 = 30.68^\circ \text{lagging}$$

$$I_{L_1} = \frac{40000}{(223.91)(.86)} = 207.72 A$$

$$I_{L_1} = 207.72 \angle (-30.68^\circ + .89^\circ) = 207.72 \angle -29.79^\circ A$$

$$I_L = I_{L_1} + I_{L_2} = 207.72 \angle -29.79^\circ + 102.27 \angle -36.87^\circ A$$

$$= 309.47 \angle -32.12^\circ A$$

$$V_S = (309.47 \angle -32.12^\circ)(.08 + j.2) + 223.91 \angle .89^\circ$$

$$= 281.02 \angle 8.75^\circ V$$

$$\theta_S = \theta_{V_S} - \theta_{i_S} = 8.75^\circ - (-32.12^\circ) = 40.87^\circ$$

$$P_{\text{Source}} = \cos(40.87^\circ) = \boxed{.756 \text{lagging}}$$

$$\theta_L = \cos^{-1}.8 = 36.87^\circ$$

$$I_{L_2} = \frac{80000}{(220)(.8)} = 102.27 A$$

$$I_{L_2} = 102.27 \angle -36.87^\circ A$$

$$V_{L_1} = (.01 + j.05)(102.27 \angle -36.87^\circ) + 220 \angle 0^\circ \\ = 223.91 \angle .89^\circ V$$

$$\theta_1 = \cos^{-1}.86 = 30.68^\circ \text{lagging}$$

$$I_{L_1} = \frac{40000}{(223.91)(.86)} = 207.72 A$$

$$I_{L_1} = 207.72 \angle (-30.68^\circ + .89^\circ) = 207.72 \angle -29.79^\circ A$$

$$I_L = I_{L_1} + I_{L_2} = 207.72 \angle -29.79^\circ + 102.27 \angle -36.87^\circ A \\ = 309.47 \angle -32.12^\circ A$$

$$V_S = (309.47 \angle -32.12^\circ)(.08 + j.2) + 223.91 \angle .89^\circ \\ = 281.02 \angle 8.75^\circ V$$

$$\theta_S = \theta_{V_S} - \theta_{i_S} = 8.75^\circ - (-32.12^\circ) = 40.87^\circ$$

$$P_{\text{Source}} = \cos(40.87^\circ) = \boxed{.756 \text{lagging}}$$

Problem 9.52

Given the network in Fig P 9.52, determine the input voltage V_s .

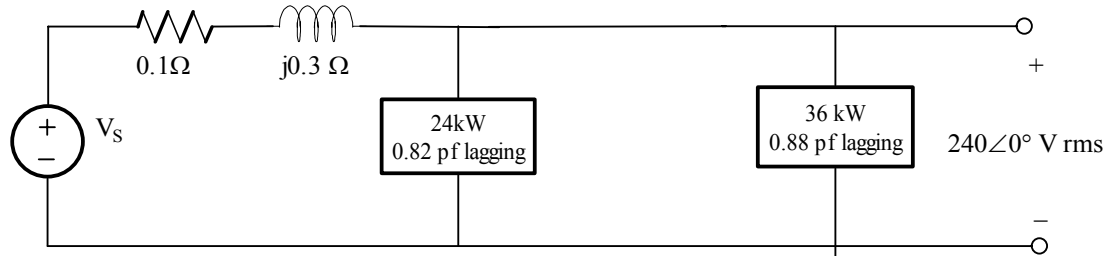
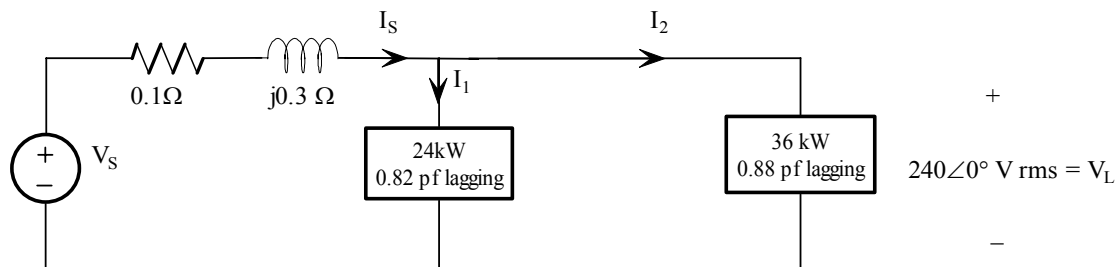

Figure P 9.52

Suggested Solution



$$V_s = V_L + I_s (.01 + j.03)$$

$$I_s = I_1 + I_2$$

$$\text{Find } I_1: I_1 = \frac{P_1}{|V_L| (pf_1)} \angle -\cos^{-1}(.82) = 121.95 \angle -34.92^\circ A_{rms}$$

$$\text{Find } I_2: I_2 = \frac{P_2}{|V_L| (pf_2)} \angle -\cos^{-1}(.88) = 170.45 \angle -28.36^\circ A_{rms}$$

$$\text{Find } I_s: I_s = I_1 + I_2 = 250 - j150.76$$

$$I_s = 291.94 \angle -31.09^\circ A_{rms}$$

$$\text{Find } V_s: V_s = V_L + I_s (0.1 + j0.3) = V_L + I_s [0.316 \angle 71.57^\circ]$$

$$V_s = 240 + 92.25 \angle 40.48^\circ V_{rms}$$

$$\boxed{V_s = 315.90 \angle 10.93^\circ V_{rms}}$$

Problem 9.53

Find the input source voltage and the power factor of the source for the network shown in Fig P 9.53

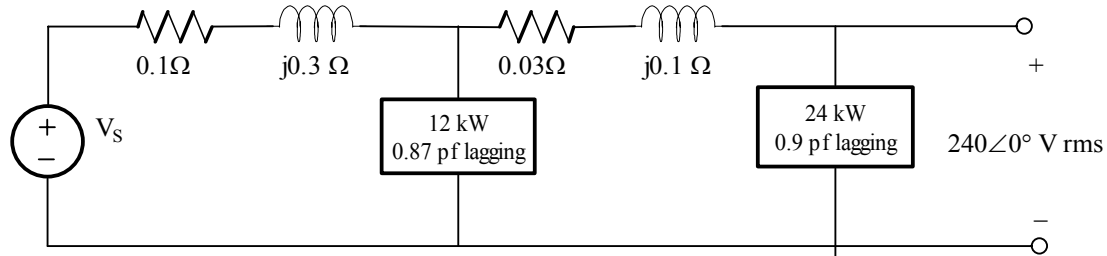
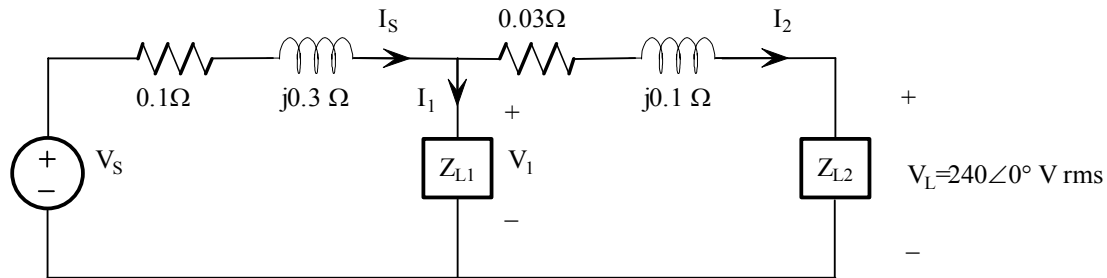

Figure P 9.53

Suggested Solution



Load 1: 12kW 0.87 pf lagging

Load 2: 24kW 0.90 pf lagging

$$V_s = V_L + I_2 [0.03 + j0.1] + I_s [0.1 + j0.3]$$

$$I_s = I_1 + I_2$$

$$I_2 = \frac{P_2}{V_L (pf_2)} \angle -\cos^{-1}(pf_2) = 111.11 \angle -25.84^\circ A_{rms}$$

$$V_1 = V_L + (0.03 + j0.1)I_2 = 240 + (0.104 \angle 73.30^\circ)(111.11 \angle -25.84^\circ)$$

$$= 240 + 11.60 \angle 47.46^\circ = 247.99 \angle 1.98^\circ V_{rms}$$

$$V_s = V_1 + (0.1 + j0.3)I_s \quad I_s = I_1 + I_2$$

$$|I_1| = \frac{P_1}{V_1 (pf_1)} = \frac{12000}{(247.99)(0.87)} = 55.62 A_{rms}$$

$$\theta_{V_1} - \theta_{I_1} = \cos^{-1}(0.87) = 29.54^\circ \Rightarrow \theta_{I_1} = -27.56^\circ$$

$$I_1 = 55.62 \angle -27.56^\circ A_{rms}$$

$$I_s = 166.71 \angle -26.41^\circ A_{rms}$$

$$V_s = 247.99 \angle 1.98^\circ + (0.1 + j0.3)166.71 \angle -26.41^\circ$$

$$V_S = 288.16 \angle 8.48^\circ V_{rms}$$

$$\theta_S = \theta_{V_S} - \theta_{i_S} = 8.48^\circ - (-26.41^\circ) = 34.89^\circ$$

$$pf_{source} = \cos(34.89^\circ) = 0.82 \text{lagging}$$

Problem 9.54

Use Kirchhoff's laws to compute the source voltage of the network shown in Fig P 9.54.

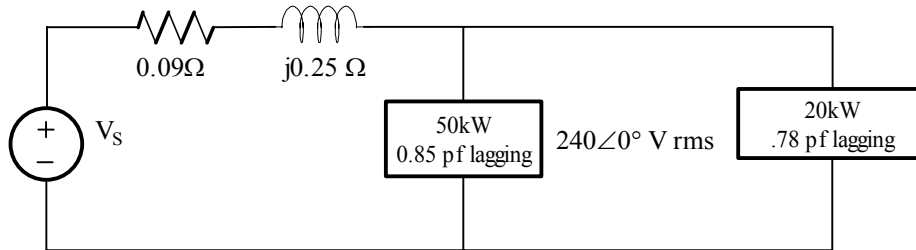
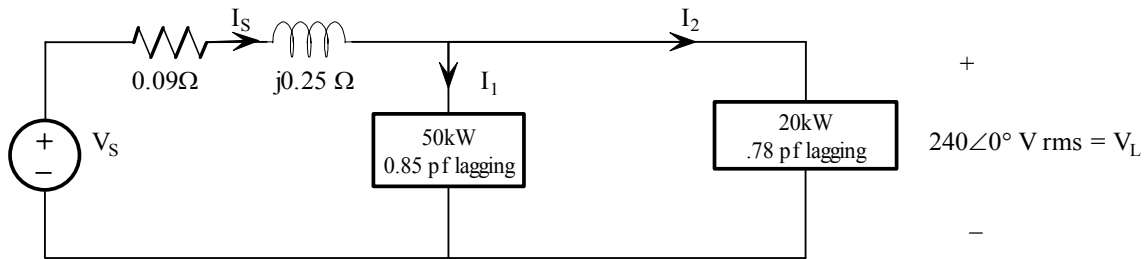

Figure P 9.54

Suggested Solution



Find I_1 :

$$|I_1| = \frac{P_1}{|V_L|(pf_1)} = \frac{50,000}{240(0.85)} = 245.10$$

$$\theta_{I_1} = -\cos^{-1}(0.85) = -31.79^\circ$$

$$I_1 = 245.10 \angle -31.79^\circ A_{rms}$$

Find I_2 :

$$|I_2| = \frac{P_2}{|V_L|(pf_2)} = \frac{20,000}{240(0.78)} = 106.84$$

$$\theta_{I_2} = -\cos^{-1}(0.78) = -38.74^\circ$$

$$I_2 = 106.84 \angle -38.74^\circ A_{rms}$$

Find I_s :

$$I_s = I_1 + I_2 = 351.40 \angle -33.90^\circ A_{rms}$$

Find V_s :

$$\begin{aligned} V_s &= I_s(0.09 + j0.25) + 240 \\ &= (351.40 \angle -33.90^\circ)(0.266 \angle 70.20^\circ) + 240 \\ &= 93.37 \angle 36.30^\circ + 240 \end{aligned}$$

$$\boxed{V_s = 320.06 \angle 9.95^\circ V_{rms}}$$

Problem 9.55

Given the network in Fig P9.55, determine the input voltage V_S .

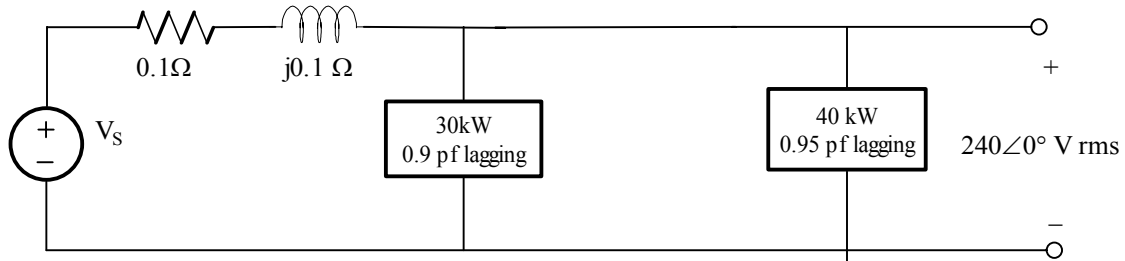
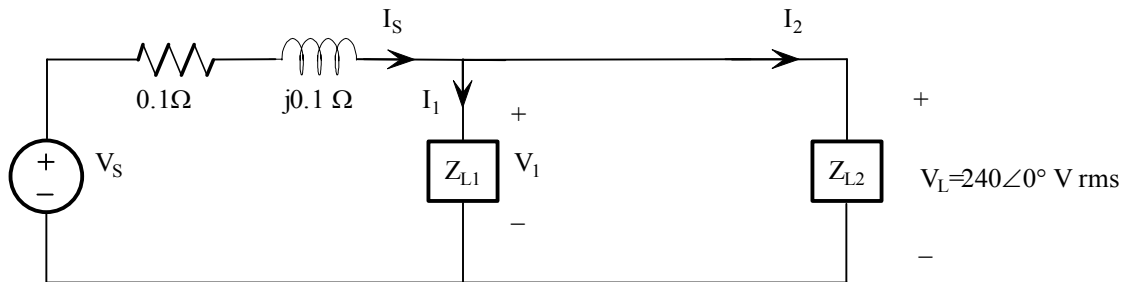

Figure P 9.55

Suggested Solution



Load 1: 30 kVA 0.9 pf lagging

Load 2: 40 kVA 0.95 pf lagging

$$V_S = V_L + I_S (0.1 + j0.1) \qquad I_S = I_1 + I_2$$

$$\text{Find } I_1: \quad |I_1| = \frac{P_1}{|V_L| (pf_1)} = \frac{|S_1|}{|V_L|} = \frac{30,000}{240} = 125 A_{rms}$$

$$\theta_{I_1} = -\cos^{-1}(0.9) = -25.84^\circ$$

$$I_1 = 125 \angle -25.84^\circ A_{rms}$$

$$\text{Find } I_2: \quad |I_2| = \frac{P_2}{|V_L| (pf_2)} \angle -\cos^{-1}(pf_2) = 175.44 \angle -18.19^\circ A_{rms}$$

$$\text{Find } I_S: \quad I_S = I_1 + I_2 = 299.79 \angle -21.38^\circ A_{rms}$$

$$\begin{aligned} V_S &= 240 + (0.1 + j0.1)I_S \\ &= 240 + [0.1\sqrt{2} \angle 45^\circ][299.79 \angle -21.38^\circ] \\ &= 279.24 \angle 3.48^\circ V_{rms} \end{aligned}$$

$$\boxed{V_S = 279.24 \angle 3.48^\circ V_{rms}}$$

Problem 9.56

What value of capacitance must be placed in parallel with the 18-kW load in Problem 9.51 in order to raise the power factor of this load to 0.9 lagging?

Suggested Solution

$$P_{old} = 18000W \quad \theta_{old} = \cos^{-1}.8 = 36.87^\circ$$

$$Q_{old} = P_{old} \tan \theta = 18000 \tan 36.87 = 13500VAR$$

$$S_{old} = 18000 + j13500VA$$

$$P_{Fnew} = .9 \quad \therefore \theta_{new} = 25.84^\circ$$

$$S_{new} = 18000 + j18000 \tan 25.84 = 18000 + j8718$$

$$S_{cap} = S_{new} - S_{old} = -j4782$$

$$C = \frac{4782}{(377)(220)^2} = \boxed{262\mu F}$$

Problem 9.57

An industrial load is supplied through a transmission line that has a line impedance of $0.1 + j0.2 \Omega$. The 60-Hz line voltage at the load is $480\angle 0^\circ$ V rms. The load consumes 124 kW at 0.75pf lagging. What value of capacitance when placed in parallel with the load will change the power factor to 0.9 lagging?

Suggested Solution

$$P_{old} = 124kW \quad \theta_{old} = \cos^{-1}.75 = 41.41^\circ$$

$$Q_{old} = P_{old} \tan \theta = 124000 \tan 41.41 = 109358VAR$$

$$S_{old} = 124000 + j109358VA$$

$$P_{Fnew} = .9 \quad \therefore \theta_{new} = 25.84^\circ$$

$$S_{new} = 124000 + j124000 \tan 25.84 = 124000 + j60056$$

$$S_{cap} = S_{new} - S_{old} = -j49302$$

$$C = \frac{49302}{(377)(480)^2} = \boxed{567.6\mu F}$$

Problem 9.58

A plant consumes 60 kW at a power factor of 0.5 lagging from a 220-V rms 60-Hz line. Determine the value of the capacitor which when placed in parallel with the load will change the load power factor to 0.9 lagging.

Suggested Solution

$$I_L = \frac{60,000}{(220)(0.5)} = 545.45 \angle \cos^{-1} 0.5 A$$

$$Q_{old} = 60,000 \tan(-60^\circ) = 103,923 VAR$$

$$S_{old} = 60,000 + j103,923 VA$$

$$P_{Fnew} = .9 \quad \therefore \theta_{new} = 25.84^\circ$$

$$S_{new} = 60,000 + j60,000 \tan 25.84 = 60000 + j29056$$

$$S_{cap} = S_{new} - S_{old} = 29056 - 103,923 = -74866$$

$$C = \frac{74866}{(377)(220)^2} = \boxed{4103 \mu F}$$

Problem 9.59

A small plant has a bank of induction motors that consume 64 kW at a pf of 0.68 lagging. The 60-Hz line voltage across the motors is $220\angle 0^\circ$ V rms. The local power company has tolod the plant to raise the pf to 0.92 lagging. What value of capacitance is required?

Suggested Solution

$$P_{old} = 64kW \angle 47.2^\circ$$

$$Q_{old} = P_{old} \tan 47.2^\circ = 69,000VAR$$

$$S_{old} = 64000 + 69,000j$$

$$Q_{new} = \tan^{-1} .42 = 23.1^\circ$$

$$S_{new} = 64000 + j64000 \tan 21.3^\circ = 64000 + 27,264j$$

$$\text{Then, } S_{cap} = S_{new} - S_{old} = -41.744j$$

$$C = \frac{S_{cap}}{\omega V_{rms}^2} = \frac{41.744}{(377)(220)^2} = \boxed{2,288\mu F}$$

Problem 9.60

The 60-Hz line voltage for a 60-kW, 0.76-pf lagging industrial load is $440\angle 0^\circ$ V rms. Find the value of the capacitance which when placed in parallel with the load will raise the power factor to 0.9 lagging.

Suggested Solution

$$P_{old} = 60,000\angle 40.5^\circ$$

$$Q_{old} = 60,000 \tan 40.5 = 51,300\text{VAR}$$

$$S_{old} = 60,000 + j51,300\text{VA}$$

With the capacitor in place, $\text{pf}=0.9$ $\theta=25.8^\circ$

$$S_{new} = 60,000 + j60,000 \tan 25.8^\circ$$

$$= 60,000 + j29,000\text{VA}$$

$$S_{cap} = S_{new} - S_{old} = -j22,300$$

$$C = \frac{22,300}{(377)(440)^2} = \boxed{305\mu\text{F}}$$

Problem 9.61

A particular load has a pf of 0.8 lagging. The power delivered to the load is 40 kW from a 220-V rms 60-Hz line. What value of capacitance placed in parallel with the load will raise the pf to 0.9 lagging?

Suggested Solution

$$I_L = \frac{40,000}{(220)(0.8)} = 227.3 \angle -36.9^\circ A$$

$$Q_{old} = 40,000 \tan(-36.9^\circ) = 30,000 VAR$$

$$S_{old} = 40,000 + j30,000$$

$$\text{With the capacitor, } P_{F_{new}} = .9, \theta_{new} = 25.8^\circ$$

$$S_{new} = 40,000 + j40,000 \tan 25.8^\circ = 40,000 + j20,000$$

$$So, S_{cap} = S_{new} - S_{old} = -10,000j$$

$$C = \frac{S_{cap}}{\omega(V_{rms})^2} = \frac{10,000}{(377)(220)^2} = \boxed{586 \mu F}$$

Problem 9.62

An industrial load consumes 44 kW at 0.82 pf lagging from a $220\angle 0^\circ$ V rms, 60-Hz line. A bank of capacitors totaling 900 μF is available. If these capacitors are placed in parallel with the load, what is the new power factor of the total load?

Suggested Solution

$$S_{cap} = -j(220)^2 (377)(900\mu\text{F}) = -j16,422$$

$$\text{Then, } S_{old} = 44,000 + j(44,000 \tan(\cos^{-1}.82))$$

$$44,000 + j30,712\text{VA}$$

$$S_{new} = S_{old} + S_{cap} = 44,000 + j14,300\text{VA}$$

$$\theta_{new} = \tan^{-1} \frac{14,300}{44,000} = 18^\circ$$

$$pf_{new} = .95\text{lag}$$

Problem 9.63

A bank of induction motors consumes 36 kW at 0.78 pf lagging from a 60-Hz, $220\angle 0^\circ$ V-rms line. If $500\mu\text{F}$ of capacitors is placed in parallel with the load, find the new power factor of the combined load.

Suggested Solution

$$I_L = \frac{36\text{kW}}{(220\angle 0^\circ)(.78)} = 209.8\angle -38.7^\circ$$

$$I_C = \frac{220\angle 0^\circ}{\frac{1}{j\omega C}} = 41.5j$$

$$\text{Then, } I_T = I_L + I_C = 209.8\angle -38.7^\circ + 41.5j = 186.7\angle -28.7^\circ$$

$$\text{Finally, } pf = \cos(28.7^\circ) = \boxed{.88(\text{lag})}$$

Problem 9.64

A single-phase three-wire 60-Hz circuit serves three loads, as shown in Fig P9.64. Determine I_{aA} , I_{nN} , I_C , and the energy use over a 24-hour period in kilowatt-hours.

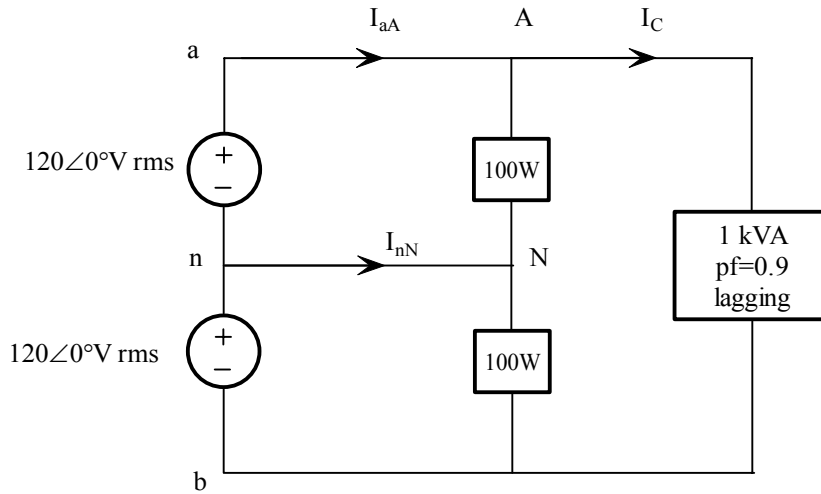

Figure P9.64

Suggested Solution

$$I_{AN} = \frac{P_{AN}}{V_{AN}} = \frac{100}{120\angle 0^\circ} = 0.833\angle 0^\circ \text{ Arms}$$

$$I_{NB} = \frac{P_{NB}}{V_{NB}} = \frac{100}{120\angle 0^\circ} = 0.833\angle 0^\circ \text{ Arms}$$

$$I_{nN} = I_{NB} - I_{AN} = 0 \text{ Arms}$$

$$I_C = \frac{S_C}{240} \angle -\cos^{-1}(0.9) = \frac{1000}{240} \angle -25.84^\circ = 4.17\angle -25.84^\circ \text{ Arms}$$

$$I_{aA} = I_C + I_{AN} = 4.17\angle -25.84^\circ + 0.833\angle 0^\circ$$

$$I_{aA} = 4.86\angle -21.60^\circ \text{ Arms}$$

$$I_{nN} = 0 \text{ Arms}$$

$$I_C = 4.17\angle -25.84^\circ \text{ Arms}$$

$$\text{Power usage} = 100 + 100 + 1000(0.9) = 1.1 \text{ kW}$$

$$E = \text{Energy} = \int p(t) dt = \overline{p(t)} \Delta t$$

$$\Delta t = 24 \text{ hours}$$

$$E = (1.1)(24) = 26.4 \text{ kW} \cdot \text{hr}$$

$$E = 26.4 \text{ kW} \cdot \text{hr}$$

Problem 9.65

A man and his son are flying a kite. The kite becomes entangled in a 7200-V power line close to a power pole. The man crawls up the pole to remove the kite. While trying to remove the kite, the man accidentally touches the 7200-V line. Assuming the power pole is well grounded, what is the potential current through the man's body?

Suggested Solution

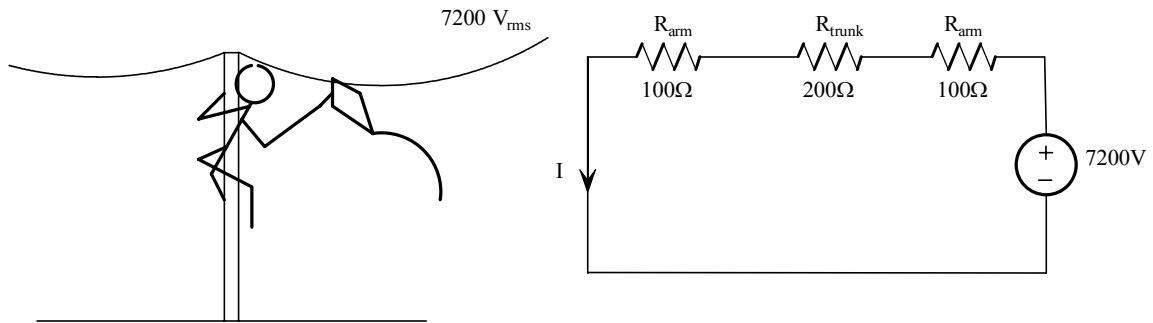

Assuming shoes provided a high resistance!

$$I = \frac{7200}{400} = 18A$$

Problem 9.66

A number of 120-V household fixtures are to be used to provide lighting for a large room. The total lighting load is 8 kW. The National Electric Code requires that no circuit breaker be large than 20 A with a 25% safety margin. Determine the number of identical branch circuits needed for this requirement.

Suggested Solution

$$P_L = 8kW \quad V_L = 120V_{rms} \quad I_L = \frac{P_L}{V_L} = 66.7A_{rms}$$

$$\# \text{ of branches} = \frac{I_L}{20} = 3.33$$

$$\# \text{ of breakers} = (1.25)(\# \text{ of branches}) = 4.17$$

$$\boxed{\# \text{ of breakers} = 5}$$

Problem 9.67

A 5.1-kW household range is designed to operate on a 240-V rms sinusoidal voltage, as shown in Fig. P9.67. However, the electrician has mistakenly connected the range to 120 V rms, as shown in Fig P9.67. What is the effect of this error?

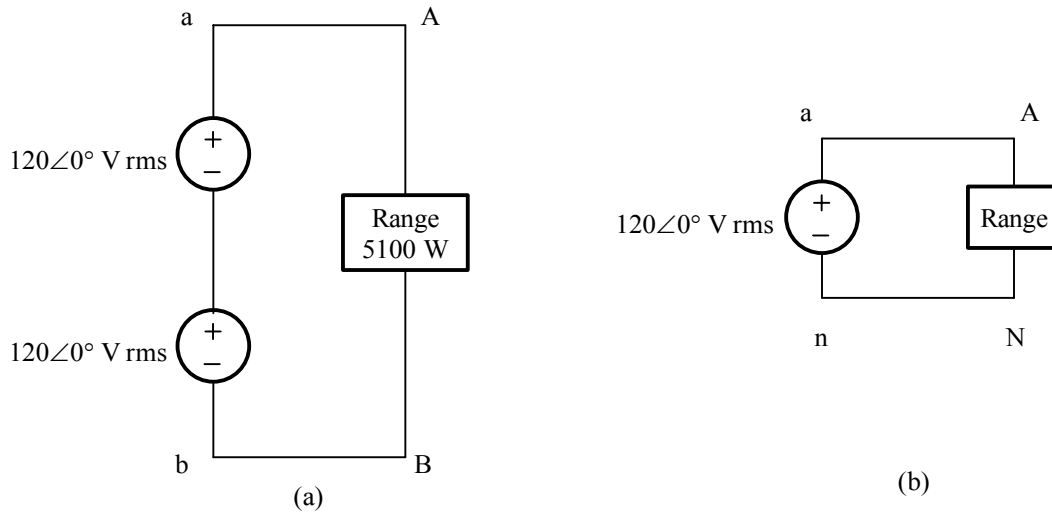

Figure P 9.67

Suggested Solution

$$R_{HE} = \frac{V^2}{P} = \frac{240^2}{5100} = 11.29\Omega$$

Now using 120V and the same R_{HE} .

$$P = \frac{120^2}{11.29} = 1275W$$

The heating element does not get as hot!

Problem 9.68

In order to test a light socket, a woman, while standing on cushions that insulate her from the ground, sticks her finger into the socket, as shown in Fig P9.68. The tip of her finger makes contact with one side of the line, and the side of her finger makes contact with the other side of the line. Assuming that any portion of a limb has a resistance of $95\ \Omega$, is there any current in the body? Is there any current in the vicinity of the heart?

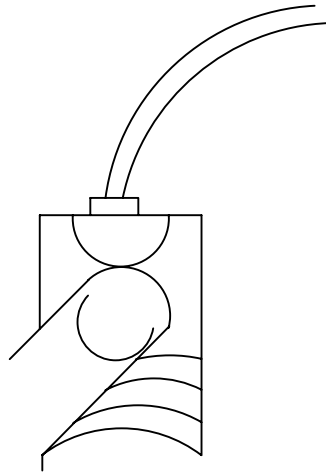
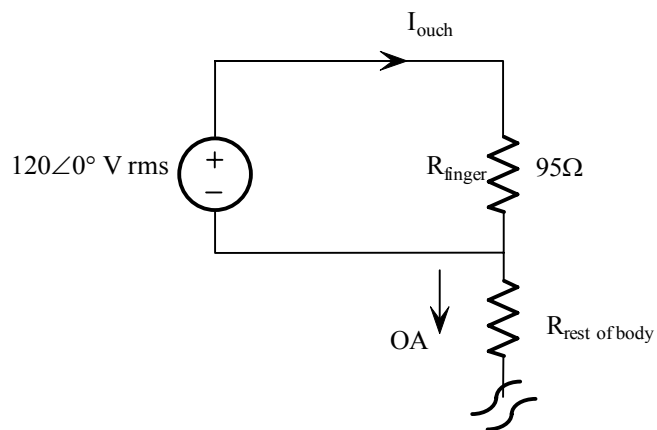

Figure P 9.68

Suggested Solution



$$I_{\text{ouch}} = 120 / 95 = 1.26\ \text{A}_{\text{rms}}$$

No current near the heart!

Problem 9.69

An inexperienced mechanic is installing a 12-V battery in a car. The negative terminal has been connected. He is currently tightening the bolts on the positive terminal. With a tight grip on the wrench, he turns it so that the gold ring on his finger makes contact with the frame of the car. This situation is modeled in Fig. P9.69, where we assume that the resistance of the wrench is negligible and the resistance of the contact is as follows:

$$R_1 = R_{\text{bolt to wrench}} = 0.012\Omega$$

$$R_2 = R_{\text{wrench to ring}} = 0.012\Omega$$

$$R_3 = R_{\text{ring}} = 0.012\Omega$$

$$R_4 = R_{\text{ring to frame}} = 0.012\Omega$$

What power is quickly dissipated in the gold ring, and what is the impact of this power dissipation?

Suggested Solution

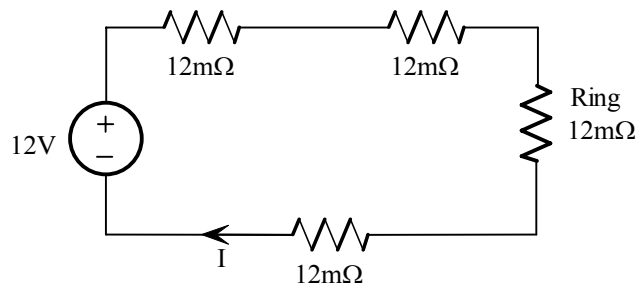

$$I = \frac{12}{48 \times 10^{-3}} = 250 A$$

$$P_{\text{ring}} = I^2 R_{\text{ring}} = \boxed{750W}$$

Ring will get very hot!

Finger will be burned!

Ring may spot weld to frame!

Problem 9FE-1

An industrial load consumes 120 kW at 0.707 pf lagging and is connected to a $480\angle 0^\circ$ V rms line. Determine the value of the capacitor which, when connected in parallel with the load, will raise the power factor to 0.95 lagging.

Suggested Solution

$$\theta_{old} = \cos^{-1} .707 = 45^\circ$$

$$Q_{old} = P_{old} \tan \theta_{old} = 120,000(1) = 120,000$$

$$\text{So, } S_{old} = 120,000 + j120,000 \text{ VA}$$

$$\theta_{new} = \cos^{-1} (0.95) = 18.19^\circ$$

$$Q_{new} = P_{new} \tan \theta_{new} = 120,000 \tan 18.19^\circ$$

$$= 39,431 \text{ VAR}$$

$$Q_{cap} = Q_{new} - Q_{old} = -\omega C V_{rms}^2$$

$$= 39,431 - 120,000 = -\omega C V^2$$

$$\frac{80569}{(377)(480)^2} = \boxed{C = 927.6 \mu\text{F}}$$

Problem 9FE-2

Determine the average and rms values of the following waveform.

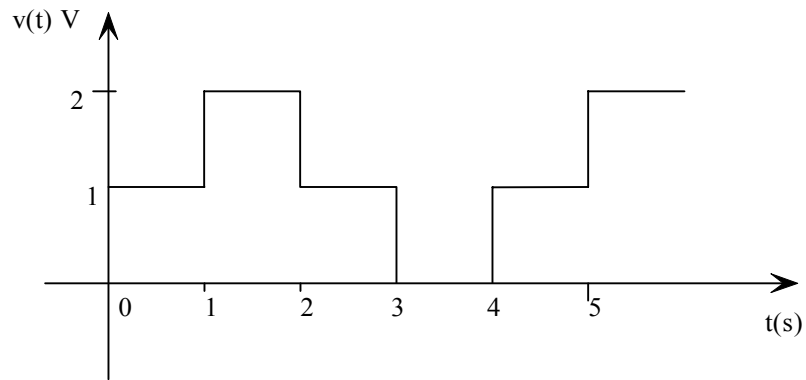

Figure 9FE-2

Suggested Solution

$$V_{ave} = \frac{1+2+1}{4} = 1V$$

$$V_{rms} = \left[\frac{1}{4} \left(\int_0^1 1 dt + \int_1^2 4 dt + \int_2^3 1 dt \right) \right]^{\frac{1}{2}}$$

$$= \left[\frac{1}{4} (1+4+1) \right]^{\frac{1}{2}} = \boxed{1.22V_{rms}}$$

Problem 9FE-3

Find the impedance Z_L in the network in Fig 9PFE-3 for maximum average power transfer.

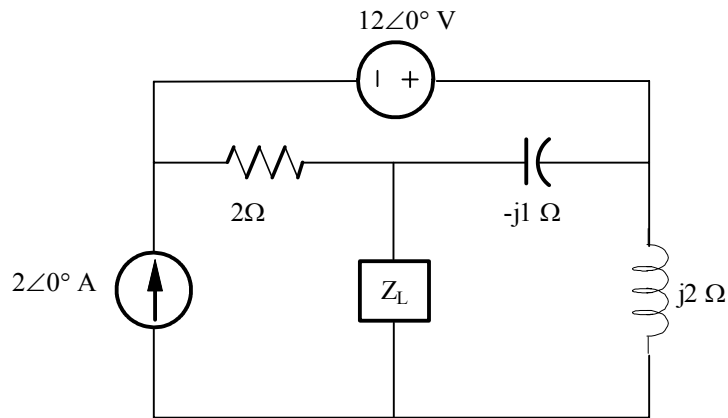
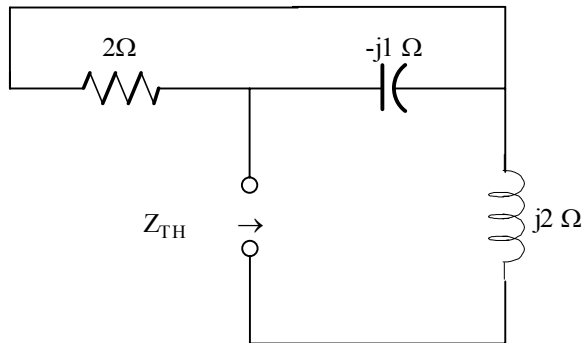

Figure 9PFE-3

Suggested Solution



$$\begin{aligned}
 Z_{TH} &= \frac{(2)(-j1)}{2-j1} + j2 \\
 &= \frac{-j2(2+j1)}{5} + j2 \\
 &= \frac{-j4+2}{5} + j2 \\
 &= 0.4 + j1.2\Omega \\
 \therefore Z_L &= 0.4 - j1.2\Omega
 \end{aligned}$$

Problem 9FE-4

A rms-reading voltmeter is connected to the output of the op-amp shown in Fig. 9PFE-4. Determine the meter reading.

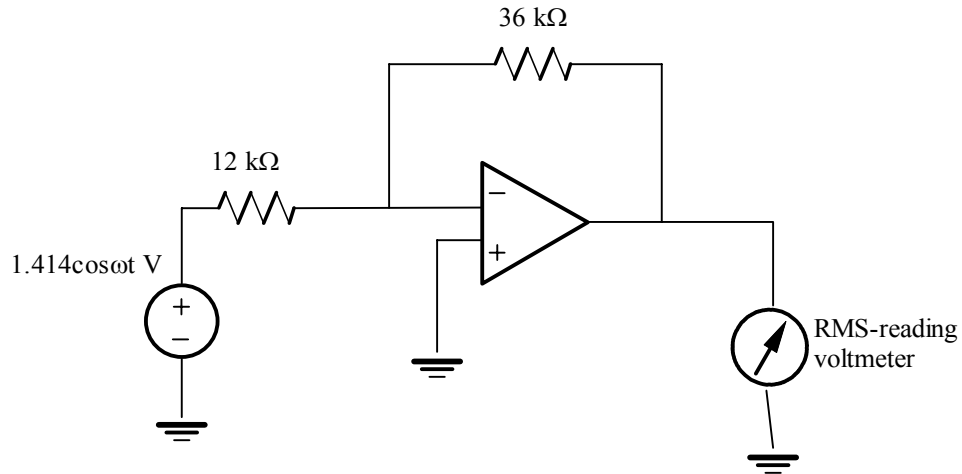

Figure 9PFE-4

Suggested Solution

$$\text{Gain} = \frac{-36k}{12k} = -3$$

$$\therefore \text{Voltmeter reading} = \left| \frac{1.414}{\sqrt{2}} (-3) \right| = 3 \text{ volts rms}$$

Problem 9FE-5

Determine the average power delivered to the resistor in Fig. 9PFE-5a if the current waveform is shown in Fig. 9PFE-5b.

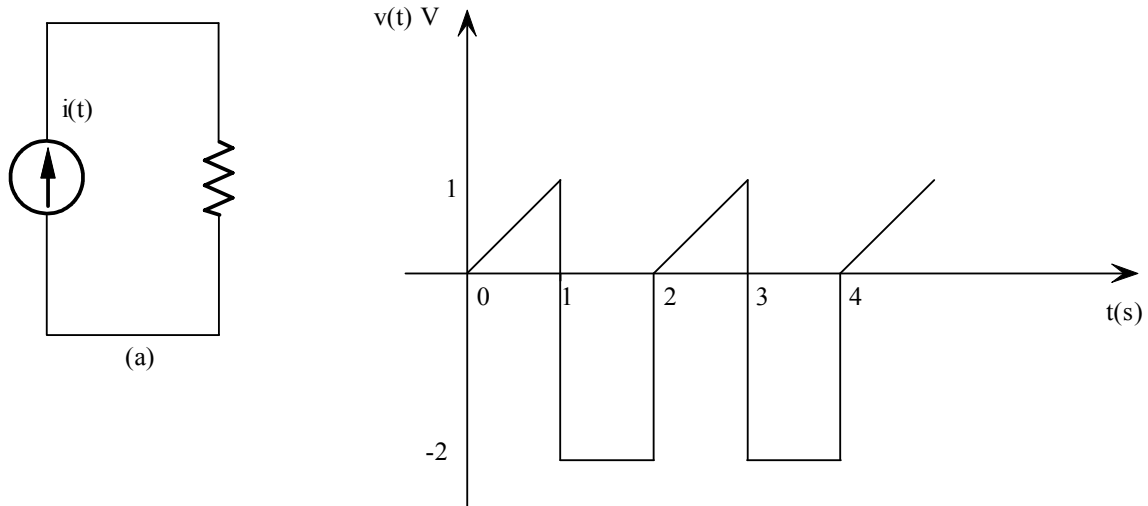

Figure 9PFE-5

Suggested Solution

$$I_{rms} = \left\{ \frac{1}{2} \left(\int_0^1 (t)^2 dt + \int_1^2 (-2)^2 dt \right) \right\}^{\frac{1}{2}}$$

$$= \left\{ \frac{1}{2} \left(\frac{t^3}{3} \Big|_0^1 + 4t \Big|_1^2 \right) \right\}^{\frac{1}{2}}$$

$$= 1.47 A$$

Then

$$P_{ave} = I_{rms}^2 (4) = 8.67 W$$

Problem 10.1

Sketch a phasor representation of a balanced three-phase system containing both phase voltages and line voltages if $V_{an} = 100\angle 45^\circ$ V rms. Label all magnitudes and assume an *abc*-phase sequence.

Suggested Solution

Phase voltages:

$$V_{an} = 100\angle 45^\circ \text{ V rms}$$

$$V_{bn} = 100\angle -75^\circ \text{ V rms}$$

$$V_{cn} = 100\angle -195^\circ \text{ V rms}$$

Line voltages:

$$\begin{aligned} \text{Magnitude} &= \sqrt{3} \times \text{phase voltage magnitude} \\ \text{Angle} &= \text{phase voltage angle} + 30^\circ \end{aligned}$$

$$V_{ab} = 173.2\angle 75^\circ \text{ V rms}$$

$$V_{bc} = 173.2\angle -45^\circ \text{ V rms}$$

$$V_{ca} = 173.2\angle -165^\circ \text{ V rms}$$

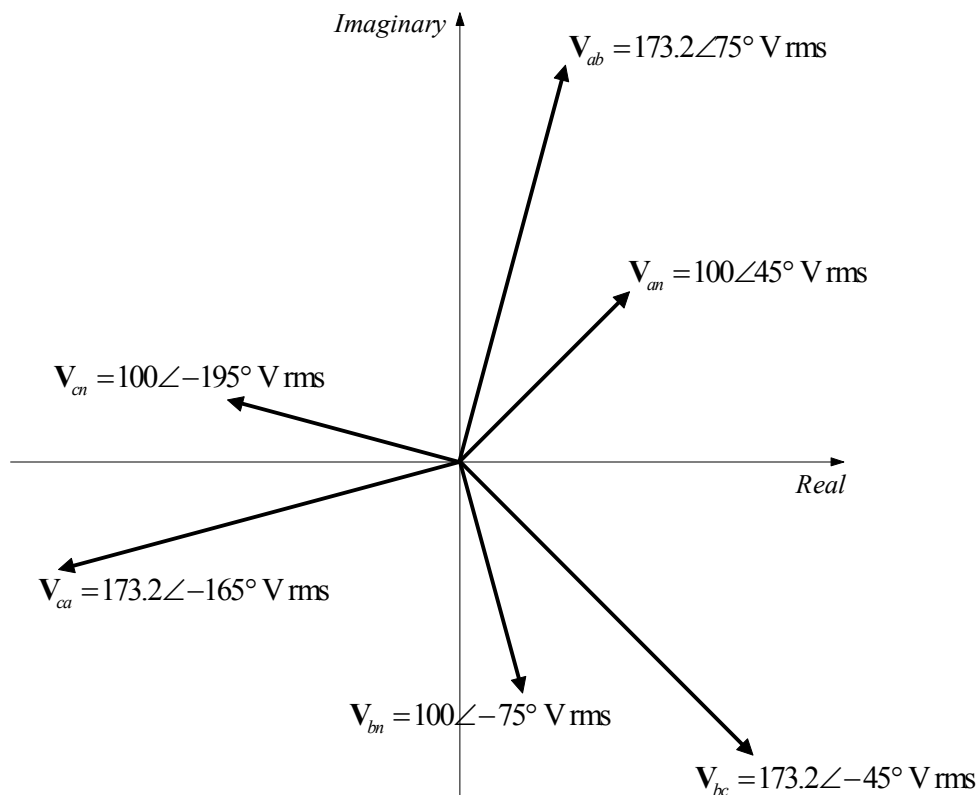

Problem 10.2

A positive-sequence three-phase balanced wye voltage source has a phase voltage of $\mathbf{V}_{an} = 100\angle 20^\circ \text{ V}$. Determine the line voltages of the source.

Suggested Solution

\mathbf{V}_{ab} leads \mathbf{V}_{an} by 30° . Therefore,

$$\mathbf{V}_{ab} = 100\sqrt{3}\angle 50^\circ = 173.2\angle 50^\circ \text{ V rms ,}$$

$$\mathbf{V}_{bc} = 173.2\angle -70^\circ \text{ V rms , and}$$

$$\mathbf{V}_{ca} = 173.2\angle -190^\circ \text{ V rms .}$$

Problem 10.3

Sketch a phasor representation of an *abc*-sequence balanced three-phase Δ -connected source, including V_{ab} , V_{bc} , and V_{ca} if $V_{ab} = 208\angle 0^\circ$ V rms.

Suggested Solution

$$V_{ab} = 208\angle 0^\circ \text{ V rms}$$

$$V_{bc} = 208\angle -120^\circ \text{ V rms}$$

$$V_{ca} = 208\angle 120^\circ \text{ V rms}$$

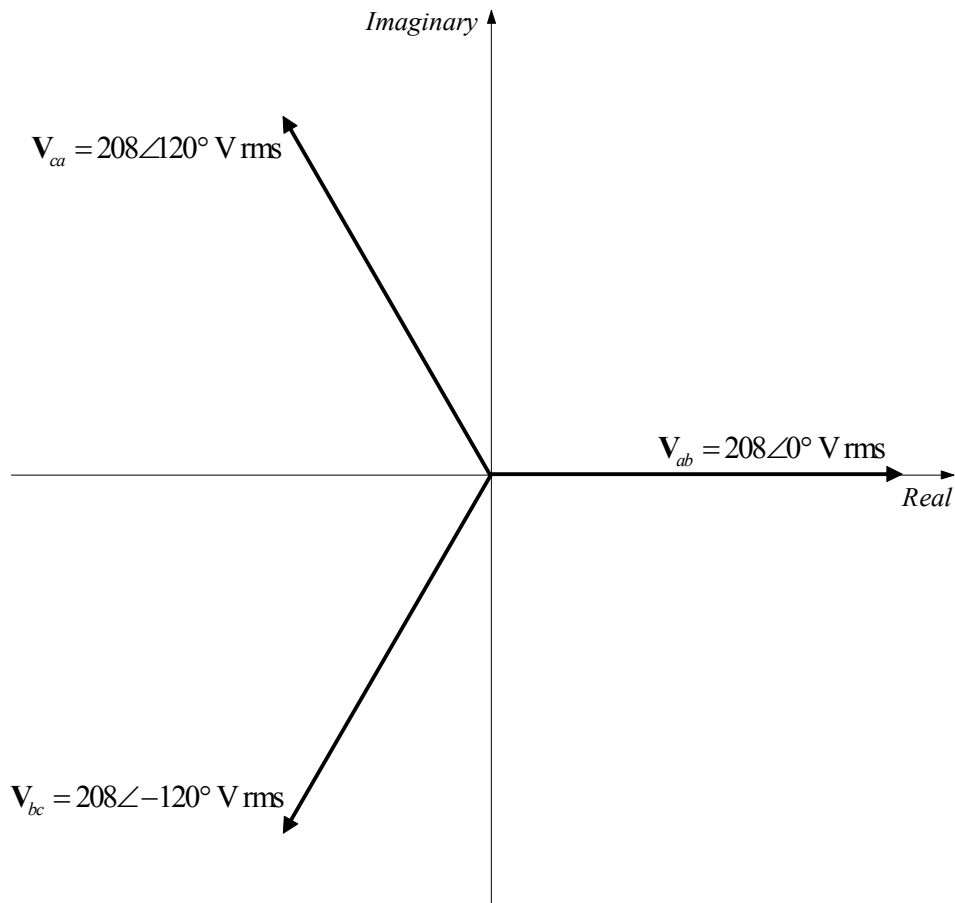

Problem 10.4

Sketch a phasor representation of a balanced three-phase system containing both phase voltages and line voltages if $V_{an} = 120\angle 60^\circ$ V rms. Label all magnitudes and assume an *abc*-phase sequence.

Suggested Solution

$$V_{an} = 120\angle 60^\circ \text{ V rms}$$

$$V_{ab} = 208\angle 90^\circ \text{ V rms}$$

$$V_{bn} = 120\angle -60^\circ \text{ V rms}$$

$$V_{bc} = 208\angle -30^\circ \text{ V rms}$$

$$V_{cn} = 120\angle 180^\circ \text{ V rms}$$

$$V_{ca} = 208\angle -150^\circ \text{ V rms}$$

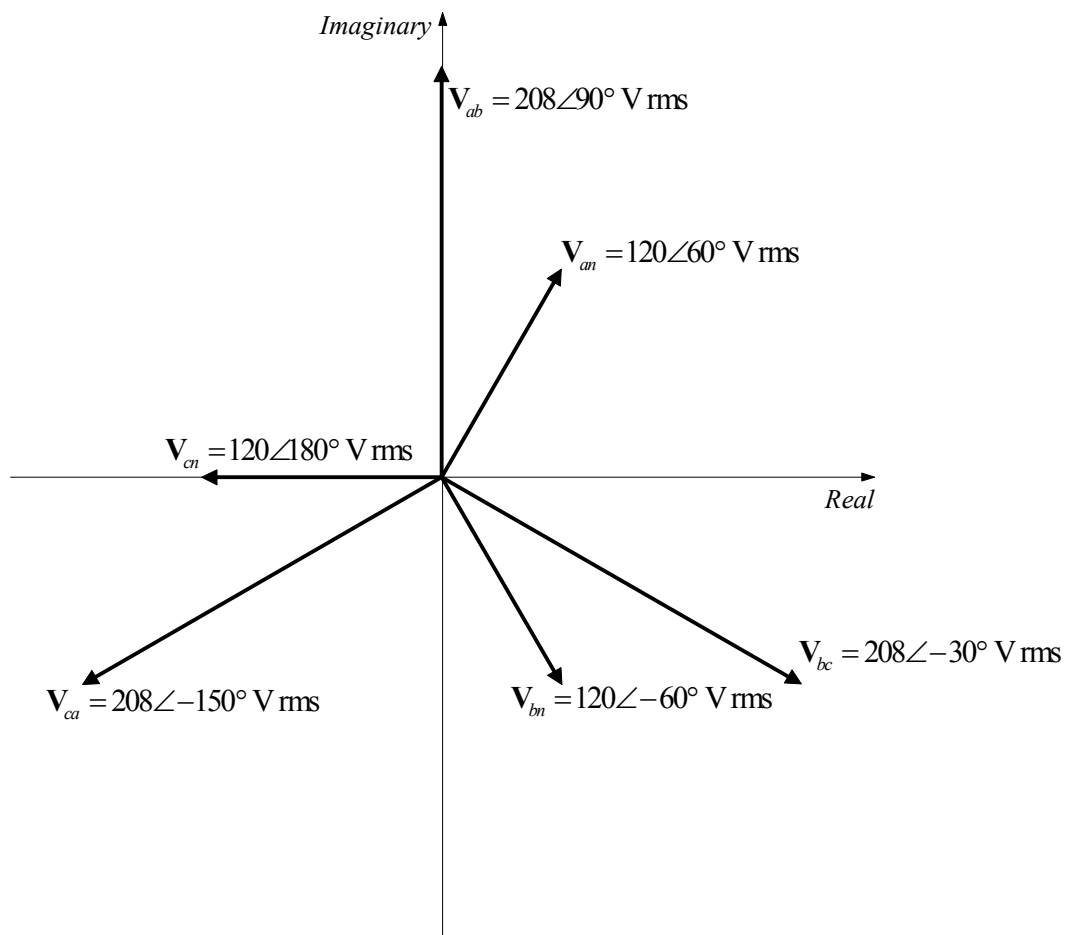

Problem 10.5

A positive-sequence three-phase balanced wye voltage source has a phase voltage of $\mathbf{V}_{an} = 240\angle 90^\circ$ V rms. Determine the line voltages of the source.

Suggested Solution

$$\mathbf{V}_{ab} = \sqrt{3} \cdot |\mathbf{V}_{an}| \angle (\theta_{\mathbf{V}_{an}} + 30^\circ) = 415.7\angle 120^\circ \text{ V rms}$$

$$\mathbf{V}_{bc} = 415.7\angle 0^\circ \text{ V rms}$$

$$\mathbf{V}_{ca} = 415.7\angle -120^\circ \text{ V rms}$$

Problem 10.6

Sketch a phasor representation of a balanced three-phase system containing both phase voltages and line voltages if $V_{ab} = 208\angle 45^\circ$ V rms. Label all phasors and assume an abc -phase sequence.

Suggested Solution

$$V_{ab} = 208\angle 45^\circ \text{ V rms}$$

$$V_{an} = \frac{|V_{ab}|}{\sqrt{3}} \angle (\theta_{V_{ab}} - 30^\circ) = 120\angle 15^\circ \text{ V rms}$$

$$V_{bc} = 208\angle -75^\circ \text{ V rms}$$

$$V_{bn} = 120\angle -105^\circ \text{ V rms}$$

$$V_{ca} = 208\angle 165^\circ \text{ V rms}$$

$$V_{cn} = 120\angle 135^\circ \text{ V rms}$$

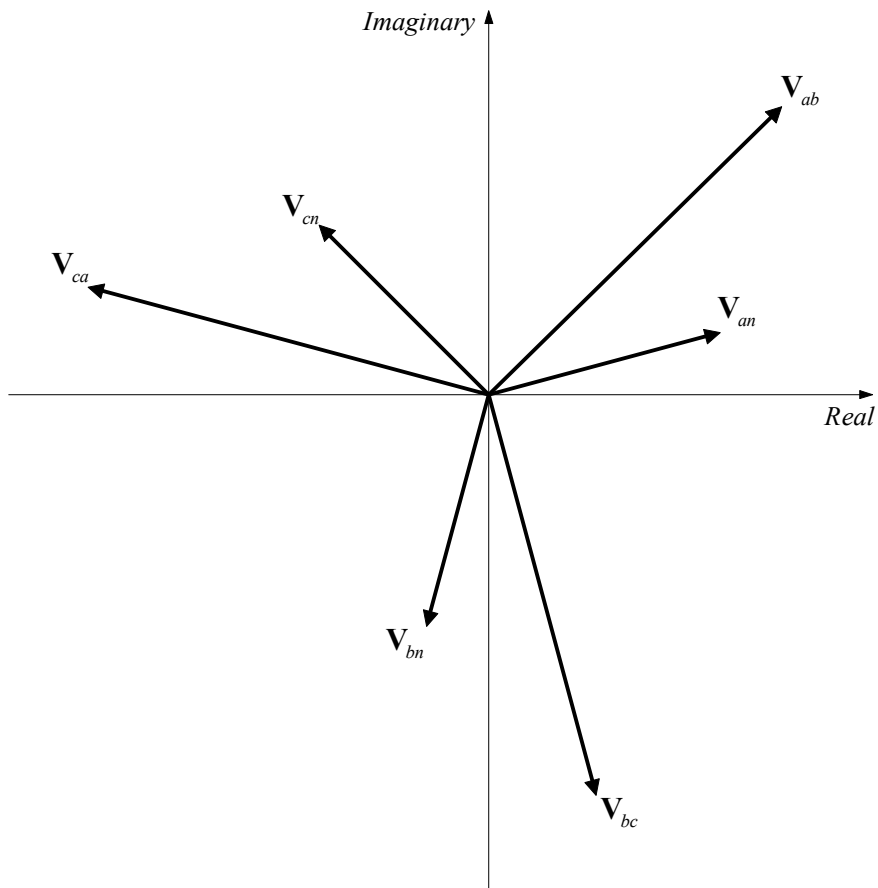

Problem 10.7

A positive-sequence balanced three-phase wye-connected source with a phase voltage of 100 V supplies power to a balanced wye-connected load. The per phase load impedance is $40 + j10\Omega$. Determine the line currents in the circuit if $\angle \mathbf{V}_{an} = 0^\circ$.

Suggested Solution

$$\mathbf{I}_{an} = \frac{\mathbf{V}_{an}}{\mathbf{Z}_\phi} = \frac{100 + j0}{40 + j10} = 2.43 \angle -14^\circ \text{ A rms}$$

$$\mathbf{I}_{bn} = 2.43 \angle -134^\circ \text{ A rms}$$

$$\mathbf{I}_{cn} = 2.43 \angle -254^\circ \text{ A rms}$$

Problem 10.8

A positive-sequence balanced three-phase wye-connected source supplies power to a balanced wye-connected load. The magnitude of the line voltages is 150 V. If the load impedance per phase is $36 + j12 \Omega$, determine the line currents if $\angle V_{an} = 0^\circ$.

Suggested Solution

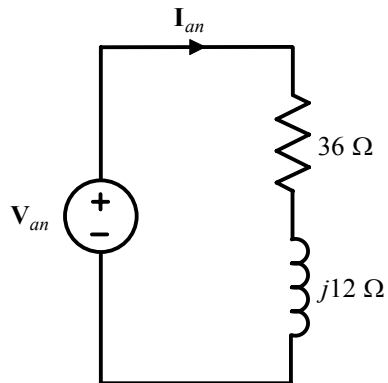

$$V_{an} = \frac{150}{\sqrt{3}} \angle 0^\circ = 86.6 \angle 0^\circ \text{ V rms} \quad \Rightarrow \quad I_{an} = \frac{86.6 + j0}{36 + j12} = 2.28 \angle -18.43^\circ \text{ A rms}$$

$$I_{bn} = 2.28 \angle -138.43^\circ \text{ A rms}$$

$$I_{cn} = 2.28 \angle -258.43^\circ \text{ A rms}$$

Problem 10.9

An *abc*-sequence balanced three-phase wye-connected source supplies power to a balanced wye-connected load. The line impedance per phase is $1 + j0 \Omega$, and the load impedance per phase is $20 + j20 \Omega$. If the source line voltage V_{ab} is $100\angle 0^\circ$ V rms, find the line currents.

Suggested Solution

$$V_{an} = \frac{100}{\sqrt{3}} \angle (0^\circ - 30^\circ) = 57.74 \angle -30^\circ \text{ V rms}$$

$$I_{aA} = \frac{57.74 \angle -30^\circ}{(20 + j20) + (1 + j0)} = \frac{57.74 \angle -30^\circ}{21 + j20} = 1.99 \angle -73.6^\circ \text{ A rms}$$

$$I_{bB} = 1.99 \angle -193.6^\circ \text{ A rms}$$

$$I_{cC} = 1.99 \angle -313.6^\circ \text{ A rms}$$

Problem 10.10

In a three-phase balanced wye-wye system, the source is an *abc*-sequence set of voltages with $\mathbf{V}_{an} = 120\angle 60^\circ$ V rms. The per phase impedance of the load is $12 + j16\Omega$. If the line impedance per phase is $0.8 + j1.4\Omega$, find the line currents and the load voltages.

Suggested Solution

Line currents:

$$\mathbf{I}_{AN} = \frac{\mathbf{V}_{an}}{\mathbf{Z}_\phi + \mathbf{Z}_L} = \frac{120\angle 60^\circ}{(12 + j16) + (0.8 + j1.4)} = \frac{120\angle 60^\circ}{21.6\angle 53.7^\circ} = 5.56\angle 6.3^\circ \text{ A rms}$$

$$\mathbf{I}_{BN} = 5.56\angle -113.7^\circ \text{ A rms}$$

$$\mathbf{I}_{CN} = 5.56\angle 126.3^\circ \text{ A rms}$$

Load voltages:

$$\mathbf{V}_{AN} = \frac{\mathbf{Z}_\phi}{\mathbf{Z}_\phi + \mathbf{Z}_L} \cdot \mathbf{V}_{an} = \frac{12 + j16}{12.8 + j17.4} \cdot (120\angle 60^\circ) = 111.1\angle 59.4^\circ \text{ V rms}$$

$$\mathbf{V}_{BN} = 111.1\angle -60.6^\circ \text{ V rms}$$

$$\mathbf{V}_{CN} = 111.1\angle 179.4^\circ \text{ V rms}$$

Problem 10.11

An *abc*-sequence set of voltages feeds a balanced three-phase wye-wye system. The line and load impedances are $0.6 + j1 \Omega$ and $18 + j14 \Omega$, respectively. If the load voltage on the *a* phase is $\mathbf{V}_{AN} = 114.47 \angle 18.99^\circ$ V rms, determine the voltages at the line input.

Suggested Solution

$$\mathbf{I}_a = \frac{\mathbf{V}_{AN}}{18 + j14} = 5.02 \angle -18.88^\circ \text{ A rms}$$

$$\mathbf{V}_{an} = \mathbf{I}_a (\mathbf{Z}_{line} + \mathbf{Z}_{load}) = \mathbf{I}_a \mathbf{Z}_{line} + \mathbf{V}_{AN} = (5.02 \angle -18.88^\circ)(0.6 + j1) + 114.47 \angle 18.99^\circ = 120 \angle 20^\circ \text{ V rms}$$

$$\mathbf{V}_{bn} = 120 \angle -100^\circ \text{ V rms}$$

$$\mathbf{V}_{cn} = 120 \angle -220^\circ \text{ V rms}$$

Problem 10.12

In a balanced three-phase wye-wye system, the source is an *abc*-sequence set of voltages. The load voltage on the *a* phase is $\mathbf{V}_{AN} = 108.58\angle 79.81^\circ$ V rms, $\mathbf{Z}_{line} = 1 + j1.4\Omega$, and $\mathbf{Z}_{load} = 10 + j13\Omega$. Determine the input sequence of voltages.

Suggested Solution

$$\mathbf{I}_a = \frac{\mathbf{V}_{AN}}{\mathbf{Z}_{load}} = 6.62\angle 27.38^\circ \text{ A rms}$$

$$\mathbf{V}_{an} = \mathbf{I}_a \mathbf{Z}_{line} + \mathbf{V}_{AN} = \mathbf{I}_a (\mathbf{Z}_{line} + \mathbf{Z}_{load}) = 120\angle 80^\circ \text{ V rms}$$

$$\mathbf{V}_{bn} = 120\angle -40^\circ \text{ V rms}$$

$$\mathbf{V}_{cn} = 120\angle -160^\circ \text{ V rms}$$

Problem 10.13

A balanced abc -sequence of voltages feeds a balanced three-phase wye-wye system. The line and load impedances are $0.6 + j0.9\Omega$ and $8 + j12\Omega$, respectively. The load voltage on the a phase is $V_{AN} = 116.63\angle 10^\circ$ V rms. Find the line voltage V_{ab} .

Suggested Solution

$$V_{an} = V_{AN} \cdot \frac{\mathbf{Z}_{line} + \mathbf{Z}_{load}}{\mathbf{Z}_{load}} = (116.63\angle 10^\circ) \frac{8.6 + j12.9}{8 + j12} = 125.5\angle 10^\circ \text{ V rms}$$

$$V_{ab} = \sqrt{3} \cdot V_{an} \angle (\theta_{V_{an}} + 30^\circ) = 217.4\angle 40^\circ \text{ V rms}$$

Problem 10.14

In a balanced three-phase wye-wye system, the source is an *abc*-sequence set of voltages. $\mathbf{Z}_{line} = 1 + j1.8 \Omega$, $\mathbf{Z}_{load} = 14 + j12 \Omega$, and the load voltage on the *a* phase is $\mathbf{V}_{AN} = 398.1 \angle 17.99^\circ$ V rms. Find the line voltage \mathbf{V}_{ab} .

Suggested Solution

$$\mathbf{I}_a = \frac{\mathbf{V}_{AN}}{\mathbf{Z}_{load}} = \frac{398.1 \angle 17.99^\circ}{14 + j12} = 21.59 \angle -22.61^\circ \text{ A rms}$$

$$\mathbf{V}_{an} = \mathbf{I}_a (\mathbf{Z}_{line} + \mathbf{Z}_{load}) = (21.59 \angle -22.61^\circ)(15 + j13.8) = 440 \angle 20^\circ \text{ V rms}$$

$$\Rightarrow \mathbf{V}_{ab} = 440\sqrt{3} \angle 50^\circ = 762.1 \angle 50^\circ \text{ V rms}$$

Problem 10.15

An abc -phase sequence balanced three-phase source feeds a balanced load. The system is connected wye-wye and $\angle \mathbf{V}_{an} = 0^\circ$. The line impedance is $0.5 + j0.2 \Omega$, the load impedance is $16 + j10 \Omega$, and the total power absorbed by the load is 1836.54 W. Determine the magnitude of the source voltage V_{an} .

Suggested Solution

$$P_{\phi, load} = \frac{1836.54}{3} = 612.18 \text{ W} \quad \mathbf{Z}_L = R_L + jX_L = 16 + j10 \Omega$$

$$I_{aA}^2 = \frac{612.18}{R_L} = \frac{612.18}{16} = 38.26 \text{ W}/\Omega \quad \Rightarrow \quad I_{aA} = 6.19 \text{ A rms}$$

The total impedance is $16.5 + j10.2 = 19.4 \angle 31.72^\circ \Omega$

Therefore, since $\angle \mathbf{V}_{an} = 0^\circ$, $\mathbf{I}_{aA} = 6.19 \angle -31.72^\circ \text{ A rms}$

and

$$V_{an} = 6.19 \times 19.4 = 120 \text{ V rms}$$

Problem 10.16

In a balanced three-phase wye-wye system, the total power loss in the lines is 272.57 W. $V_{an} = 105.28\angle 31.65^\circ$ V rms and the power factor of the load is 0.77 lagging. If the line impedance is $2 + j1\ \Omega$, determine the load impedance.

Suggested Solution

If the total line loss is 272.57 W, then the loss per phase is $\frac{272.57}{3} = 90.86$ W

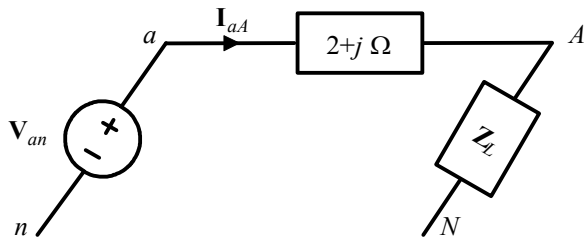

$$P_{\phi, loss} = I_{aA}^2 \times \text{Re}\{Z_{line}\} = 2 \cdot I_{aA}^2 = 90.86 \text{ W} \quad \Rightarrow \quad I_{aA} = 6.74 \text{ A rms}$$

Then,

$$Z_L = \frac{105.28}{6.74} = 15.62 \ \Omega$$

$$\theta_{Z_L} = \cos^{-1}(0.77) = 39.8^\circ \quad (\text{lagging pf})$$

So,

$$Z_L = 15.62\angle 39.8^\circ = 12 + j10 \ \Omega$$

Problem 10.17

In a balanced three-phase wye-wye system the load impedance is $8 + j4\Omega$. The source has phase sequence abc and $V_{an} = 120\angle 0^\circ$ V rms. If the load voltage is $V_{AN} = 111.62\angle -1.33^\circ$ V rms, determine the line impedance.

Suggested Solution

$$I_{aA} = \frac{111.62\angle -1.33^\circ}{8 + j4} = 12.48\angle -27.9^\circ \text{ A rms}$$

$$V_{line} = 120\angle 0^\circ - 111.62\angle -1.33^\circ = 8.8\angle 17.12^\circ \text{ V rms}$$

$$Z_{line} = \frac{8.8\angle 17.12^\circ}{12.48\angle -27.9^\circ} = 0.71\angle 45.02^\circ = 0.5 + j0.5 \Omega$$

Problem 10.18

In a balanced three-phase wye-wye system the load impedance is $10 + j1 \Omega$. The source has phase sequence abc and the line voltage $\mathbf{V}_{ab} = 220\angle 30^\circ$ V rms. If the load voltage $\mathbf{V}_{AN} = 120\angle 0^\circ$ V rms, determine the line impedance.

Suggested Solution

$$\mathbf{Z}_Y = 10 + j1 \Omega$$

$$\mathbf{V}_{an} = \frac{|\mathbf{V}_{ab}|}{\sqrt{3}} \angle (\theta_{V_{ab}} - 30^\circ) = \frac{220}{\sqrt{3}} \angle (30^\circ - 30^\circ) = 127.02\angle 0^\circ \text{ V rms}$$

Per phase Y circuit:

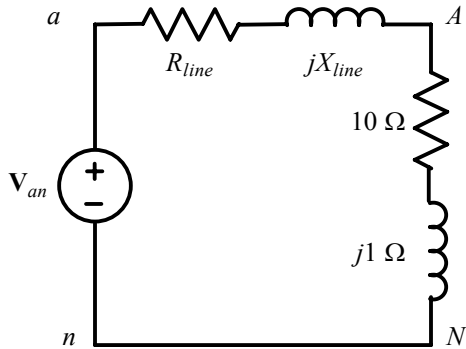

$$\mathbf{V}_{AN} = \left[\frac{\mathbf{Z}_Y}{\mathbf{Z}_Y + \mathbf{Z}_{line}} \right] \mathbf{V}_{an} \Rightarrow \mathbf{Z}_{line} = \mathbf{Z}_Y \left[\frac{\mathbf{V}_{an}}{\mathbf{V}_{AN}} - 1 \right] = (10 + j1) \left[\frac{127.02\angle 0^\circ}{120\angle 0^\circ} - 1 \right] = 0.59\angle 5.71^\circ \Omega$$

Problem 10.19

In a balanced three-phase wye-wye system, the load impedance is $20 + j12 \Omega$. The source has an abc -phase sequence and $V_{an} = 120\angle 0^\circ$ V rms. If the load voltage is $V_{AN} = 111.49\angle -0.2^\circ$ V rms, determine the magnitude of the line current if the load is suddenly short circuited.

Suggested Solution

$$I_{aA} = \frac{111.49\angle -0.2^\circ}{20 + j12} = 4.78\angle -31.16^\circ \text{ A rms}$$

$$V_{line} = 120\angle 0^\circ - 111.49\angle -0.2^\circ = 8.52\angle 2.62^\circ \text{ V rms}$$

$$Z_{line} = \frac{V_{line}}{I_{aA}} = \frac{8.52\angle 2.62^\circ}{4.78\angle -31.16^\circ} = 1.78\angle 33.78^\circ \Omega$$

$$\therefore |I_{a4sc}| = \frac{120}{1.78} = 67.42 \text{ A rms}$$

Problem 10.20

In a balanced three-phase wye-wye system, the source is an *abc*-sequence set of voltages and $V_{an} = 120\angle 50^\circ$ V rms. The load voltage on the *a* phase is $110.65\angle 29.03^\circ$ V rms and the load impedance is $16 + j20 \Omega$. Find the line impedance.

Suggested Solution

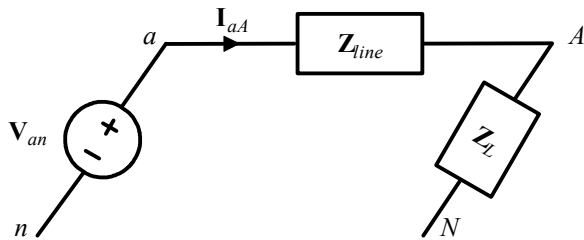

$$V_{an} = 120\angle 50^\circ \text{ V rms}$$

$$V_{AN} = 110.65\angle 29.03^\circ \text{ V rms}$$

$$Z_L = 16 + j20 = 25.6\angle 51.34^\circ \Omega$$

$$I_{aA} = \frac{V_{AN}}{Z_L} = \frac{110.65\angle 29.03^\circ}{25.6\angle 51.34^\circ} = 4.32\angle -22.31^\circ \text{ A rms}$$

Then,

$$Z_{line} = \frac{V_{line}}{I_{aA}} = \frac{120\angle 50^\circ - 110.65\angle 29.03^\circ}{4.32\angle -22.31^\circ} = 9.94\angle 139.4^\circ \Omega$$

Problem 10.21

In a balanced three-phase wye-wye system, the source is an *abc*-sequence set of voltages and $\mathbf{V}_{an} = 120\angle 40^\circ$ V rms. If the *a*-phase line current and line impedance are known to be $7.10\angle -10.28^\circ$ A rms and $0.8 + j1 \Omega$, respectively, find the load impedance.

Suggested Solution

$$\mathbf{Z}_T = \frac{120\angle 40^\circ}{7.10\angle -10.28^\circ} = 16.9\angle 50.28^\circ = 10.8 + j13 \Omega$$

$$\mathbf{Z}_L = \mathbf{Z}_T - \mathbf{Z}_{line} = (10.8 + j13) - (0.8 + j1) = 10 + j12 \Omega$$

Problem 10.22

An abc -sequence set of voltages feeds a balanced three-phase wye-wye system. If $\mathbf{V}_{an} = 440\angle 30^\circ$ V rms, $\mathbf{V}_{AN} = 413.28\angle 29.78^\circ$ V rms, and $\mathbf{Z}_{line} = 1.2 + j1.5 \Omega$, find the load impedance.

Suggested Solution

$$\mathbf{I}_a = \frac{\mathbf{V}_{an} - \mathbf{V}_{AN}}{\mathbf{Z}_{line}} = \frac{440\angle 30^\circ - 413.28\angle 29.78^\circ}{1.2 + j1.5} = 13.94\angle -17.93^\circ \text{ A rms}$$

$$\mathbf{Z}_{load} = \frac{\mathbf{V}_{AN}}{\mathbf{I}_a} = \frac{413.28\angle 29.78^\circ}{13.94\angle -17.93^\circ} = 19.95 + j21.93 \Omega$$

Problem 10.23

In a three-phase balanced positive-sequence system a delta-connected source supplies power to a wye-connected load. If the line impedance is $0.2 + j0.4 \Omega$, the load impedance $6 + j4 \Omega$, and the source phase voltage $\mathbf{V}_{ab} = 208\angle 40^\circ$ V rms, find the magnitude of the line voltage at the load.

Suggested Solution

$$\mathbf{V}_{ab} = 208\angle 40^\circ \text{ V rms} \quad \Rightarrow \quad \mathbf{V}_{an} = 120\angle 10^\circ \text{ V rms}$$

Then,

$$\mathbf{V}_{AN} = \frac{6 + j4}{6.2 + j4.4} (120\angle 10^\circ) = 113.8\angle 8.33^\circ \text{ V rms}$$

$$|\mathbf{V}_{AB}| = \sqrt{3} |\mathbf{V}_{AN}| = \sqrt{3} (113.8) = 197.28 \text{ V rms}$$

Problem 10.24

Given the network shown, compute the line currents and the magnitude of the phase voltage at the load.

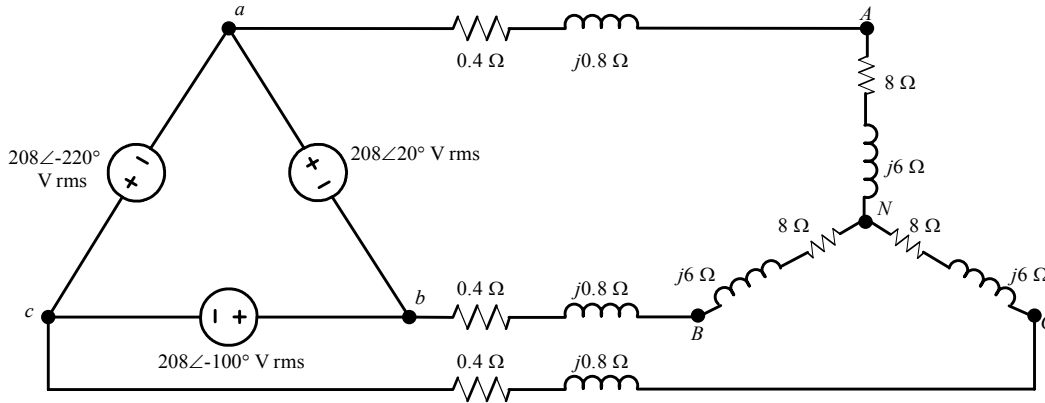

Suggested Solution

$$V_{ab} = 208\angle 20^\circ \text{ V rms}$$

$$Z_{line} = 0.4 + j0.8 \Omega$$

$$Z_Y = 8 + j6 \Omega$$

Per phase Y circuit:

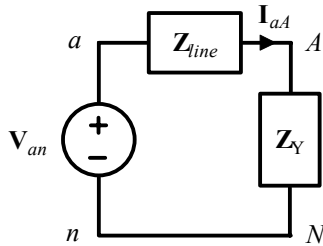

$$V_{an} = \frac{|V_{ab}|}{\sqrt{3}} \angle (\theta_{V_{ab}} - 30^\circ) = 120\angle -10^\circ \text{ V rms}$$

$$I_{aA} = \frac{V_{an}}{Z_{line} + Z_Y} = \frac{120\angle -10^\circ}{8.4 + j6.8} = 11.10\angle -49.00^\circ \text{ A rms}$$

$$I_{bB} = 11.10\angle -169^\circ \text{ A rms}$$

$$I_{cC} = 11.10\angle 71^\circ \text{ A rms}$$

$$|V_{AN}| = |I_{aA}| |Z_Y| = 11.10 \times |(8 + j6)| = 11.10 \times 10 = 111 \text{ V rms}$$

$$|V_{BN}| = |V_{CN}| = |V_{AN}| = 111 \text{ V rms}$$

Problem 10.25

In a balanced three-phase delta-wye system the source had an abc -phase sequence. The line and load impedances are $0.6 + j0.3 \Omega$ and $12 + j7 \Omega$, respectively. If the line current $\mathbf{I}_{aA} = 9.6 \angle -20^\circ$ A rms, determine the phase voltages of the source.

Suggested Solution

$$\mathbf{V}_{an} = (9.6 \angle -20^\circ)(12.6 + j7.3) = 139.78 \angle 10.09^\circ \text{ V rms}$$

$$\mathbf{V}_{ab} = 139.78 \sqrt{3} \angle (10.09^\circ + 30^\circ) = 242.11 \angle 40.09^\circ \text{ V rms}$$

$$\mathbf{V}_{bc} = 242.11 \angle (40.09^\circ - 120^\circ) = 242.11 \angle -79.91^\circ \text{ V rms}$$

$$\mathbf{V}_{ca} = 242.11 \angle (40.09^\circ + 120^\circ) = 242.11 \angle 160.09^\circ \text{ V rms}$$

Problem 10.26

An abc -phase-sequence three-phase balanced wye-connected 60-Hz source supplies a balanced delta-connected load. The phase impedance in the load consists of a $20\text{-}\Omega$ resistor in series with a 50-mH inductor, and the phase voltage at the source is $\mathbf{V}_{an} = 120\angle 20^\circ$ V rms. If the line impedance is zero, find the line currents in the system.

Suggested Solution

$$\mathbf{Z}_\Delta = 20 + j377(0.05)\ \Omega$$

$$\mathbf{Z}_{line} = 0\ \Omega$$

$$\mathbf{V}_{an} = 120\angle 20^\circ\ \text{V rms}$$

$$\Delta \rightarrow Y: \quad \mathbf{Z}_Y = \frac{\mathbf{V}_{AN}}{\mathbf{I}_{aA}} = \frac{\mathbf{V}_{AB}/\sqrt{3}}{\mathbf{I}_{AB}\sqrt{3}} = \frac{\mathbf{Z}_\Delta}{3} = 6.67 + j6.21\ \Omega$$

$$\mathbf{I}_{aA} = \frac{\mathbf{V}_{an}}{\mathbf{Z}_Y} \Rightarrow \mathbf{I}_{aA} = 13.10\angle -23.28^\circ\ \text{A rms}$$

$$\mathbf{I}_{bB} = 13.10\angle -143.28^\circ\ \text{A rms}$$

$$\mathbf{I}_{cC} = 13.10\angle 96.72^\circ\ \text{A rms}$$

Problem 10.27

An abc -phase-sequence three-phase balanced wye-connected source supplies a balanced delta-connected load. The impedance per phase in the delta load is $12 + j9 \Omega$. The line voltage at the source is $V_{ab} = 120\sqrt{3}\angle 40^\circ$ V rms. If the line impedance is zero, find the line currents in the balanced wye-delta system.

Suggested Solution

$$\mathbf{Z}_{line} = 0 \Rightarrow \mathbf{V}_{ab} = \mathbf{V}_{AB}$$

$$\mathbf{I}_{AB} = \frac{120\sqrt{3}\angle 40^\circ}{12 + j9} = 13.86\angle 3.13^\circ \text{ A rms}$$

$$\therefore \mathbf{I}_{aA} = 13.86\sqrt{3}\angle (3.13^\circ - 30^\circ) = 24.01\angle -26.87^\circ \text{ A rms ,}$$

$$\mathbf{I}_{bB} = 24.01\angle -146.87^\circ \text{ A rms , and}$$

$$\mathbf{I}_{cC} = 24.01\angle 93.13^\circ \text{ A rms}$$

Problem 10.28

An abc -phase-sequence three-phase balanced wye-connected source supplies power to a balanced delta-connected load. The impedance per phase in the load is $14 + j12 \Omega$. If the source voltage for the a phase is $\mathbf{V}_{an} = 120\angle 80^\circ$ V rms, and the line impedance is zero, find the phase currents in the wye-connected source.

Suggested Solution

$$\mathbf{V}_{an} = 120\angle 80^\circ \text{ V rms} \Rightarrow \mathbf{V}_{ab} = 120\sqrt{3}\angle 110^\circ \text{ V rms}$$

$$\mathbf{Z}_{line} = 0 \Rightarrow \mathbf{V}_{ab} = \mathbf{V}_{AB}$$

$$\mathbf{I}_{AB} = \frac{\mathbf{V}_{AB}}{\mathbf{Z}_{load}} = \frac{120\sqrt{3}\angle 110^\circ}{14 + j12} = 11.27\angle 69.4^\circ \text{ A rms},$$

$$\mathbf{I}_{bB} = 19.52\angle -80.6^\circ \text{ A rms and}$$

$$\mathbf{I}_{cC} = 19.52\angle 159.4^\circ \text{ A rms}$$

Problem 10.29

An abc -phase-sequence three-phase balanced wye-connected source supplies a balanced delta-connected load. The impedance per phase of the delta load is $10 + j8 \Omega$. If the line impedance is zero and the line current in the a phase is known to be $\mathbf{I}_{aA} = 28.10 \angle -28.66^\circ$ A rms, find the load voltage \mathbf{V}_{AB} .

Suggested Solution

If $\mathbf{I}_{aA} = 28.1 \angle -28.66^\circ$ A rms, then

$$\mathbf{I}_{AB} = \frac{28.1}{\sqrt{3}} \angle (-28.66^\circ + 30^\circ) = 16.22 \angle 1.34^\circ \text{ A rms}$$

$$\mathbf{V}_{AB} = \mathbf{I}_{AB} \cdot \mathbf{Z}_{\Delta} = (16.22 \angle 1.34^\circ)(10 + j8) = 207.8 \angle 40^\circ \text{ V rms}$$

Problem 10.30

An abc -phase-sequence three-phase balanced wye-connected source supplies power to a balanced delta-connected load. The impedance per phase of the delta load is $14 + j11 \Omega$. If the line impedance is zero and the line current in the a phase is $\mathbf{I}_{aA} = 20.22 \angle 31.84^\circ$ A rms, find the voltages of the balanced source.

Suggested Solution

$$\mathbf{Z}_Y = \frac{\mathbf{Z}_\Delta}{3} = \frac{14}{3} + j\frac{11}{3} = 5.93 \angle 38.2^\circ \Omega$$

$$\begin{aligned}\mathbf{V}_{an} &= \mathbf{I}_{aA} \cdot \mathbf{Z}_Y \\ &= (20.22 \angle 31.84^\circ)(5.93 \angle 38.2^\circ) \\ &= 120 \angle 70^\circ \text{ V rms}\end{aligned}$$

$$\mathbf{V}_{bn} = 120 \angle -50^\circ \text{ V rms}$$

$$\mathbf{V}_{cn} = 120 \angle 190^\circ \text{ V rms}$$

Problem 10.31

In a balanced three-phase wye-delta system, the source has an abc -phase sequence and $\mathbf{V}_{an} = 120\angle 0^\circ$ V rms. If the line current is $\mathbf{I}_{aA} = 4.8\angle 20^\circ$ A rms, find the load impedance per phase in the delta.

Suggested Solution

If $\mathbf{V}_{an} = 120\angle 0^\circ$, then $\mathbf{V}_{AB} = 120\sqrt{3}\angle 30^\circ$ V rms

and if $\mathbf{I}_{aA} = 4.8\angle 20^\circ$, then $\mathbf{I}_{AB} = \frac{4.8}{\sqrt{3}}\angle 50^\circ$ A rms

$$\therefore \mathbf{Z}_{load} = \frac{\mathbf{V}_{AB}}{\mathbf{I}_{AB}} = 70.48 - j25.65 \Omega$$

Problem 10.32

In a balanced three-phase wye-delta system, the source has an abc -phase sequence and $\mathbf{V}_{an} = 120\angle 40^\circ$ V rms. The line and load impedance are $0.5 + j0.4 \Omega$ and $24 + j18 \Omega$, respectively. Find the delta currents in the load.

Suggested Solution

Using $\Delta \rightarrow Y$ conversion, $\mathbf{Z}_Y = \frac{1}{3}\mathbf{Z}_\Delta = 8 + j6 \Omega$

$$\mathbf{I}_{aA} = \frac{120\angle 40^\circ}{8.5 + j6.4} = 11.28\angle 3.02^\circ \text{ A rms}$$

Then,

$$\mathbf{I}_{AB} = \frac{11.28}{\sqrt{3}} \angle (3.02^\circ + 30^\circ) = 6.51\angle 33.02^\circ \text{ A rms},$$

$$\mathbf{I}_{BC} = 6.51\angle -86.98^\circ \text{ A rms}, \text{ and}$$

$$\mathbf{I}_{CA} = 6.51\angle 153.02^\circ \text{ A rms}$$

Problem 10.33

In a three-phase balanced delta-delta system, the source has an abc -phase sequence. The line and load impedances are $0.3 + j0.2 \Omega$ and $9 + j6 \Omega$, respectively. If the load current in the delta is $\mathbf{I}_{AB} = 15\angle 40^\circ$ A rms, find the phase voltages of the source.

Suggested Solution

Converting to wye sources, $\mathbf{Z}_Y = \frac{\mathbf{Z}_\Delta}{3}$

$$\mathbf{I}_{aA} = 15\sqrt{3}\angle(40^\circ - 30^\circ) = 26\angle 10^\circ \text{ A rms}$$

$$\begin{aligned}\mathbf{V}_{an} &= (\mathbf{I}_{an})(\mathbf{Z}_{line} + \mathbf{Z}_Y) \\ &= (26\angle 10^\circ)(3.3 + j2.2) \\ &= 103\angle 43.7^\circ \text{ V rms}\end{aligned}$$

Then,

$$\begin{aligned}\mathbf{V}_{ab} &= 103\sqrt{3}\angle 73.7^\circ \\ &= 178.5\angle 73.7^\circ \text{ V rms},\end{aligned}$$

$$\mathbf{V}_{bc} = 178.5\angle -46.3^\circ \text{ V rms, and}$$

$$\mathbf{V}_{ca} = 178.5\angle 193.7^\circ \text{ V rms}$$

Problem 10.34

In a balanced three-phase delta-delta system, the source has an abc -phase sequence. The phase angle for the source voltage is $\angle \mathbf{V}_{ab} = 40^\circ$ and $\mathbf{I}_{ab} = 4\angle 15^\circ$ A rms. If the total power absorbed by the load is 1400 W, find the load impedance.

Suggested Solution

$$P_{L_{total}} = 1400 \text{ W} \quad \Rightarrow \quad P_\phi = \frac{1400}{3} = 466.67 \text{ W}$$

Since $\angle \mathbf{V}_{ab} = 40^\circ$ and $\mathbf{I}_{ab} = 4\angle 15^\circ$ A rms \Rightarrow No line impedance

$$P_\phi = |\mathbf{V}_{AB}| |\mathbf{I}_{AB}| \cos(40^\circ - 15^\circ)$$

$$|\mathbf{V}_{AB}| = \frac{466.67}{4 \cos 25^\circ} = 128.73 \text{ V rms}$$

$$\mathbf{Z}_L = \frac{\mathbf{V}_{AB}}{\mathbf{I}_{AB}} = \frac{128.73\angle 40^\circ}{4\angle 15^\circ} = 32.18\angle 25^\circ \Omega$$

Problem 10.35

A three-phase load impedance consists of a balanced wye in parallel with a balanced delta. What is the equivalent wye load and what is the equivalent delta load if the phase impedance of the wye and delta are $6 + j3 \Omega$ and $15 + j12 \Omega$, respectively?

Suggested Solution

Equivalent Y:

$$\mathbf{Z}'_Y = \frac{\mathbf{Z}'_\Delta}{3}$$

$$\mathbf{Z}'_{total} = \frac{(6 + j3)(5 + j4)}{(6 + j3) + (5 + j4)} = \frac{18 + j39}{11 + j7} = 2.77 + j1.78 \Omega$$

Equivalent Δ :

$$\mathbf{Z}_\Delta = 3\mathbf{Z}'_Y = 3(2.77 + j1.78) = 8.31 + j5.34 \Omega$$

Problem 10.36

In a balanced three-phase system, the abc -phase-sequence source is wye connected and $\mathbf{V}_{an} = 120\angle 20^\circ$ V rms. The load consists of two balanced wyes with phase impedances of $8 + j6 \Omega$ and $12 + j8 \Omega$. If the line impedance is zero, find the line currents and the phase currents in each load.

Suggested Solution

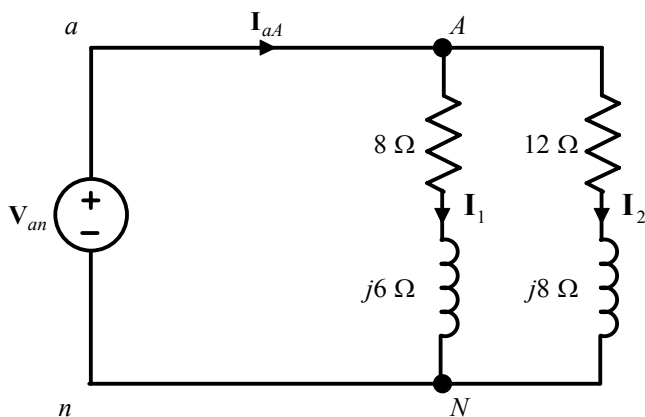

$$\mathbf{I}_1 = \frac{120\angle 20^\circ}{8 + j6} = 12\angle -16.87^\circ \text{ A rms}$$

$$\mathbf{I}_2 = \frac{120\angle 20^\circ}{12 + j8} = 8.32\angle -13.69^\circ \text{ A rms}$$

$$\mathbf{I}_{aA} = \mathbf{I}_1 + \mathbf{I}_2 = 20.3\angle -15.57^\circ \text{ A rms}$$

The other currents are shifted by -120° and -240°

Problem 10.37

In a balanced three-phase system, the source is a balanced wye with an abc -phase sequence and $V_{ab} = 208\angle 60^\circ$ V rms. The load consists of a balanced wye with a phase impedance of $8 + j5 \Omega$ in parallel with a balanced delta with a phase impedance of $21 + j12 \Omega$. If the line impedance is $1.2 + j1 \Omega$, find the phase currents in the balanced wye load.

Suggested Solution

Converting Z_Δ to Z'_Y : $Z'_Y = 7 + j4 \Omega$

Then, $Z_L = (8 + j5) \parallel (7 + j4) = 4.35\angle 30.8^\circ \Omega$

$$V_{ab} = 208\angle 60^\circ \text{ V rms} \quad \Rightarrow \quad V_{an} = \frac{208}{\sqrt{3}} \angle (60^\circ - 30^\circ) = 120\angle 30^\circ \text{ V rms}$$

$$I_{aA} = \frac{V_{an}}{Z_L + Z_{line}} = \frac{120\angle 30^\circ}{5.9\angle 33.2^\circ} = 20.3\angle -3.2^\circ \text{ A rms}$$

$$V_{AN} = I_{aA} Z_L = (20.3\angle -3.2^\circ)(4.35\angle 30.8^\circ) = 88.4\angle 27.6^\circ \text{ V rms}$$

$$I_{AN} = \frac{V_{AN}}{Z_Y} = \frac{88.4\angle 27.6^\circ}{8 + j5} = 9.37\angle -4.4^\circ \text{ A rms}$$

$$I_{BN} = 9.37\angle 115.6^\circ \text{ A rms}$$

$$I_{CN} = 9.37\angle -124.4^\circ \text{ A rms}$$

Problem 10.38

In a balanced three-phase system, the source is a balanced wye with an abc -phase sequence and $V_{ab} = 208\angle 50^\circ$ V rms. The load is a balanced wye in parallel with a balanced delta. The phase impedance of the wye is $5 + j3 \Omega$ and the phase impedance of the delta is $18 + j12 \Omega$. If the line impedance is $1 + j0.8 \Omega$, find the line currents and the phase currents in the loads.

Suggested Solution

$$Z'_Y = \frac{Z_\Delta}{3} = 6 + j4 \Omega$$

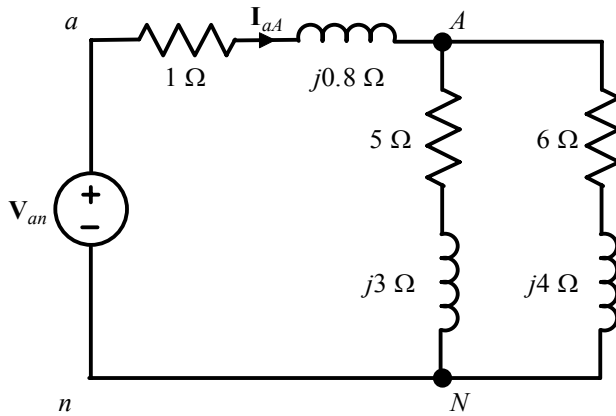

$$V_{an} = \frac{208}{\sqrt{3}} \angle (50^\circ - 30^\circ) = 120 \angle 20^\circ \text{ V rms}$$

$$Z_L = \frac{(5 + j3)(6 + j4)}{(5 + j3) + (6 + j4)} = 3.22 \angle 32.18^\circ \Omega$$

$$I_{aA} = \frac{120 \angle 20^\circ}{Z_{line} + Z_L} = \frac{120 \angle 20^\circ}{4.5 \angle 33.94^\circ} = 26.67 \angle -13.94^\circ \text{ A rms}$$

$$V_{AN} = I_{aA} Z_{load} = 85.88 \angle 18.24^\circ \text{ V rms}$$

$$Y_{load} : I_{AN} = \frac{V_{AN}}{5 + j3} = 14.73 \angle -12.72^\circ \text{ A rms}$$

$$\Delta_{load} : V_{AB} = 85.88\sqrt{3} \angle 48.24^\circ \text{ V rms} \quad \Rightarrow \quad I_{AB} = \frac{V_{AB}}{18 + j12} = 6.88 \angle 14.55^\circ \text{ A rms}$$

The other currents are shifted by -120° and -240°

Problem 10.39

In a balanced three-phase system the source, which has an abc -phase sequence, is connected in delta and $V_{ab} = 208\angle 55^\circ$ V rms. There are two loads connected in parallel. Load 1 is connected in wye and the phase impedance is $4 + j3 \Omega$. Load 2 is connected in wye and the phase impedance is $8 + j6 \Omega$. Compute the delta currents in the source if the line impedance connecting the source to the loads is $0.2 + j0.1 \Omega$.

Suggested Solution

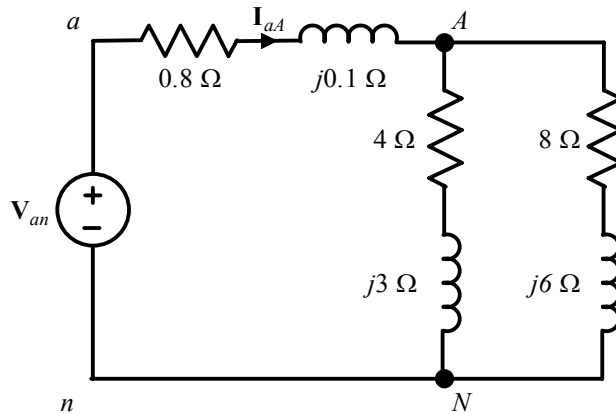

$$V_{an} = \frac{208}{\sqrt{3}} \angle (55^\circ - 30^\circ) = 120 \angle 25^\circ \text{ V rms}$$

$$Z_L = \frac{(4 + j3)(8 + j6)}{(4 + j3) + (8 + j6)} = 3.33 \angle 36.87^\circ = 2.66 + j2.0 \Omega$$

$$I_{aA} = \frac{120 \angle 25^\circ}{Z_{line} + Z_L} = \frac{120 \angle 25^\circ}{2.86 + j2.1} = 33.8 \angle -11.29^\circ \text{ A rms}$$

$$I_{ba} = \frac{33.8}{\sqrt{3}} \angle (-11.29^\circ + 30^\circ) = 19.51 \angle 18.71^\circ \text{ A rms}$$

$$I_{cb} = 19.51 \angle (18.71^\circ - 120^\circ) = 19.51 \angle -101.29^\circ \text{ A rms}$$

$$I_{ac} = 19.51 \angle (18.71^\circ - 240^\circ) = 19.51 \angle -221.29^\circ \text{ A rms}$$

Problem 10.40

In a balanced three-phase system, the source has an *abc*-phase sequence and is connected in delta. There are two parallel wye-connected loads. The phase impedance of load 1 and load 2 is $4 + j4\Omega$ and $10 + j4\Omega$, respectively. The line impedance connecting the source to the loads is $0.3 + j0.2\Omega$. If the current in the *a* phase of load 1 is $\mathbf{I}_{AN_1} = 10\angle 20^\circ$ A rms, find the delta currents in the source.

Suggested Solution

By current division:

$$\mathbf{I}_{AN_1} = \mathbf{I}_{aA} \cdot \frac{10 + j4}{(4 + j4) + (10 + j4)} \Rightarrow \mathbf{I}_{aA} = 15\angle 27.9^\circ \text{ A rms}$$

Then, since a source:

$$\mathbf{I}_{ab} = -\frac{|\mathbf{I}_{aA}|}{\sqrt{3}} \angle (\theta + 30^\circ) = \frac{15}{\sqrt{3}} \angle -122.1^\circ = 8.64\angle -122.1^\circ \text{ A rms}$$

$$\mathbf{I}_{bc} = 8.64\angle -242.1^\circ \text{ A rms}$$

$$\mathbf{I}_{ca} = 8.64\angle -2.1^\circ \text{ A rms}$$

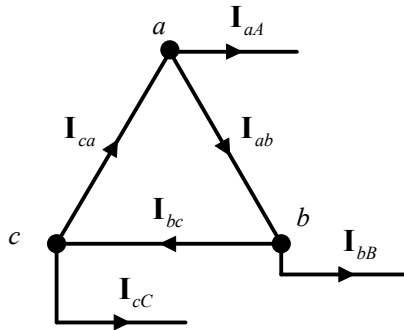

Problem 10.41

In a balanced three-phase system, the source has an abc -phase sequence and is connected in delta. There are two loads connected in parallel. The line connecting the source to the loads has an impedance of $0.2 + j0.1 \Omega$. Load 1 is connected in wye and the phase impedance is $4 + j2 \Omega$. Load 2 is connected in delta, and the phase impedance is $12 + j9 \Omega$. The current \mathbf{I}_{AB} in the delta load is $16\angle 45^\circ$ A rms. Find the phase voltages of the source.

Suggested Solution

The Y equivalent circuit is:

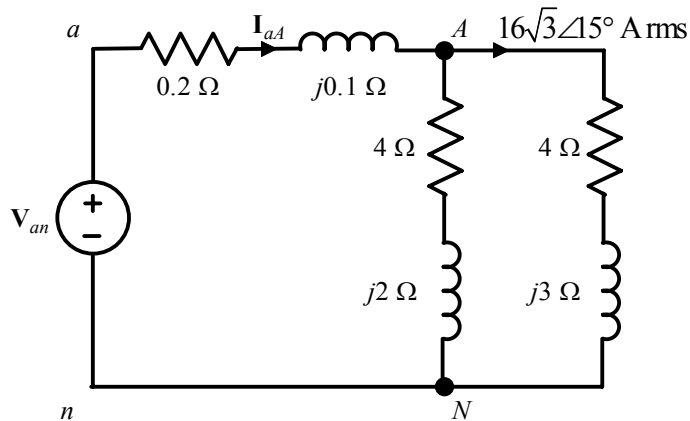

Using current division:

$$\frac{\mathbf{I}_{aA}(4 + j2)}{8 + j5} = 16\sqrt{3}\angle 15^\circ \quad \Rightarrow \quad \mathbf{I}_{aA} = 58.43\angle 20.44^\circ \text{ A rms}$$

$$\mathbf{V}_{an} = \mathbf{I}_{aA}(0.2 + j0.1) + (16\sqrt{3}\angle 15^\circ)(4 + j3) = 151.36\angle 51.46^\circ \text{ V rms}$$

$$\therefore \quad \mathbf{V}_{ab} = 262.16\angle 81.46^\circ \text{ V rms},$$

$$\mathbf{V}_{bc} = 262.16\angle -38.54^\circ \text{ V rms}, \text{ and}$$

$$\mathbf{V}_{ca} = 262.16\angle -158.54^\circ \text{ V rms}$$

Problem 10.42

In a balanced three-phase system, the source has an abc -phase sequence and is connected in delta. There are two loads connected in parallel. Load 1 is connected in wye and has a phase impedance of $6 + j2 \Omega$. Load 2 is connected in delta and has a phase impedance of $9 + j3 \Omega$. The line impedance is $0.4 + j0.3 \Omega$. Determine the phase voltages of the source if the current in the a phase of load 1 is $\mathbf{I}_{AN_1} = 12\angle 30^\circ$ A rms.

Suggested Solution

The Y equivalent circuit is:

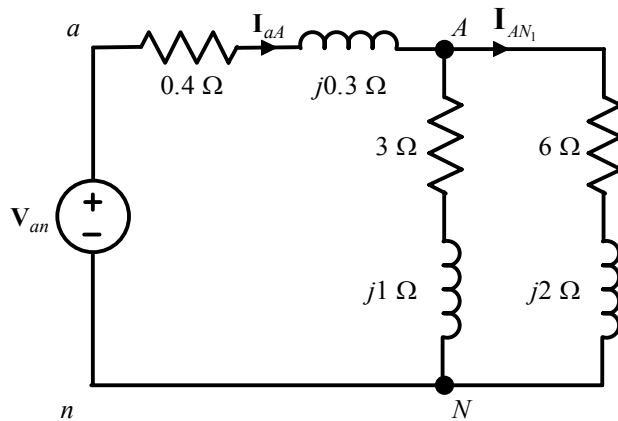

Using current division:

$$\frac{\mathbf{I}_{aA}(3 + j1)}{9 + j3} = 12\angle 30^\circ \text{ A rms} \quad \Rightarrow \quad \mathbf{I}_{aA} = 36\angle 30^\circ \text{ A rms}$$

$$\mathbf{V}_{an} = (\mathbf{I}_{aA})(0.4 + j0.3) + (12\angle 30^\circ)(6 + j2) = 93.14\angle 51.93^\circ \text{ V rms}$$

$$\mathbf{V}_{ab} = 93.14\sqrt{3}\angle(51.93^\circ + 30^\circ) = 161.32\angle 81.93^\circ \text{ V rms}$$

$$\mathbf{V}_{bc} = 161.32\angle(81.93^\circ - 120^\circ) = 161.32\angle -38.07^\circ \text{ V rms}$$

$$\mathbf{V}_{ca} = 161.32\angle(81.93^\circ - 240^\circ) = 161.32\angle -158.07^\circ \text{ V rms}$$

Problem 10.43

A balanced three-phase delta-connected source supplies power to a load consisting of a balanced delta in parallel with a balanced wye. The phase impedance of the delta is $24 + j12 \Omega$, and the phase impedance of the wye is $12 + j8 \Omega$. The abc -phase-sequence source voltages are $\mathbf{V}_{ab} = 440\angle 60^\circ$ V rms, $\mathbf{V}_{bc} = 440\angle -60^\circ$ V rms and $\mathbf{V}_{ca} = 440\angle -180^\circ$ V rms, and the line impedance per phase is $1 + j0.8 \Omega$. Find the line currents and the power absorbed by the wye-connected load.

Suggested Solution

$$\mathbf{V}_{ab} = 440\angle 60^\circ \text{ V rms} \quad \Rightarrow \quad \mathbf{V}_{an} = \frac{440}{\sqrt{3}} \angle (60^\circ - 30^\circ) = 254\angle 30^\circ \text{ V rms}$$

Equivalent single-phase (a -phase) diagram:

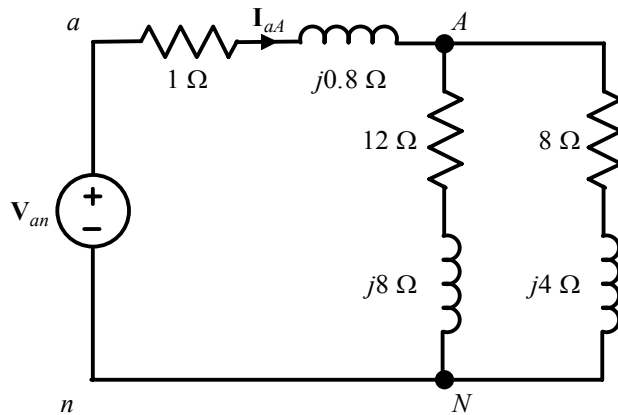

$$\mathbf{Z}_L = \frac{(12 + j8)(8 + j4)}{20 + j12} = 5.54\angle 29.3^\circ \Omega$$

$$\mathbf{Z}_T = \mathbf{Z}_{line} + \mathbf{Z}_L = 6.8\angle 30.9^\circ \Omega$$

$$\mathbf{I}_{aA} = \frac{254\angle 30^\circ}{6.8\angle 30.9^\circ} = 37.35\angle -1^\circ \text{ A rms} \quad \Rightarrow \quad \mathbf{I}_{bB} = 37.35\angle -121^\circ \text{ A rms} \quad \text{and} \quad \mathbf{I}_{cC} = 37.35\angle 119^\circ \text{ A rms}$$

$$\mathbf{V}_{AN} = \mathbf{I}_{aA} \mathbf{Z}_L = 206.93\angle 28.3^\circ \text{ V rms}$$

$$\mathbf{I}_{AN-Y} = \frac{\mathbf{V}_{AN}}{\mathbf{Z}_Y} = \frac{206.93\angle 28.3^\circ}{12 + j8} = 14.37\angle -5.4^\circ \text{ A rms}$$

$$P_{Y,load} = 3(14.37)^2 (12) = 7.434 \text{ kW}$$

Problem 10.44

An abc -sequence wye-connected source having a phase- a voltage of $120\angle 0^\circ$ V rms is attached to a wye-connected load having an impedance of $80\angle 70^\circ \Omega$. If the line impedance is $4\angle 20^\circ \Omega$, determine the total complex power produced by the voltage source and the real and reactive power dissipated by the load.

Suggested Solution

$$\mathbf{I}_{aA} = \frac{120\angle 0^\circ}{80\angle 70^\circ + 4\angle 20^\circ} = \frac{120\angle 0^\circ}{31.12 + j76.55} = 1.45\angle -67.88^\circ \text{ A rms}$$

$$\mathbf{V}_L = \mathbf{I}_{aA} \mathbf{Z}_Y = (1.45\angle -67.88^\circ)(80\angle 70^\circ) = 116.18\angle 2.12^\circ \text{ V rms}$$

$$\mathbf{S}_{\phi,S} = \mathbf{V} \mathbf{I}^* = (120\angle 0^\circ)(1.45\angle 67.88^\circ) = 174\angle 67.88^\circ \text{ VA}$$

$$\mathbf{S}_{T,S} = 3\mathbf{S}_{\phi,S} = 522\angle 67.88^\circ \text{ VA}$$

$$\mathbf{S}_{\phi,L} = (116.18\angle 2.12^\circ)(1.45\angle 62.88^\circ) = 168.46\angle 70^\circ = 57.62 + j158.30 \text{ VA}$$

$$\mathbf{S}_L = 3\mathbf{S}_{\phi,L} = 505.38\angle 70^\circ = 172.86 + j474.9 \text{ VA}$$

$$\Rightarrow P_L = 172.86 \text{ W} \quad \text{and} \quad Q_L = 474.9 \text{ VAR}$$

Problem 10.45

The magnitude of the complex power (apparent power) supplied by a three-phase balanced wye-wye system is 3600 VA. The line voltage is 208 V rms. If the line impedance is negligible and the power factor angle of the load is 25° , determine the load impedance.

Suggested Solution

$$|S| = \sqrt{3} V_L I_L \Rightarrow I_L = \frac{3600}{208\sqrt{3}} = 9.99 \text{ A rms}$$

$$Z_Y = \frac{208/\sqrt{3}}{9.99} \angle 25^\circ = \frac{120}{9.99} \angle 25^\circ = 12.01 \angle 25^\circ = 10.88 + j5.08 \Omega$$

Problem 10.46

A balanced three-phase wye-wye system has two parallel loads. Load 1 is rated at 3000 VA, 0.7 pf lagging, and load 2 is rated at 2000 VA, 0.75 pf leading. If the line voltage is 208 V rms, find the magnitude of the line current.

Suggested Solution

$$\mathbf{S}_1 = 3000 \angle \cos^{-1}(0.7) = 3000 \angle 45.57^\circ = 2100 + j2142.43 \text{ VA}$$

$$\mathbf{S}_2 = 2000 \angle -\cos^{-1}(0.75) = 2000 \angle -41.41^\circ = 1500 - j1322.88 \text{ VA}$$

$$\mathbf{S}_T = \mathbf{S}_1 + \mathbf{S}_2 = 3600 + j819.55 = 3692.11 \angle 12.82^\circ \text{ VA}$$

$$|\mathbf{I}_L| = \frac{3692.11}{208\sqrt{3}} = 10.25 \text{ A rms}$$

Problem 10.47

Two industrial plants represent balanced three-phase loads. The plants receive their power from a balanced three-phase source with a line voltage of 4.6 kV rms. Plant 1 is rated at 300 kVA, 0.8 pf lagging and plant 2 is rated at 350 kVA, 0.84 pf lagging. Determine the power line current.

Suggested Solution

$$\mathbf{S}_1 = 300 \angle \cos^{-1}(0.8) = 300 \angle 36.87^\circ = 240 + j180 \text{ kVA}$$

$$\mathbf{S}_2 = 350 \angle \cos^{-1}(0.84) = 350 \angle 32.86^\circ = 294 + j189.9 \text{ kVA}$$

$$\mathbf{S}_T = \mathbf{S}_1 + \mathbf{S}_2 = 534 + j369.9 = 649.6 \angle 34.71^\circ \text{ kVA}$$

$$|\mathbf{I}_L| = \frac{649.6}{4.6\sqrt{3}} = 81.53 \text{ A rms}$$

Problem 10.48

A cluster of loads is served by a balanced three-phase source with a line voltage of 4160 V rms. Load 1 is 240 kVA at 0.8 pf lagging and load 2 is 160 kVA at 0.92 pf lagging. A third load is unknown except that it has a power factor of unity. If the line current is measured and found to be 62 A rms, find the complex power of the unknown load.

Suggested Solution

$$|\mathbf{S}_T| = \sqrt{3} V_L I_L = \sqrt{3} (4160)(62) = 446730.54 \text{ VA}$$

$$\mathbf{S}_1 = 240 \angle \cos^{-1}(0.8) = 192000 + j144000 \text{ VA}$$

$$\mathbf{S}_2 = 160 \angle \cos^{-1}(0.92) = 147200 + j62707 \text{ VA}$$

$$|(192000 + 147200 + P_3) + j(144000 + 62707 + 0)| = |\mathbf{S}_T|$$

$$\Rightarrow \sqrt{(339200 + P_3)^2 + (206707)^2} = 446730.54$$

$$\therefore P_3 = 56831 \text{ W}$$

$$\mathbf{S}_3 = P_3 + j0 = 56831 \angle 0^\circ \text{ VA}$$

Problem 10.49

A balanced three-phase source serves two loads:

Load 1: 36 kVA at 0.8 pf lagging

Load 2: 18 kVA at 0.6 pf lagging

The line voltage at the load is 208 V rms at 60 Hz. Find the line current and the combined power factor at the load.

Suggested Solution

$$V_{ab} = 208 \text{ V rms}$$

$$\mathbf{S}_1 = 36 \angle \cos^{-1}(0.8) = 36 \angle 36.87^\circ = 28.8 + j21.6 \text{ kVA}$$

$$\mathbf{S}_2 = 18 \angle \cos^{-1}(0.6) = 18 \angle 53.13^\circ = 10.8 + j14.4 \text{ kVA}$$

$$\mathbf{S}_L = \mathbf{S}_1 + \mathbf{S}_2 = 39.6 + j36.0 = 53.52 \angle 42.27^\circ \text{ kVA}$$

$$|\mathbf{S}_L| = \sqrt{3} V_{ab} I_{aA} \quad \Rightarrow \quad |I_{aA}| = \frac{53.52 \times 10^3}{208\sqrt{3}} = 148.56 \text{ A rms}$$

$$pf_L = \cos \theta = \cos(42.27^\circ) = 0.74 \text{ lagging}$$

Problem 10.50

A balanced three-phase source serves the following loads:

Load 1: 48 kVA at 0.9 pf lagging

Load 2: 24 kVA at 0.75 pf lagging

The line voltage at the load is 208 V rms at 60 Hz. Determine the line current and the combined power factor at the load.

Suggested Solution

$$V_{ab} = 208 \text{ V rms}$$

$$\mathbf{S}_1 = 48 \angle \cos^{-1}(0.9) = 48 \angle 25.84^\circ = 43.2 + j20.92 \text{ kVA}$$

$$\mathbf{S}_2 = 24 \angle \cos^{-1}(0.75) = 24 \angle 41.41^\circ = 18 + j15.87 \text{ kVA}$$

$$\mathbf{S}_L = \mathbf{S}_1 + \mathbf{S}_2 = 61.2 + j36.79 = 71.41 \angle 31.02^\circ \text{ kVA}$$

$$|\mathbf{S}_L| = \sqrt{3} V_{ab} I_{aA} \quad \Rightarrow \quad |I_{aA}| = \frac{71.41 \times 10^3}{208 \sqrt{3}} = 198.21 \text{ A rms}$$

$$pf_L = \cos \theta = \cos(31.02^\circ) = 0.86 \text{ lagging}$$

Problem 10.51

A small shopping center contains three stores that represent three balanced three-phase loads. The power lines to the shopping center represent a three-phase source with a line voltage of 13.8 kV rms. The three loads are:

Load 1: 500 kVA at 0.8 pf lagging

Load 2: 400 kVA at 0.85 pf lagging

Load 3: 300 kVA at 0.90 pf lagging

Find the magnitude of the power line current.

Suggested Solution

$$V_{ab} = 13.8 \text{ kV rms}$$

$$S_1 = 500 \angle \cos^{-1}(0.8) = 500 \angle 36.87^\circ = 400 + j300 \text{ kVA}$$

$$S_2 = 400 \angle \cos^{-1}(0.85) = 400 \angle 31.79^\circ = 340 + j210.72 \text{ kVA}$$

$$S_3 = 300 \angle \cos^{-1}(0.9) = 300 \angle 25.84^\circ = 270 + j130.76 \text{ kVA}$$

$$S_T = S_1 + S_2 + S_3 = 1010 + j641.48 = 1196.5 \angle 32.42^\circ \text{ kVA}$$

$$|S_T| = \sqrt{3} V_{ab} I_{aA} \Rightarrow |I_{aA}| = \frac{1196.5}{13.8\sqrt{3}} = 50.1 \text{ A rms}$$

Problem 10.52

The following loads are served by a balanced three-phase source:

Load 1: 18 kVA at 0.8 pf lagging

Load 2: 8 kVA at 0.8 pf leading

Load 3: 12 kVA at 0.75 pf lagging

The load voltage is 208 V rms at 60 Hz. If the line impedance is negligible, find the power factor of the source.

Suggested Solution

$$\mathbf{S}_1 = 18 \angle \cos^{-1}(0.8) = 18 \angle 36.87^\circ = 14.40 + j10.80 \text{ kVA}$$

$$\mathbf{S}_2 = 8 \angle -\cos^{-1}(0.8) = 8 \angle -36.87^\circ = 6.40 - j4.80 \text{ kVA}$$

$$\mathbf{S}_3 = 12 \angle \cos^{-1}(0.75) = 12 \angle 41.41^\circ = 9.00 + j7.94 \text{ kVA}$$

$$\mathbf{S}_T = \mathbf{S}_1 + \mathbf{S}_2 + \mathbf{S}_3 = 29.80 + j13.94 = 32.90 \angle 25.07^\circ \text{ kVA}$$

$$pf = \cos \theta = \cos(25.07^\circ) = 0.91 \text{ lagging}$$

Problem 10.53

A balanced three-phase source supplies power to three loads. The loads are:

Load 1: 30 kVA at 0.8 pf lagging

Load 2: 24 kW at 0.6 pf leading

Load 3: unknown

If the line voltage and total complex power at the load are 208 V rms and $60\angle 0^\circ$ kVA, respectively, find the unknown load.

Suggested Solution

$$V_{AB} = 208 \text{ V rms} \quad \text{pf at source} = 1.0$$

$$S_T = \sqrt{3} V_{AB} I_{aA} \angle \cos^{-1}(1.0) = 60.0 \angle 0^\circ \text{ kVA} \quad \Rightarrow \quad I_{aA} = \frac{60 \times 10^3}{208 \sqrt{3}} = 166.8 \text{ A rms}$$

$$S_1 = 30 \angle \cos^{-1}(0.8) = 30 \angle 36.87^\circ = 24 + j18 \text{ kVA}$$

$$S_2 = \frac{24}{0.6} \angle -\cos^{-1}(0.6) = 40 \angle -53.13^\circ = 24 - j32 \text{ kVA}$$

$$P_T = P_1 + P_2 + P_3 \quad \Rightarrow \quad P_3 = 60.0 - 24 - 24 = 12.0 \text{ kW}$$

$$Q_T = Q_1 + Q_2 + Q_3 \quad \Rightarrow \quad Q_3 = 0 - 18 + 32 = 14 \text{ kVAR}$$

$$S_3 = 12.0 + j14 \text{ kVA} = 18.44 \text{ kVA at } 0.65 \text{ pf lagging}$$

Problem 10.54

A balanced three-phase source serves the following loads:

Load 1: 18 kVA at 0.8 pf lagging

Load 2: 10 kVA at 0.7 pf leading

Load 3: 12 kW at unity pf

Load 4: 16 kVA at 0.6 pf lagging

The magnitude of the line voltage at the load is 208 V rms at 60 Hz, and the line impedance is $0.02 + j0.04 \Omega$. Find the magnitude of the line voltage and power factor at the source.

Suggested Solution

$$|V_{AB}| = 208 \text{ V rms} \quad Z_{line} = 0.02 + j0.04 \Omega$$

$$S_1 = 18 \angle \cos^{-1}(0.8) = 18 \angle 36.87^\circ = 14.4 + j10.8 \text{ kVA}$$

$$S_2 = 10 \angle -\cos^{-1}(0.7) = 10 \angle -45.57^\circ = 7.0 - j7.14 \text{ kVA}$$

$$S_3 = \frac{12}{1.0} \angle 0^\circ = 12 \angle 0^\circ = 12 + j0 \text{ kVA}$$

$$S_4 = 16 \angle \cos^{-1}(0.6) = 16 \angle 53.13^\circ = 9.6 + j12.8 \text{ kVA}$$

$$S_L = S_1 + S_2 + S_3 + S_4 = 43 + j16.46 = 46.04 \angle 20.95^\circ \text{ kVA}$$

$$S_L = 3 \frac{V_{AN}^2}{Z_L^*} \Rightarrow Z_L = \left(3 \frac{V_{AN}^2}{S_L} \right)^* \quad V_{AN} = \frac{V_{AB}}{\sqrt{3}} = \frac{208}{\sqrt{3}} = 120 \text{ V rms}; \quad \text{Let } \angle V_{AN} = 0^\circ$$

$$\text{Then, } Z_L = \left[3 \frac{(V_{AN} \angle 0^\circ)^2}{S_L} \right]^* = \left(3 \frac{V_{AN}^2}{S_L} \right) = \left(3 \frac{120^2}{46.04 \angle -20.95^\circ} \right) = 0.94 \angle 20.95^\circ = 0.88 + j0.34 \Omega$$

Per-phase Y circuit:

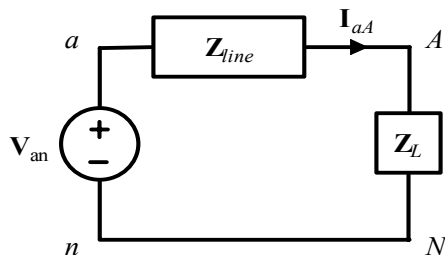

$$I_{aA} = \frac{V_{AN}}{Z_L} = \frac{120 \angle 0^\circ}{0.94 \angle 20.95^\circ} = 127.66 \angle -20.95^\circ \text{ A rms}$$

$$V_{an} = I_{aA} [Z_{line} + Z_L] = 124.72 \angle 1.94^\circ \text{ V rms}$$

$$|V_{ab}| = \sqrt{3} |V_{an}| = 216.02 \text{ V rms}$$

$$pf = \cos(\theta_{V_{an}} - \theta_{I_{aA}}) = \cos(22.89^\circ) = 0.92 \text{ lagging}$$

Problem 10.55

A balanced three-phase source supplies power to three loads. The loads are:

Load 1: 18 kW at 0.8 pf lagging

Load 2: 10 kVA at 0.6 pf leading

Load 3: unknown

If the line voltage at the load is 208 V rms, the magnitude of the total complex power is 41.93 kVA and the combined power factor at the load is 0.86 lagging, find the unknown load.

Suggested Solution

$$V_{AB} = 208 \text{ V rms}$$

$$pf_L = 0.86 \text{ lagging}$$

$$|S_L| = \sqrt{3} V_{AB} I_{aA} = 41.93 \text{ kVA} \quad \Rightarrow \quad I_{aA} = \frac{41.93 \times 10^3}{208\sqrt{3}} = 116.39 \text{ A rms}$$

$$\theta_{S_L} = \cos^{-1}(0.86) = 30.68^\circ$$

$$S_L = 41.93 \angle 30.68^\circ = 36.06 + j21.40 \text{ kVA} = S_1 + S_2 + S_3$$

$$S_1 = \frac{18}{0.8} \angle \cos^{-1}(0.8) = 22.5 \angle 36.87^\circ = 18 + j13.5 \text{ kVA}$$

$$S_2 = 10 \angle -\cos^{-1}(0.6) = 10 \angle -53.13^\circ = 6 - j8 \text{ kVA}$$

$$\begin{aligned} S_3 &= S_L - S_1 - S_2 \\ &= (36.06 + j21.40) - (18 + j13.5) - (6 - j8) \\ &= 12.06 + j15.9 \text{ kVA} \\ &= 19.96 \text{ kVA at } 0.60 \text{ pf lagging} \end{aligned}$$

Problem 10.56

A balanced three-phase source supplies power to three loads. The loads are:

Load 1: 20 kVA at 0.6 pf lagging

Load 2: 12 kW at 0.75 pf lagging

Load 3: unknown

If the line voltage at the load is 208 V rms, the magnitude of the total complex power is 35.52 kVA and the combined power factor at the load is 0.88 lagging, find the unknown load.

Suggested Solution

$$V_{AB} = 208 \text{ V rms}$$

$$pf_L = 0.88 \text{ lagging}$$

$$|S_L| = \sqrt{3} V_{AB} I_{aA} = 35.52 \text{ kVA} \quad \Rightarrow \quad I_{aA} = \frac{35.52 \times 10^3}{208\sqrt{3}} = 98.6 \text{ A rms}$$

$$\theta_{S_L} = \cos^{-1}(0.88) = 28.36^\circ$$

$$S_L = 35.52 \angle 28.36^\circ = 31.26 + j16.87 \text{ kVA} = S_1 + S_2 + S_3$$

$$S_1 = 20 \angle \cos^{-1}(0.6) = 20 \angle 53.13^\circ = 12 + j16 \text{ kVA}$$

$$S_2 = \frac{12}{0.75} \angle \cos^{-1}(0.75) = 16 \angle 41.41^\circ = 12 + j10.58 \text{ kVA}$$

$$\begin{aligned} S_3 &= S_L - S_1 - S_2 \\ &= (31.26 + j16.87) - (12 + j16) - (12 + j10.58) \\ &= 7.26 - j9.71 \text{ kVA} \\ &= 12.13 \text{ kVA at } 0.60 \text{ pf leading} \end{aligned}$$

Problem 10.57

A standard practice for utility companies is to divide its customers into single-phase users and three-phase users. The utility must provide three-phase users, typically industries, with all three phases. However, single-phase users, residential and light commercial, are connected to only one phase. To reduce cable costs, all single-phase users in a neighborhood are connected together. This means that even if the three-phase users present perfectly balanced loads to the power grid, the single-phase loads will never be in balance, resulting in current flow in the neutral connection.

Consider the 60-Hz, *abc*-sequence network shown. With a line voltage of $416\angle 30^\circ$ V rms, phase *a* supplies the single-phase users on A Street, phase *b* supplies B Street and phase *c* supplies C Street. Furthermore, the three-phase industrial load, which is connected in delta, is balanced. Find the neutral current.

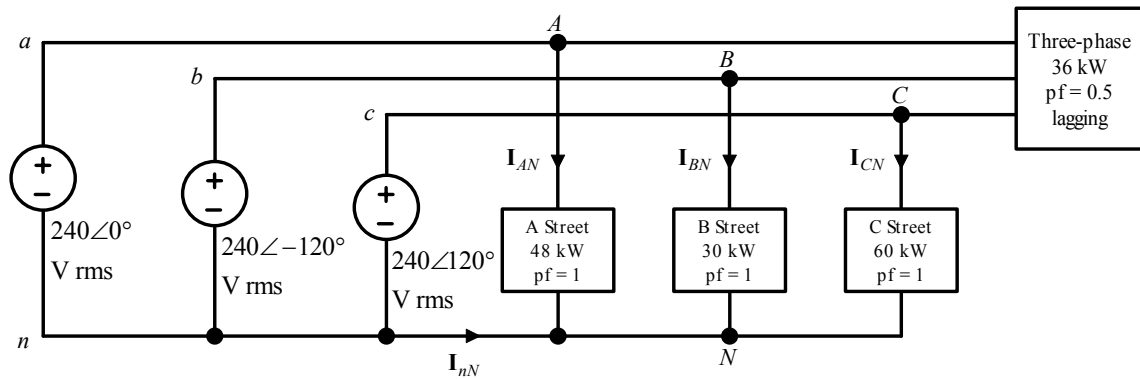

Suggested Solution

$$P_A = 48,000 = V_{an} I_{AN}$$

$$I_{AN} = \frac{P_A}{V_{an}} = 200\angle 0^\circ \text{ A rms}$$

$$I_{BN} = \frac{P_B}{V_{BN}} = 125\angle -120^\circ \text{ A rms}$$

$$I_{CN} = \frac{P_C}{V_{CN}} = 250\angle -240^\circ \text{ A rms}$$

$$\begin{aligned} I_{nN} &= I_{AN} + I_{BN} + I_{CN} \\ &= 108.97\angle 83.41^\circ \text{ A rms} \end{aligned}$$

$$\therefore I_{nN} = 108.97\angle -96.59^\circ \text{ A rms}$$

Problem 10.58

A three-phase *abc*-sequence wye-connected source with $V_{an} = 220\angle 0^\circ$ V rms supplies power to a wye-connected load that consumes 150 kW of power at a pf of 0.8 lagging. Three capacitors are found that each have an impedance of $-j2.0 \Omega$, and they are connected in parallel with the previous load in a wye configuration. Determine the power factor of the combined load as seen by the source.

Suggested Solution

$$V_{an} = 220\angle 0^\circ \text{ V rms}$$

$$P_{\phi} = 50 \text{ kW}$$

$$pf = 0.8 \text{ lagging}$$

$$Z_C = -j2 \Omega$$

Original situation per phase:

$$\begin{aligned} S_{old} &= \frac{50}{0.8} \angle \cos^{-1}(0.8) \\ &= 62.5 \angle 36.87^\circ \\ &= 50 + j37.5 \text{ kVA} \end{aligned}$$

Corrected situation:

$$P_{new} = P_{old} = 50 \text{ kW}$$

$$\begin{aligned} Q_{new} &= Q_{old} + Q_C \\ &= (37.5 \times 10^3) + Q_C \end{aligned}$$

$$Q_C = -\frac{|V_{an}|^2}{|Z_C|} = -24.2 \text{ kVAR}$$

$$Q_{new} = 13.3 \text{ kVAR}$$

$$S_{new} = 51.74 \angle 14.90^\circ \text{ kVA}$$

$$pf_{new} = \cos \theta_{new} = \cos(14.90^\circ) = 0.97 \text{ lagging}$$

Problem 10.59

A three-phase *abc*-sequence wye-connected source with $V_{an} = 220\angle 0^\circ$ V rms supplies power to a wye-connected load that consumes 150 kW of power at a pf of 0.8 lagging. Three capacitors are found that each have an impedance of $-j2.0 \Omega$, and they are connected in parallel with the previous load in a delta configuration. Determine the power factor of the combined load as seen by the source.

Suggested Solution

$$V_{an} = 220\angle 0^\circ \text{ V rms}$$

$$P_{\phi} = 50 \text{ kW}$$

$$pf = 0.8 \text{ lagging}$$

$$Z_{C\Delta} = -j2 \Omega$$

$$Z_{CY} = \frac{Z_{C\Delta}}{3} = -j\frac{2}{3} \Omega$$

Original situation per phase:

$$\begin{aligned} S_{old} &= \frac{50}{0.8} \angle \cos^{-1}(0.8) \\ &= 62.5 \angle 36.87^\circ \\ &= 50 + j37.5 \text{ kVA} \end{aligned}$$

Corrected situation:

$$P_{new} = P_{old} = 50 \text{ kW}$$

$$\begin{aligned} Q_{new} &= Q_{old} + Q_C \\ &= (37.5 \times 10^3) + Q_C \end{aligned}$$

$$Q_C = -\frac{|V_{an}|^2}{|Z_{CY}|} = -72.6 \text{ kVAR}$$

$$Q_{new} = -35.1 \text{ kVAR}$$

$$S_{new} = 61.09 \angle -35.07^\circ \text{ kVA}$$

$$pf_{new} = \cos \theta_{new} = \cos(-35.07^\circ) = 0.82 \text{ leading}$$

Problem 10.60

Find C in the network shown such that the total load has a power factor of 0.9 lagging.

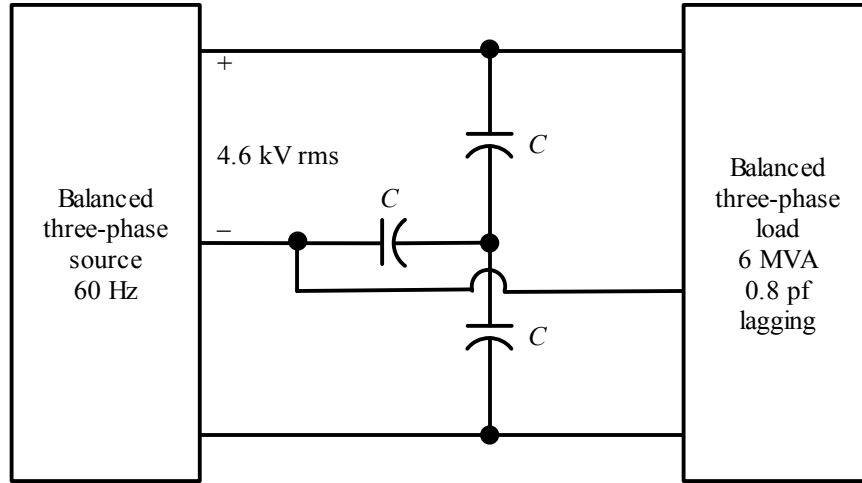

Suggested Solution

$$V_{ab} = 4.6 \text{ kV rms} \quad |S_{L3\phi}| = 6 \text{ MVA} \quad pf_{old} = 0.8 \text{ lagging}$$

$$pf_{new} = 0.9 \text{ lagging} \quad f = 60 \text{ Hz}$$

$$S_{L1\phi} = \frac{S_{L3\phi}}{3} = 2 \angle \cos^{-1} 0.8 = 1.60 + j1.20 \text{ MVA}$$

Old situation per phase:

$$S_{old} = 1.60 + j1.20 \text{ MVA}$$

New situation:

$$\begin{aligned} S_{new} &= \frac{1.60}{0.9} \angle \cos^{-1}(0.9) \\ &= 1.60 + j0.77 \text{ kVA} \\ &= P_{old} + j(Q_{old} + Q_C) \end{aligned}$$

$$Q_C = 0.77 - 1.20 = -0.43 \text{ MVAR}$$

But,

$$Q_C = -\omega C_Y V_{an}^2 = -\frac{\omega C_Y V_{ab}^2}{3}$$

$$\therefore C_Y = 161.7 \mu\text{F}$$

Problem 10.61

Find C in the network shown such that the total load has a power factor of 0.9 leading.

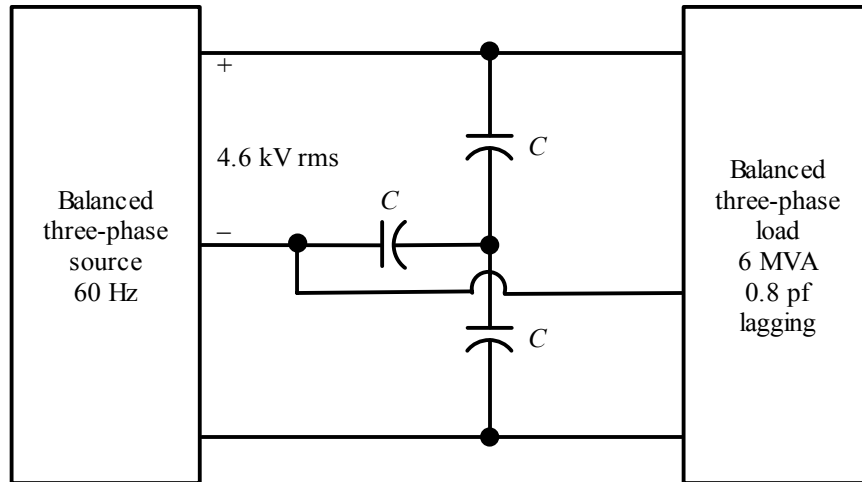

Suggested Solution

$$pf_{new} = 0.9 \text{ leading} \quad f = 60 \text{ Hz}$$

Original complex power per phase:

$$S_{old} = 2 \angle 36.87^\circ = 1.6 + j1.2 \text{ MVA}$$

Corrected complex power per phase:

$$\begin{aligned} S_{new} &= \frac{1.6}{0.9} \angle -\cos^{-1}(0.9) \\ &= 1.6 - j0.77 \text{ MVA} \end{aligned}$$

$$Q_{old} + Q_C = Q_{new} \quad \Rightarrow \quad Q_C = -0.77 - 1.20 = -1.97 \text{ MVAR}$$

But,

$$Q_C = -\omega C_Y V_{an}^2 = -\frac{\omega C_Y V_{ab}^2}{3}$$

$$\therefore C_Y = 740.9 \mu\text{F}$$

Problem 10.62

Find C in the network shown such that the total load has a power factor of 0.92 leading.

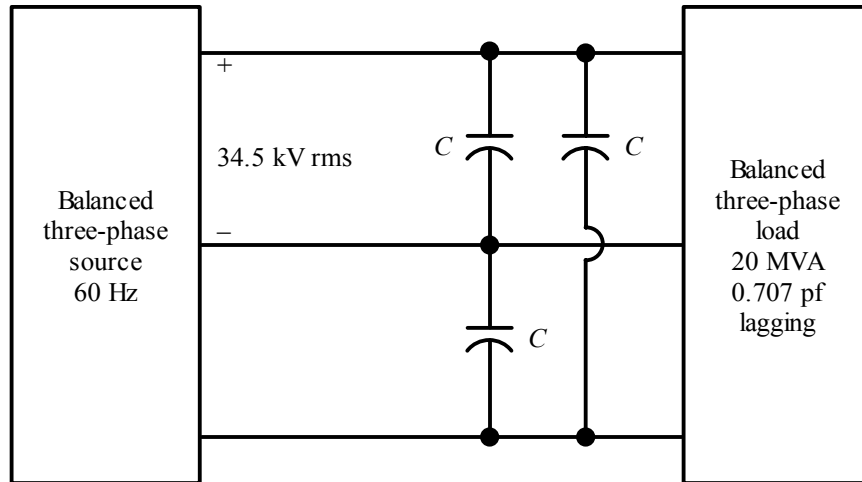

Suggested Solution

$$V_{ab} = 34.5 \text{ kV rms} \quad f = 60 \text{ Hz} \quad S_{3\phi} = 20 \text{ MVA}$$

$$pf_{old} = 0.707 \text{ lagging} \quad pf_{new} = 0.92 \text{ leading}$$

Old complex power per phase:

$$S_{old} = \frac{20}{3} \angle \cos^{-1}(0.707) = 4.71 + j4.71 \text{ MVA}$$

New complex power per phase:

$$S_{new} = \frac{4.71}{0.92} \angle -\cos^{-1}(0.92) = 4.71 - j2.01 \text{ MVA}$$

$$Q_C = -\omega C_{\Delta} V_{ab}^2 = Q_{new} - Q_{old} = -6.72 \text{ MVAR}$$

$$C_{\Delta} = 15.0 \mu\text{F}$$

Problem 10.63

Find C in the network shown such that the total load has a power factor of 0.92 lagging.

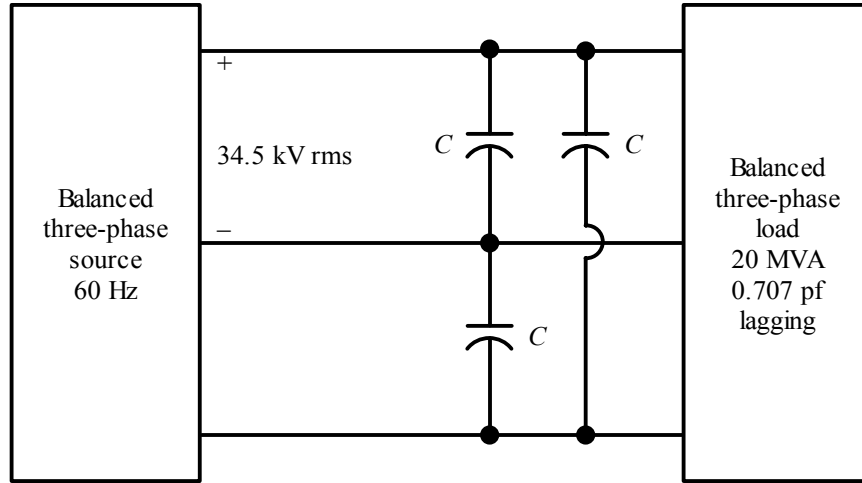

Suggested Solution

$$V_{ab} = 34.5 \text{ kV rms} \quad f = 60 \text{ Hz} \quad S_{3\phi} = 20 \text{ MVA}$$

$$pf_{old} = 0.707 \text{ lagging} \quad pf_{new} = 0.92 \text{ lagging}$$

Old complex power per phase:

$$S_{old} = \frac{20}{3} \angle \cos^{-1}(0.707) = 4.71 + j4.71 \text{ MVA}$$

New complex power per phase:

$$S_{new} = \frac{4.71}{0.92} \angle \cos^{-1}(0.92) = 4.71 + j2.01 \text{ MVA}$$

$$Q_C = -\omega C_{\Delta} V_{ab}^2 = Q_{new} - Q_{old} = -2.70 \text{ MVAR}$$

$$C_{\Delta} = 6.0 \mu\text{F}$$

Problem 10FE-1

A wye-connected load consists of a series RL impedance. Measurements indicate that the rms voltage across each element is 84.85 V. If the rms line current is 6 A, find the total complex power for the three-phase load configuration.

Suggested Solution

$$\mathbf{V}_L = 84.85 + j84.85 = 120\angle 45^\circ \text{ V}$$

$$\begin{aligned}\mathbf{S}_T &= 3 \left[(6)^2 \left(\frac{84.85}{6} \right) + j(6)^2 \left(\frac{84.85}{6} \right) \right] \\ &= 1527.3 + j1527.3 \\ &= 2160\angle 45^\circ \text{ VA}\end{aligned}$$

or

$$\mathbf{S}_T = 3(120\angle 45^\circ)(6) = 2160\angle 45^\circ \text{ VA}$$

Problem 10FE-2

A balanced three-phase delta-connected load consists of an impedance of $12 + j12 \Omega$. If the line voltage at the load is measured to be 230 V rms, find the magnitude of the line current and the total real power absorbed by the three-phase configuration.

Suggested Solution

$$|\mathbf{I}_\phi| = \left| \frac{230}{12 + j12} \right| = 13.55 \text{ A rms}$$

$$|\mathbf{I}_L| = \sqrt{3} |\mathbf{I}_\phi| = 23.47 \text{ A rms}$$

$$P_{total} = \sqrt{3} |\mathbf{V}_L| |\mathbf{I}_L| \cos 45^\circ = 6.61 \text{ kW}$$

or

$$P_{total} = 3 |\mathbf{I}_\phi|^2 R_\phi = 3(13.55)^2 (12) = 6.61 \text{ kW}$$

Problem 10FE-3

Two balanced three-phase loads are connected in parallel. One load with a phase impedance of $24 + j18 \Omega$ is connected in delta, and the other load has a phase impedance of $6 + j4 \Omega$ and is connected in wye. If the line-to-line voltage is 208 V rms, determine the line current.

Suggested Solution

Assume $208\angle 0^\circ$ V rms

For Δ :

$$\mathbf{I}_\phi = \frac{208\angle 0^\circ}{24 + j18} = 6.933\angle -36.87^\circ \text{ A rms}$$

$$\mathbf{I}_L = (\sqrt{3})(\angle -30^\circ)(6.933\angle -36.87^\circ) = 12\angle -66.87^\circ \text{ A rms}$$

For Y:

$$\mathbf{I}_L = \frac{\frac{208}{\sqrt{3}}\angle -30^\circ}{6 + j4} = 16.64\angle -63.69^\circ \text{ A rms}$$

Total line current:

$$\begin{aligned}\mathbf{I}_L &= 12\angle -66.87^\circ + 16.64\angle -63.69^\circ \\ &= 12.09 - j25.96 \\ &= 28.64\angle -65^\circ \text{ A rms}\end{aligned}$$

or

$$\text{Convert } \Delta \rightarrow Y \Rightarrow 8 + j6 \Omega$$

$$\therefore \mathbf{Z}_{total} = \frac{(6 + j4)(8 + j6)}{(6 + j4) + (8 + j6)} = \frac{24 + j68}{14 + j10} = 4.19\angle 35.06^\circ \Omega$$

Then

$$\mathbf{I}_L = \frac{\frac{208}{\sqrt{3}}\angle -30^\circ}{4.19\angle 35.06^\circ} = 28.66\angle -65.06^\circ \text{ A rms}$$

Problem 10FE-4

The total complex power at the load of a three-phase balanced system is $24\angle 30^\circ$ kVA. Find the real power per phase.

Suggested Solution

$$\begin{aligned} \mathbf{S} &= 24,000\angle 30^\circ \text{ VA} \\ &= 20,785 + j12,000 \text{ VA} \end{aligned}$$

$$P_\phi = \frac{20,785}{3} = 6.928 \text{ kW}$$

Problem 11.1

Determine the driving point impedance at the input terminals of the network shown in fig P11.1 as a function of s .

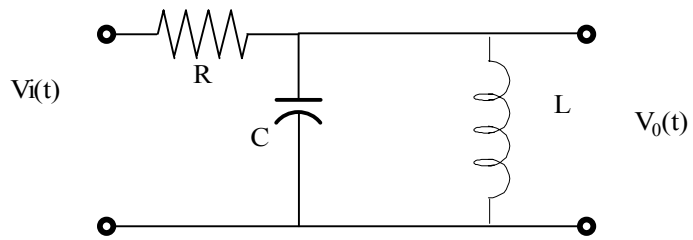

Suggested Solution

$$Z(s) = R + \left(\frac{1}{sC} \parallel sL \right) = R + \frac{\frac{L}{C}}{\frac{1}{sC} + sL} = R + \frac{sL}{1 + s^2LC} = \frac{s^2LCR + sL + R}{s^2LC + 1}$$

Problem 11.2

Determine the voltage transfer function $V_o(s)/V_c(s)$ as a function of s for the network shown in fig p11.1.

Suggested Solution

$$\frac{V_o}{V_i}(s) = \frac{\left(\frac{1}{sC} \parallel sL\right)}{R + \left(\frac{1}{sC} \parallel sL\right)} = \frac{\frac{\frac{L}{C}}{\frac{1}{sC} + sL}}{R + \frac{\frac{L}{C}}{\frac{1}{sC} + sL}} = \frac{\frac{L}{C}}{\frac{R}{sC} + R sL + \frac{L}{C}} = \frac{sL}{s^2 LCR + sL + R}$$

$$\frac{sL}{s^2 LCR + sL + R}$$

Problem 11.3

Determine the voltage transfer function $V_o(s)/V_i(s)$ as a function of s for the network shown in fig p11.3.

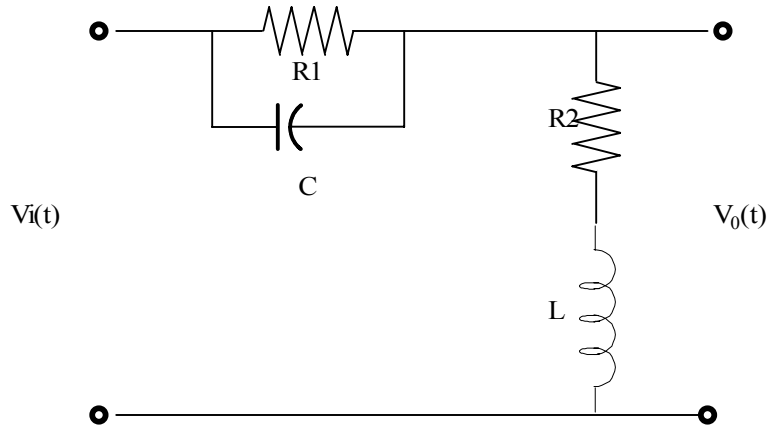

Suggested Solution

$$\begin{aligned} \frac{V_o}{V_i}(s) &= \frac{(R_2 + sL)}{(R_2 + sL) + \frac{R_1}{sC}} = \frac{(R_2 + sL)}{(R_2 + sL) + \frac{R_1}{sCR_1 + 1}} \\ &= \frac{(R_2 + sL)(sCR_1 + 1)}{R_2 + sCR_1R_2 + s^2LCR_1 + sL + R_1} = \frac{(R_2 + sL)(sCR_1 + 1)}{s^2LCR_1 + s(L + CR_1R_2) + R_1 + R_2} \\ &= \frac{(s + \frac{R_2}{L})(s + \frac{1}{CR_1})}{s^2 + \left[\frac{1}{R_1C} + \frac{R_2}{L} \right] s + \frac{R_1 + R_2}{LCR_1}} \end{aligned}$$

$$\frac{(s + \frac{R_2}{L})(s + \frac{1}{CR_1})}{s^2 + \left[\frac{1}{R_1C} + \frac{R_2}{L} \right] s + \frac{R_1 + R_2}{LCR_1}}$$

Problem 11.4

Find the transfer impedance $V_o(s)/I_s(s)$ for the network shown in fig 11.4.

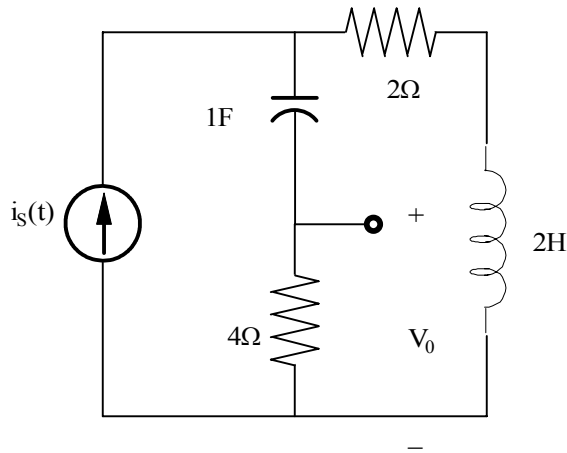

Suggested Solution

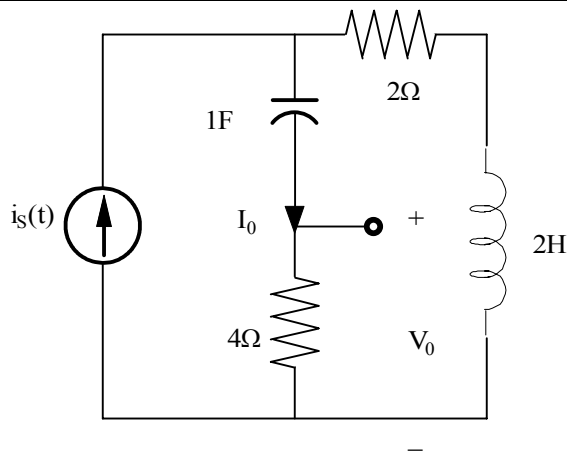

$$I_o = I_s \left[\frac{2S+2}{2S+2+4+\frac{1}{S}} \right]$$

$$\frac{I_o}{I_s} = \frac{2S^2+2S}{2S^2+6S+1}, V_o = 4I_o, \text{SO } \frac{V_o}{I_s} = \frac{8S(S+1)}{2S^2+6S+1}$$

$$\frac{8S(S+1)}{2S^2+6S+1}$$

Problem 11.5

Find the driving point impedance at the input terminal of the circuit in fig 11.5.

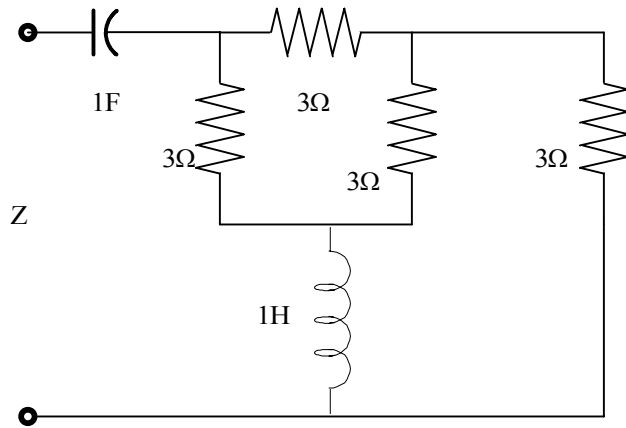

Suggested Solution

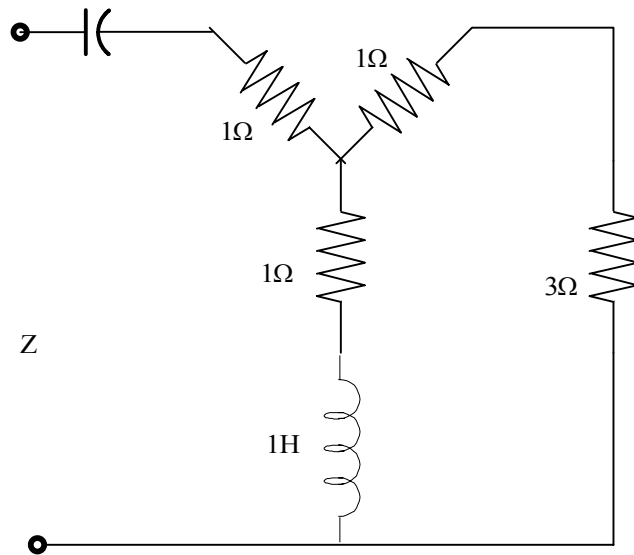

$$Z_i(s) = \frac{4(1+S)}{5+S} + 1 + \frac{1}{S} = \frac{5(S+1)^2}{S(S+5)}$$

Problem 11.6

Draw the bode plot for the network function.

Suggested Solution

$$H(j\omega) = \frac{j\omega 5 + 1}{j\omega 20 + 1}$$

Problem 11.7

Draw the bode plot for the network function.

$$H(j\omega) = \frac{j\omega^2 + 1}{j\omega + 1}$$

Suggested Solution

$$H(j\omega) = \frac{j\omega^2 + 1}{j\omega + 1}$$

Problem 11.8

Draw the bode plot for the network function.

$$H(j\omega) = \frac{10(10j\omega + 1)}{(100j\omega + 1)(j\omega + 1)}$$

Suggested Solution

$$H(j\omega) = \frac{10(10j\omega + 1)}{(100j\omega + 1)(j\omega + 1)}$$

Zeros: 0.1 r/s

Poles: 0.01 & 1 r/s

$H(j0) = 10 = 20\text{dB}$

Problem 11.9

Draw the bode plot for the network function.

$$H(j\omega) = \frac{j\omega}{(j\omega + 1)(0.1j\omega + 1)}$$

Suggested Solution

$$H(j\omega) = \frac{j\omega}{(j\omega + 1)(0.1j\omega + 1)}$$

Zero :dc

Poles: 1 & 10 r/s

Problem 11.10

Draw the bode plot for the network function.

$$H(j\omega) = \frac{10j\omega + 1}{(j\omega)(0.1j\omega + 1)}$$

Suggested Solution

$$H(j\omega) = \frac{10j\omega + 1}{(j\omega)(0.1j\omega + 1)}$$

zeros : 0.1 r/s

poles : dc & 10 r/s

Problem 11.11

Sketch the magnitude characteristic of the bode plot for the transfer function.

$$H(j\omega) = \frac{10}{(j\omega)(0.1j\omega + 1)}$$

Suggested Solution

Problem 11.12

Sketch the magnitude characteristic of the bode plot for the transfer function.

$$H(j\omega) = \frac{20(0.1j\omega + 1)}{(j\omega)(0.1j\omega + 1)(0.01j\omega + 1)}$$

Suggested Solution

Problem 11.13

Sketch the magnitude characteristic of the bode plot for the transfer function.

$$H(j\omega) = \frac{100(j\omega)}{(j\omega + 1)(j\omega + 10)(j\omega + 50)}$$

Suggested Solution

$$H(j\omega) = \frac{\frac{1}{S}(j\omega)}{(j\omega + 1)\left(\frac{j\omega}{10} + 1\right)\left(\frac{j\omega}{50} + 1\right)}$$

Problem 11.14

Draw the bode plot for the network function.

$$H(j\omega) = \frac{16}{(j\omega)^2(j\omega^2 + 1)}$$

Suggested Solution

$$H(j\omega) = \frac{16}{(j\omega)^2(j\omega^2 + 1)}$$

zeros: none

poles: [2@dc](#), 10 r/s

also: 16=24.1dB

Problem 11.15

Sketch the magnitude characteristic of the bode plot for the transfer function.

$$H(j\omega) = \frac{640(j\omega + 1)(0.01j\omega + 1)}{(j\omega)^2(j\omega + 10)}$$

Suggested Solution

$$H(j\omega) = \frac{640(j\omega + 1)(0.01j\omega + 1)}{(j\omega)^2(j\omega + 10)} = \frac{64(j\omega + 1)(0.01j\omega + 1)}{(j\omega)^2(0.1j\omega + 1)}$$

poles: 2@dc, 10 r/s

zeroes at : 1 & 100 r/s

also: 64=36.1dB

Problem 11.16

Sketch the magnitude characteristic of the bode plot for the transfer function.

$$H(j\omega) = \frac{10^5 (5j\omega + 1)^2}{(j\omega)^2 (j\omega + 10)(j\omega + 100)^2}$$

Suggested Solution

$$H(j\omega) = \frac{10^5 (5j\omega + 1)^2}{(j\omega)^2 (j\omega + 10)(j\omega + 100)^2}$$

$$H(j\omega) = \frac{(5j\omega + 1)^2}{(j\omega)^2 (0.1j\omega + 1)(0.01j\omega + 1)^2}$$

poles: [2@dc](#), 10 r/s & 2@ 100r/s

zeroe at : 2@ 0.2r/s

also: 64=36.1dB

Problem 11.17

Sketch the magnitude characteristic of the bode plot for the transfer function.

$$G(j\omega) = \frac{10j\omega}{(j\omega + 1)(j\omega + 10)^2}$$

Suggested Solution

$$G(j\omega) = \frac{10j\omega}{(j\omega + 1)(j\omega + 10)^2} = \frac{0.1j\omega}{(j\omega + 1)(0.1j\omega + 1)^2}$$

poles at : 1 and 2@ 10 r/s

zeros at : dc

also : 0.1 = - 20 dB

Problem 11.18

Sketch the magnitude characteristic of the bode plot for the transfer function.

$$H(j\omega) = \frac{100(j\omega)^2}{(j\omega+1)(j\omega+10)^2(j\omega+50)}$$

Suggested Solution

$$H(j\omega) = \frac{100(j\omega)^2}{(j\omega+1)(j\omega+10)^2(j\omega+50)}$$

$$H(j\omega) = \frac{(1/50)(j\omega)^2}{(j\omega+1)(0.1j\omega+1)^2(0.02j\omega+1)}$$

poles : 1, 50 and 2@ 10 r/s

zeros: 2 @ dc

also: $1/50 = -34$ dB

Problem 11.19

Sketch the magnitude characteristic of the bode plot for the transfer function.

$$G(j\omega) = \frac{-\omega^2 10^4}{(j\omega + 1)^2 (j\omega + 10)(j\omega + 100)^2}$$

Suggested Solution

$$G(j\omega) = \frac{-\omega^2 10^4}{(j\omega + 1)^2 (j\omega + 10)(j\omega + 100)^2} = \frac{-(1/10)\omega^2}{(j\omega + 1)^2 (0.1j\omega + 1)(0.01j\omega + 1)^2}$$

poles : 2@ 1 r/s, 1@ 10 r/s, 2@ 100 r/s

zeros: 2 @ dc

also: 0.1 = -20 dB

Problem 11.20

Sketch the magnitude characteristic of the bode plot for the transfer function.

$$G(j\omega) = \frac{64(j\omega + 1)^2}{-j\omega^3(0.1j\omega + 1)}$$

Suggested Solution

$$G(j\omega) = \frac{64(j\omega + 1)^2}{-j\omega^3(0.1j\omega + 1)}$$

poles : 3@dc, 1@ 10 r/s

zeros: 2 @ 1 r/s

also: 64 = 36.1 dB

Problem 11.21

Sketch the magnitude characteristic of the bode plot for the transfer function.

$$G(j\omega) = \frac{-\omega^2}{(j\omega + 1)^3}$$

Suggested Solution

$$G(j\omega) = \frac{-\omega^2}{(j\omega + 1)^3}$$

poles: 3 @ 1 r/s

zeros: 2 @ dc

Problem 11.22

Draw the Bode plot for the network function.

$$H(j\omega) = \frac{72(j\omega + 2)}{j\omega \left[(j\omega)^2 + 2.4j\omega + 144 \right]}$$

Suggested Solution

$$H(j\omega) = \frac{72(j\omega + 2)}{j\omega \left[(j\omega)^2 + 2.4j\omega + 144 \right]}$$

$$H(j\omega) = \frac{(0.5j\omega + 1)}{j\omega \left[(j\omega/12)^2 + (j\omega/60) + 1 \right]}$$

zeros : 1 @ 2 r/s

simple pole : 1 @ dc

complex poles $T = (1/12)s$ & $2\tau\xi = 1/60$

so $\omega_0 = 12$ r/s $\xi = 0.1$

Problem 11.23

Sketch the magnitude characteristics of the Bode plot for the transfer function.

$$G(j\omega) = \frac{10^4 (j\omega + 1) [-\omega^2 + 6j\omega + 225]}{j\omega (j\omega + 450) (j\omega + 50)^2}$$

Suggested Solution

$$G(j\omega) = \frac{10^4 (j\omega + 1) [-\omega^2 + 6j\omega + 225]}{j\omega (j\omega + 450) (j\omega + 50)^2}$$

$$G(j\omega) = \frac{2(j\omega + 1) [(j\omega/15)^2 + (2/75)j\omega + 1]}{(j\omega)(j\omega/450 + 1)(0.02j\omega + 1)^2}$$

poles : dc 2@ 50 and 450 r/s

simple pole : 1 r/s

complex poles $T = (1/15)s$ $2\tau\xi = 2/75$

so $\omega_0 = 15$ r/s $\xi = 0.2$

also: 2=6dB

Problem 11.24

Sketch the magnitude characteristic of the Bode plot for the transfer function.

$$H(j\omega) = \frac{81(j\omega + 0.1)}{j\omega[-\omega^2 + 3.6j\omega + 81]}$$

Suggested Solution

$$H(j\omega) = \frac{0.1\left(\frac{j\omega}{0.1} + 1\right)}{j\omega\left[\frac{-(\omega)^2}{81} + \frac{3.6}{81}j\omega + 1\right]}$$

Problem 11.25

Sketch the magnitude characteristic of the bode plot for the transfer function.

$$H(j\omega) = \frac{6.4(j\omega)}{(j\omega + 1)(1 - \omega^2 + 8j\omega + 64)}$$

Suggested Solution

$$H(j\omega) = \frac{0.1(j\omega)}{(j\omega + 1)\left(-\frac{\omega^2}{64} + \frac{1}{8}j\omega + 1\right)}$$

POLES : 0.5r/s & [2@10r/s](#)

ZEROS: 0.1 r/s

Problem 11.26

Determine $H(j\omega)$ if the amplitude characteristic for $H(j\omega)$ is shown in fig 26.

Suggested Solution

$$|H(j\omega)| = -40dB = 0.01$$

$$H(j\omega) = \frac{10j\omega + 1}{100(2j\omega + 1)(0.1j\omega + 1)^2}$$

Poles: $10r/s$ & $2@ 80r/s$

Zeros: $1&120r/s$

Problem 11.27

Find $H(j\omega)$ if its magnitude characteristic is shown in fig 27.

Suggested Solution

$$|H(j\omega)| = 40\text{dB} = 100$$

$$H(j\omega) = \frac{100(j\omega + 1)\left(\frac{j\omega}{120} + 1\right)}{(0.1j\omega + 1)\left(\frac{j\omega}{80} + 1\right)^2}$$

poles: 10 r/s & 2 @ 80 r/s

zeroes : 0.1 r/s

$$H(j0) = 40\text{ dB} = 100$$

Problem 11.28

Find $H(j\omega)$ if its magnitude characteristic is shown in fig 28.

Suggested Solution

There is a zero at $\omega = 10$ rad/s, A pole at $\omega = 0$ and A double pole at $\omega = 20$ rad/s.
Since the initial slope of -20 dB /dec cuts the odB line at $\omega = 0$, the gain is 10.

\therefore

$$H(j\omega) = \frac{10\left(\frac{j\omega}{10} + 1\right)}{j\omega\left(\frac{j\omega}{20} + 1\right)^2}$$

Problem 11.29

Find $H(j\omega)$ if its amplitude characteristic is shown in fig 29.

Suggested Solution

The initial slope of -20dB/dec will cut the 0dB line at $\omega=40\text{r/s}$. Therefore the gain is 40. The zeros are at $\omega=50\text{r/s}$ and $\omega=1000\text{r/s}$. The pole are at $\omega=0$ and there is a double pole at $\omega=400$.

$$H(j\omega) = \frac{40\left(\frac{j\omega}{50} + 1\right)\left(\frac{j\omega}{1000} + 1\right)}{j\omega\left(\frac{j\omega}{100} + 1\right)^2}$$

Problem 11.30

Find $H(j\omega)$ if its magnitude characteristics is shown in fig 11.30.

Suggested Solution

Poles: 0.8, 100 \$ 2@700 r/s

Zeros: dc, 12 r/s

$$|H(j0.05)| = -20dB = 0.1$$

$$H(j\omega) = \frac{K(j\omega)\left(\frac{j\omega}{12} + 1\right)}{(1.25j\omega + 1)\left(\frac{j\omega}{100} + 1\right)\left(\frac{j\omega}{100} + 1\right)^2}$$

$$|H(j0.05)| = \frac{K(0.05)(1)}{(1)} = 0.1 \Rightarrow K = 2$$

$$H(j\omega) = \frac{2(j\omega)\left(\frac{j\omega}{12} + 1\right)}{(1.25j\omega + 1)\left(\frac{j\omega}{100} + 1\right)\left(\frac{j\omega}{100} + 1\right)^2}$$

Problem 11.31

Find $H(j\omega)$ if its amplitude characteristics is shown in fig 11.31.

Suggested Solution

The initial slope indicates that the gain is 1, there are zeroes at $\omega=0$ and $\omega=30$. The poles are at $\omega=1$, $\omega=100$ and a double pole $\omega=8/5$

$$H(j\omega) = \frac{1(j\omega)\left(\frac{j\omega}{30} + 1\right)}{(j\omega + 1)\left(\frac{j\omega}{100} + 1\right)\left(\frac{j\omega}{8} + 1\right)^2}$$

Problem 11.32

Given the magnitude characteristics in fig 11.32, find $G(j\omega)$.

Suggested Solution

Poles : 2@ dc, $\frac{1}{3}$ @200r/s

Zeros: 1.5 & 10 r/s

$$|H(j0.02)| = 80dB = 10^4$$

$$H(j\omega) = \frac{K(0.1j\omega+1)\left(\frac{2j\omega}{3}+1\right)}{(j\omega)^2\left(\frac{j\omega}{80}+1\right)\left(\frac{j\omega}{200}+1\right)}$$

$$|H(j0.02)| = 10^4 \Rightarrow k = 400$$

$$H(j\omega) = \frac{400(0.1j\omega+1)\left(\frac{2j\omega}{3}+1\right)}{(j\omega)^2\left(\frac{j\omega}{80}+1\right)\left(\frac{j\omega}{200}+1\right)}$$

Problem 11.33

Find $G(j\omega)$ if the amplitude characteristic for this function is shown in fig 11.33.

Suggested Solution

Zeros: $2@100$ r/s

Simple poles: dc $\$ 900$ r/s

Complex poles : $\tau=1/20$ s $\$ \zeta=0.1$

So $\omega_0=20$ r/s

$\$ 2\xi\zeta=0.01$

Also,

$$H(j0.8) = 20dB = 10$$

$$H(j\omega) = \frac{k(0.1j\omega+1)^2}{(j\omega)\left(\frac{j\omega}{900}+1\right)\left(\left(\frac{j\omega}{20}\right)^2 + \frac{j\omega}{100}+1\right)}$$

$$H(j0.8) = 10 \Rightarrow K = 8$$

$$H(j\omega) = \frac{0.8(0.1j\omega+1)^2}{(j\omega)\left(\frac{j\omega}{900}+1\right)\left(\left(\frac{j\omega}{20}\right)^2 + \frac{j\omega}{100}+1\right)}$$

Problem 11.34

A series of RLC circuit resonates at 2000 rad/s. If $C = 20\mu\text{F}$ and it is known that the impedance at resonance is 2.4 ohm, compute the value of L, the Q of the circuit and the bandwidth.

Suggested Solution

$$W_o = 2000 \frac{r}{s} = \frac{1}{\sqrt{LC}} \Rightarrow L = 12.5mH$$

$$THEN \quad Q = \frac{W_o L}{R} = 10.42$$

$$BW = \frac{W_o}{Q} = \frac{2000}{10.42} = 192 \frac{r}{s}$$

Problem 11.35

A series resonant circuit has a Q of 120 and a resonant frequency of 60,000 rad/s. Determine the half-power frequencies and the bandwidth of the circuit.

Suggested Solution

$$BW = \frac{W_o}{Q} = \frac{60K}{120} = 500 \frac{r}{s}$$

$$W_{LO,HI} = W_o \left(\sqrt{\left(\frac{1}{2Q}\right)^2 + 1} \pm \frac{1}{2Q} \right)$$

$$W_{HI} = 60.25Kr/s \quad \text{ALSO } BW = W_{HI} - W_{LO}$$

$$W_{LO} = 59.75Kr/s$$

Problem 11.36

Given the series RLC circuit in fig 11.36 if $R=10\text{ohm}$, find the values of L and C such that the network will have a resonant frequency of 100 kHz and a bandwidth of 1kHz .

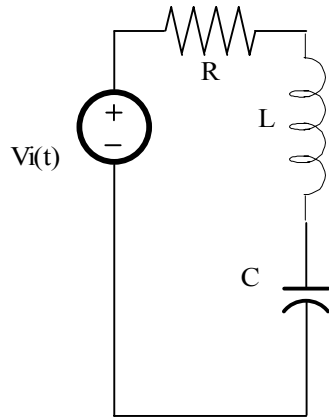

Suggested Solution

$$W_o = \frac{1}{\sqrt{LC}} = 200\pi \frac{Kr}{s}$$

$$Q = \frac{W_o L}{R} = \frac{(100K)(2\pi)L}{10} = 100 \Rightarrow L = 1.59mH$$

$$W_o = \frac{1}{\sqrt{LC}} \Rightarrow C = 1.59nF$$

$$C = 1.59nF$$

Problem 11.37

Given the network in fig 11.37, find ω_o , Q , W_{\max} and $V_o(\max)$.

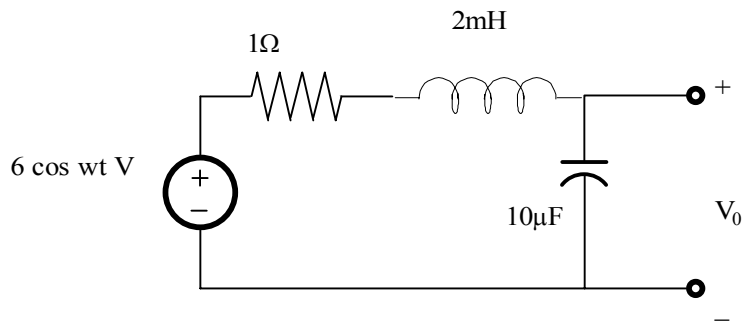

Suggested Solution

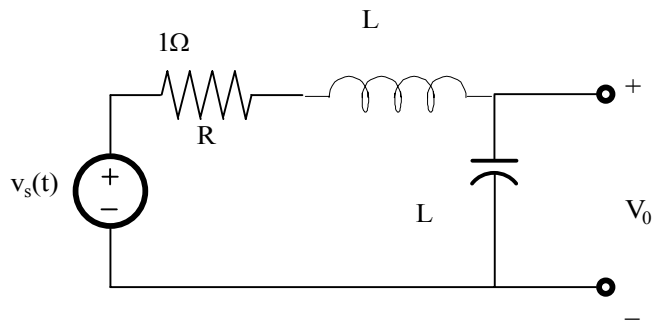

$$W_o = \frac{1}{\sqrt{LC}} = 7071 \frac{r}{s} \quad Q = \frac{W_o L}{R} = 14.14$$

$$W_{\max} = W_o \sqrt{1 - \frac{1}{2Q^2}} = 7062 \frac{r}{s}$$

$$|V_o|_{\max} = \frac{Q|V_s|}{\sqrt{1 - \frac{1}{4Q^2}}} = 84.89V$$

$$W_o = 7071 \frac{r}{s} \quad Q = 14.14 \quad W_{\max} = 7062 \frac{r}{s} \quad |V_o|_{\max} = 84.89V$$

Problem 11.38

Repeat the problem 11.37 if the value of R is changed to 0.1ohm.

Suggested Solution

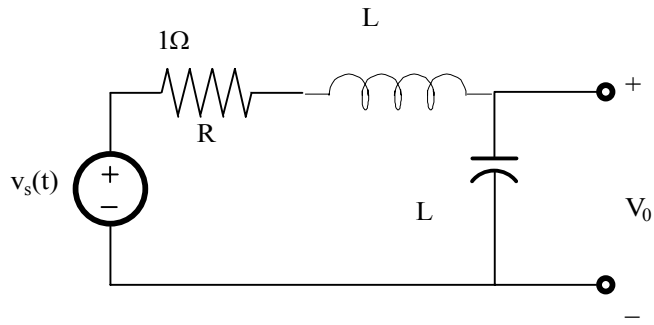

$$W_o = \frac{1}{\sqrt{LC}}$$

$$Q = \frac{W_o L}{R}$$

$$W_{\max} = W_o \sqrt{\left(1 - \frac{1}{2Q^2}\right)}$$

$$W_o = 7071 \frac{r}{s} \quad Q = 141 \quad W_{\max} = 7071 \frac{r}{s} \quad |V_o|_{\max} = 846V$$

Problem 11.39

A series RLC circuit is driven by a signal generator. The resonant frequency of the network is known to be 1600 rad/s and at that frequency the impedance seen by the signal generator is 5ohm. If $C=20\mu\text{F}$, find L,Q and the bandwidth.

Suggested Solution

$$W_o = \frac{1}{\sqrt{LC}} \Rightarrow L = 19.5mH$$

$$BW = R / L = 256r / s$$

$$Q = \frac{W_o}{BW} = 6.25$$

$$L = 19.5mH$$

$$BW = 256r / s$$

$$Q = 6.25$$

Problem 11.40

A variable frequency voltage source drives the network in fig 11.40. Determine the resonant frequency, Q , BW and the average power dissipated by the network at resonance.

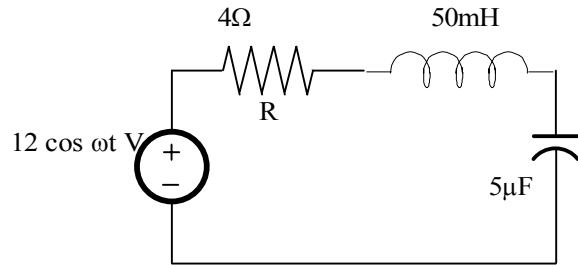

Suggested Solution

$$\omega_o = \frac{1}{\sqrt{LC}} \Rightarrow 2 \frac{kr}{s}$$

$$Q = \frac{\omega_o L}{R} = 25$$

$$BW = \frac{\omega_o}{Q} = 80r / s$$

$$P = 18W$$

Problem 11.41

In the network in fig 11.41 the inductor value is 30mH, and the circuit is driven by a variable frequency source. If the magnitude of the current at resonance is 12A, $\omega_0=1000\text{rad/s}$ and $L=10\text{mH}$, find C, Q and the bandwidth of the circuit.

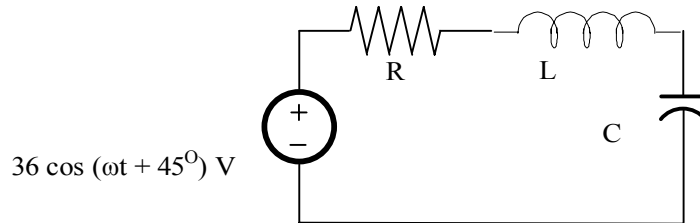

Suggested Solution

$$I_o = \frac{36}{R}$$

$$I_o = R = 3\Omega$$

$$\omega_o = \frac{1}{\sqrt{LC}} \Rightarrow 1 \frac{\text{kr}}{\text{s}} \Rightarrow C = 10\text{nF}$$

$$Q = \frac{\omega_o L}{R} = 3.33$$

$$BW = \frac{\omega_o}{Q} = 300\text{r/s}$$

Problem 11.42

Given the network in fig 11.42, find $V_o(\max)$.

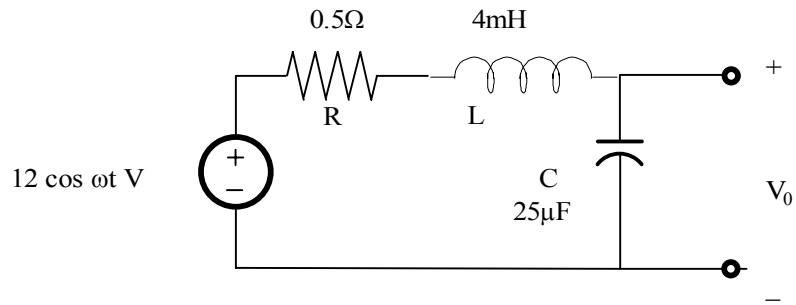

Suggested Solution

$$W_o = \frac{1}{\sqrt{LC}} \Rightarrow 3162 \frac{kr}{s}$$

$$BW = \frac{W_o}{Q} = 25.98$$

$$|V_o|_{\max} = \frac{Q|V_s|}{\sqrt{1 - \frac{1}{4Q^2}}} = 305.1V$$

Problem 11.43

A parallel RLC resonant circuit with a resonant frequency of 20,000rad/s has admittance at resonance of 1ms. If the capacitance of the network is 5 μ F, find the values of R and L.

Suggested Solution

$$R = \frac{1}{0.001} = 1K\Omega$$

$$L = \frac{1}{\omega_o^2 C} = 500\mu H$$

Problem 11.44

A parallel RLC resonant circuit with a resistance of 200ohm. If it is known that the bandwidth is 80rad/s, find the values of the parameters L and C.

Suggested Solution

$$BW = \frac{1}{RC} \Rightarrow 80 = \frac{1}{200C} \Rightarrow C = 62.5\mu F$$

$$W_{HE} = B_W + W_{LO} = 80r / s$$

$$W_o = \frac{1}{\sqrt{LC}} \Rightarrow L = 22.73mH$$

$$L = 22.73mH$$

Problem 11.45

A parallel RLC circuit, which is driven by a variable frequency 2-a current source, has the following values: $R=1\text{Kohm}$, $L=100\text{mH}$, and $C=10\mu\text{F}$. Find the bandwidth of the network, the half-power frequencies, and the voltage across the network at the half-power frequencies.

Suggested Solution

$$BW = \frac{1}{RC} \Rightarrow 100r/s \quad W_o = \frac{1}{\sqrt{LC}} \Rightarrow 1kr/s$$

$$W_o^2 = W_{HI}W_{LO} \quad \text{and} \quad W_{HI} - W_{LO} = BW$$

$$W_{LO} = \frac{W_o^2}{W_{HI}}$$

$$W_{HI}^2 - BWW_{HI} - W_o^2 = 0$$

$$W_{HI} = \frac{BW + \sqrt{BW^2 + 4W_o^2}}{2} \Rightarrow 1051.25r/s$$

$$W_{LO} = 951.25r/s$$

AT RESONANCE $|V_o| = 2KV$ AND $\frac{1}{2}$ POWER FREQUENCIES

$$|V_o| = \frac{2KV}{\sqrt{2}} = 1.41KV$$

Problem 11.46

A parallel RLC circuit, which is driven by a variable-frequency 10-A source, has the following parameters: $R=500\text{ohm}$, $L=0.5\text{ mH}$, and $C=20\mu\text{F}$. Find the resonant frequency, the BW, and the average power dissipated at the half-power frequencies.

Suggested Solution

$$W_o = \frac{1}{\sqrt{LC}} \Rightarrow 10 \frac{\text{kr}}{\text{s}} \quad BW = \frac{1}{RC} \Rightarrow 100 \text{r/s} \quad Q = \frac{W_o}{BW} = 100$$

$$W = W_o$$

$$P = 25 \text{KW}$$

$$P_{LC} = P_{HI} = 12.5 \text{KW}$$

Problem 11.47

Consider the network in fig 11.47. if $R=2\text{Kohm}$, $L=20\text{mH}$, $C=50\mu\text{F}$, and $R_s=\text{infinity}$, determine the resonant frequency ω_o , the Q of the network, and the bandwidth of the network. What impact does an R_s of 10Kohm have on the quantities determined.

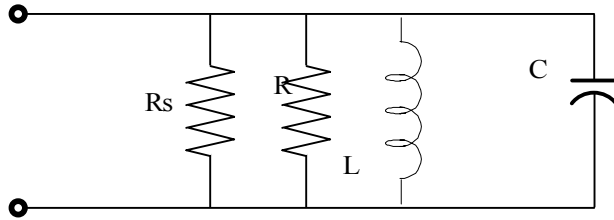

Suggested Solution

$$\omega_o = \frac{1}{\sqrt{LC}} = 1000 \frac{r}{s} \quad BW = \frac{1}{RC} \Rightarrow 10r/s \quad Q = \frac{\omega_o}{BW} = 100$$

$$R_s = 10\text{K}\Omega$$

$$R_s \parallel R = 1.67\text{K}\Omega$$

$$BW = 12r/s$$

$$Q = 83.3$$

Problem 11.48

The source in the network in fig 11.48 is $i(t) = \cos 1000t + \cos 1500t$ A. $R=200\Omega$ and $C=500\mu\text{F}$. If $\omega_0=1000\text{rad/s}$, find L , Q , and the BW. Compute the o/p voltage $V_o(t)$ and discuss the magnitude of the output voltage at the two input frequencies.

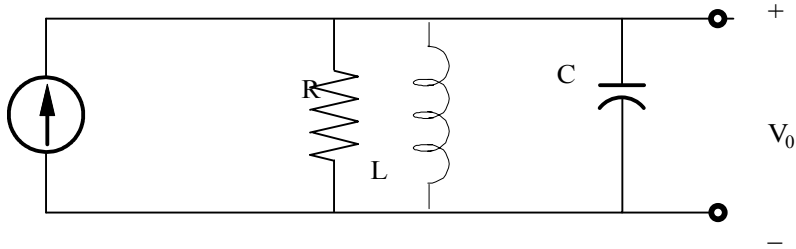

Suggested Solution

$$L = \frac{1}{\omega_0^2 C} = 2\text{mH} \quad BW = \frac{1}{RC} = 10\text{r/s} \quad Q = \frac{\omega_0 C}{BW} = 100$$

$$Z_{EQ} = R \parallel \frac{L/C}{j(\omega L - \frac{1}{\omega C})}$$

$$|Z_{EQ}| = \frac{\frac{RL}{C}}{\sqrt{\left(\frac{L}{C}\right)^2 + \left(\omega CR - \frac{R}{\omega C}\right)^2}}$$

$$Z_{EQ} = 2.4 \angle -89.3^\circ \Omega$$

$$|Z_{EQ}| = 2.4$$

$$\therefore |V_{O2}| = 2.4$$

Problem 11.49

Determine the parameters of a parallel resonant circuit which has the following properties: $\omega_o = 2\text{Mrad/sec}$, $BW = 20\text{krad/sec}$, and an impedance of 2000ohm .

Suggested Solution

$$\omega_o = \frac{1}{\sqrt{LC}} \Rightarrow C = 25\text{nF}$$

$$BW = \frac{1}{RC} \Rightarrow L = 10\mu\text{H}$$

Problem 11.50

Determine the value of C in the network shown in fig 11.50 in order for the circuit to be in resonance.

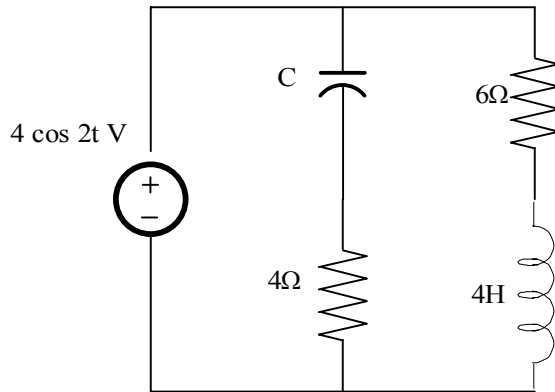

Suggested Solution

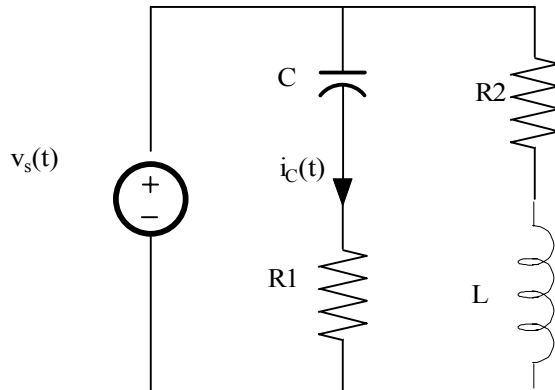

AT RESONANCE $V_s(t)$ AND $I_s(t)$ ARE IN PHASE.
SO, THE IMPEDANCE SEEN BY THE SOURCE, Z_s , IS PURELY RESISTIVE.

$$Z_s = \left(R_1 + \frac{1}{j\omega C} \right) \parallel \left(R_2 + \frac{1}{j\omega L} \right) = R_{EQ} + j0$$

$$Z_s = \left(4 + \frac{1}{j2C} \right) \parallel (6 + j8)$$

$$Z_s = \frac{24 + \frac{4}{C} + j(32 - \frac{3}{C})}{10 + j(8 - \frac{1}{2C})} = \frac{N(j\omega)}{D(j\omega)} = R_{eq}$$

IF Z_s IS RESISTIVE, THEN THE PHASE ANGLES OF $N(j\omega)$ AND $D(j\omega)$ MUST BE EQUAL.

$$\frac{32 - 3/C}{24 + 4/C} \Rightarrow 64C^2 - 25C + 1 = 0 \Rightarrow C = 45.2mF, 345.4mF$$

Problem 11.51

Determine the equation for the nonzero resonant frequency of the impedance shown in fig 11.51.

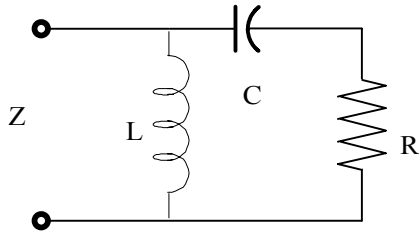

Suggested Solution

$$Z = j\omega L \parallel \left(R + \frac{1}{j\omega C} \right) = \frac{j\omega LR + L/C}{R + j(\omega L - 1/\omega C)} = \frac{N \angle \theta_N}{D \angle \theta_D}$$

FOR RESONANCE, $Z = \text{Req} + j0$, OR, $\theta_N = \theta_D$

IF $\theta_N = \theta_D$,

$$\frac{\omega_o LR}{L/C} = \frac{\omega_o - 1/\omega_o C}{R} \Rightarrow \frac{1}{\omega_o CR}$$

$$\omega_o^2 = \frac{1}{RC\left(\frac{L}{R} - RC\right)} \Rightarrow \omega_o = \sqrt{\frac{1}{LC - (RC)^2}} \text{ r/s}$$

Problem 11.52

Determine the new parameters of the network shown in fig 11.52 if $Z_{new} = 10000 Z_{old}$.

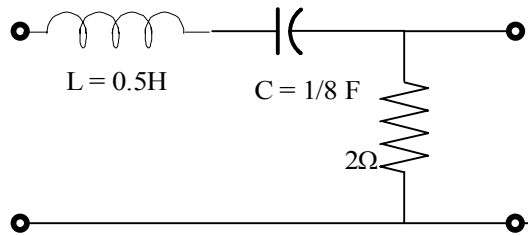

Suggested Solution

$$L = 0.5H$$

$$C = 1/8F$$

$$R = 2\Omega$$

$$Z_{NEW} = 10000Z_{OLD}$$

$$KM = 10000$$

Problem 11.53

Determine the new parameters of the network shown in fig 11.52 if $W_{\text{new}} = 10000 W_{\text{old}}$.

Suggested Solution

$$L = 0.5H$$

$$C = 1/8F$$

$$R = 2\Omega$$

$$W_{\text{NEW}} = 10000W_{\text{OLD}}$$

$$KF = 10000$$

Problem 11.54

Given the network in fig 11.54 sketch the magnitude characteristic of the transfer function.

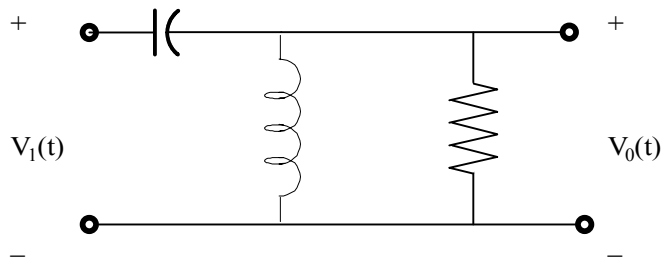

Suggested Solution

$$Z_{EQ} = j\omega L \parallel (R) = \frac{j\omega L}{1 + j\omega L / R}$$

$$G_V(j\omega) = \frac{V_0}{V_1} = \frac{Z_{EQ}}{Z_{EQ} + j\omega L / C} = \frac{j\omega L}{j\omega L + \frac{1}{j\omega C} [j\omega L / R]}$$

$$G_V(j\omega) = \frac{(j\omega)^2}{(j\omega)^2 + 10j\omega + 100}$$

FIND FORM,
$$G_V(j\omega) = \frac{0.01(j\omega)^2}{\left(\frac{j\omega}{10}\right)^2 + \frac{j\omega}{10} + 1}$$

NETWORK IS A HIGHPASS FILTER.

Problem 11.55

Given the network in fig 11.55, sketch the magnitude characteristic of the transfer function.

$$G_V(j\omega) = \frac{V_o}{V_i}(j\omega)$$

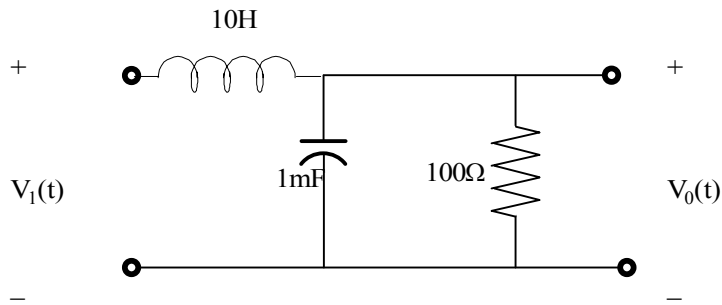

Suggested Solution

$$\text{LET } Z_{EQ} = (R) \parallel j\omega L = \frac{R}{1 + j\omega RC}$$

$$\frac{V_o}{V_i} = \frac{Z_{EQ}}{Z_{EQ} + j\omega L} = \frac{R}{R + j\omega L(1 + j\omega RC)}$$

$$\frac{V_o}{V_i} = \frac{1}{(j\omega)^2 LC + \frac{j\omega L}{R} + 1}$$

$$\frac{V_o}{V_i} = \frac{100}{(j\omega)^2 + j\omega(10) + 1}$$

$$\frac{V_o}{V_i} = \frac{1}{\left(\frac{j\omega}{10}\right)^2 + \frac{j\omega}{10} + 1}$$

NETWORK IS A LOW-PASS FILTER.

Problem 11.56

Determine what type of filter the network shown in fig 11.56 represents by determining the voltage transfer function.

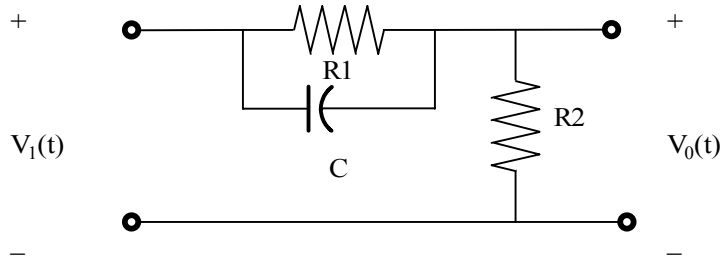

Suggested Solution

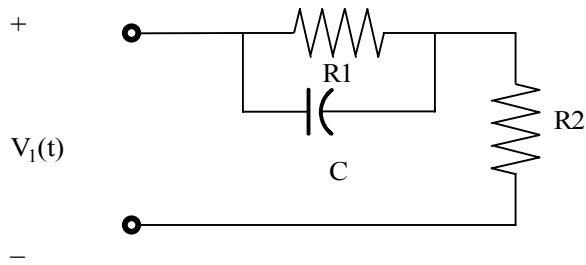

$$Z_{EQ} = R_1 \parallel \frac{1}{j\omega C} = \frac{R_1}{1 + j\omega R_1 C}$$

$$\frac{V_o}{V_i} = \frac{R_2}{R_2 + Z_{EQ}} = \frac{(1 + j\omega R_1 C) R_2}{R_1 + R_2 + j\omega R_1 R_2 C}$$

$$\frac{V_o}{V_i} = \left(\frac{R_2}{R_1 + R_2} \right) \left(\frac{(1 + j\omega R_1 C)}{(1 + j\omega R C)} \right) \text{ WHERE}$$

$$R = R_1 \parallel R_2 < R_1$$

$$W_z = \frac{1}{RC}$$

$$W_p = \frac{1}{RC}$$

$$W_p > W_z$$

NETWORK IS A HIGHER FILTER.

Problem 11.57

Determine what type of filter the network shown in fig 11.57 represents by determining the voltage transfer function.

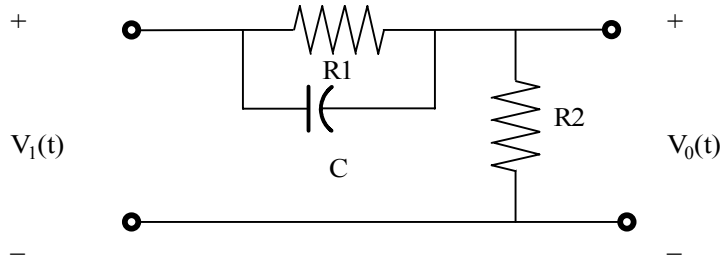

Suggested Solution

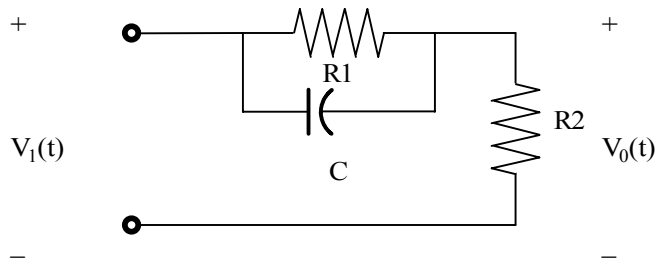

$$Z_{EQ} = R_1 \parallel \frac{1}{j\omega L} = \frac{j\omega L R_1}{R_1 + j\omega L}$$

$$G_V = \frac{V_O}{V_i} = \frac{R_2}{R_2 + Z_{EQ}} = \frac{(R_1 + j\omega L)R_2}{R_1 R_2 + j\omega L R_1 + j\omega L R_1}$$

$$G_V = \frac{1 + \frac{j\omega L}{R_1}}{1 + \frac{j\omega L}{R}}$$

$$R = R_1 \parallel R_2 < R_1$$

$$W_Z = \frac{R_1}{L}$$

$$W_P = \frac{R}{L}$$

$$W_P < W_Z$$

NETWORK IS A LOW-PASS FILTER.

Problem 11.58

Given the lattice network shown in fig 11.58 determine what type of filter this network represents by determining the voltage transfer function.

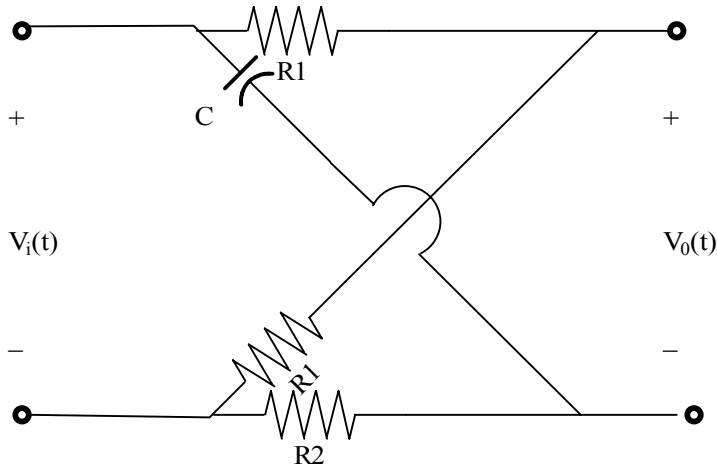

Suggested Solution

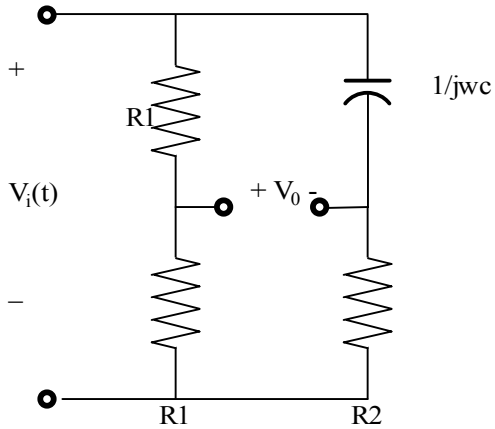

$$V_o = V_i \left[\frac{R_1}{R_1 + R_1} - \frac{R_1}{R_2 + \frac{1}{j\omega C}} \right] = V_i \left[\frac{1}{2} - \frac{j\omega C R_2}{1 + j\omega C R_2} \right] = \frac{1}{2} V_i \left[\frac{1 - j\omega C R_2}{1 + j\omega C R_2} \right]$$

THEREFORE

$$\left| \frac{V_o}{V_i} \right| = \frac{1}{2} \frac{\sqrt{1 + (\omega C R_2)^2}}{\sqrt{1 + (\omega C R_2)^2}} = 0.5$$

AN ALL PASS FILTER.

Problem 11.59

Given the network shown in fig 11.59 and employing the voltage follower analyzed in chapter 3 determine the voltage transfer function and its magnitude characteristic. What type of filter does the network represent?

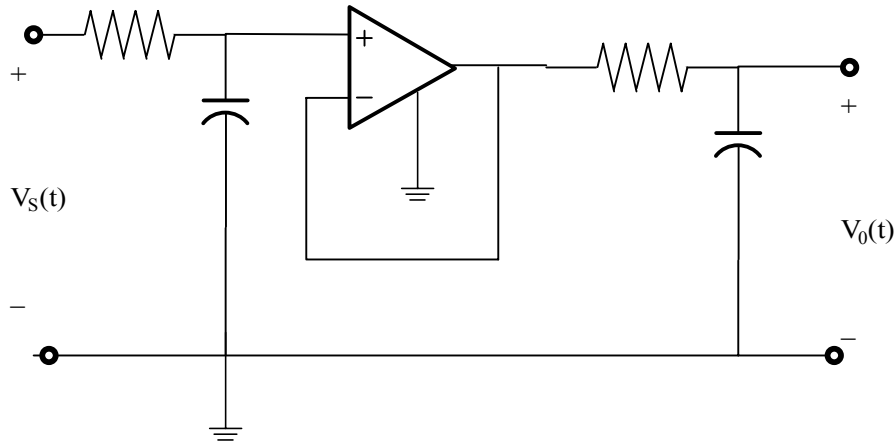

Suggested Solution

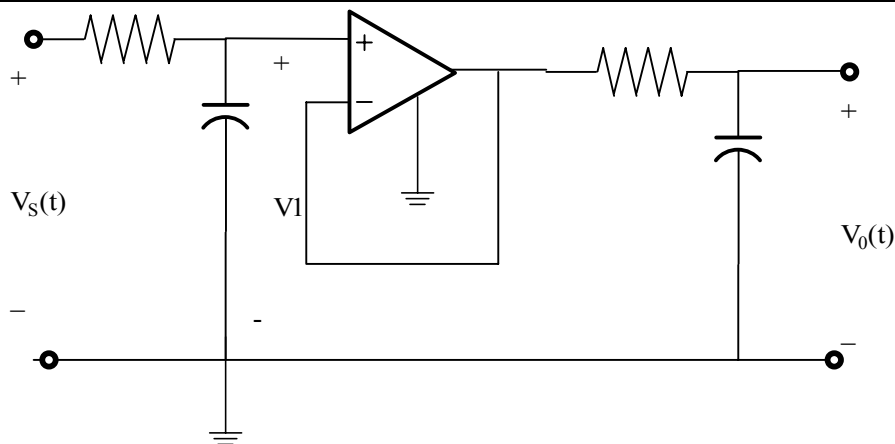

$$R = 1\Omega$$

$$C = 1F$$

$$\frac{V_1}{V_i} = \frac{1/j\omega}{(1/j\omega) + 1} = \frac{1}{1 + j\omega}$$

$$\frac{V_o}{V_1} = \left(\frac{1}{1 + j\omega} \right)^2$$

SECOND ORDER LOW-PASS

Problem 11.60

Determine the voltage transfer function and its magnitude characteristic for the network shown in fig 11.60 and identify the filter properties.

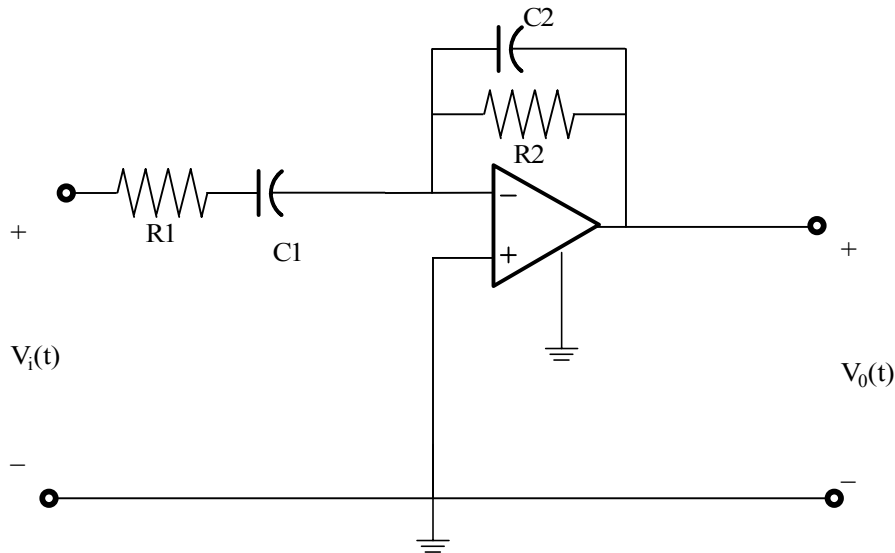

Suggested Solution

$$\frac{V_o}{V_i}(j\omega) = \frac{-Z_2(j\omega)}{Z_1(j\omega)}$$

$$Z_2(j\omega) = \frac{R_2 / j\omega C_2}{R_1 + \frac{1}{j\omega C_1}}$$

$$Z_1(j\omega) = R_1 + \frac{1}{j\omega C_1}$$

$$\therefore \frac{V_o}{V_i}(j\omega) = \frac{j\omega C_1 R_2}{(j\omega C_1 R_1 + 1)(j\omega C_2 R_2 + 1)}$$

THIS IS A 2ND ORDER BAND PASS FILTER.

Problem 11.61

Given the network in fig 11.61 find the transfer function and determine what type of filter the network represents.

$$\frac{V_o}{V_i}(j\omega)$$

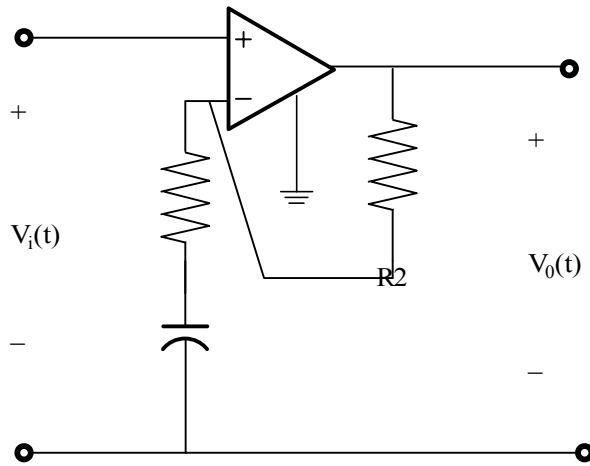

Suggested Solution

$$\frac{V_o}{V_i}(j\omega) = 1 + \frac{Z_2}{Z_1}$$

$$Z_2 = R_2 \qquad Z_1 = R_1 + \frac{1}{j\omega C}$$

$$\therefore \frac{V_o}{V_i}(j\omega) = 1 + \frac{j\omega C R_2}{(j\omega C R_1 + 1)} = \frac{(j\omega C (R_1 + R_2) + 1)}{(j\omega C R_1 + 1)}$$

this is a high pass filter

Problem 11.62

Repeat problem 11.54 for the network shown in fig 11.62.

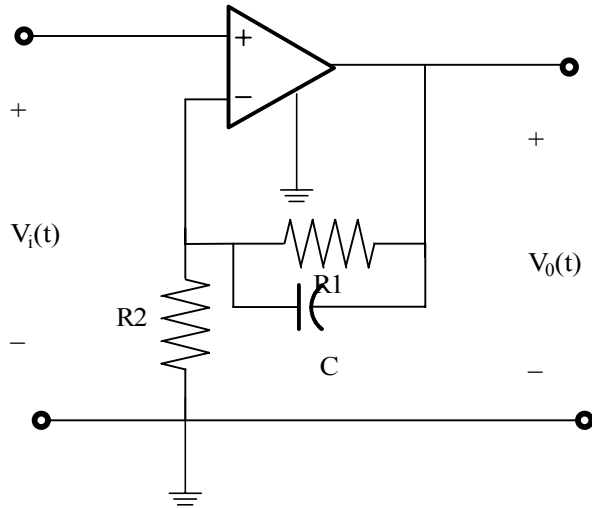

Suggested Solution

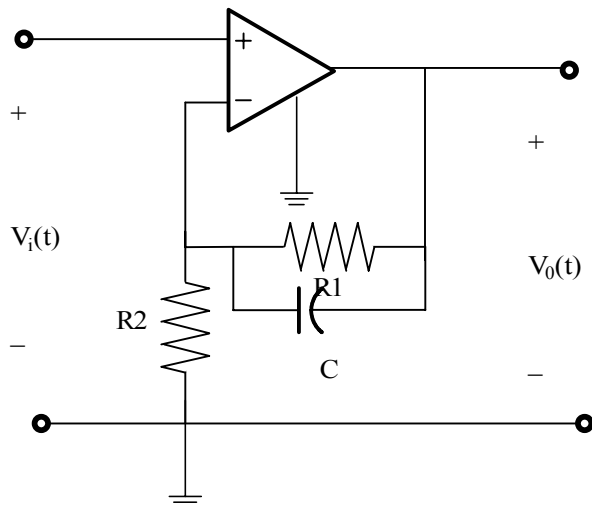

$$Z_{eq} = R_1 \parallel \frac{1}{j\omega C} = \frac{R_1}{1 + j\omega C R_1}$$

USING STANDARD NON-INVERTING GAIN EQUATION,

$$G_V = \frac{V_o}{V_i} = 1 + \frac{Z_{eq}}{R_2} = \frac{R_1 + R_2 + j\omega C R_1 R_2}{R_2(1 + j\omega C R_1)}$$

$$G_v = \left(1 + \frac{R_1}{R_2}\right) \left[\frac{(1 + j\omega CR)}{(1 + j\omega CR_1)} \right]$$

$$R = R_1 \parallel R_2$$

$$W_z = \frac{1}{CR}$$

$$W_p = \frac{1}{CR_1}$$

SINCE $R < R_1$, $W_z > W_p$

NETWORK IS A LOW-PASS FILTER.

Problem 11.63

In all OTA problem, the specifications are $g_m - I_{abc}$ sensitivity = 20, maximum $g_m = 1\text{mS}$ with range of 4 decades.

For the circuit in figure 11.50, find g_m and I_{abc} values required for a simulated resistance of 10Kohm.

Suggested Solution

$$i_o = g_m (-v_{in}) \& i_o = -i_{in}$$

$$v_{in} = -\frac{i_o}{g_m} = \frac{i_{in}}{g_m}$$

$$R_{eq} = \frac{v_{in}}{i_{in}} = \frac{1}{g_m}$$

$$\therefore g_m = 100\mu\text{S} \text{ and } I_{ARC} = 5\mu\text{A}$$

Problem 11.64

In all OTA problem, the specifications are $g_m - I_{abc}$ sensitivity = 20, maximum $g_m = 1\text{mS}$ with range of 4 decades.

For the circuit in figure 11.53, find g_m and I_{abc} values required for a simulated resistance of 10Kohm . Repeat for 750Kohm .

Suggested Solution

$$i_{o1} = -i_1 = -g_{m1}v_1^-$$

$$R_{eq} = \frac{1}{g_{m1}}$$

$$i_{o2} = -i_2 = -g_{m2}v_2^-$$

$$R_{eq} = \frac{1}{g_{m2}}$$

For $10\text{k}\Omega$

$$g_{m1} = g_{m2} = \frac{1}{10\text{k}} = 100\mu\text{S} \text{ and } I_{ARC} = 5\mu\text{A}$$

For $750\text{k}\Omega$

$$g_{m1} = g_{m2} = 1.33\mu\text{S} \text{ and } I_{ARC} = 66\mu\text{A}$$

Problem 11.65

Use the summing circuit in figure 11.51 to design a circuit that realizes the following function.

$$V_o = 7V_1 + 3V_2$$

Suggested Solution

$$i_{o1} + i_{o2} = i_o = i_{o3} = g_3 v_o$$

$$g_1 v_1 + g_2 v_2 = g_3 v_o$$

$$\therefore v_o = \frac{g_1}{g_3} v_1 + \frac{g_2}{g_3} v_2$$

$$\frac{g_1}{g_3} = 7, \frac{g_2}{g_3} = 3$$

\therefore arbitrarily select

$$g_3 = 100 \mu S$$

$$g_2 = 700 \mu S$$

$$g_1 = 300 \mu S$$

$$\text{and } I_{ARC1} = 5 \mu A, I_{ARC2} = 35 \mu A \text{ and } I_{ARC3} = 15 \mu A$$

Problem 11.66

Prove that the circuit in figure p11.66 is a simulated inductor. Find the inductance in terms of C , g_{m1} and g_{m2} .

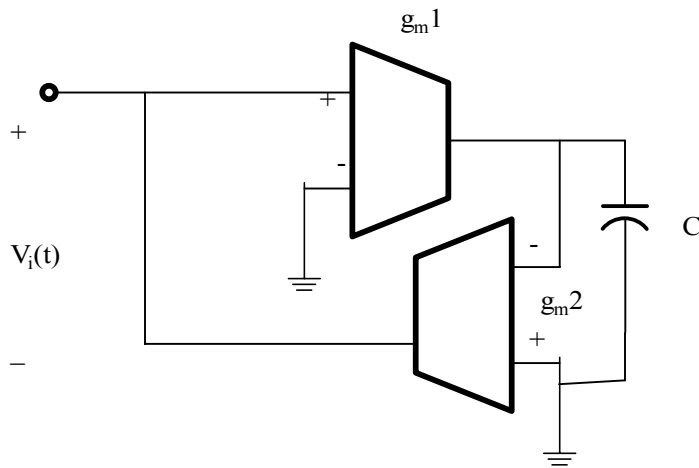

Suggested Solution

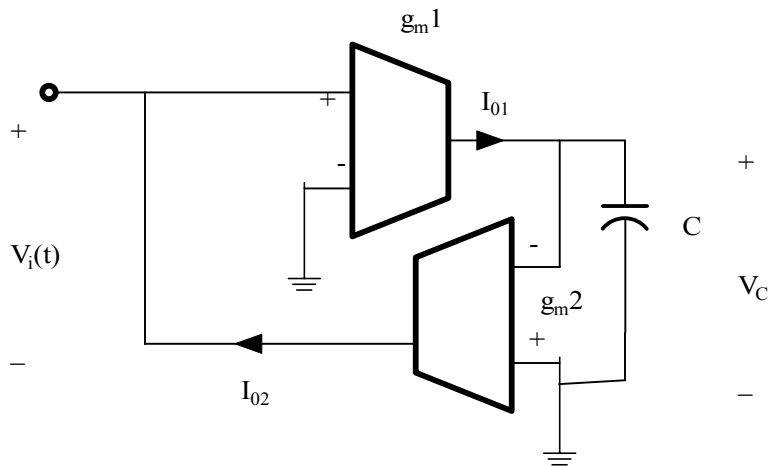

$$i_{o1} = g_{m1}v_{in} = c \frac{dv_i}{dt}$$

$$i_{o2} = -g_{m2}v_i = i_{in}$$

$$\therefore g_{m1}v_{in} = c \frac{dv_i}{dt} = -\frac{c}{g_{m2}} \frac{di_{o2}}{dt} = \frac{c}{g_{m2}} \frac{di_{in}}{dt}$$

$$v_{in} = \frac{c}{g_{m1}g_{m2}} \frac{di_{in}}{dt} \quad \text{or} \quad i_{eq} = \frac{c}{g_{m1}g_{m2}}$$

Problem 11.67

In the Tow-Thomas biquad in figure 11.57, $C_1=20\text{pF}$, $C_2=10\text{ pF}$, $g_m = 10\mu\text{S}$, $g_{m2}= 80\mu\text{S}$, $g_{m3}=10\mu\text{S}$. find the low pass filter transfer function for the $V_{i1} - V_{o2}$ i/p- o/p pair. Plot the corresponding Bode plot.

Suggested Solution

$$\omega_o = \sqrt{\frac{g_1 g_2}{c_1 c_2}} = 2Mr / s$$

$$\frac{\omega_o}{Q} = \frac{g_3}{c_2} = 1Mr / s$$

$$\frac{v_{o2}}{v_{i1}} = \frac{\omega_o^2}{s^2 + \frac{\omega_o}{Q}s + \omega_o^2} = \frac{4*10^{12}}{s^2 + 10^6 s + 4*10^{12}}$$

Problem 11.68

Find the transfer function of the OTA filter in figure 11.68. Express ω_0 and Q in terms of the capacitances and transconductances. What kind of filter is it.

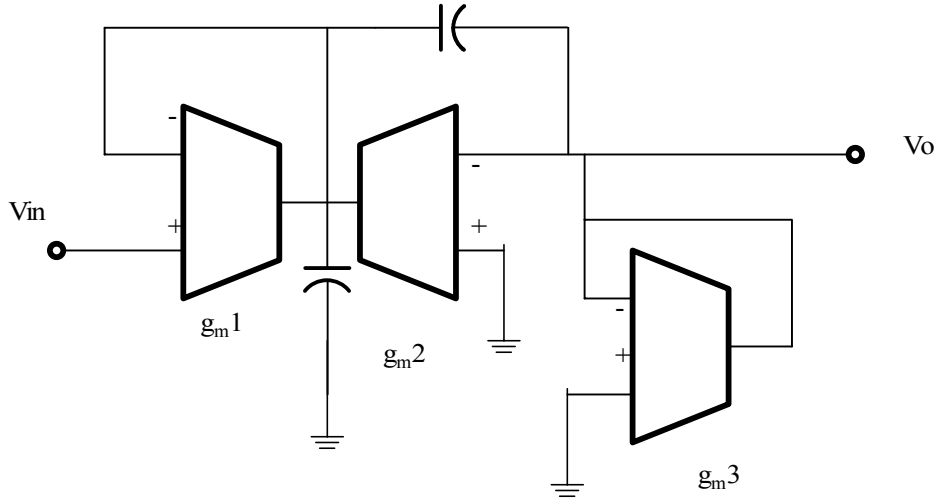

Suggested Solution

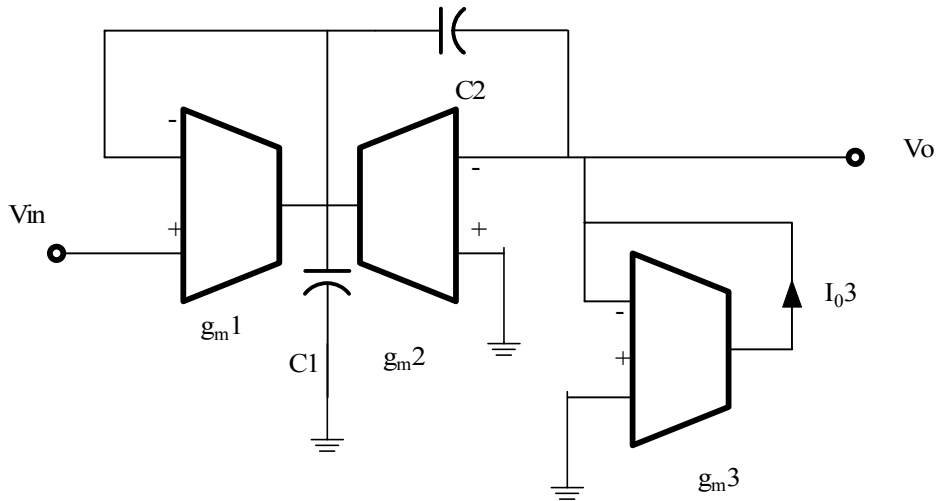

$$I_{o1} = g_1(V_{in} - V_x)$$

$$I_{o2} = -g_2V_o$$

$$I_{o3} = -g_3V_o$$

$$I_{o1} + I_{o2} + (V_o - V_x)j\omega c_2 = j\omega c_1V_x$$

$$I_{o3} = (V_o - V_x)j\omega c_2$$

making substitutions.

$$g_1(V_{in} - V_x) - g_2V_o + j\omega c_2V_o - j\omega c_2V_x = j\omega c_1V_x$$

$$-g_3V_o = j\omega c_2V_o - j\omega c_2V_x$$

from the last eq

$$j\omega c_2V_x = g_3V_o + j\omega c_2V_o$$

$$V_x = \left(1 + \frac{g_3}{j\omega c_2}\right)V_o$$

then

$$g_1V_{in} - g_1\left(1 + \frac{g_3}{j\omega c_2}\right)V_o - g_2V_o + j\omega c_2V_o - j\omega c_2\left(1 + \frac{g_3}{j\omega c_2}\right)V_o = j\omega c_1\left(1 + \frac{g_3}{j\omega c_2}\right)V_o$$

$$g_1V_{in} = \left[\frac{j\omega c_2(g_1 + g_2 + g_3) + g_1g_3 - \omega^2 c_1c_2 + j\omega g_1g_3}{j\omega c_1} \right] V_o$$

$$j\omega c_1g_1V_{in} = \left[-\omega^2 c_1c_2 + j\omega c_2(g_1 + g_2 + g_3) + g_3c_1 \right] V_o$$

$$\frac{V_o}{V_{in}} = \frac{j\omega c_1g_1}{-\omega^2 + j\omega \left[\frac{(g_1 + g_2 + g_3) + g_3c_1/c_2}{c_1} \right] + \frac{g_1g_3}{c_1c_2}}$$

$$\omega_o = \sqrt{\frac{g_1g_3}{c_1c_2}}$$

$$Q = \frac{\sqrt{g_1g_2c_1c_2}}{c_2(g_1 + g_2 + g_3) + g_3c_1}$$

This is a band pass filter.

Problem 11.69

Find the transfer function of the OTA filter in fig 11.69. Express ω_0 and Q in terms of the capacitances and transconductances. What kind of filters is it?

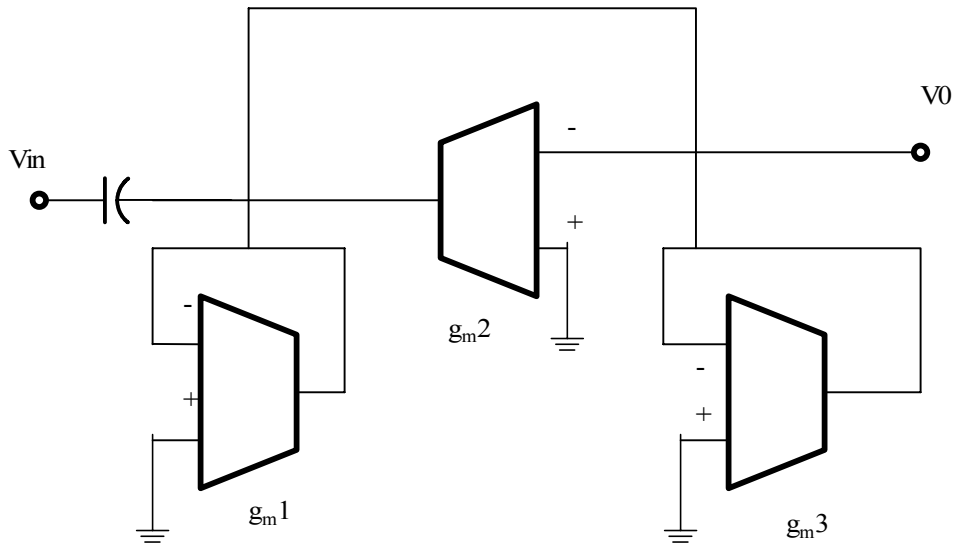

Suggested Solution

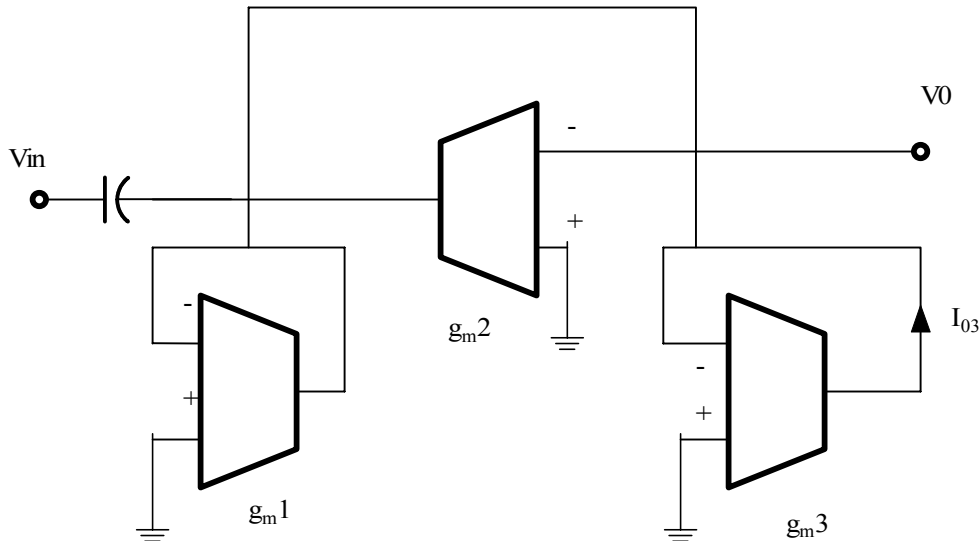

$$I_{o1} = -g_1 V_x$$

$$I_{o2} = -g_2 V_o$$

$$(V_{in} - V_x)j\omega c_1 + I_{o1} + I_{o2} + (V_o - V_x)j\omega c_2 = 0$$

$$j\omega c_1 V_{in} - j\omega c_1 V_x - g_1 V_x - g_2 V_o + j\omega c_2 V_o - j\omega c_2 V_x = 0$$

$$j\omega c_1 V_{in} - (j\omega c_1 + g_1 + j\omega c_2)V_x + (j\omega c_2 - g_2)V_o = 0$$

in addition

$$(V_o - V_x)j\omega c_2 = -g_3 V_o$$

or

$$j\omega c_2 V_x = (j\omega c_2 + g_3) V_o$$

$$V_x = \left(\frac{j\omega c_2 + g_3}{j\omega c_2} \right) V_o = \left(1 + \frac{g_3}{j\omega c_2} \right) V_o$$

then,

$$j\omega c_1 V_{in} = \left[(j\omega c_1 + g_1 + j\omega c_2) \left(1 + \frac{g_3}{j\omega c_2} \right) - j\omega c_2 + g_2 \right] V_o$$

$$j\omega c_1 V_{in} = \left[\frac{-\omega^2 c_1 c_2 + j\omega c_2 ((g_1 + g_2 + g_3) + g_3 c_1 / c_2) + g_1 g_3}{j\omega c_2} \right] V_o$$

$$\frac{V_o}{V_{in}} = \frac{-\omega^2 c_1 c_2}{-\omega^2 c_1 c_2 + j\omega c_2 (g_1 + g_2 + g_3 + g_3 (c_1 / c_2)) + g_1 g_3}$$

$$\frac{V_o}{V_{in}} = \frac{-\omega^2}{-\omega^2 + j\omega \left(\frac{g_1 + g_2 + g_3 + g_3 (c_1 / c_2)}{c_1} \right) + \frac{g_1 g_3}{c_1 c_2}}$$

Therefore,

$$\omega_o = \sqrt{\frac{g_1 g_3}{c_1 c_2}}$$

$$Q = \frac{\sqrt{g_1 g_2 c_1 c_2}}{c_2 (g_1 + g_2 + g_3) + g_3 c_1}$$

A high pass filter.

Problem 11.70

Refer to the ac/dc converter low-pass filter application of example 11.25. if we put the converter to use powering a calculator, the load current can be modeled by a resistor as shown in fig 11.25. The load resistor will affect both the magnitude of the dc component of V_{of} and the pole frequency. Plot both the pole frequency and the ratio of the 60-Hz component of the o/p voltage to the dc component of V_{of} versus R_L for 100ohm less than equal to R_L , which is less than equal to 100 kohm . Comment on the advisable limitations on R_L if (a) the dc component of V_{of} is to remain within 20 % of its 9-v ideal value: (b) the 60 Hz component of V_{of} remains less than 15% of the dc component.

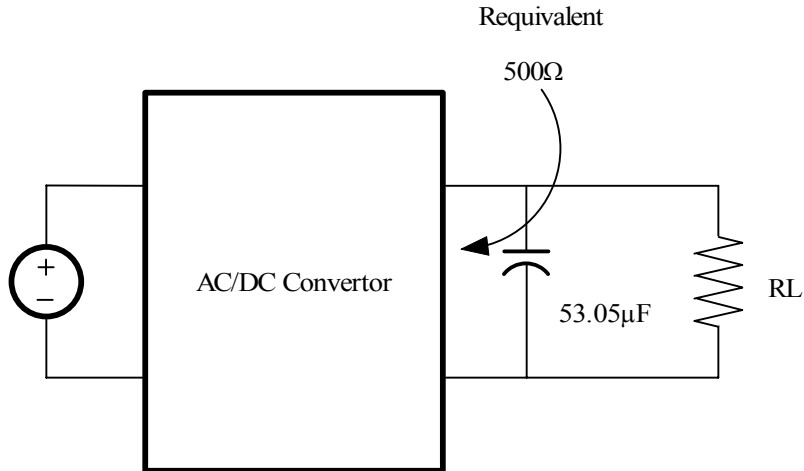

Suggested Solution

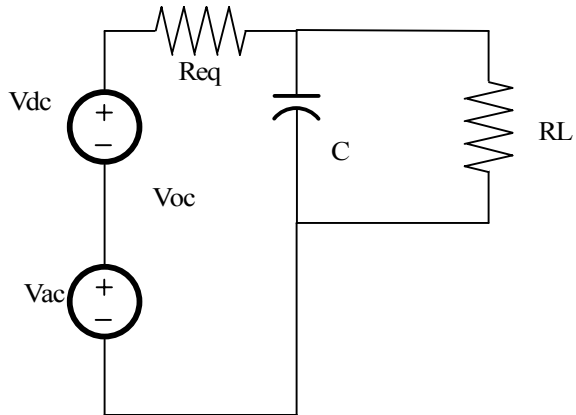

THE CIRCUIT BELOW MODELS THE SITUATION DESCRIBED IN THE TEXT.

$$H = \frac{V_o}{V_s} = \frac{R_L}{R_L + R_{eq} + j\omega C R_L} = \frac{R_L}{R_L + R_{eq}} \left[\frac{1}{1 + j\omega C R} \right]$$

WHERE $R = R_L \parallel R_{eq}$

$$a). H(j\omega) = \frac{R_L}{R_L + R_{eq}} \geq 0.8$$

$$R_L \geq 2K\Omega$$

$$b). \left| \frac{H(j377)}{H(j\omega)} \right| < 0.15$$

$$\text{OR, } R > 330\Omega$$

$$\text{Since, } R = R_{eq} \parallel R_L$$

$$R_L > 970.6\Omega$$

Requirement a) is more stringent.

Problem 11.71

Referring to Ex 11.28 design a notch filter for the tape deck for use in Europe, where power utilities generate at 50 Hz.

Suggested Solution

$$R_{tape} = 50\Omega$$

$$R_{amp} = 1K\Omega$$

$$W_z = \frac{1}{\sqrt{LC}} = 2\pi(50)$$

CHOOSE YEILDS,

$$C=100\mu F$$

$$L=101mH$$

Problem 11FE-1

Determine the resonant frequency of the circuit in fig 11PFE-1 and find the voltage V_0 at resonance.

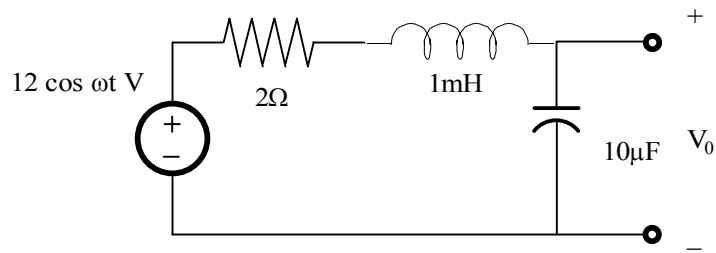

Suggested Solution

$$\omega_o = \frac{1}{\sqrt{LC}} = 10kr / s$$

$$I = \frac{12\angle 0^\circ}{2} = 6\angle 0^\circ$$

$$v_c = \frac{I}{j\omega c} = \frac{6\angle -90^\circ}{10^{-4}10^{-5}} = 60\angle -90^\circ v$$

$$\text{also } |v_c| = Qv_s = \frac{\omega_o L}{R}(12) = 60v$$

Problem 11FE-2

Given the series circuit in fig 11PFE-2, determine the resonant frequency and find the value of R so that the BW of the network about the resonant frequency is 200 r/s.

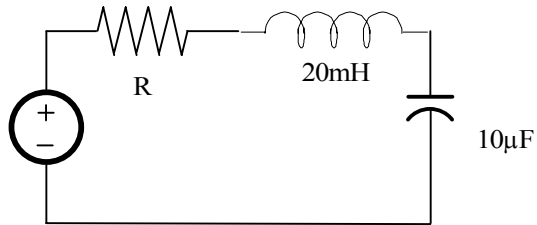

Suggested Solution

$$\omega_o = \frac{1}{\sqrt{LC}} = 1kr/s$$

$$Q = \frac{\omega_o L}{R} \text{ and } BW = \frac{\omega_o}{Q} \therefore BW = \frac{R}{L} \text{ and } 200 = \frac{R}{0.00020} \therefore R = 4\Omega$$

Problem 11FE-3

Given the low-pass filter circuit in fig 11PFE-3, determine the frequency in Hz at which the output is down from the dc, or very low frequency, output.

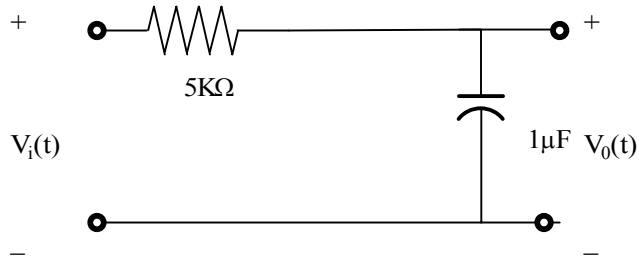

Suggested Solution

$$\frac{v_o}{v_{in}} = \frac{1/j\omega c}{R + 1/j\omega c} = \frac{1}{1 + j\omega R c} \therefore 3dB \text{ point}$$

$$\omega = \frac{1}{RC} = 200 \text{ rad/s}$$

$$f_{3dB} = 31.83 \text{ Hz}$$

Problem 11FE-4

Given the band-pass shown in fig 11PFE-4, find the components L and R necessary to provide a resonant frequency of 1000 r/s and a BW of 100 r/s.

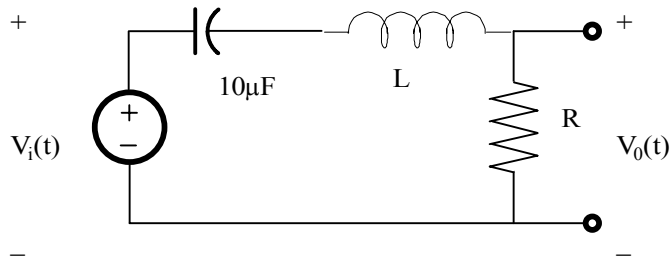

Suggested Solution

$$\omega = \frac{1}{\sqrt{LC}} \Rightarrow L = 100mH$$

$$BW = \frac{R}{L} \Rightarrow R = 10\Omega$$

Problem 11FE-5

Given the low-pass shown in fig 11PFE-5, find the half-power frequency and the gain of this circuit, if the source frequency is 8Hz.

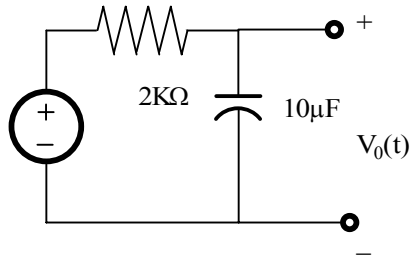

Suggested Solution

$$\omega = \frac{1}{RC} = 50 \text{ rad/s}$$

$$f = \frac{50}{2\pi} = 7.96 \text{ Hz}$$

The dc gain is unity and the gain at the Half Power Frequency 7.98 is approximate to 8 Hz is by definition 0.707 of the dc gain.

Problem 12.1

Find the Laplace Transform of the function

$$f(t) = te^{-at} \delta(t-1)$$

Suggested Solution

$$F(s) = \int_0^{\infty} te^{-at} \delta(t-1) e^{-st} dt$$

let

$$g(t) = te^{-at}$$

$$F(s) = \int_0^{\infty} g(t) \delta(t-1) e^{-st} dt = g(1) e^{-s(1)} = e^{-(s+a)}$$

Problem 12.2

Find the Laplace transform of the function

$$f(t) = te^{-a(t-1)}\delta(t-1)$$

Suggested Solution

$$f(t) = te^{-a(t-1)}\delta(t-1)$$

let

$$g(t) = te^{-(a-1)t}$$

$$F(s) = \int_0^{\infty} g(t)\delta(t-1)e^{-st} dt = g(1)e^{-s(1)} = e^{-s}$$

$$F(s) = e^{-s}$$

Problem 12.3

If

$$f(t) = e^{-at} \cos(\omega t)$$

show

$$F(s) = \frac{s+a}{(s+a)^2 + (\omega)^2}$$

Suggested Solution

$$F(s) = \int_0^{\infty} e^{-at} e^{-st} \cos(\omega t) dt = \int_0^{\infty} e^{-(a+s)t} \left[\frac{e^{-j\omega t} + e^{j\omega t}}{2} \right] dt$$

$$F(s) = \frac{1}{2} \left[\int_0^{\infty} e^{-(s+a-j\omega)t} dt + \int_0^{\infty} e^{-(s+a+j\omega)t} dt \right]$$

$$= \frac{1}{2} \left[\frac{-1}{s+a-j\omega} e^{-(s+a-j\omega)t} \Big|_0^{\infty} - \frac{1}{s+a+j\omega} e^{-(s+a+j\omega)t} \Big|_0^{\infty} \right]$$

$$= \frac{1}{2} \left[\frac{-1}{s+a-j\omega} + \frac{1}{s+a+j\omega} \right]$$

$$= \frac{1}{2} \left[\frac{s+a+j\omega + s+a-j\omega}{(s+a-j\omega)(s+a+j\omega)} \right]$$

$$F(s) = \frac{s+a}{(s+a)^2 + (\omega)^2}$$

$$F(s) = \frac{s+a}{(s+a)^2 + (\omega)^2}$$

Problem 12.4

Find $F(s)$ if

$$f(t) = e^{-at} \sin(\omega t) u(t-1)$$

Suggested Solution

$$f(t) = e^{-at} \sin(\omega t) u(t-1)$$

$$\begin{aligned} F(s) &= e^{-s} L[e^{-a(t+1)} \sin(\omega)(t+1)] \\ &= e^{-(s+a)} L[e^{-at} \sin \omega(t+1)] \\ &= e^{-(s+a)} L[e^{-at} (\sin \omega t \cos \omega + \cos \omega t \sin \omega)] \\ &= e^{-(s+a)} \left[\frac{\omega \cos \omega}{(s+a)^2 + (\omega)^2} + \frac{(s+a) \sin \omega}{(s+a)^2 + (\omega)^2} \right] \end{aligned}$$

$$F(s) = e^{-(s+a)} \left[\frac{\omega \cos \omega}{(s+a)^2 + (\omega)^2} + \frac{(s+a) \sin \omega}{(s+a)^2 + (\omega)^2} \right]$$

Problem 12.5

If

$$f(t) = t \cos(\omega t)u(t-1)$$

find $F(s)$

Suggested Solution

$$f(t) = t \cos(\omega t)u(t-1),$$

$$F(s) = e^{-s}L[(t+1) \cos \omega(t+1)]$$

$$= e^{-s}L[(t+1)(\cos \omega t \cos \omega - \sin \omega t \sin \omega)]$$

$$= e^{-s}L[t \cos \omega t \cos \omega + \cos \omega t \cos \omega - t \sin \omega t \sin \omega - \sin \omega t \sin \omega]$$

$$L[\cos \omega t \cos \omega] = \frac{s \cos \omega}{s^2 + \omega^2}$$

$$L[\sin \omega t \sin \omega] = \frac{s \sin \omega}{s^2 + \omega^2}$$

$$L[t \cos \omega t \cos \omega] = \frac{-d}{ds} \left(\frac{s \cos \omega}{s^2 + \omega^2} \right) = - \left[\frac{(s^2 + \omega^2) \cos \omega - s \cos \omega (2s)}{(s^2 + \omega^2)^2} \right]$$

$$L[t \sin \omega t \sin \omega] = \frac{-d}{ds} \left(\frac{\omega \sin \omega}{s^2 + \omega^2} \right) = - \left[\frac{\omega \sin \omega (2s)}{(s^2 + \omega^2)^2} \right]$$

$$F(s) = e^{-s} \left[\frac{2s^2 \cos \omega - (s^2 + \omega^2) \cos \omega}{(s^2 + \omega^2)^2} + \frac{2s\omega \sin \omega}{(s^2 + \omega^2)^2} + \frac{s \cos \omega}{s^2 + \omega^2} + \frac{\omega \sin \omega}{s^2 + \omega^2} \right]$$

$$F(s) = e^{-s} \left[\frac{2s^2 \cos \omega - (s^2 + \omega^2) \cos \omega}{(s^2 + \omega^2)^2} + \frac{2s\omega \sin \omega}{(s^2 + \omega^2)^2} + \frac{s \cos \omega}{s^2 + \omega^2} + \frac{\omega \sin \omega}{s^2 + \omega^2} \right]$$

Problem 12.6

Find $F(s)$ if

$$f(t) = te^{-at}u(t-4)$$

Suggested Solution

$$f(t) = te^{-at}u(t-4)$$

$$\begin{aligned} F(s) &= e^{-4s} L[(t+4)e^{-a(t+4)}] \\ &= e^{-4(s+a)} L[(t+4)e^{-at}] \\ &= e^{-4(s+a)} L[te^{-at} + 4e^{-at}] \\ &= e^{-4(s+a)} \left[\frac{1}{(s+a)^2} + \frac{4}{(s+a)} \right] \end{aligned}$$

$$F(s) = e^{-4(s+a)} \left[\frac{1}{(s+a)^2} + \frac{4}{(s+a)} \right]$$

Problem 12.7

Use the shifting Theorem to determine $L\{f(t)\}$ where

$$f(t) = [e^{-(t-2)} - e^{-2(t-2)}]u(t-2)$$

Suggested Solution

$$f(t) = [e^{-(t-2)} - e^{-2(t-2)}]u(t-2)$$

The shifting Theorem states

$$L[f(t-t_0)u(t-t_0)] = e^{-t_0s}F(s)$$

$$L[f(t-t_0)u(t-t_0)] = e^{-t_0s}F(s)$$

let

$$g(t) = (e^{-t} - e^{-2t})u(t)$$

so

$$G(s) = \frac{1}{s+1} - \frac{1}{s+2}$$

$$F(s) = e^{-2s}G(s)$$

$$F(s) = e^{-2s} \left[\frac{1}{s+1} - \frac{1}{s+2} \right]$$
$$F(s) = \frac{e^{-2s}}{(s+1)(s+2)}$$

Problem 12.8

Use the shifting Theorem to determine $L\{f(t)\}$ where

$$f(t) = [e^{-(t-2)} - e^{-(t-1)}]u(t-1)$$

Suggested Solution

$$f(t) = [e^{-(t-2)} - e^{-(t-1)}]u(t-1)$$

let

$$g(t) = (t + e^{-t})u(t-1)$$

so

$$G(s) = \frac{1}{s+1} + \frac{1}{s^2}$$

$$F(s) = e^{-s}G(s)$$

$$F(s) = e^{-2s} \left[\frac{1}{s+1} + \frac{1}{s^2} \right]$$

$$F(s) = e^{-2s} \left[\frac{1}{s+1} + \frac{1}{s^2} \right]$$

Problem 12.9

Use Property Number 5 to find $L\{f(t)\}$ if

$$f(t) = e^{-at}u(t-1)$$

Suggested Solution

$$f(t) = e^{-at}u(t-1)$$

let

$$g(t) = e^{-at}$$

Thm 5:

$$L[g(t)u(t-t_0)] = e^{-t_0s}L[g(t+t_0)]$$

so

$$L[e^{-at}u(t-1)] = e^{-s}L[e^{-a(t+1)}] = e^{-(s+a)}L[e^{-at}]$$

since

$$L[e^{-at}] = \frac{1}{s+a}$$

$$F(s) = \frac{e^{-(s+a)}}{s+1}$$

$$F(s) = \frac{e^{-(s+a)}}{s+1}$$

Problem 12.10

Use Property Number 6 to find $L\{f(t)\}$ if

$$f(t) = te^{-at}u(t-1)$$

Suggested Solution

$$f(t) = te^{-at}u(t-1)$$

let

$$g(t) = tu(t-1)$$

Thm 6:

$$L[e^{-at}g(t)] = G(s+a)$$

$$L[g(t)] = L[tu(t-1)] = e^{-s}L[t-1] = e^{-s}\left(\frac{1}{s^2} + \frac{1}{s}\right) = G(s)$$

$$F(s) = G(s+a) = e^{-(s+a)}\left(\frac{1}{(s+a)^2} + \frac{1}{(s+a)}\right)$$

$$F(s) = G(s+a) = e^{-(s+a)}\left(\frac{1}{(s+a)^2} + \frac{1}{(s+a)}\right)$$

Problem 12.11

Given the following functions $F(s)$, find $f(t)$,

$$F(s) = \frac{4}{(s+1) + (s+2)}$$

$$F(s) = \frac{10s}{(s+1) + (s+4)}$$

Suggested Solution

A.

$$F(s) = \frac{4}{(s+1) + (s+2)}$$

for

$$s = -1$$

$$\frac{4}{s+2} = 4 = k_1$$

for

$$s = -2$$

$$\frac{4}{s+1} = -4 = k_2$$

$$f(t) = (4e^{-t} - 4e^{-2t})u(t)$$

so

$$F(s) = \frac{4}{s+2} - \frac{4}{s+1}$$

$$f(t) = (4e^{-t} - 4e^{-2t})u(t)$$

B.

$$F(s) = \frac{10s}{(s+1) + (s+4)}$$

for

$$s = -1$$

$$\frac{10s}{s+4} = \frac{-10}{3} = k_1$$

for

$$s = -4$$

$$\frac{10s}{s+1} = \frac{40}{3} = k_2$$

so

$$F(s) = \frac{-10/3}{s+1} - \frac{40/3}{s+4}$$

$$f(t) = \left(\frac{-10}{3} e^{-t} + \frac{40}{3} e^{-4t} \right) u(t)$$

$$f(t) = \left(\frac{-10}{3} e^{-t} + \frac{40}{3} e^{-4t} \right) u(t)$$

Problem 12.12

Given the following functions $F(s)$, find $f(t)$

$$F(s) = \frac{s+10}{(s+4)(s+6)}$$

$$F(s) = \frac{24}{(s+2)(s+8)}$$

Suggested Solution

A.

$$F(s) = \frac{s+10}{(s+4)(s+6)}$$

for

$$s = -4$$

$$\frac{s+10}{s+6} = 3 = k_1$$

for

$$s = -6$$

$$\frac{s+10}{s+4} = -2 = k_2$$

$$f(t) = (3e^{-4t} - 2e^{-6t})u(t)$$

so

$$F(s) = \frac{3}{s+4} - \frac{2}{s+6}$$

$$f(t) = (3e^{-4t} - 2e^{-6t})u(t)$$

B.

$$F(s) = \frac{24}{(s+2)(s+8)}$$

for

$$s = -2$$

$$\frac{24}{s+8} = 6 = k_1$$

for

$$s = -8$$

$$\frac{24}{s+2} = -4 = k_2$$

$$f(t) = (4e^{-2t} - 4e^{-8t})u(t)$$

so

$$F(s) = \frac{4}{s+2} - \frac{4}{s+8}$$

$$f(t) = (4e^{-2t} - 4e^{-8t})u(t)$$

Problem 12.13

Given the following functions $F(s)$, find $f(t)$ if

$$F(s) = \frac{s+1}{s(s+2)(s+3)}$$

$$F(s) = \frac{s^2+s+1}{s(s+2)(s+1)}$$

Suggested Solution

A.

$$F(s) = \frac{s+1}{s(s+2)(s+3)}$$

$$\text{for } s=0, \frac{s+1}{(s+2)(s+3)} = 1/6 = k_1$$

$$\text{for } s=-2, \frac{s+1}{s(s+3)} = \frac{1}{2} = k_2$$

$$\text{for } s=-3, \frac{s+1}{s(s+2)} = \frac{-2}{3} = k_3$$

$$\text{so } F(s) = \frac{1/6}{s} + \frac{1/2}{s+2} - \frac{2/3}{s+3}$$

$$\text{and } f(t) = \left(\frac{1}{6} + \frac{1}{2}e^{-2t} - \frac{2}{3}e^{-3t} \right) u(t)$$

$$f(t) = \left(\frac{1}{6} + \frac{1}{2}e^{-2t} - \frac{2}{3}e^{-3t} \right) u(t)$$

B.

$$F(s) = \frac{s^2+s+1}{s(s+2)(s+1)}$$

$$\text{for } s=0, \frac{s^2+s+1}{(s+2)(s+3)} = 1/2 = k_1$$

$$\text{for } s=-1, \frac{s^2+s+1}{s(s+2)} = -1 = k_2$$

$$\text{for } s=-2, \frac{s^2+s+1}{s(s+2)} = \frac{3}{2} = k_3$$

$$\text{so } F(s) = \frac{1/2}{s} + \frac{-1}{s+1} + \frac{3/2}{s+2}$$

$$\text{and } f(t) = \left(\frac{1}{2} + e^{-t} + \frac{3}{2}e^{-2t} \right) u(t)$$

$$f(t) = \left(\frac{1}{2} + e^{-t} + \frac{3}{2}e^{-2t} \right) u(t)$$

Problem 12.14

Given the following functions $F(s)$, find $f(t)$.

$$F(s) = \frac{s^2 + 5s + 4}{(s+2)(s+4)(s+6)}$$

$$F(s) = \frac{(s+3)(s+6)}{s(s^2 + 8s + 12)}$$

Suggested Solution

A.

$$F(s) = \frac{s^2 + 5s + 4}{(s+2)(s+4)(s+6)}$$

$$F(s) = \frac{(s+1)(s+4)}{(s+2)(s+4)(s+6)} = \frac{(s+1)}{(s+2)(s+6)} = \frac{A}{s+2} + \frac{B}{s+6}$$

$$A = F(s)(s+2)|_{s=-2} = \frac{-1}{4}$$

$$B = F(s)(s+6)|_{s=-6} = \frac{5}{4}$$

$$F(s) = \frac{5/4}{s+6} - \frac{1/4}{s+2}$$

$$f(t) = \left(\frac{5}{4} + e^{-6t} - \frac{1}{4}e^{-2t}\right)u(t)$$

$$f(t) = \left(\frac{5}{4} + e^{-6t} - \frac{1}{4}e^{-2t}\right)u(t)$$

B.

$$F(s) = \frac{(s+3)(s+6)}{s(s^2 + 8s + 12)}$$

$$F(s) = \frac{(s+3)(s+6)}{s(s+2)(s+6)} = \frac{(s+3)}{s(s+2)} = \frac{A}{s} + \frac{B}{s+2}$$

$$A = F(s)s|_{s=0} = \frac{3}{2}$$

$$B = F(s)(s+2)|_{s=-2} = \frac{-1}{2}$$

$$F(s) = \frac{3/2}{s} - \frac{1/2}{s+2} + \frac{3/2}{s+2}$$

$$f(t) = \left(\frac{3}{2} - \frac{1}{2}e^{-2t}\right)u(t)$$

$$f(t) = \left(\frac{3}{2} - \frac{1}{2}e^{-2t}\right)u(t)$$

Problem 12.15

Given the following functions $F(s)$, find $f(t)$.

$$F(s) = \frac{s^2 + 7s + 12}{(s+2)(s+4)(s+6)}$$

$$F(s) = \frac{(s+3)(s+6)}{s(s^2 + 10s + 24)}$$

Suggested Solution

A.

$$F(s) = \frac{s^2 + 7s + 12}{(s+2)(s+4)(s+6)}$$

$$F(s) = \frac{(s+3)(s+4)}{(s+2)(s+4)(s+6)} = \frac{(s+3)}{(s+6)(s+2)} = \frac{A}{s+6} + \frac{B}{s+2}$$

$$F(s) = \frac{1/4}{s+2} + \frac{3/4}{s+6}$$

$$f(t) = \left(\frac{1}{4}e^{-2t} + \frac{3}{4}e^{-6t}\right)u(t)$$

$$f(t) = \left(\frac{1}{4}e^{-2t} + \frac{3}{4}e^{-6t}\right)u(t)$$

B.

$$F(s) = \frac{(s+3)(s+6)}{s(s^2 + 10s + 24)}$$

$$F(s) = \frac{(s+3)(s+6)}{(s)(s+4)(s+6)} = \frac{(s+3)}{(s+6)(s+2)} = \frac{A}{s} + \frac{B}{s+4}$$

$$F(s) = \frac{3/4}{s} + \frac{1/4}{s+4}$$

$$f(t) = \left(\frac{3}{4} + \frac{1}{4}e^{-4t}\right)u(t)$$

$$f(t) = \left(\frac{3}{4} + \frac{1}{4}e^{-4t}\right)u(t)$$

Problem 12.16

Given the following functions $F(s)$ find $f(t)$

$$F(s) = \frac{s^2 + 7s + 12}{(s+2)(s+4)(s+6)}$$

$$F(s) = \frac{10(s+2)}{(s^2 + 4s + 5)}$$

Suggested Solution

A.

$$F(s) = \frac{s^2 + 7s + 12}{(s+2)(s+4)(s+6)}$$

Matlab code

EDU» syms s t

EDU» ilaplace((s^2+7*s+12)/(s+2)/(s+4)/(s+6))

$$f(t) = \left(\frac{3}{4}e^{-6t} + \frac{1}{4}e^{-2t}\right)$$

ans =

3/4*exp(-6*t)+1/4*exp(-2*t)

or

$$f(t) = \left(\frac{3}{4}e^{-6t} + \frac{1}{4}e^{-2t}\right)$$

B.

$$F(s) = \frac{10(s+2)}{(s^2 + 4s + 5)}$$

Matlab code

ilaplace((s+3)*(s+6)/(s*(s^2+10*s+24)))

ans =

1/4*exp(-4*t)+3/4

or

$$f(t) = \left(\frac{3}{4} + \frac{1}{4}e^{-4t}\right)$$

$$f(t) = \left(\frac{3}{4} + \frac{1}{4}e^{-4t}\right)$$

Problem 12.17

Given the following functions $F(s)$ find $f(t)$

$$F(s) = \frac{10}{(s^2 + 2s + 2)}$$

$$F(s) = \frac{10(s+2)}{(s^2 + 4s + 5)}$$

Suggested Solution

A.

$$F(s) = \frac{10}{(s^2 + 2s + 2)}$$

$$F(s) = \frac{10}{s^2 + 2s + 2} = \frac{k_1}{s+1-\alpha} + \frac{k_1}{s+1+\alpha}$$

$$f(\alpha) = \frac{-5\alpha}{s+1-\alpha} + \frac{5\alpha}{s+1+\alpha}$$

$$f(\alpha) = 10e^{-t} \cos(t - 90^\circ)u(t)$$

$$f(\alpha) = 10e^{-t} \cos(t - 90^\circ)u(t)$$

B.

$$F(s) = \frac{10(s+2)}{(s^2 + 4s + 5)}$$

$$F(s) = \frac{10(s+2)}{s^2 + 4s + 5} = \frac{k_1}{s+2-\alpha} + \frac{k_1}{s+2+\alpha}$$

so

$$f(\alpha) = \frac{5}{s+2-\alpha} + \frac{5}{s+2+\alpha}$$

$$f(\alpha) = 10e^{-2t} \cos(t)u(t)$$

$$f(\alpha) = 10e^{-2t} \cos(t)u(t)$$

Problem 12.18

Given the following functions $F(s)$ find inverse Laplace functions.

$$F(s) = \frac{10}{(s^2 + 2s + 2)}$$

$$F(s) = \frac{10(s+2)}{(s^2 + 4s + 5)}$$

Suggested Solution

A

$$F(s) = \frac{10}{(s^2 + 2s + 2)}$$

$$F(s) = \frac{10(s+2)}{s^2 + 4s + 5} = \frac{k_1}{s+2-\alpha} + \frac{k_1}{s+2+\alpha}$$

for

$$s = -1 + \alpha$$

$$\frac{10(s+1)}{s+1+\alpha} = 5 = k_1$$

so

$$F(s) = \frac{5}{s+1-\alpha} + \frac{5}{s+1+\alpha}$$

$$f(t) = 10e^{-6} \cos tu(t)$$

$$f(t) = 10e^{-6} \cos tu(t)$$

B

$$F(s) = \frac{10(s+2)}{(s^2 + 4s + 5)}$$

$$F(s) = \frac{s+1}{s(s^2 + 4s + 5)} = \frac{k_1}{s} + \frac{k_2}{s+2-\alpha} + \frac{k_3}{s+2+\alpha}$$

for

$$s = 0$$

$$\frac{s+1}{s^2+4s+5} = 1/5 = k_1$$

for

$$s = -2 + \alpha$$

$$\frac{s+1}{s(s+2+\alpha)} = 0.31 \angle -108.43^\circ = k_2$$

$$F(s) = \frac{1/5}{s} + \frac{0.31 \angle -108.43^\circ}{s+2+\alpha} + \frac{0.31 \angle 108.43^\circ}{s+2+\alpha}$$

$$f(t) = \left(\frac{1}{5} + 0.62e^{-2t} \cos(t - 108.43^\circ) \right) u(t)$$

$$f(t) = \left(\frac{1}{5} + 0.62e^{-2t} \cos(t - 108.43^\circ) \right) u(t)$$

Problem 12.19

Given the following functions $F(s)$, find $f(t)$

$$F(s) = \frac{s(s+6)}{(s+3)(s^2+6s+18)}$$

$$F(s) = \frac{(s+4)(s+8)}{s(s^2+8s+32)}$$

Suggested Solution

A.

$$F(s) = \frac{s(s+6)}{(s+3)(s^2+6s+18)}$$

$$F(s) = \frac{s(s+6)}{(s+3)(s^2+6s+18)} = \frac{s(s+6)}{(s+3)(s+3+3\alpha)(s+3-3\alpha)}$$

$$= \frac{k_1}{s+3} + \frac{k_2}{s+3+3\alpha} + \frac{k_3}{s+3-3\alpha}$$

at

$$s = -3$$

$$\frac{s(s+6)}{(s+3)(s^2+6s+18)} = -1 = k_1$$

at

$$s = -3+3\alpha$$

$$\frac{s(s+6)}{(s+3)(s^2+6s+18)} = 1 = k_2$$

so

$$F(s) = \frac{-1}{s+3} + \frac{1}{s+3+3\alpha} + \frac{1}{s+3-3\alpha}$$

$$f(t) = (e^{-3t} + 2e^{-3t} \cos 3t)u(t)$$

$$f(t) = (e^{-3t} + 2e^{-3t} \cos 3t)u(t)$$

B.

$$F(s) = \frac{(s+4)(s+8)}{s(s^2+8s+32)}$$

$$F(s) = \frac{(s+4)(s+8)}{(s)(s^2+8s+32)} = \frac{s(s+6)}{(s+3)(s+3+3\alpha)(s+3-3\alpha)}$$

$$= \frac{k_1}{s} + \frac{k_2}{s+4+4\alpha} + \frac{k_2}{s+4-4\alpha}$$

at

$$s = 0$$

$$\frac{(s+4)(s+8)}{(s)(s^2+8s+32)} = 1 = k_1$$

at

$$s = -4 + 4\alpha$$

$$\frac{(s+4)(s+8)}{(s)(s^2+8s+32)} = \frac{-1}{2}\alpha = k_2$$

so

$$F(s) = \frac{1}{s} + \frac{1/2}{s+4+4\alpha} + \frac{\alpha/2}{s+4-4\alpha}$$

$$f(t) = (1 + e^{-4t} \cos(4t - 90^\circ))u(t)$$

$$f(t) = (1 + e^{-4t} \cos(4t - 90^\circ))u(t)$$

Problem 12.20

Given the following functions $F(s)$ find $f(t)$

$$F(s) = \frac{6s+12}{(s^2+4s+5)(s^2+4s+8)}$$

$$F(s) = \frac{s(s+2)}{s^2+2s+2}$$

Suggested Solution

$$\begin{aligned} F(s) &= \frac{6s+12}{((s+2)^2+1^2)((s+2)^2+2^2)} \\ &= \frac{k_1 \angle \theta_1}{s+2-j1} + \frac{k_1 \angle \theta_1}{s+2+j1} + \frac{k_2 \angle \theta_2}{s+2-j2} + \frac{k_2 \angle \theta_2}{s+2+j2} \end{aligned}$$

$$k_1 \angle \theta_1 = F(s)(s+2-j1) \Big|_{s=2+j1} = 1 \angle 0^\circ$$

$$k_1 \angle \theta_1 = F(s)(s+2-j2) \Big|_{s=2-j2} = -1 \angle 0^\circ$$

$$f(t) = [2e^{-2t} \cos(t) - 2e^{-2t} \cos(2t)]u(t)$$

$$f(t) = [2e^{-2t} \cos(t) - 2e^{-2t} \cos(2t)]u(t)$$

$$F(s) = \frac{s^2+2s+2-2}{(s^2+2s+2)} = 1 - \frac{2}{(s^2+2s+2)}$$

$$F(s) = 1 - \frac{2}{(s+1)^2 + (1)^2}$$

$$f(t) = [\delta(t) - 2e^{-t} \sin(t)]u(t)$$

$$f(t) = [\delta(t) - 2e^{-t} \sin(t)]u(t)$$

Problem 12.21

Use Matlab to solve Problem 12.19

Suggested Solution

$$F(s) = \frac{s(s+6)}{(s+3)(s^2+6s+18)}$$

Matlab Code

```
>> syms s t
>> ilaplace(s*(s+6)/((s+3)*(s^2+6*s+18)))
```

ans =

$$-e^{-3t} + 2e^{-3t} \cos(3t)$$

```
>>
```

$$f(t) = 2e^{-3t} \cos(3t) - e^{-3t}$$

$$f(t) = 2e^{-3t} \cos(3t) - e^{-3t}$$

$$F(s) = \frac{(s+3)(s+8)}{s(s^2+8s+32)}$$

Matlab Code

```
>> syms s t
>> ilaplace((s+4)*(s+8)/(s*(s^2+8*s+32)))
```

ans =

$$1 + e^{-4t} \sin(4t)$$

```
>>
```

$$f(t) = 1 + e^{-4t} \sin(4t)$$

$$f(t) = 1 + e^{-4t} \sin(4t)$$

Problem 12.22

Given following functions $F(s)$, find $f(t)$

$$F(s) = \frac{s+1}{s^2(s+2)}$$

$$F(s) = \frac{s+3}{(s+1)^2(s+4)}$$

Suggested Solution

A.

$$F(s) = \frac{s+1}{s^2(s+4)} = \frac{k_1}{s^2} + \frac{k_2}{s} + \frac{k_3}{s+4}$$

at

$$s = 0$$

$$\frac{s+1}{s+4} = k_1 = \frac{1}{4}$$

$$\frac{d}{ds} \left[\frac{s+1}{s+4} \right] = k_2 = -\frac{1}{16}$$

at

$$s = -4$$

$$\frac{s+1}{(s)^2} = k_3 = -\frac{1}{16}$$

so

$$F(s) = \frac{1/4}{s^2} + \frac{-1/16}{s} - \frac{1/16}{s+4}$$

$$f(t) = \left(\frac{1}{4} + \frac{1}{2}t - \frac{1}{4}e^{-4t} \right) u(t)$$

$$f(t) = \left(\frac{1}{4} + \frac{1}{2}t - \frac{1}{4}e^{-2t} \right) u(t)$$

B.

$$F(s) = \frac{(s+4)(s+8)}{s(s^2+8s+32)}$$

$$f(t) = 1 + e^{-4t} \sin(4t)$$

$$F(s) = \frac{s+3}{(s+1)^2(s+4)} = \frac{k_1}{(s+1)^2} + \frac{k_2}{s+1} + \frac{k_3}{s+4}$$

at

$$s = -1$$

$$\frac{s+3}{s+4} = k_1 = \frac{2}{3}$$

$$\frac{d}{ds} \left[\frac{s+3}{s+4} \right] = k_2 = \frac{1}{9}$$

at

$$s = -4$$

$$\frac{s+3}{(s+1)^2} = k_3 = \frac{1}{9}$$

so

$$F(s) = \frac{2/3}{(s+1)^2} + \frac{1/9}{s+1} - \frac{1/9}{s+4}$$

$$f(t) = \left(\frac{1}{9}e^{-t} + \frac{2}{3}te^{-t} - \frac{1}{9}e^{-4t} \right) u(t)$$

$$f(t) = \left(\frac{1}{9}e^{-t} + \frac{2}{3}te^{-t} - \frac{1}{9}e^{-4t} \right) u(t)$$

Problem 12.23

Given the following functions $F(s)$, find $f(t)$

$$F(s) = \frac{s+8}{s^2(s+6)}$$

$$F(s) = \frac{1}{s^2(s+1)^2}$$

Suggested Solution

A.

$$F(s) = \frac{s+8}{s^2(s+6)} = \frac{k_1}{s^2} + \frac{k_2}{s} + \frac{k_3}{s+6}$$

at

$$s = 0$$

$$\frac{s+8}{s+6} = k_1 = \frac{4}{3}$$

$$\frac{d}{ds} \left[\frac{s+8}{s+6} \right] = k_2 = \frac{-1}{18}$$

at

$$s = -6$$

$$\frac{s+8}{(s)^2} = k_3 = \frac{1}{18}$$

so

$$F(s) = \frac{4/3}{s^2} - \frac{1/18}{s} + \frac{1/18}{s+6}$$

$$f(t) = \left(\frac{4}{3}t - \frac{1}{18} + \frac{1}{18}e^{-6t} \right) u(t)$$

$$f(t) = \left(\frac{4}{3}t - \frac{1}{18} + \frac{1}{18}e^{-6t} \right) u(t)$$

B.

$$F(s) = \frac{s+8}{s^2(s+1)^2} = \frac{k_1}{s^2} + \frac{k_2}{s} + \frac{k_3}{(s+1)^2} + \frac{k_4}{s+1}$$

at

$$s = 0$$

$$\frac{1}{(s+1)^2} = k_1 = 1$$

$$\frac{d}{ds} \left[\frac{1}{(s+1)^2} \right] = k_2 = -2$$

at

$$s = -1$$

$$\frac{1}{(s)^2} = k_3 = \frac{1}{18}$$

$$\frac{d}{ds} \left[\frac{1}{(s)^2} \right] = k_4 = 1$$

so

$$F(s) = \frac{1}{s^2} - \frac{2}{s} - \frac{1}{(s+1)^2} + \frac{1}{s+1}$$

$$f(t) = (t-2+te^{-t}+2e^{-t})u(t)$$

$$f(t) = (t-2+te^{-t}+2e^{-t})u(t)$$

Problem 12.24

Given the following functions $F(s)$, find $f(t)$

$$F(s) = \frac{s+4}{(s+2)^2}$$

$$F(s) = \frac{s+6}{s(s+1)^2}$$

Suggested Solution

$$F(s) = \frac{s+4}{(s+2)^2} = \frac{k_1}{(s+2)^2} + \frac{k_2}{s+2}$$

at

$$s = -2$$

$$s+2 = 2 = k_1$$

$$\frac{d}{ds}[s+2] = k_2 = 1$$

$$f(t) = (2te^{-2t} + e^{-2t})u(t)$$

so

$$F(s) = \frac{2}{(s+2)^2} + \frac{1}{s+2}$$

$$f(t) = (2te^{-2t} + e^{-2t})u(t)$$

B.

$$F(s) = \frac{s+6}{s(s+1)^2} = \frac{k_1}{s} + \frac{k_2}{(s+1)^2} + \frac{k_3}{s+1}$$

at

$$s = 0$$

$$\frac{s+6}{(s+1)^2} = k_1 = 6$$

at

$$s = -1$$

$$\frac{s+6}{s} = k_2 = -5$$

$$\frac{d}{ds}\left[\frac{s+6}{s}\right] = k_3 = -6$$

so

$$F(s) = \frac{6}{s} - \frac{5}{(s+1)^2} - \frac{6}{s+1}$$

$$f(t) = (6 - 5te^{-t} - te^{-t})u(t)$$

Problem 12.25

Given the following functions $F(s)$ find $f(t)$

$$F(s) = \frac{s^2}{(s+1)^2(s+2)}$$

$$F(s) = \frac{s^2 + 9s - 20}{s(s+4)^3(s+5)}$$

Suggested Solution

A.

$$F(s) = \frac{s^2}{(s+1)^2(s+2)} = \frac{k_1}{(s+1)^2} + \frac{k_2}{s+1} + \frac{k_3}{s+2}$$

at

$$s = -1$$

$$\frac{s^2}{(s+2)} = k_1 = 1$$

at

$$s = -2$$

$$\frac{s^2}{(s+1)^2} = k_3 = 4$$

$$\frac{d}{ds} \left[\frac{s^2}{(s+1)^2} \right] = k_2 = -3$$

so

$$F(s) = \frac{1}{(s+1)^2} - \frac{3}{s+1} + \frac{4}{s+2}$$

$$f(t) = (te^{-t} - 3e^{-t} + 4te^{-2t})u(t)$$

$$f(t) = (te^{-t} - 3e^{-t} + 4te^{-2t})u(t)$$

B.

$$F(s) = \frac{s^2 + 9s - 20}{s(s+4)^3(s+5)} = \frac{1}{s(s+4)^2} = \frac{k_1}{s} + \frac{k_2}{(s+4)^2} + \frac{k_3}{s+4}$$

at

$$s = 0$$

$$\frac{1}{(s+4)^2} = k_1 = 1/16$$

at

$$s = -4$$

$$\frac{1}{s} = k_2 = -1/4$$

$$\frac{d}{ds} \left[\frac{1}{s} \right] = k_3 = -1/16$$

so

$$F(s) = \frac{1/16}{s} - \frac{1/4}{(s+4)^2} - \frac{1/16}{s+4}$$

$$f(t) = \left(\frac{1}{16} - \frac{t}{4} e^{-4t} - \frac{1}{16} e^{-4t} \right) u(t)$$

$$f(t) = \left(\frac{1}{16} - \frac{t}{4} e^{-4t} - \frac{1}{16} e^{-4t} \right) u(t)$$

Problem 12.26

Find $f(t)$ if $F(s)$ is given by expression

$$F(s) = \frac{s(s+1)}{(s+2)^3(s+3)}$$

Suggested Solution

$$F(s) = \frac{s(s+1)}{(s+2)^3(s+3)} = \frac{A}{s+3} + \frac{B}{(s+3)^2} + \frac{C}{(s+3)^3} + \frac{D}{s+2}$$

$$A = F(s)(s+3) \Big|_{s=-3} = -6$$

$$B = F(s)(s+2)^2 \Big|_{s=-2} = 2$$

$$F(0) = 0 = \frac{-6}{3} + \frac{2}{8} + \frac{C}{4} + \frac{D}{2} \Rightarrow C + 2D = 7$$

$$F(-1) = 0 = \frac{-6}{2} + 2 + C + D \Rightarrow C + D = 1$$

\therefore

$$D = 6, C = -5$$

$$F(s) = \frac{-6}{s+3} + \frac{2}{(s+3)^3} - \frac{5}{(s+3)^2} + \frac{6}{s+2}$$

$$f(t) = (t^2e^{-2t} - 5te^{-2t} + 6e^{-2t} - 6e^{-3t})u(t)$$

$$f(t) = (t^2e^{-2t} - 5te^{-2t} + 6e^{-2t} - 6e^{-3t})u(t)$$

Problem 12.27

Find $f(t)$ if $F(s)$ is given by

$$F(s) = \frac{12(s+2)}{s^2(s+1)(s^2+4s+8)}$$

Suggested Solution

$$F(s) = \frac{k_1}{s^2} + \frac{k_2}{s} + \frac{k_3}{s+1} + \frac{k_4}{s+2-2\alpha} + \frac{k_4}{s+2+2\alpha}$$

at

$$s = 0$$

$$\frac{12(s+2)}{(s+1)(s^2+4s+8)} = 3 = k_1$$

$$\frac{d}{ds} \left[\frac{12(s+2)}{(s+1)(s^2+4s+8)} \right] = k_2 = -3$$

at

$$s = -1$$

$$\frac{12(s+2)}{(s^2)(s^2+4s+8)} = k_3 = \frac{12}{5}$$

at

$$s = -2+2\alpha$$

$$\frac{12(s+2)}{s^2(s+1)} = k_4 = \frac{1}{3} \angle -26.56^\circ$$

so

$$F(s) = \frac{3}{s^2} - \frac{3}{s} + \frac{12/5}{s+1} + \frac{\frac{1}{3} \angle -26.56^\circ}{s+2-2\alpha} + \frac{\frac{1}{3} \angle 26.56^\circ}{s+2+2\alpha}$$

$$f(t) = \left[-3 + 3t + \frac{12}{5} e^{-t} + \frac{2}{3} e^{-2t} \cos(2t - 26.56^\circ) \right] u(t)$$

$$f(t) = \left[-3 + 3t + \frac{12}{5} e^{-t} + \frac{2}{3} e^{-2t} \cos(2t - 26.56^\circ) \right] u(t)$$

Problem 12.28

Use Matlab to solve Problem 12.25

Suggested Solution

$$F(s) = \frac{s^2}{(s+1)^2(s+2)}$$

Matlab Code

```
>> syms s t
>>
>> ilaplace(s^2/((s+1)^2*(s+2)))
```

ans =

$$(-3+t)*\exp(-t)+4*\exp(-2*t)$$

```
>>
```

$$f(t) = te^{-t} - 3e^{-t} + 4e^{-2t}$$

$$f(t) = te^{-t} - 3e^{-t} + 4e^{-2t}$$

$$F(s) = \frac{s^2 + 9s + 20}{s(s+4)^3(s+5)}$$

Matlab Code

```
>> syms s t
>> ilaplace((s^2+9*s+20)/(s*(s+4)^3*(s+5)))
```

ans =

$$-1/4*t*\exp(-4*t)-1/16*\exp(-4*t)+1/16$$

```
>>
```

$$f(t) = 0.0625\{1 - e^{-4t} - 4te^{-4t}\}$$

$$f(t) = 0.0625\{1 - e^{-4t} - 4te^{-4t}\}$$

Problem 12.29

Find the inverse Laplace transform of the following functions

$$F(s) = \frac{e^{-s}}{s+1}$$

$$F(s) = \frac{1-e^{-2s}}{s}$$

$$F(s) = \frac{1-e^{-s}}{s+2}$$

Suggested Solution

a.

$$F(s) = \frac{e^{-s}}{s+1}$$

let

$$G(s) = \frac{1}{s+1} \Rightarrow g(t) = e^{-t}u(t)$$

$$f(t) = g(t-1) \Rightarrow f(t) = e^{-(t-1)}u(t-1)$$

b.

$$F(s) = \frac{1-e^{-2s}}{s}$$

let

$$G(s) = \frac{1}{s} \Rightarrow g(t) = u(t)$$

$$f(t) = g(t) - g(t-2) \Rightarrow f(t) = u(t) - u(t-2)$$

c.

$$F(s) = \frac{1-e^{-s}}{s+2}$$

let

$$G(s) = \frac{1}{s+2} \Rightarrow g(t) = e^{-2t}u(t)$$

$$f(t) = g(t) - g(t-1) \Rightarrow f(t) = e^{-2t}u(t) - e^{-2(t-1)}u(t-1)$$

$$f(t) = e^{-(t-1)}u(t-1)$$

$$f(t) = u(t) - u(t-2)$$

$$f(t) = e^{-2t}u(t) - e^{-2(t-1)}u(t-1)$$

Problem 12.30

Find the inverse Laplace transform of the following function

$$F(s) = \frac{(s+1)e^{-s}}{s(s+2)}$$

$$F(s) = \frac{10e^{-2s}}{(s+1)(s+3)}$$

Suggested Solution

$$F(s) = \frac{(s+1)e^{-s}}{s(s+2)} = e^{-s} \left[\frac{k_1}{s} + \frac{k_2}{s+2} \right]$$

at

$$s = 0$$

$$\frac{s+1}{s+2} = k_1 = 1/2$$

at

$$s = -2$$

$$\frac{s+1}{s} = 1/2 = k_2$$

$$F(s) = e^{-s} \left[\frac{1/2}{s} + \frac{1/2}{s+2} \right]$$

$$f(t) = \frac{1}{2}u(t-1) + \frac{1}{2}e^{-2(t-1)}u(t-1)$$

$$F(s) = \frac{10e^{-2s}}{(s+1)(s+3)} = e^{-2s} \left[\frac{k_1}{s+1} + \frac{k_2}{s+3} \right]$$

at

$$s = -1$$

$$\frac{10}{s+3} = k_1 = 5$$

at

$$s = -3$$

$$\frac{10}{s+1} = k_2 = -5$$

$$F(s) = e^{-2s} \left[\frac{5}{s+1} - \frac{5}{s+3} \right]$$

$$f(t) = [5e^{-(t-2)} - 5e^{-3(t-2)}]u(t-2)$$

$$f(t) = \frac{1}{2}u(t-1) + \frac{1}{2}e^{-2(t-1)}u(t-1)$$

$$f(t) = [5e^{-(t-2)} - 5e^{-3(t-2)}]u(t-2)$$

Problem 12.31

Find the inverse Laplace transform $f(t)$ if $F(s)$ is

$$F(s) = \frac{se^{-s}}{(s+1)(s+2)}$$

Suggested Solution

$$F(s) = \frac{se^{-s}}{(s+1)(s+2)}$$

let

$$G(s) = \frac{s}{(s+1)(s+2)} = \frac{A}{s+1} + \frac{B}{s+2}$$

$$A = G(s)(s+1) \Big|_{s=-1} = -1$$

$$B = G(s)(s+2) \Big|_{s=-2} = 2$$

$$G(s) = \frac{2}{s+2} - \frac{1}{s+1} \Rightarrow g(t) = [2e^{-2t} - e^{-t}]u(t)$$

$$f(t) = g(t-1)$$

$$f(t) = [2e^{-2(t-1)} - e^{-(t-1)}]u(t-1)$$

$$f(t) = [2e^{-2(t-1)} - e^{-(t-1)}]u(t-1)$$

Problem 12.32

Find $f(t)$ if $F(s)$ is given by the following functions

$$F(s) = e^{-2s} \left[\frac{s^2 + 2s + 3}{s(s+1)(s+2)} \right] \qquad F(s) = \frac{(s+2)e^{-4s}}{s^2(s+1)}$$

Suggested Solution

A.

$$F(s) = e^{-2s} \left[\frac{s^2 + 2s + 3}{s(s+1)(s+2)} \right] = e^{-2s} \left[\frac{k_1}{s} + \frac{k_2}{s+1} + \frac{k_3}{s+2} \right]$$

at

$$s = 0$$

$$\frac{s^2 + 2s + 3}{(s+1)(s+2)} = k_1 = \frac{3}{2}$$

at

$$s = -1$$

$$\frac{s^2 + 2s + 3}{s(s+2)} = k_2 = -2$$

at

$$s = -2$$

$$\frac{s^2 + 2s + 3}{s(s+1)} = k_3 = \frac{3}{2}$$

so

$$F(s) = e^{-2s} \left[\frac{3/2}{s} + \frac{-2}{s+1} + \frac{3/2}{s+2} \right]$$

$$f(t) = \left[\frac{3}{2} - 2e^{-(t-2)} + \frac{3}{2}e^{-2(t-2)} \right] u(t-2)$$

B.

$$F(s) = \frac{(s+2)e^{-4s}}{s^2(s+1)} = e^{-4s} \left[\frac{k_1}{s^2} + \frac{k_2}{s} + \frac{k_3}{s+1} \right]$$

at

$$s = 0$$

$$\frac{s+2}{s+1} = k_1 = 2$$

$$\frac{d}{ds} \left[\frac{s+2}{s+1} \right] = -1 = k_2$$

at

$$s = -1$$

$$\frac{s+2}{s+1} = k_3 = 1$$

so

$$F(s) = e^{-4s} \left[\frac{2}{s^2} - \frac{1}{s} + \frac{1}{s+1} \right]$$

$$f(t) = [2(t-4) - 1 + e^{-(t-4)}] u(t-4)$$

$$f(t) = \left[\frac{3}{2} - 2e^{-(t-2)} + \frac{3}{2}e^{-2(t-2)} \right] u(t-2)$$

$$f(t) = [2(t-4) - 1 + e^{-(t-4)}] u(t-4)$$

Problem 12.33

Find $f(t)$ if $F(s)$ is given by following functions

$$F(s) = e^{-s} \left[\frac{2(s+1)}{(s+3)(s+2)} \right]$$

$$F(s) = \frac{10(s+2)e^{-2s}}{(s+4)(s+1)}$$

Suggested Solution

A.

$$F(s) = e^{-s} \left[\frac{2(s+1)}{(s+3)(s+2)} \right] = e^{-s} \left[\frac{k_1}{s+2} + \frac{k_2}{s+3} \right]$$

at

$$s = -2$$

$$\frac{2(s+1)}{(s+3)} = k_1 = -2$$

at

$$s = -3$$

$$\frac{2(s+1)}{(s+2)} = k_2 = 4$$

so

$$F(s) = e^{-2s} \left[\frac{-2}{s+2} + \frac{4}{s+3} \right]$$

$$f(t) = [-2e^{-(t-1)} + 4e^{-3(t-1)}]u(t-1)$$

B

$$F(s) = \frac{10(s+2)e^{-2s}}{(s+4)(s+1)} = e^{-2s} \left[\frac{k_1}{s+1} + \frac{k_2}{s+4} \right]$$

at

$$s = -1$$

$$\frac{10(s+2)}{(s+4)} = k_1 = \frac{10}{3}$$

at

$$s = -4$$

$$\frac{10(s+2)}{(s+1)} = k_2 = 4$$

so

$$F(s) = e^{-2s} \left[\frac{10/3}{s+1} + \frac{4}{s+4} \right]$$

$$f(t) = \left[\frac{10}{3}e^{-(t-2)} + \frac{20}{3}e^{-4(t-2)} \right]u(t-2)$$

$$f(t) = [-2e^{-(t-1)} + 4e^{-3(t-1)}]u(t-1)$$

$$f(t) = \left[\frac{10}{3} e^{-(t-2)} + \frac{20}{3} e^{-4(t-2)} \right] u(t-2)$$

Problem 12.34

Solve the following differential equations using Laplace Transform

$$\frac{dx(t)}{dt} + 3x(t) = e^{-2t}$$

$$\frac{dx(t)}{dt} + 3x(t) = 2u(t)$$

Suggested Solution

A.

$$\frac{dx(t)}{dt} + 3x(t) = e^{-2t}, x(0) = 1$$

$$\frac{dx(t)}{dt} \Leftrightarrow sX(s) - x(0) = \frac{1}{s+2} \Rightarrow X(s)(s+3) = \frac{1}{s+2} + 1 = \frac{s+3}{s+2}$$

$$X(s) = \frac{1}{s+2} \Rightarrow x(t) = e^{-2t}u(t)$$

B.

$$\frac{dx(t)}{dt} + 3x(t) = 2u(t), x(0) = 2$$

$$\frac{dx(t)}{dt} \Leftrightarrow sX(s) - 2 + 3X(s) \Rightarrow X(s)(s+3) = \frac{2}{s} + 2 = \frac{2(s+1)}{s}$$

$$x(t) = \frac{2}{3}[1 + 2e^{-3t}]u(t)$$

$$x(t) = e^{-2t}u(t)$$

$$x(t) = \frac{2}{3}[1 + 2e^{-3t}]u(t)$$

Problem 12.35

Solve the following differential equations using Laplace transform

A. $\frac{d^2y(t)}{dt^2} + \frac{2dy(t)}{dt} + y(t) = e^{-2t}, y(0) = y'(0) = 0$

B. $\frac{d^2y(t)}{dt^2} + \frac{4dy(t)}{dt} + 4y(t) = u(t), y(0) = 0; y'(0) = 1$

Suggested Solution

A.

$$\frac{d^2y(t)}{dt^2} + \frac{2dy(t)}{dt} + y(t) = e^{-2t}, y(0) = y'(0) = 0$$

$$s^2Y(s) + 2sY(s) + Y(s) = Y(s)[s^2 + 2s + 1] = \frac{1}{s+2}$$

$$Y(s) = \frac{1}{(s+1)^2(s+2)} = \frac{A}{(s+1)^2} + \frac{B}{s+1} + \frac{C}{s+2}; C = Y(s)(s+2)|_{s=-2} = 1$$

$$A = Y(s)(s+1)^2|_{s=-1} = 1$$

$$Y(0) = \frac{1}{2} = 1 + B + \frac{1}{2} \Rightarrow B = -1$$

$$Y(s) = \frac{1}{(s+1)^2} - \frac{1}{s+1} + \frac{1}{s+2}$$

$$y(t) = (te^{-t} - e^{-t} + e^{-2t})u(t)$$

B.

$$\frac{d^2y(t)}{dt^2} + \frac{4dy(t)}{dt} + 4y(t) = u(t), y(0) = 0; y'(0) = 1$$

$$s^2Y(s) - sy'(0) - y(0) + 4sY(s) - 4y(0) + 4Y(s) = \frac{1}{s}$$

$$Y(s)[s^2 + 4s + 4] = \frac{1}{s} + s = \frac{s^2 + 1}{s}$$

$$Y(s) = \frac{s^2 + 1}{s(s+2)^2} = \frac{A}{s} + \frac{B}{(s+2)^2} + \frac{C}{s+2}$$

$$A = Y(s)s|_{s=0} = \frac{1}{4}$$

$$B = Y(s)(s+2)^2|_{s=-2} = -2.5$$

$$Y(-1) = -2 = -\frac{1}{4} - \frac{5}{2} + C \Rightarrow C = \frac{3}{4}$$

$$Y(s) = \frac{1}{4} \left[\frac{1}{s} - \frac{10}{(s+2)^2} + \frac{3}{s+2} \right]$$

$$y(t) = \frac{1}{4} [1 - 10te^{-2t} + 3e^{-2t}]u(t)$$

$$y(t) = (te^{-t} - e^{-t} + e^{-2t})u(t)$$

$$y(t) = \frac{1}{4}[1 - 10te^{-2t} + 3e^{-2t}]u(t)$$

Problem 12.36

Use Laplace transform to find $y(t)$ if

$$\frac{dy(t)}{dt} + 5y(t) + 4 \int_0^t y(x) dx = u(t), y(0) = 0, t > 0$$

Suggested Solution

In Laplace terms

$$sY(s) + 5Y(s) + \frac{4}{s}Y(s) = \frac{1}{s}$$

$$Y(s)[s^2 + 5s + 4] = 1$$

so

$$Y(s) = \frac{1}{s^2 + 5s + 4} = \frac{1}{(s+1)(s+4)} = \frac{k_1}{s+1} + \frac{k_2}{s+4} \Rightarrow k_1 = 1/3; k_2 = -1/3$$

so

$$Y(s) = \frac{1/3}{s+1} - \frac{1/3}{s+4}$$

$$y(t) = \left[\frac{1}{3}e^{-t} - \frac{1}{3}e^{-4t} \right] u(t)$$

$$y(t) = \left[\frac{1}{3}e^{-t} - \frac{1}{3}e^{-4t} \right] u(t)$$

Problem 12.37

Solve the integrodifferential equations using Laplace transforms.

$$\frac{dy(t)}{dt} + 2y(t) + \int_0^t y(\lambda) d\lambda = 1 - e^{-2t}, y(0) = 0, t > 0$$

Suggested Solution

In Laplace terms

$$sY(s) + 2Y(s) + \frac{1}{s}Y(s) = \frac{1}{s} - \frac{1}{s+2}$$

$$Y(s)\left[s + 2 + \frac{1}{s}\right] = \frac{1}{s} - \frac{1}{s+2}$$

so

$$Y(s) = \frac{k_1}{(s+1)^2} + \frac{k_2}{s+1} + \frac{k_3}{s+2} \Rightarrow$$

at

$$s = -1$$

$$\frac{2}{s+2} = 2 = k_1$$

$$\frac{d}{ds} \left[\frac{2}{s+2} \right] = -2 = k_2$$

at

$$s = -2$$

$$\frac{2}{(s+1)^2} = 2 = k_3$$

so

$$F(s) = \frac{2}{(s+1)^2} - \frac{2}{s+1} + \frac{2}{s+2}$$

$$f(t) = [2te^{-t} - 2e^{-t} + 2e^{-2t}]u(t)$$

$$f(t) = [2te^{-t} - 2e^{-t} + 2e^{-2t}]u(t)$$

Problem 12.38

Determine the $y(t)$ in the following equation if all initial conditions are zero.

$$\frac{d^3 y(t)}{dt^3} + 4 \frac{d^2 y(t)}{dt^2} + 3 \frac{dy(t)}{dt} = 10e^{-2t}$$

Suggested Solution

$$\frac{d^3 y(t)}{dt^3} + 4 \frac{d^2 y(t)}{dt^2} + 3 \frac{dy(t)}{dt} = 10e^{-2t}$$

All initial conditions are zero.

$$s^3 Y(s) + 4s^2 Y(s) + 3s Y(s) = \frac{10}{s+2}$$

$$Y(s) = \frac{10}{s(s+2)(s+1)(s+3)} = \frac{A}{s} + \frac{B}{s+2} + \frac{C}{s+1} + \frac{D}{s+3}$$

$$A = Y(s)s \Big|_{s=0} = 5/3$$

$$B = Y(s)(s+2) \Big|_{s=-2} = 5$$

$$C = Y(s)(s+1) \Big|_{s=-1} = -5$$

$$D = Y(s)(s+3) \Big|_{s=-3} = -5/3$$

$$Y(s) = \frac{5/3}{s} + \frac{5}{s+2} - \frac{5}{s+1} - \frac{5/3}{s+3}$$

$$y(t) = \left(\frac{5}{3} + 5e^{-2t} - 5e^{-t} - \frac{5}{3}e^{-3t} \right) u(t)$$

$$y(t) = \left(\frac{5}{3} + 5e^{-2t} - 5e^{-t} - \frac{5}{3}e^{-3t} \right) u(t)$$

Problem 12.39

Find $f(t)$ using convolution if $F(s)$ is

$$F(s) = \frac{1}{(s+1)(s+2)}$$

Suggested Solution

$$F(s) = \frac{1}{(s+1)(s+2)}$$

let

$$F_1(s) = \frac{1}{s+1}$$

$$F_2(s) = \frac{1}{s+2}$$

$$f_1(t) = e^{-t}u(t)$$

$$f_2(t) = e^{-2t}u(t)$$

$$f(t) = \int_0^t e^{-(t-\lambda)} e^{-2\lambda} d\lambda = e^{-t} \int_0^t e^{-\lambda} d\lambda = e^{-t} [e^{-\lambda}]_t^0$$

$$f(t) = e^{-t} [1 - e^{-t}]$$

$$f(t) = (e^{-t} - e^{-2t})u(t)$$

$$f(t) = (e^{-t} - e^{-2t})u(t)$$

Problem 12.40

Use convolution to find $f(t)$ if

$$F(s) = \frac{1}{(s+1)(s+2)^2}$$

Suggested Solution

$$F(s) = \frac{1}{(s+1)(s+2)^2}$$

let

$$F_1(s) = \frac{1}{(s+2)^2}$$

$$F_2(s) = \frac{1}{s+1}$$

$$f_1(t) = te^{-2t}u(t)$$

$$f_2(t) = e^{-t}u(t)$$

$$f(t) = \int_0^t e^{-(t-\lambda)} \lambda e^{-2\lambda} d\lambda = e^{-t} \int_0^t \lambda e^{-\lambda} d\lambda = e^{-t} [-e^{-\lambda} - \lambda e^{-\lambda}]_0^t$$

$$f(t) = e^{-t} [-e^{-t} - te^{-t} + 1]$$

$$f(t) = (e^{-t} - te^{-2t} - e^{-2t})u(t)$$

$$f(t) = (e^{-t} - te^{-2t} - e^{-2t})u(t)$$

Problem 12.41

Determine the initial and final value of $F(s)$ given by the expression

$$F(s) = \frac{2(s+2)}{s(s+1)}$$

$$F(s) = \frac{2(s^2 + 2s + 6)}{s(s+1)}$$

$$F(s) = \frac{2s^2}{s(s+1)(s^2 + 2s + 2)}$$

Suggested Solution

A.

$$F(s) = \frac{2(s+2)}{s(s+1)}$$

for

$$t = 0^+, \lim_{s \rightarrow \infty} sf(s) = \lim_{s \rightarrow \infty} \left[\frac{2(s+2)}{s(s+1)} \right] = \boxed{2}$$

$$t \rightarrow \infty, \lim_{s \rightarrow 0} sf(s) = \lim_{s \rightarrow 0} \left[\frac{2(s+2)}{s(s+1)} \right] = \boxed{4}$$

B.

$$F(s) = \frac{2(s^2 + 2s + 6)}{s(s+1)}$$

for

$$t = 0^+, \lim_{s \rightarrow \infty} sf(s) = \lim_{s \rightarrow \infty} \left[\frac{2(s^2 + 2s + 6)}{s(s+1)} \right] = \boxed{2}$$

$$t \rightarrow \infty, \lim_{s \rightarrow 0} sf(s) = \lim_{s \rightarrow 0} \left[\frac{2(s^2 + 2s + 6)}{s(s+1)} \right] = \boxed{0}$$

C.

$$F(s) = \frac{2s^2}{s(s+1)(s^2 + 2s + 2)}$$

for

$$t = 0^+, \lim_{s \rightarrow \infty} sf(s) = \lim_{s \rightarrow \infty} \left[\frac{2s^2}{s(s+1)(s^2 + 2s + 2)} \right] = \boxed{2}$$

$$t \rightarrow \infty, \lim_{s \rightarrow 0} sf(s) = \lim_{s \rightarrow 0} \left[\frac{2s^2}{s(s+1)(s^2 + 2s + 2)} \right] = \boxed{0}$$

Problem 12.42

Find the initial and final value of the time function $f(t)$ if $F(s)$ is given as

$$F(s) = \frac{10(s+2)}{(s+1)(s+3)}$$

$$F(s) = \frac{(s^2 + 2s + 4)}{(s+1)(s^3 + 4s^2 + 8s + 10)}$$

$$F(s) = \frac{2s}{(s^2 + 2s + 2)}$$

Suggested Solution

A.

$$F(s) = \frac{10(s+2)}{(s+1)(s+3)}$$

for

$$t = 0^+, \lim_{s \rightarrow \infty} sf(s) = \lim_{s \rightarrow \infty} \left[\frac{10(s+2)}{(s+1)(s+3)} \right] = \boxed{10}$$

$$t \rightarrow \infty, \lim_{s \rightarrow 0} sf(s) = \lim_{s \rightarrow 0} \left[\frac{10(s+2)}{(s+1)(s+3)} \right] = \boxed{0}$$

B.

$$F(s) = \frac{(s^2 + 2s + 4)}{(s+1)(s^3 + 4s^2 + 8s + 10)}$$

for

$$t = 0^+, \lim_{s \rightarrow \infty} sf(s) = \lim_{s \rightarrow \infty} \left[\frac{(s^2 + 2s + 4)}{(s+1)(s^3 + 4s^2 + 8s + 10)} \right] = \boxed{0}$$

$$t \rightarrow \infty, \lim_{s \rightarrow 0} sf(s) = \lim_{s \rightarrow 0} \left[\frac{(s^2 + 2s + 4)}{(s+1)(s^3 + 4s^2 + 8s + 10)} \right] = \boxed{0}$$

C.

$$F(s) = \frac{2s}{(s^2 + 2s + 2)}$$

for

$$t = 0^+, \lim_{s \rightarrow \infty} sf(s) = \lim_{s \rightarrow \infty} \left[\frac{2s^2}{s(s+1)(s^2 + 2s + 2)} \right] = \boxed{2}$$

$$t \rightarrow \infty, \lim_{s \rightarrow 0} sf(s) = \lim_{s \rightarrow 0} \left[\frac{2s^2}{s(s+1)(s^2 + 2s + 2)} \right] = \boxed{0}$$

Problem 12.43

Find the final values of the time function $f(t)$ if $F(s)$ is given as

$$F(s) = \frac{10(s+1)}{(s+2)(s+3)}$$

$$F(s) = \frac{10}{s^2 + 4s + 4}$$

Suggested Solution

A.

$$F(s) = \frac{10(s+1)}{(s+2)(s+3)}$$

for

$$t = 0^+, \lim_{s \rightarrow \infty} sf(s) = \lim_{s \rightarrow \infty} \left[\frac{10(s+1)}{(s+2)(s+3)} \right] = \boxed{10}$$

$$t \rightarrow \infty, \lim_{s \rightarrow 0} sf(s) = \lim_{s \rightarrow 0} \left[\frac{10(s+1)}{(s+2)(s+3)} \right] = \boxed{0}$$

B.

$$F(s) = \frac{10}{s^2 + 4s + 4}$$

for

$$t = 0^+, \lim_{s \rightarrow \infty} sf(s) = \lim_{s \rightarrow \infty} \left[\frac{10}{s^2 + 4s + 4} \right] = \boxed{0}$$

$$t \rightarrow \infty, \lim_{s \rightarrow 0} sf(s) = \lim_{s \rightarrow 0} \left[\frac{10}{s^2 + 4s + 4} \right] = \boxed{0}$$

Problem 12.44

In the network in fig, the switch opens at $t=0$. Use laplace transform to find $I(t)$ for $t>0$.

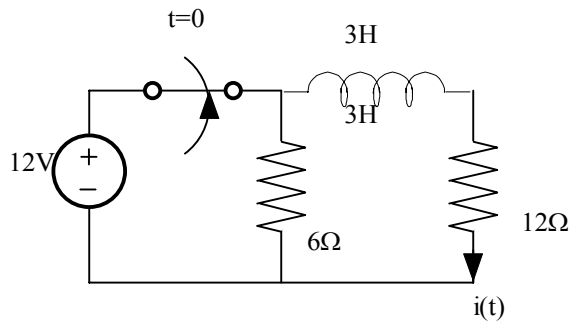

Suggested Solution

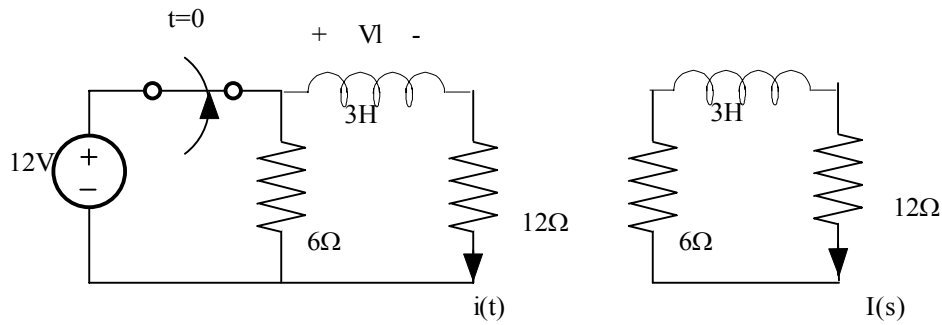

for

$t < 0$

$$V_L = 0V$$

and

$$i(0^-) = i(0^+) = 1A$$

$$18I(s) + 3sI(s) - 3i(0) = 0$$

$$I(s)[3s + 18] = 3$$

$$I(s) = \frac{1}{s + 6}$$

$$i(t) = e^{-6t}u(t)$$

$$i(t) = e^{-6t}u(t)$$

Problem 12.45

The switch in the circuit opens at $t=0$. Find $I(t)$ for $t>0$ using Laplace transforms.

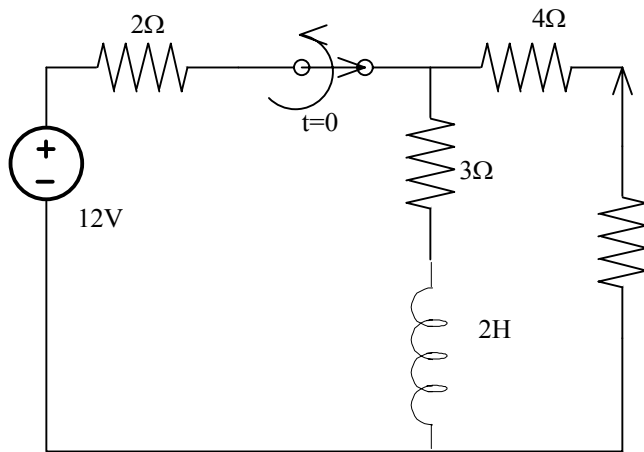

Suggested Solution

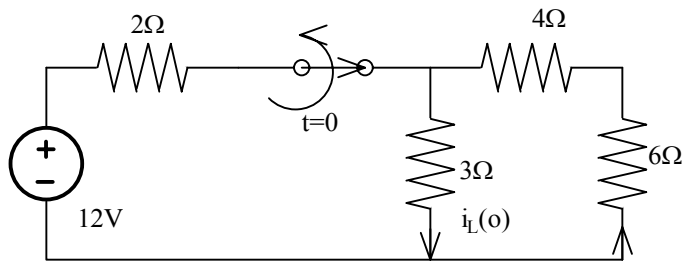
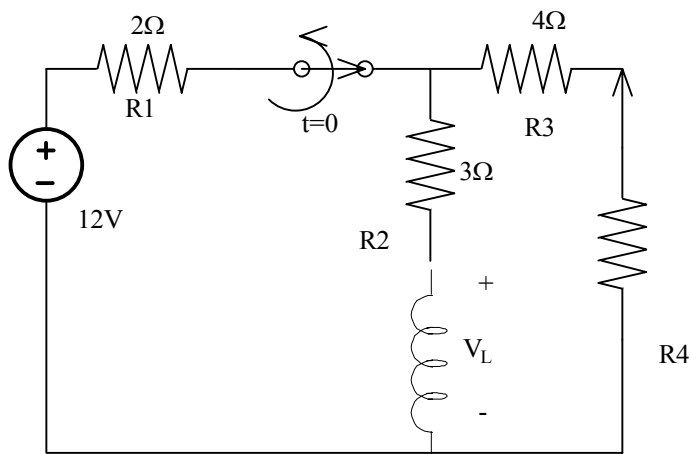

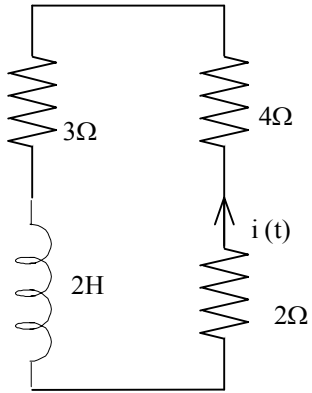

$$3i(t) + 4i(t) + 2i(t) + 2 \frac{di(t)}{dt} = 0$$

$$9I(s) + 2I(s) - 2i(0^+) = 0$$

$$I(s) = \left[s + \frac{9}{2} \right] = 4$$

$$I(s) = \frac{4}{s + \frac{9}{2}}$$

$$i(t) = 4e^{-\frac{9}{2}t} u(t) A$$

$$i(t) = 4e^{-\frac{9}{2}t} u(t) A$$

Problem 12.46

In the circuit in fig, the switch moves from position 1 to 2 at $t = 0$. Use Laplace transforms to find $v(t)$ for $t > 0$.

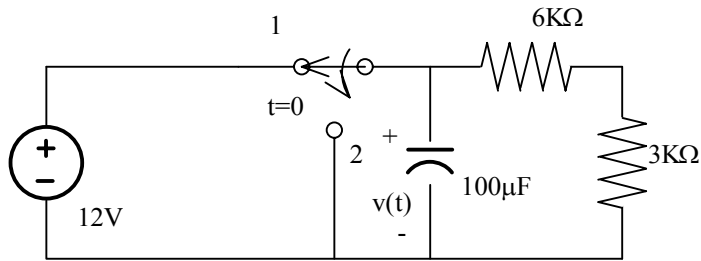

Suggested Solution

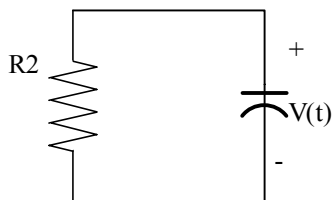
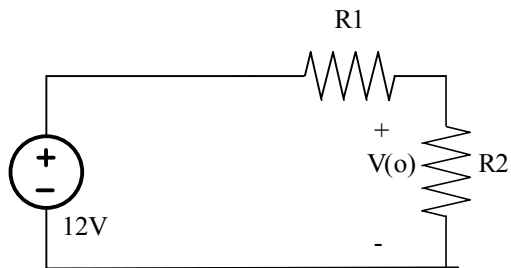
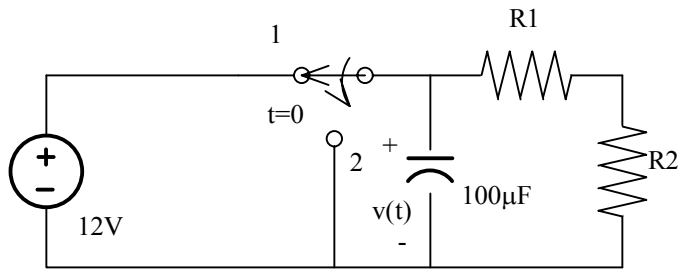

$$\frac{V(t)}{R} + \frac{Cdv(t)}{dt} = 0$$

$$\frac{V(s)}{R} + CV(s) - Cv(0) = 0$$

$$V(s)\left[s + \frac{1}{RC}\right] = v(0) \Rightarrow V(s) = \frac{4}{s+5}$$

$$v(t) = 4e^{-5t}u(t)V$$

$$v(t) = 4e^{-5t}u(t)V$$

Problem 12.47

In the network the switch closes at $t=0$. Use Laplace transforms to find $V_c(t)$ for $t > 0$.

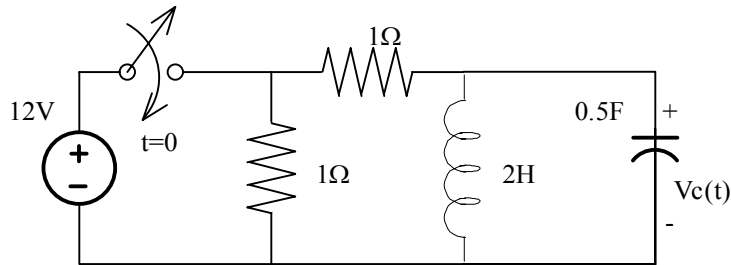

Suggested Solution

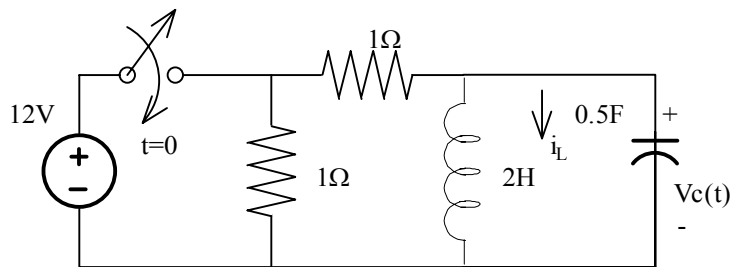

$$12 - V_c(t) = \frac{1}{L} \int_0^t V_c(x) dx + C \frac{dV_c(t)}{dt}$$

$$\frac{12}{s} - V_c(s) = \frac{1}{2s} V_c(s) + \frac{s}{2} V_c(s)$$

$$\frac{12}{s} = V_c(s) \left[1 + \frac{1}{2s} + \frac{s}{2} \right]$$

$$\frac{12}{s} = V_c(s) \left[\frac{2s+1+s^2}{2s} \right]$$

$$V_c(s) = \frac{24}{2s+1+s^2} = \frac{24}{(s+1)^2}$$

$$\therefore V_c(t) = 24te^{-t}u(t)V$$

$$\therefore V_c(t) = 24te^{-t}u(t)V$$

Problem 12.48

In the network the switch opens at $t=0$. Use Laplace transforms to find $i_L(t)$ for $t>0$.

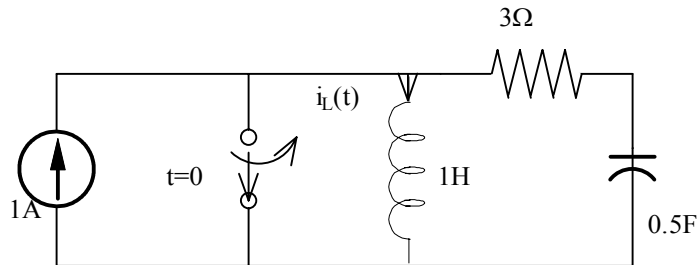

Suggested Solution

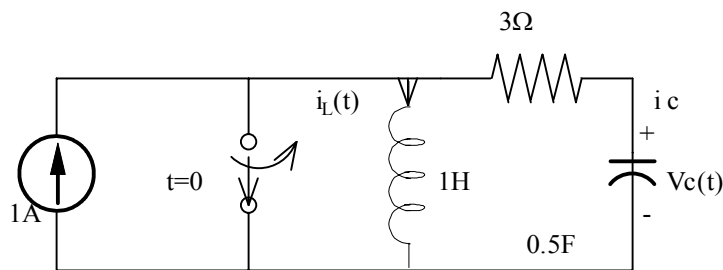

For $t > 0$

$$L \frac{di_L}{dt} = 3i_C + \frac{1}{C} \int_0^t i_C(t) dt$$

and

$$i_L + i_C = 1 \Rightarrow i_C = 1 - i_L$$

now,

$$sI_L(s) = 3 - 3I_L(s) + 2\left(\frac{1 - I_L(s)}{s}\right)$$

$$I_L(s)\left[s + \frac{2}{s}\right] = 3 + \frac{2}{s}$$

$$I_L(s) = \frac{3s + 2}{s^2 + 3s + 2} = \frac{A}{s + 2} + \frac{B}{s + 1} \Rightarrow A = 4, B = -1$$

$$I_L(s) = \frac{4}{s + 2} - \frac{1}{s + 1}$$

$$i_L(t) = (4e^{-2t} - e^{-t})u(t)$$

$$i_L(t) = (4e^{-2t} - e^{-t})u(t)$$

Problem 12.49

In the network the switch opens at $t=0$. Use Laplace transforms to find $V_0(t)$ for $t > 0$.

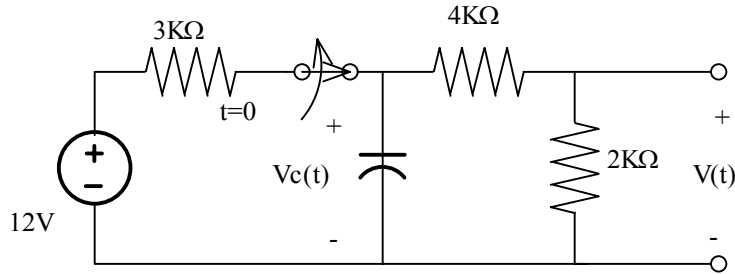

Suggested Solution

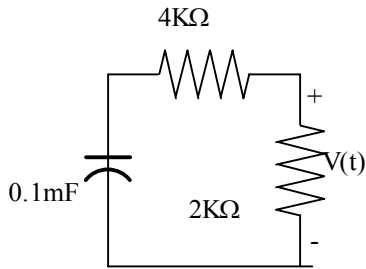
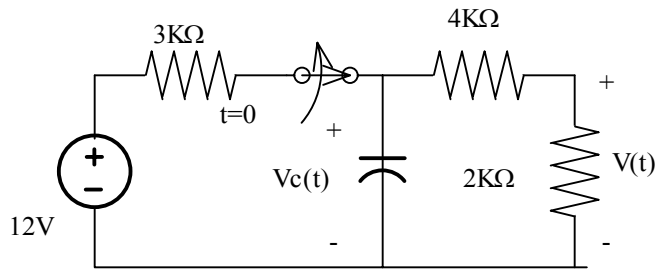

$$V_c(0^-) = 12 \left(\frac{2+4}{2+4+3} \right) = 8\text{V} = V_c(0^+)$$

$$v_0(0^+) = v_c(0^+) = \frac{8}{3}\text{V}$$

$$6ki(t) + \frac{1}{0.1\text{m}} \int_0^t i(t) dt - v_c(0) = 0$$

$$0.6I(s) + \frac{I(s)}{s} - \frac{0.8\text{m}}{s} = 0$$

$$I(s) = \frac{0.8}{0.6s+1} \text{mA} = \frac{4/3}{s + \frac{1}{0.6}}$$

$$i(t) = \frac{4}{3} e^{-t/0.6} u(t) \text{mA}$$

$$V_0(t) = 2ki(t) = \frac{8}{3} e^{-t/0.6} \text{V}$$

$$i(t) = \frac{4}{3} e^{-t/0.6} u(t) \text{ mA}$$

Problem 12FE-1

The output function of a network is expressed using Laplace transforms in the following form.

$$V_0(s) = \frac{12}{s(s+1)(s+2)}$$

Find the output as a function of time $v_0(t)$.

Suggested Solution

$$V_0(s) = \frac{12}{s(s+1)(s+2)} = \frac{A}{s} + \frac{B}{s+1} + \frac{C}{s+2}$$

$$\frac{12}{(s+1)(s+2)} \Big|_{s=0} = A = 6$$

$$\frac{12}{s(s+2)} \Big|_{s=-1} = B = -12$$

$$\frac{12}{s(s+1)} \Big|_{s=-2} = C = 6$$

$$V_0(t) = (6 - 12e^{-t} + 6e^{-2t})u(t)V$$

$$V_0(t) = (6 - 12e^{-t} + 6e^{-2t})u(t)V$$

Problem 12FE-2

The Laplace transform function representing the output voltage of a network is expressed as

$$V_0(s) = \frac{120}{s(s+10)(s+20)}$$

Determine the time domain function and the value of the $v_0(t)$ at $t=100\text{mSec}$.

Suggested Solution

$$V_0(s) = \frac{120}{s(s+10)(s+20)} = \frac{A}{s} + \frac{B}{s+10} + \frac{C}{s+20}$$

$$\frac{120}{(s+10)(s+20)} \Big|_{s=0} = A = 0.6$$

$$\frac{120}{s(s+20)} \Big|_{s=-10} = B = -1.2$$

$$\frac{120}{s(s+10)} \Big|_{s=-20} = C = 0.6$$

$$V_0(t) = (0.6 - 1.2e^{-10t} + 0.6e^{-20t})u(t)V$$

$$V_0(t) \Big|_{t=0.1\text{sec}} = 0.24V$$

$$V_0(t) \Big|_{t=0.1\text{sec}} = 0.24V$$

Problem 12FE-3

The Laplace transform function for the output voltage of a network is expressed in the following form

$$V_0(s) = \frac{12(s+2)}{s(s+1)(s+3)(s+4)}$$

Determine the final value i.e. $v_o(t)$ as $t \rightarrow \infty$, of this voltage.

Suggested Solution

$$V_0(s) = \frac{12(s+2)}{s(s+1)(s+3)(s+4)}$$

and

$$V_0(\infty) = sV_0(s)$$

$$V_0(\infty) = \frac{12(s+2)}{s(s+1)(s+3)(s+4)} \Big|_{s=0} = 2\text{v}$$

$$V_0 = 2\text{v}$$

Problem 13.1

Find the input impedance $Z(s)$ of the network in fig 3.1.

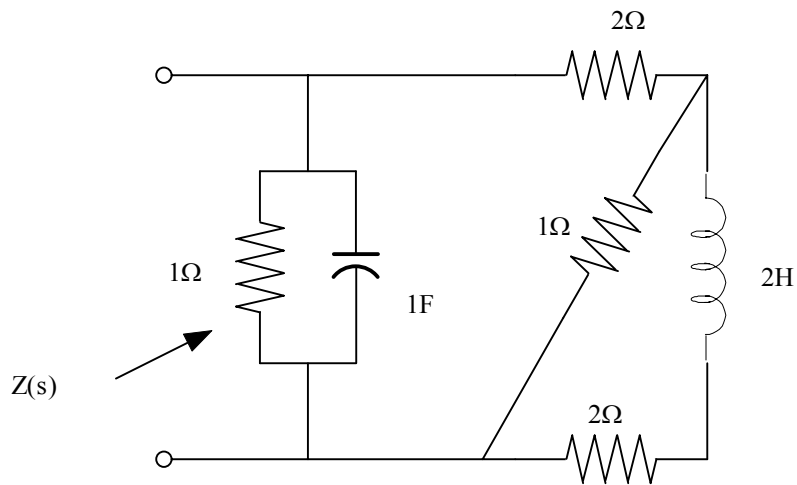

Suggested Solution

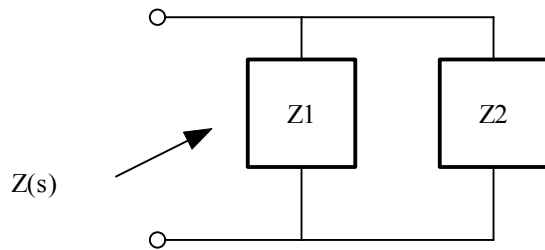

$$Z_1(s) = \frac{1\left(\frac{1}{s}\right)}{1 + \left(\frac{1}{s}\right)} = \frac{1}{s+1}$$

$$Z_2(s) = \frac{6s+8}{2s+3}$$

$$Z(s) = \frac{Z_1 Z_2}{Z_1 + Z_2} = \frac{6s+8}{6s^2 + 16s + 11}$$

Problem 13.2

Find the input impedance $Z(s)$ of the network in fig 3.2

(a). when the terminals B-B' are open circuited and (b). when the terminals B-B' are closed circuited.

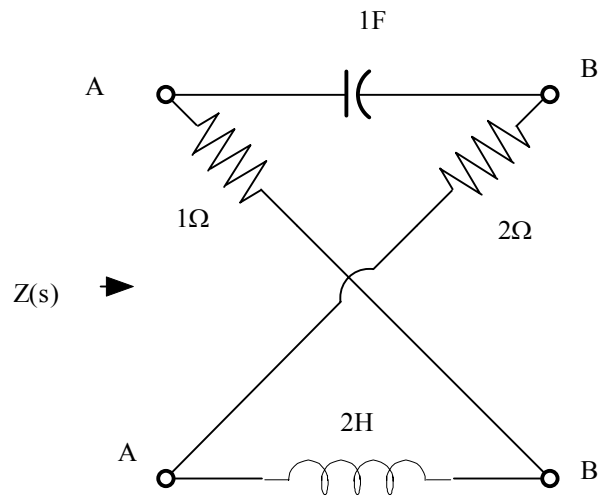

Suggested Solution

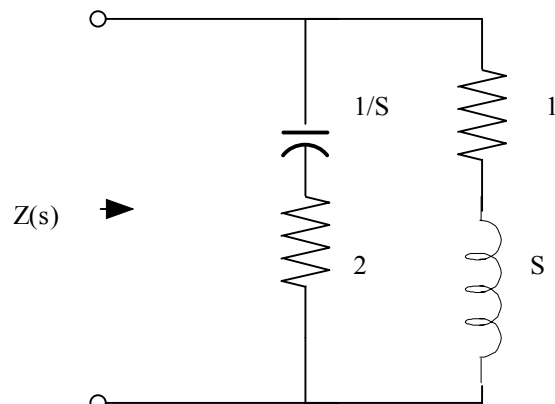

$$Z(S) = \frac{2S+1}{S+1}$$

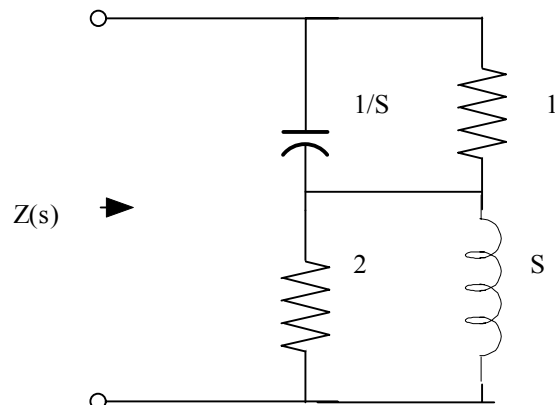

$$Z(S) = \frac{2S+1}{S+1}$$

Problem 13.3

Use laplace transforms to find $v(t)$ for $t > 0$ in the network shown in fig. Assume zero initial conditions.

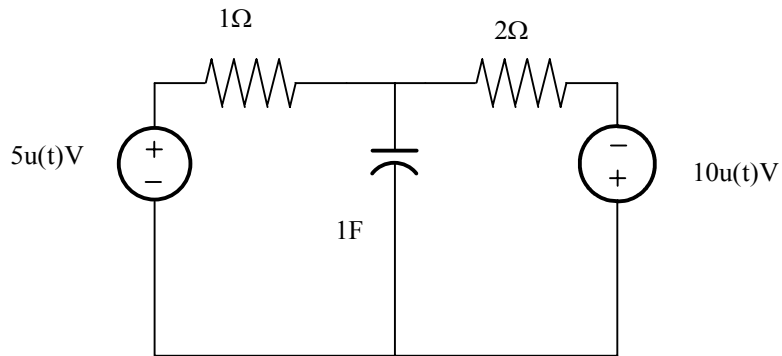

Suggested Solution

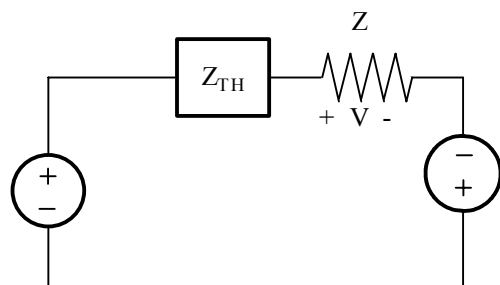
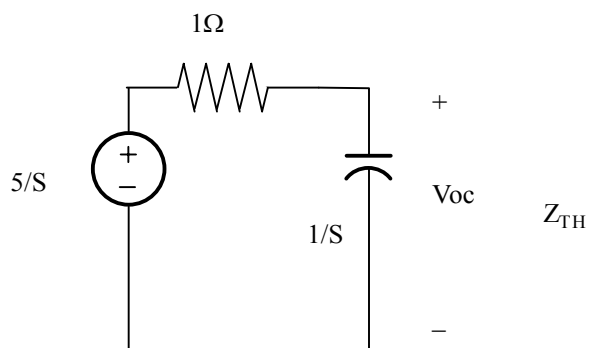
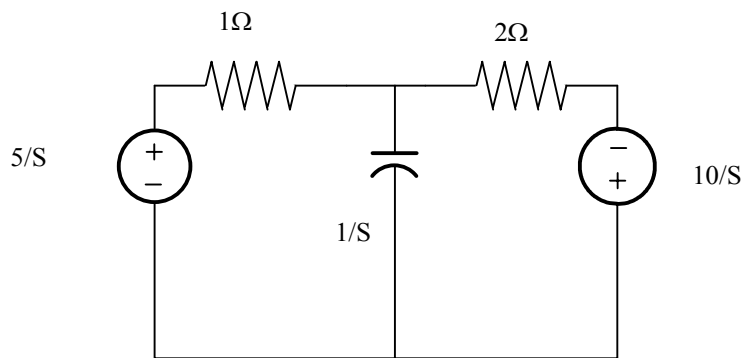

$$V_{oc} = \frac{5}{S} \left[\frac{1/S}{1+1/S} \right] = \frac{5}{S} \left[\frac{1}{1+S} \right]$$

$$Z_{TH} = 1 \parallel (1/S) = \frac{1}{1+S}$$

$$V_s = \left(V_{oc} + \frac{10}{S} \right) \left(\frac{2}{2+Z_{TH}} \right) = \frac{10}{S} \left[\frac{2S+3}{1+S} \right] \left[\frac{S+1}{3+2S} \right]$$

$$V_s = 10$$

$$V(t) = 10u(t)V$$

Problem 13.4

Use lap lace transforms and node analysis to find $i_1(t)$ for $t > 0$ in the network shown in fig. Assume zero initial conditions.

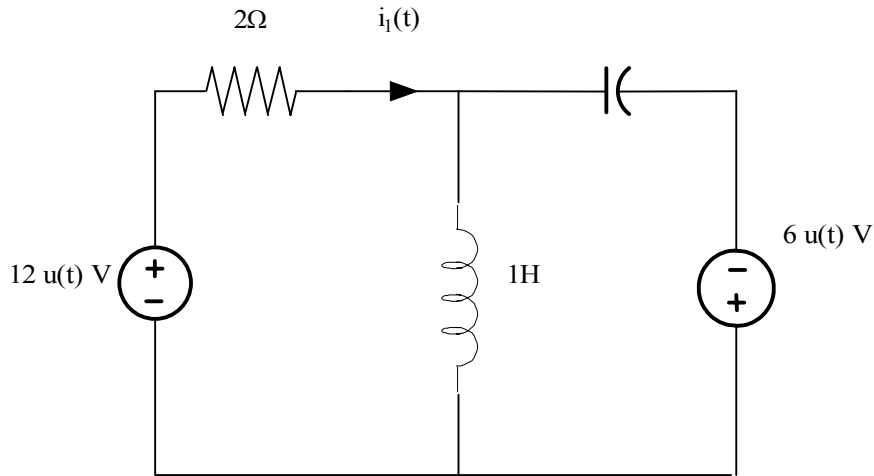

Suggested Solution

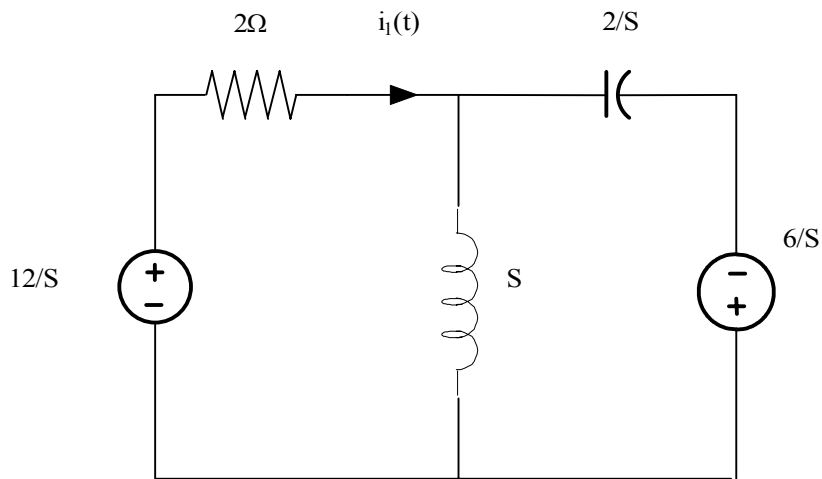

$$Z_{TH} = S \parallel (2/S) = \frac{2S}{2+S^2} \qquad V_{oc} = \frac{6}{S} \left[\frac{S}{1+2/S} \right] = \left[\frac{6}{2+S^2} \right]$$

$$I_1 = \frac{\frac{12}{S} + V_{oc}}{Z + Z_{TH}} = \frac{\frac{12}{S} + \left[\frac{6}{2+S^2} \right]}{2 + \frac{2S}{2+S^2}} = \frac{9S^2 + 12}{S(S^2 + S + 2)}$$

$$I_1 = \frac{A}{S} + \frac{K|\theta}{S - \frac{1}{2} - j\frac{\sqrt{7}}{2}} + \frac{K|-\theta}{S - \frac{1}{2} + j\frac{\sqrt{7}}{2}}$$

$$i_1(t) = \left[6 + 16.12e^{-t/2} \cos(\sqrt{7}t/2 + 26.37^\circ) \right] u(t) \text{ V}$$

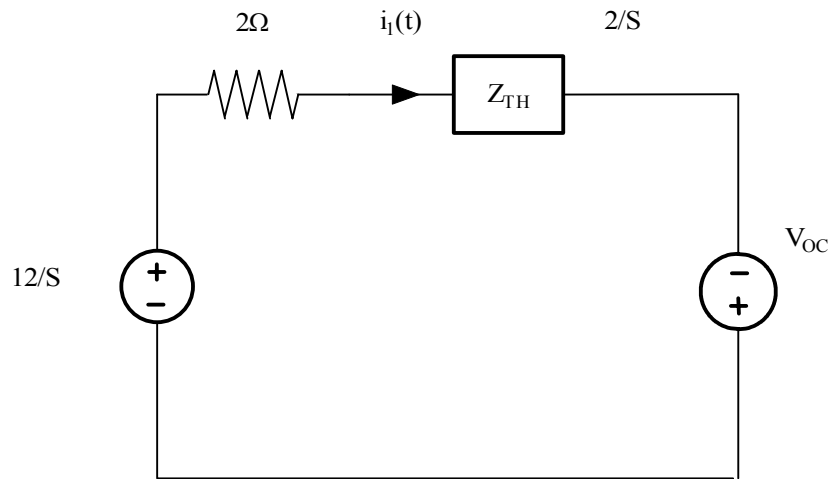
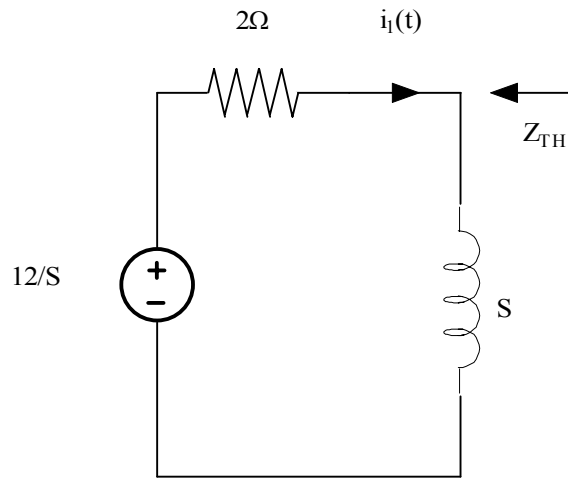

Problem 13.5

For the network shown in fig 13.5 find $i_o(t), t > 0$.

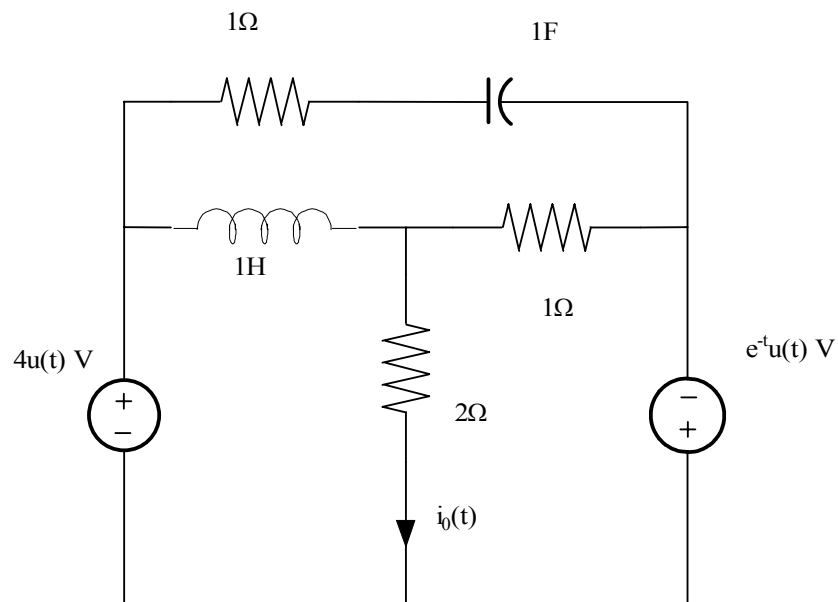

Suggested Solution

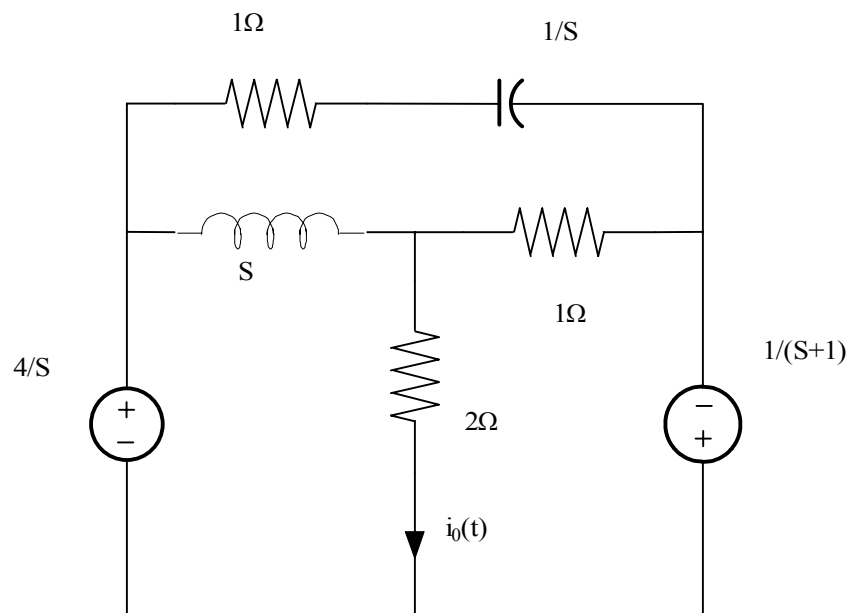

$$V\left(\frac{1}{S} + \frac{1}{2} + 1\right) = \frac{4}{S^2} - \frac{1}{S+1}$$

$$V = \frac{2(-S^2 + 4S + 4)}{S(S+1)(3S+2)}$$

$$I_o = 0.5V = \frac{(-S^2 + 4S + 4)}{S(S+1)(3S+2)}$$

$$i_o(t) = (2 - 16.12e^{-t} - 4/3e^{-2t/3})u(t)V$$

Problem 13.6

For the network shown in fig 13.5 find $V_o(t), t > 0$.

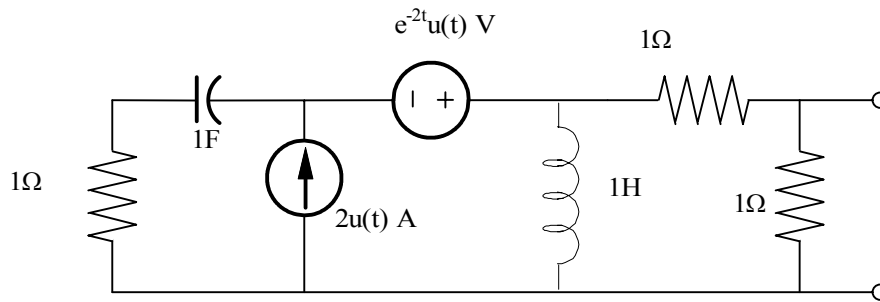

Suggested Solution

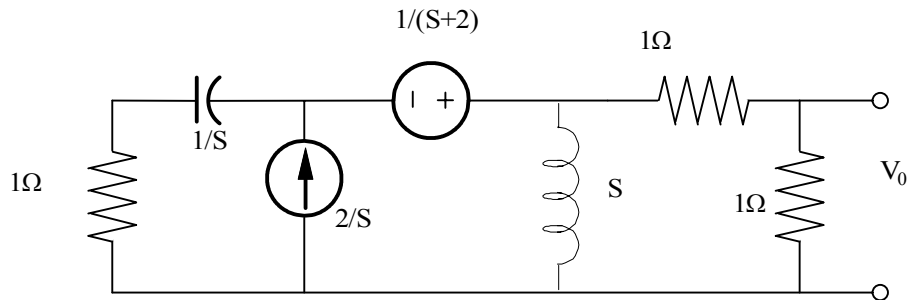

KCL at the Supernode is:

$$\frac{V_1}{1 + 1/S} + \frac{V_2}{S} + \frac{V_2}{2} = \frac{2}{3}$$

$$V_1 + \frac{1}{S+2} = V_2$$

SOLVING FOR V_2 YIELDS:

$$V_2 = \frac{2(3S^2 + 6S + 4)}{(S+2)(3S^2 + 6S + 2)} \Rightarrow V_o = \frac{S^2 + 2S + 4/3}{(S+2)(S+0.5 - j.646)(S+0.5 + j.646)}$$

$$= \frac{K_1}{S+2} + \frac{K_2}{(S+0.5 - j.646)} + \frac{K_2}{(S+0.5 + j.646)}$$

$$K_1 = 0.5, K_2 = 0.316 \angle -37.76^\circ$$

$$\therefore V_o(t) = (0.5e^{-2t} + 0.632e^{-2t} \cos(0.646t - 37.76^\circ))u(t) V$$

Problem 13.7

For the network shown in fig 13.5 find $V_o(t), t > 0$.

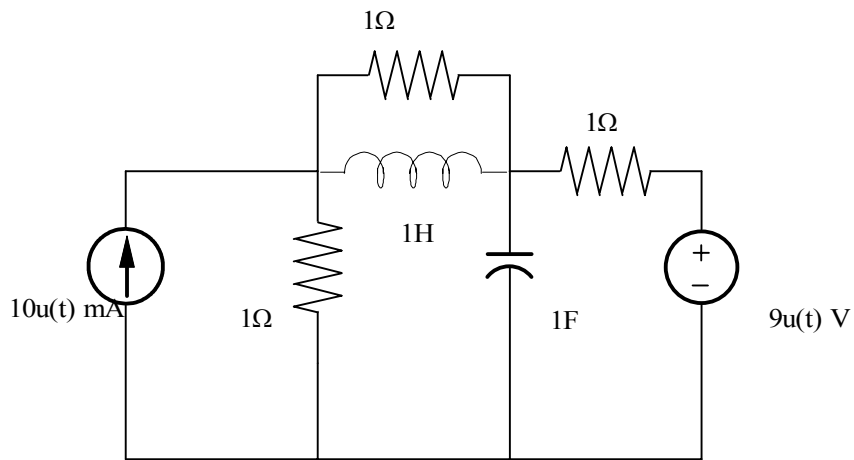

Suggested Solution

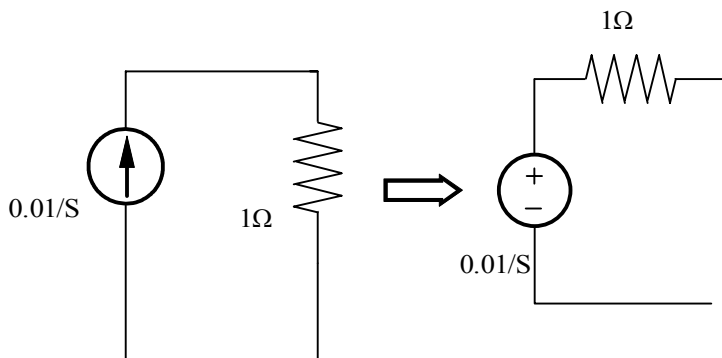
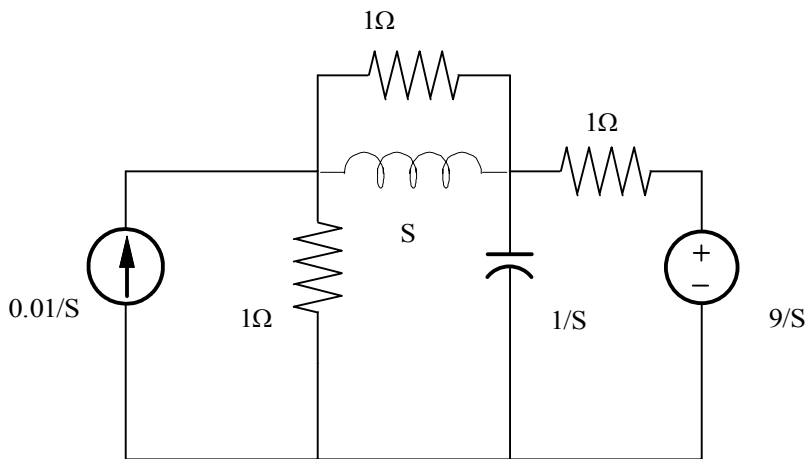

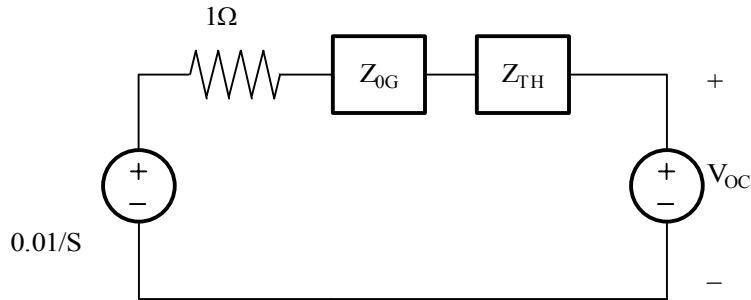
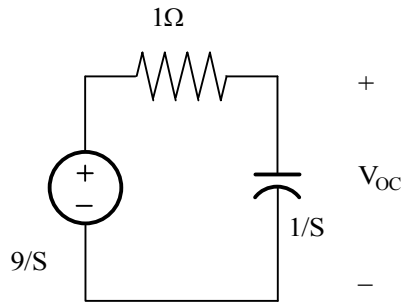

$$V_{OC} = \frac{9}{S} \left(\frac{1/S}{1+1/S} \right) = \frac{9}{S(S+1)}$$

$$Z_{TH} = 1 \parallel 1/S = \frac{1}{S+1}$$

$$V = \left(\frac{10^{-2}}{S} - V_{OC} \right) \left(\frac{Z_{EQ}}{Z_{EQ} + Z_{TH} + 1} \right) = \frac{0.005(S-899)}{(S+1)^2}$$

$$V = \frac{A}{(S+1)^2} + \frac{B}{S+1}$$

$$A = -4.5$$

$$V(899) = 0 = \frac{A}{(900)^2} + \frac{B}{900} \Rightarrow B = 5 \cdot 10^{-3}$$

$$V(t) = (5e^{-t} - 4500te^{-t})u(t) \text{ mV}$$

Problem 13.8

Find $V_o(t), t > 0$ in the network shown in fig using node equations.

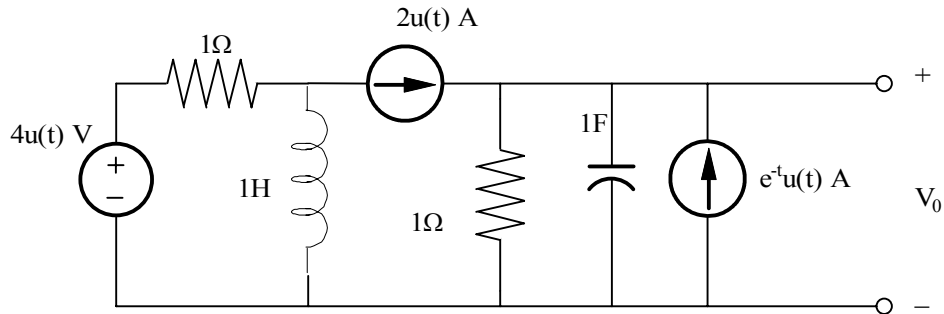

Suggested Solution

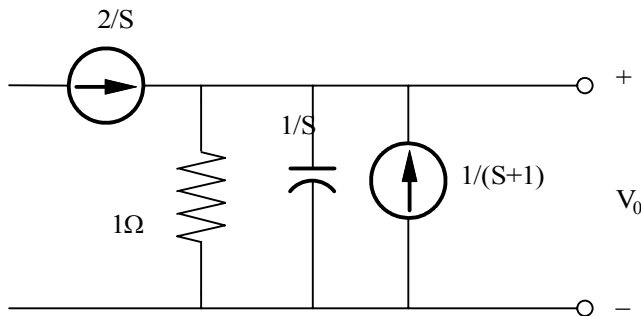

$$\frac{2}{S} + \frac{1}{S+1} = \frac{V_o}{1} + SV_o = V_o(S+1)$$

$$V_o = \frac{2+3S}{S(S+1)^2} = \frac{A}{S} + \frac{B}{(S+1)^2} + \frac{C}{S+1}$$

$$A = 2$$

$$B = 1$$

$$\text{LET } S = -2, V_o(-2) = 2 = -0.5A + B - C \Rightarrow C = -2$$

$$V_o(t) = [2 + 2e^{-t} + te^{-t}]u(t)V$$

Problem 13.9

Find $V_o(t), t > 0$ in the network shown in fig using node equations.

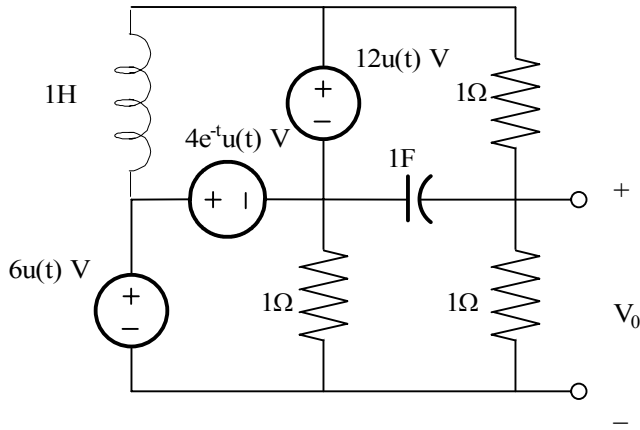

Suggested Solution

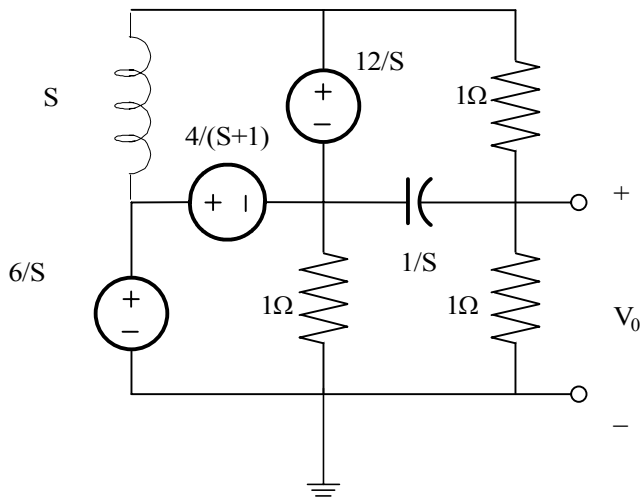

$$KCL: V_3 - V_o + (V_2 - V_o)S = V_o \Rightarrow V_o = \frac{V_3 + SV_2}{S+2}$$

$$V_2 = \frac{6}{S} - \frac{4}{S+1} = \frac{2S+6}{S(S+1)}$$

$$V_3 - V_2 + \frac{12}{S} = \frac{14S+18}{S(S+1)}$$

$$V_o = \frac{2(S+9)}{S(S+2)}$$

$$V_o = \frac{A}{S} + \frac{B}{(S+2)}$$

$$A = 9$$

$$B = -7$$

$$V_o(t) = [9 - 7e^{-2t}]u(t)V$$

Problem 13.10

For the network shown in fig find $V_o(t), t > 0$ using mesh equations.

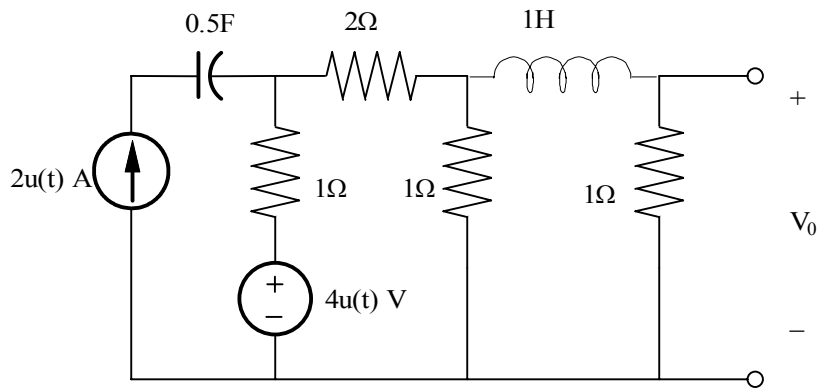

Suggested Solution

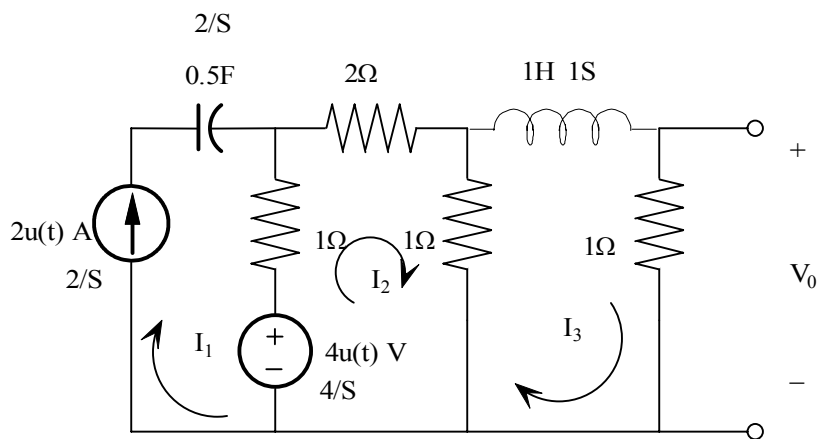

BY MESH ANALYSIS,

$$-I_1 + 4I_2 - I_3 = 4/S$$

$$-I_2 + I_3(S + 2) = 0$$

GIVEN

$$I_1 = 2/S, I_3 \text{ SOLVES TO } \frac{1.5}{S(S+7/4)} = V_o = I_3$$

$$V_o(S) = \frac{1.5}{S(S+7/4)} = \frac{K_1}{S} + \frac{K_2}{(S+7/4)}$$

$$K_1 = 6/7, K_2 = -6/7$$

$$V_o(S) = \frac{6}{7} \left(\frac{1}{S} - \frac{1}{(S+7/4)} \right)$$

$$V_o(t) = \left[\frac{6}{7} (1 - e^{-7/4t}) \right] u(t) V$$

Problem 13.11

For the network shown in fig find $V_o(t), t > 0$ using mesh equations.

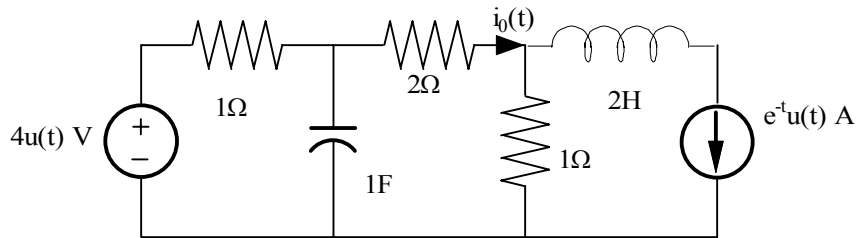

Suggested Solution

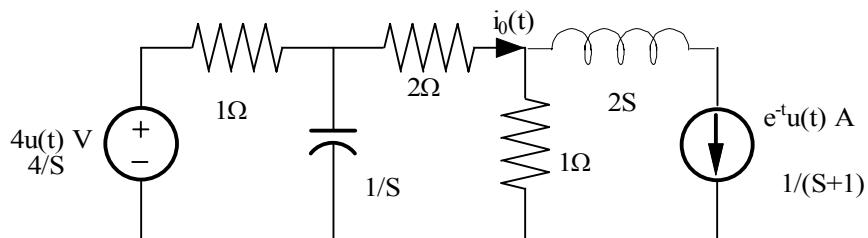

$$\frac{4}{S} - V_1 = V_1 S + I_o$$

$$I_o = V_2 + \frac{1}{(S+1)} = \frac{V_1 - V_2}{2}$$

YIELDS:

$$I_o(S) = \left(\frac{1}{S} - \frac{2}{(3S+4)} \right)$$

$$I_o(t) = \left[\left(1 - \frac{2}{3} e^{-4/3t} \right) \right] u(t) A$$

Problem 13.12

Use loop equations to find $V_o(t), t > 0$ in the network shown in fig.

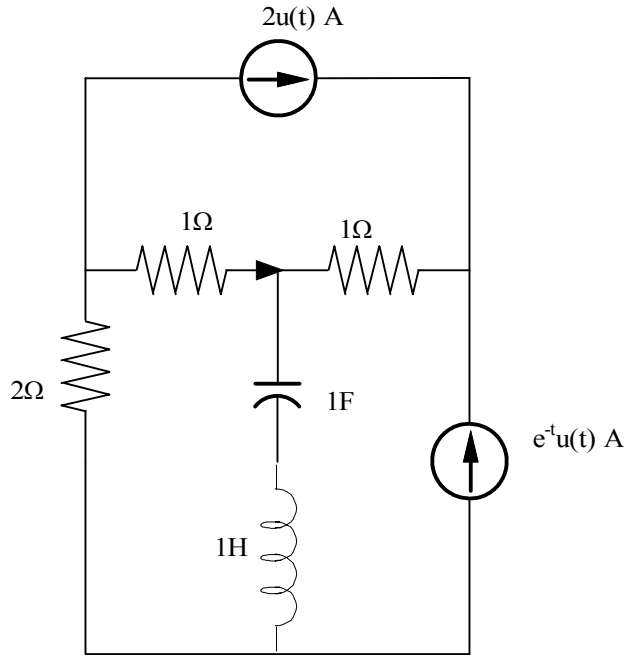

Suggested Solution

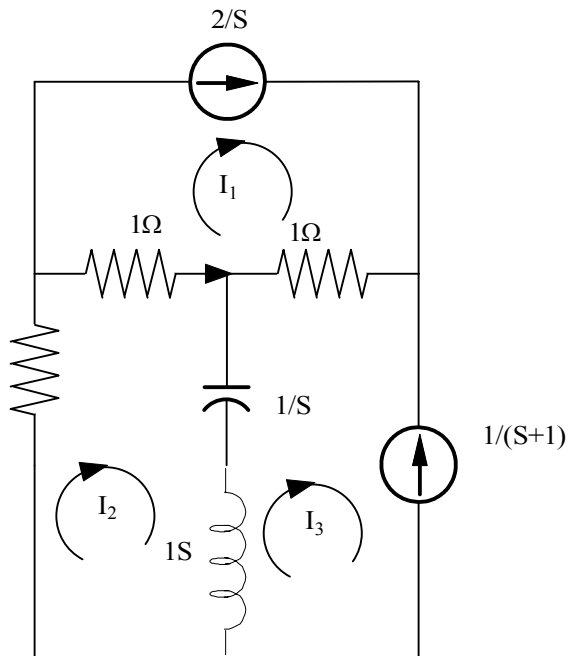

$$I_1 = \frac{2}{S}, I_3 = -\frac{1}{(S+1)}$$

$$2I_2 + (I_2 - I_1) + (S + \frac{1}{S})(I_2 - I_3) = 0$$

$$I_2(2+1+S+\frac{1}{S}) = \frac{2}{S} + \frac{S}{(S+1)} + \frac{1}{S(S+1)}$$

$$I_2(S) = \frac{S^2 + 2S + 3}{(S+1)(S^2 + 3S + 1)}$$

$$I_o = I_2 - I_1 = \frac{-(S^3 + 6S^2 + 8S + 2)}{S(S+1)(S+2.62)(S+0.381)} = -\frac{2}{S} - \frac{2}{(S+1)} + \frac{1.28}{S+2.62} + \frac{1.72}{S+0.38}$$

$$l_o(t) = (-2 - 2e^{-t} + 1.28e^{-2.62t} + 1.72e^{-0.38t})u(t)A$$

Problem 13.13

Use loop equations to find $V_o(t), t > 0$ in the network shown in fig.

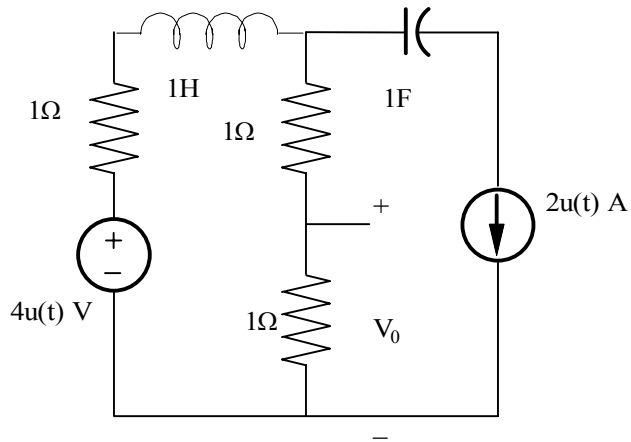

Suggested Solution

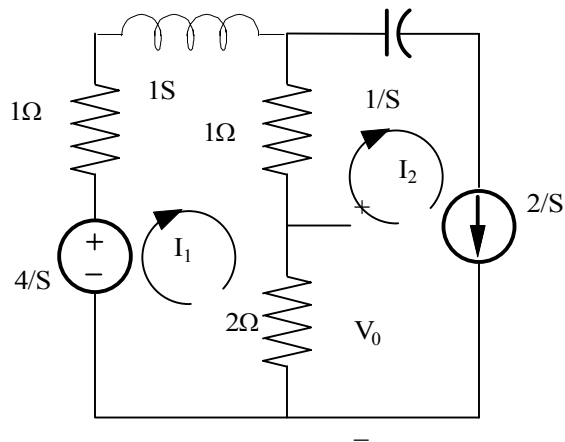

Mesh eq's:

$$\frac{4}{S} = (S + 4)I_1 - 3I_2$$

$$I_2 = \frac{2}{S}$$

$$I_1 = \frac{10}{S(S + 4)}$$

$$V_o = (I_1 - I_2)2$$

$$V_o = \left(\frac{10}{S(S+4)} - \frac{2}{S} \right) 2 = \frac{-2S+2}{S(S+4)} 2 = \frac{-4S+4}{S(S+4)}$$

$$V_o = \left(\frac{B}{(S+4)} + \frac{A}{S} \right)$$

$$A = 1$$

$$B = -5$$

$$V_o(t) = (1 + 5e^{-4t})u(t)V$$

Problem 13.14

Use mesh equations to find $i_o(t), t > 0$ in the network shown in fig.

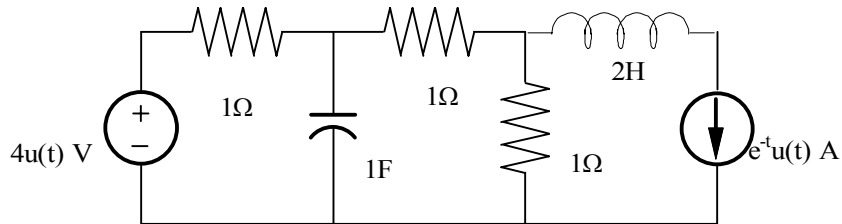

Suggested Solution

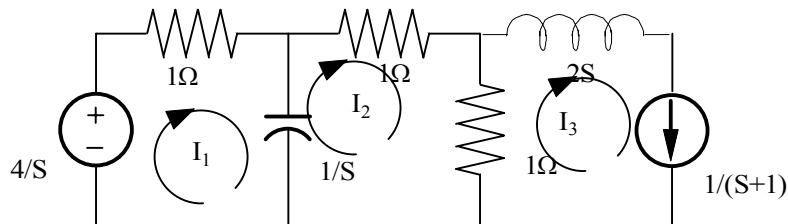

$$I_o = I_2$$

$$I_3 = \frac{1}{S+1}$$

$$\frac{4}{S} = (1/S + 1)I_1 - I_2/S$$

$$0 = -(1/S)I_1 + I_2(3 + 1/S) - I_3$$

SOLVING 1 FOR I_1 & PUT INTO 2.

$$I_1 = \frac{I_2 + 4}{(S+1)} \Rightarrow I_2 \left[3S + 1 - \frac{1}{S+1} \right] = \frac{S}{(S+1)} + \frac{4}{S+1} = \frac{S+4}{S+1}$$

SO

$$I_o = \frac{\frac{S+4}{S+1}}{\frac{3S^2 + 4S}{S+1}} = \frac{(4+S)/3}{S(S+4/3)} = \frac{B}{(S+4/3)} + \frac{A}{S}$$

$$A = 1$$

$$B = -\frac{2}{3}$$

$$i_o(t) = \left(1 - \frac{2}{3}e^{-4t/3}\right)u(t)V$$

Problem 13.15

Use loop equations to find $V_o(t), t > 0$ in the network shown in fig.

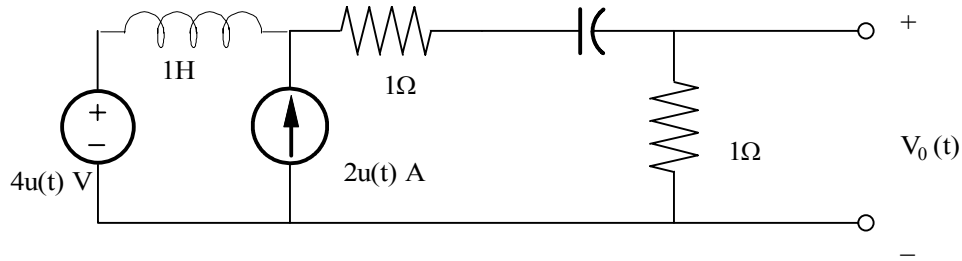

Suggested Solution

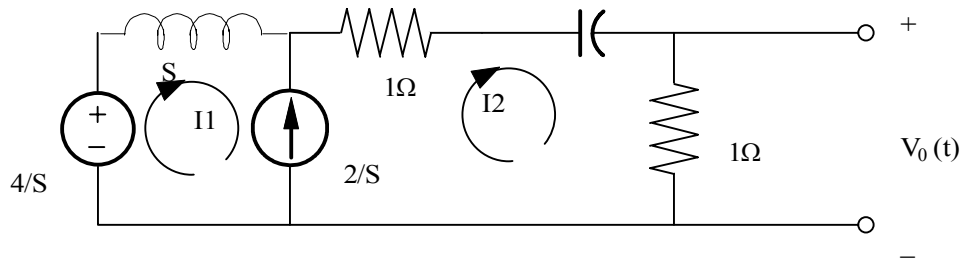

MESH EQUATIONS:

$$V_o = I_2$$

$$\frac{4}{S} = SI_1 + I_2\left(2 + \frac{2}{S}\right) \quad \& \quad I_2 - I_1 = \frac{2}{S}$$

SO

$$I_1 = I_2 - \frac{2}{S}$$

AND

$$\frac{4}{S} = -2 + I_2\left(2 + \frac{2}{S} + S\right) \Rightarrow I_2 = \frac{2S + 4}{S^2 + 2S + 2} = \frac{K|\underline{\theta}}{S + 1 - j1} + \frac{K|-\underline{\theta}}{S + 1 + j1}$$

$$K|\underline{\theta} = \frac{2(-1 + j1)}{j2} = \sqrt{2} \underline{-45^\circ}$$

$$V_o(t) = 2\sqrt{2}e^{-t} \text{COS}(t - 45^\circ)u(t) \text{ V}$$

Problem 13.16

Use loop analysis to find $V_o(t), t > 0$ in the network shown in fig.

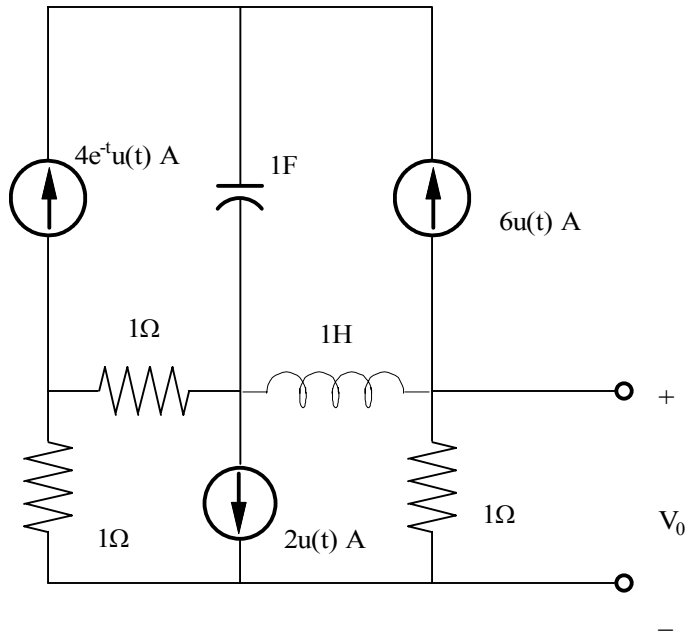

Suggested Solution

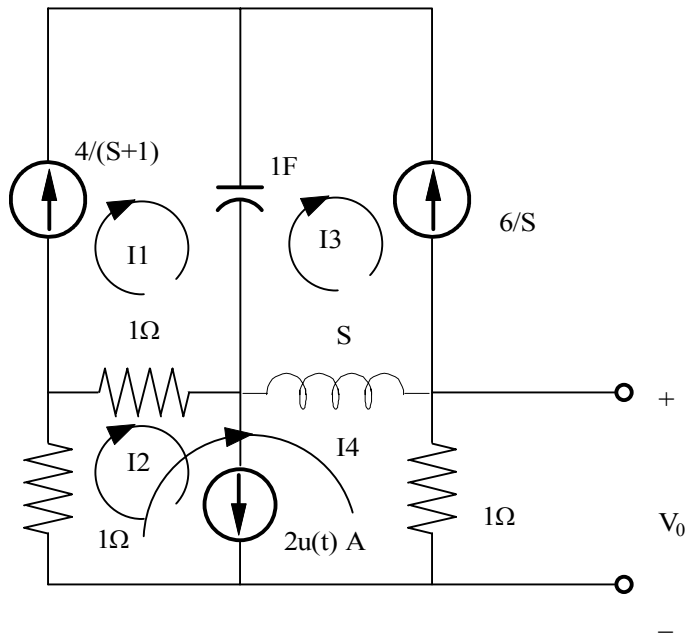

$$I_1 = \frac{4}{S+1}$$

$$I_2 = \frac{2}{S}$$

$$I_3 = \frac{-6}{S}$$

KVL FOR LOOP 4 IS

$$1(I_2 - I_1) + 1(I_2 - I_1 + I_4) + S(-I_3 + I_4) + I_4 = 0$$

$$I_4 = \frac{-(6S^2 + 6S + 4)}{S(S+1)(S+3)}$$

$$1(I_2 - I_1) + 1(I_2 - I_1 + I_4) + S(-I_3 + I_4) + I_4 = 0$$

$$I_4 = \frac{-(6S^2 + 6S + 4)}{S(S+1)(S+3)} = \frac{-4/3}{S} + \frac{2}{S+1} - \frac{20/3}{S+3}$$

SINCE

$$V_o(t) = (1)I_4$$

$$V_o(t) = \left(-\frac{4}{3} + 2e^{-t} - \frac{20}{3}e^{-3t}\right)u(t)V$$

Problem 13.17

Use mesh analysis to find $V_o(t), t > 0$ in the network shown in fig.

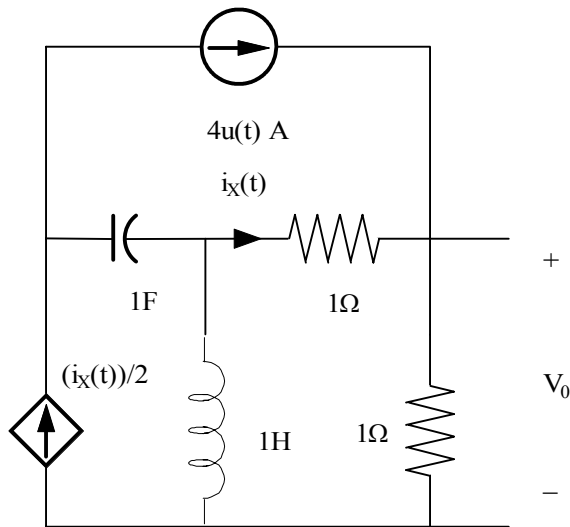

Suggested Solution

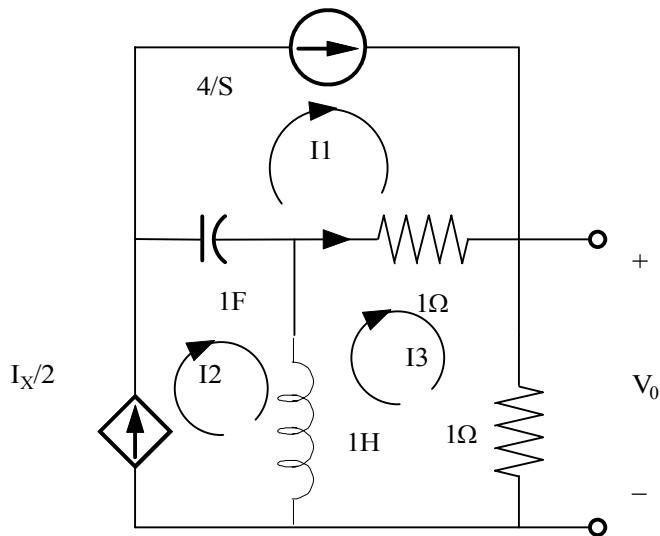

$$I_1 = \frac{4}{S}$$

$$I_2 = \frac{I_X}{2}$$

$$I_X = I_3 - \frac{4}{S}$$

THEN KVL FOR THE MESH - 3:

$$S[I_3 - 0.5(I_3 - 4/S)] + 1[I_3 - 4/S] + I_3 = 0$$

$$\therefore I_3 = \frac{-4(S-2)}{S(S+4)} \text{ \& } V_o = I_3(1) = \frac{2}{3} + \frac{-6}{S+4}$$

$$V_o(t) = (2 - 6e^{-4t} - \frac{20}{3}e^{-3t})u(t)V$$

Problem 13.18

Use loop equations to find $V_o(t), t > 0$ in the network shown in fig.

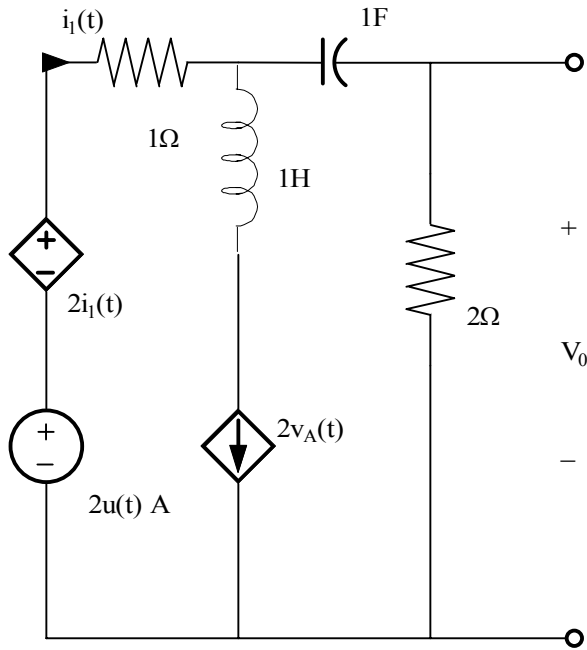

Suggested Solution

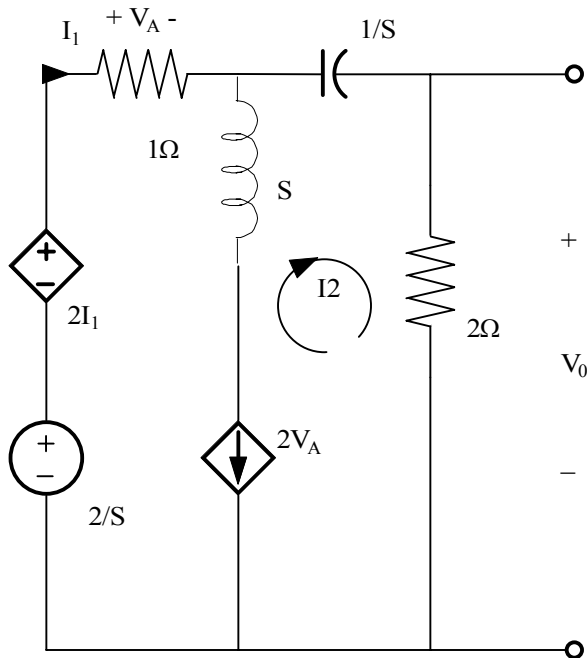

$$\frac{2}{S} + 2I_1 = I_1(1) + I_2\left(2 + \frac{1}{S}\right)$$

OR

$$2 = -SI_1 + I_2(2S + 1)$$

ALSO

$$I_1 - I_2 = 2VA = 2I_1(1) \Rightarrow I_1 = -I_2$$

NOW,

$$2 = I_2[S + 2S + 1] \Rightarrow I_2 = \frac{2}{3S + 1} = \frac{2/3}{S + 1/3}$$

$$V_o = 2I_1 = \frac{2/3}{S + 1/3}$$

$$V_o(t) = \frac{4}{3} e^{-t/3} u(t) V$$

Problem 13.19

Use superposition to find $V_o(t), t > 0$ in the network shown in fig.

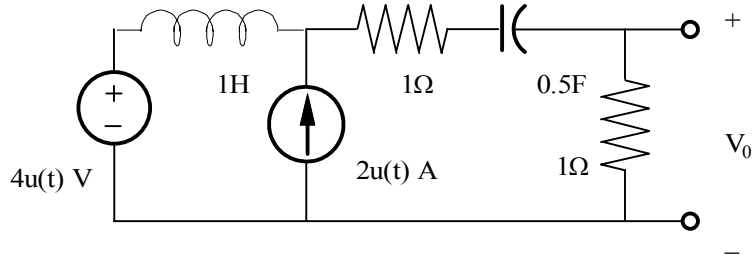

Suggested Solution

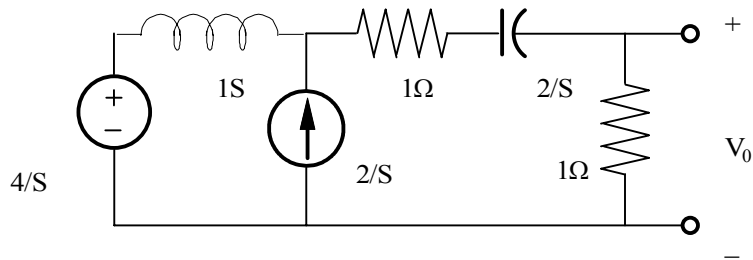

FOR THE 4V SOURCE,

$$V_o(S) = \frac{4}{S} \frac{1}{S+2+2/S} = \frac{4}{S^2+2S+2}$$

FOR THE 2A SOURCE:

$$V_o(S) = \frac{2}{S} \cdot S \parallel (2+2/S) = \frac{2S}{S^2+2S+2}$$

$$\text{FINALLY, } V_o(S) = \frac{4}{S^2+2S+2} + \frac{2S}{S^2+2S+2} = \frac{2S+4}{S^2+2S+2}$$

AS IN P 16.5,

$$V_o(S) = \frac{2S+4}{S^2+2S+2}$$

YIELDS

$$V_o(t) = 2\sqrt{2}e^{-t}\text{COS}(+45^\circ)u(t)V$$

Problem 13.20

Use source transformation to solve problem 13.19.

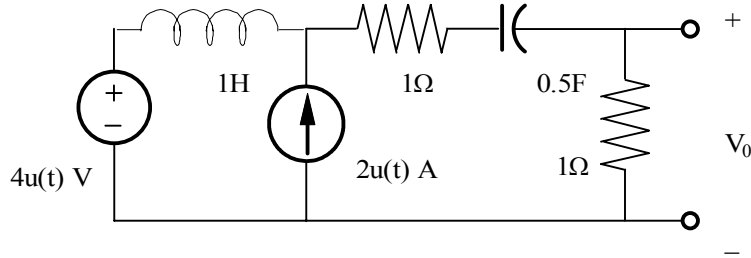

Suggested Solution

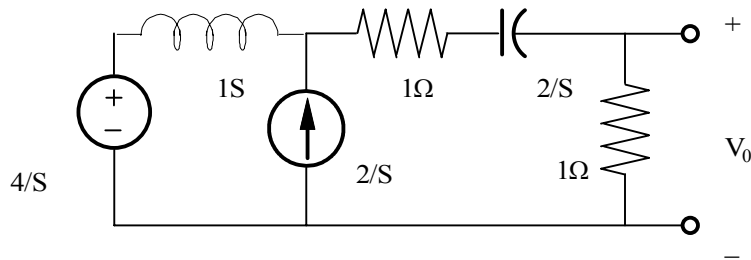

$$V_I(S) \left[\frac{1}{S} + \frac{1}{2 + 2/S} \right] = \frac{4}{S^2} + \frac{2}{S}$$

$$V_I(S) = \frac{S(2S+2)(2S+4)}{S^2(S^2+2S+2)}$$

$$V_O(S) = V_I(S) \left[\frac{1}{2 + 2/S} \right]$$

$$V_O(S) = \frac{(2S+4)}{(S^2+2S+2)} = \frac{K_1}{S+1-r} + \frac{K_1}{S+1+r}$$

$$K_1 = \left. \frac{(2S+4)}{(S+1-r)} \right|_{S=-1+r} = \sqrt{2} \angle -45^\circ$$

$$K_1 = \left. \frac{(2S+4)}{(S+1-r)} \right|_{S=-1+r} = \sqrt{2} \angle -45^\circ$$

$$V_O(S) = \frac{\sqrt{2} \angle -45^\circ}{(S+1-r)} + \frac{\sqrt{2} \angle -45^\circ}{(S+1+r)}$$

$$V_O(t) = 2\sqrt{2}e^{-t} \text{COS}(t - 45^\circ) u(t) V$$

Problem 13.21

Use Thevenin's theorem to solve problem 13.19.

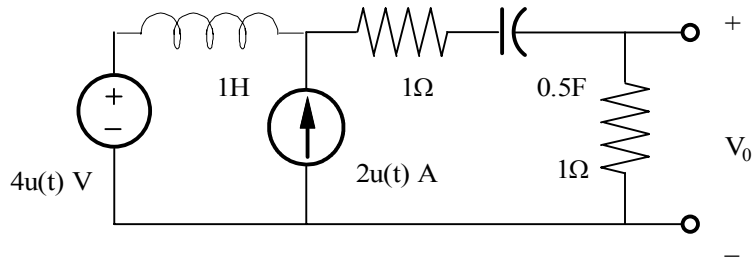

Suggested Solution

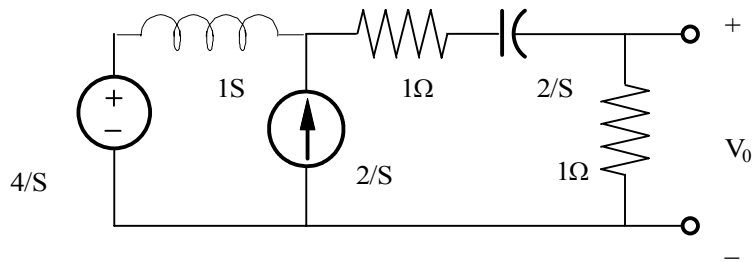

WITH THE OUTPUT RESISTOR AS A LOAD,

$$V_{oc} = \frac{4}{S} + \frac{2}{S} S = \frac{2S+4}{S}$$

$$Z_{TH} = \frac{2}{S} + 1 + S = \frac{S^2 + S + 2}{S}$$

BY VOLTAGE DIVISION,

$$V_o(S) = \frac{\frac{2S+4}{S} \cdot 1}{\frac{S^2+S+2}{S} + 1} = \frac{2S+4}{S^2+S+2}$$

$$|FV_o(S)| = \frac{2S+4}{S^2+S+2}$$

$$V_o(t) = 2\sqrt{2}e^{-t} \text{COS}(t - 45^\circ)u(t)$$

Problem 13.22

Use Thevenin's theorem to solve problem 13.11.

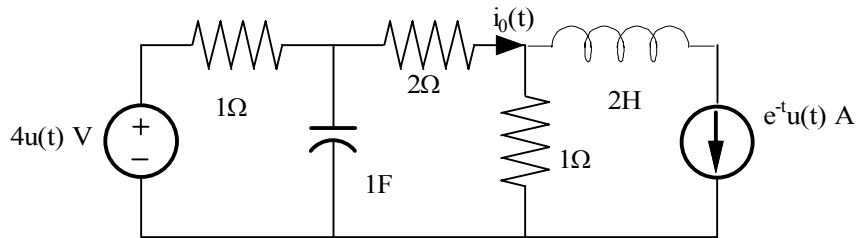

Suggested Solution

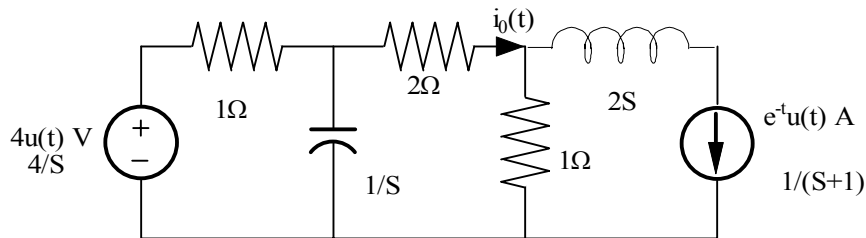

$$V_{oc} = \frac{4}{S} \cdot \frac{1/S}{1+1/S} + \frac{1}{S+1} = \frac{S+4}{S(S+1)}$$

$$Z_{TH} = 1+1 \parallel 1/S = \frac{1/S}{1+1/S} + 1 = \frac{S+2}{S+1}$$

$$I_o(S) = \frac{V_{oc}}{Z_{TH} + 2} = \frac{S+4}{S(S+1)} \frac{S+1}{3S+4} = \frac{S+4}{S(3S+4)}$$

$$i_o(t) = \left[1 - \frac{2}{3} e^{-4/3t} \right] u(t)$$

Problem 13.23

Use Thevenin's theorem to find $V_o(t), t > 0$ in the network.

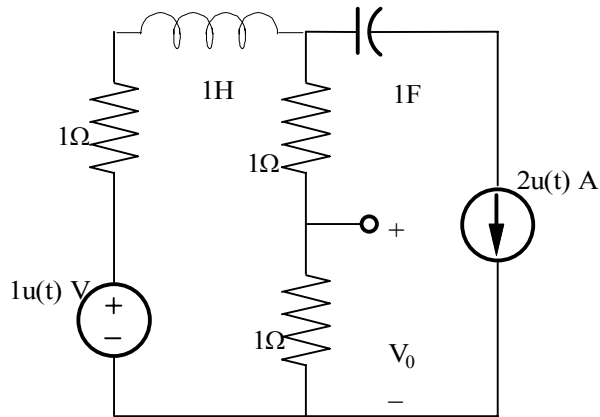

Suggested Solution

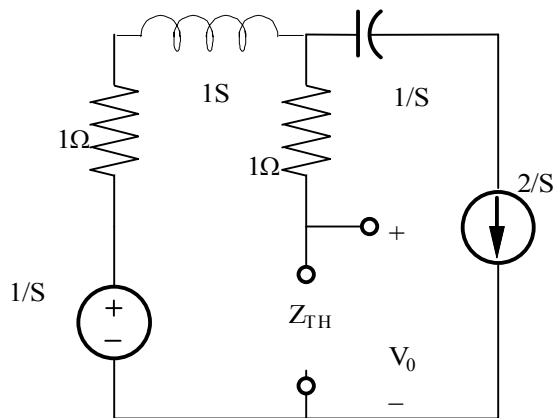

Using superposition

$$V_{oc} = \frac{1}{S} - \frac{2}{S}(2s+1) = -\frac{(4s+1)}{s}$$

$$Z_{TH} = 2s+2$$

$$V_o = V_{oc} \left(\frac{1}{Z_{TH} + 1} \right) = \frac{-(4S+1)}{(2S+3)S} = -\frac{(2S+1/2)}{S(S+3/2)}$$

$$V_o = \frac{A}{S} + \frac{B}{S+3/2}$$

$$A = -1/3$$

$$B = -5/3$$

$$V_o(t) = \left[-\frac{1}{3} - \frac{S}{3} e^{-3/2t} \right] \mu(t) V$$

Problem 13.24

Use Thevenin's theorem to find $i_0(t), t > 0$ in the circuit shown.

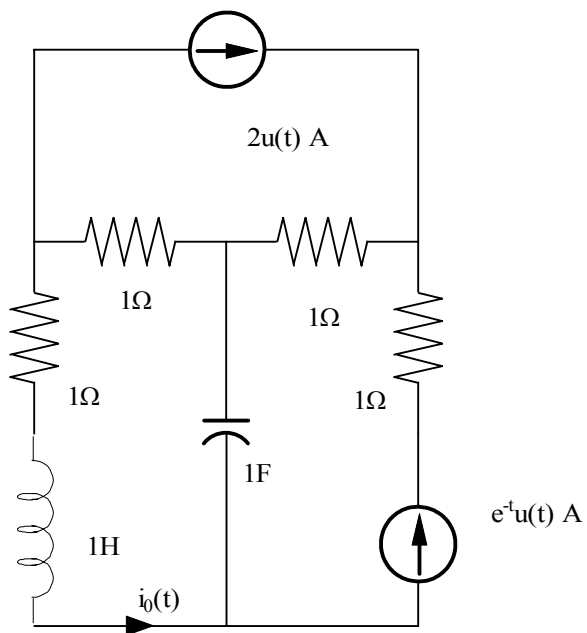

Suggested Solution

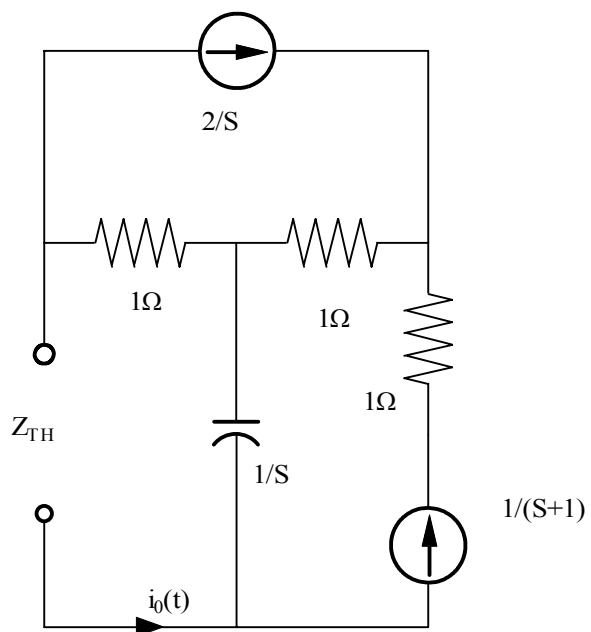

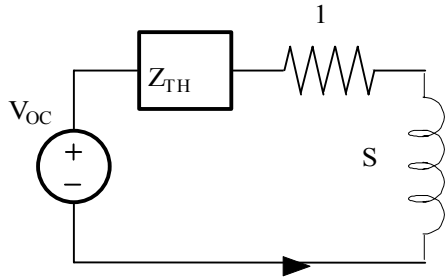

$$V_{OC} = \left(\frac{1}{S+1}\right)\left(\frac{1}{S}\right) - \left(\frac{2}{S}\right)(1) = \frac{-(2S+1)}{S(S+1)}$$

$$Z_{TH} = 1 + \frac{1}{S} = \frac{S+1}{S}$$

$$I_o = \frac{-V_{OC}}{1+S+Z_{TH}} = \frac{\frac{(2S+1)}{S(S+1)}}{1+S+\frac{S+1}{S}} = \frac{(2S+1)}{(S+1)(S+1+S(S+1))}$$

$$I_o = \frac{(2S+1)}{(S+1)^3} = \frac{A}{(S+1)^3} + \frac{B}{(S+1)^2} + \frac{C}{(S+1)}$$

$$A = -1$$

$$\text{LET, } S = 0, I_o(0) = 1 = A + B + C \Rightarrow B + C = 2$$

$$\text{LET, } S = -0.5, I_o(-0.5) = 0 = 8A + 4B + 2C \Rightarrow 4B + 2C = 8$$

$$\text{SOLUTIONS ARE } B=Z \text{ AND } C=0 \text{ SO, } I_o = -\frac{1}{(S+1)^3} + \frac{2}{(S+1)^2}$$

$$i_o(t) = \left(2te^{-t} - \frac{t^2}{2}e^{-t}\right)u(t)A$$

Problem 13.25

Use Thevenin's theorem to find $V_o(t), t > 0$ in the network.

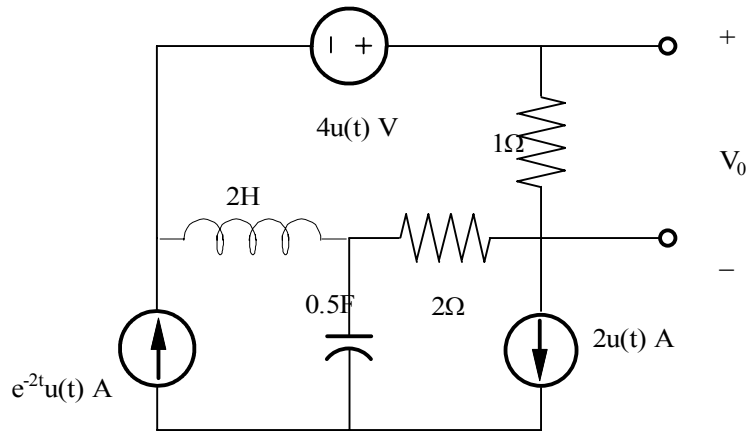

Suggested Solution

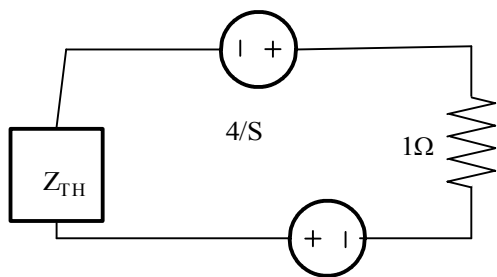
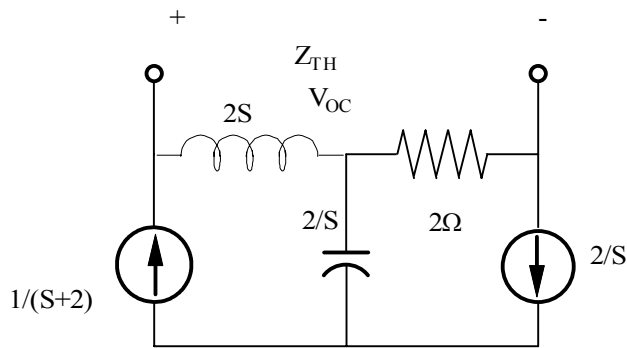

USING SUPERPOSITION,

$$V_{oc} = \left(\frac{1}{S+2}\right)2S + \left(\frac{2}{S}\right)^2 = \left(\frac{2S}{S+2}\right) + \frac{4}{S} = \frac{2S^2 + 4S + 8}{S(S+2)}$$

$$Z_{TH} = 2S + 2$$

$$V_o = \frac{V_{oc} + 4/S}{1 + Z_{TH}} = \frac{2S^2 + 8S + 16}{S(S+2)(2S+3)}$$

$$V_o = \frac{2S^2 + 8S + 16}{S(S+2)(2S+3)} = \frac{A}{S} + \frac{B}{S+2} + \frac{C}{C+1.5}$$

$$A = 8/3$$

$$B = 4$$

$$C = -17/3$$

$$V_o(t) = \left(\frac{8}{3} + 4e^{-2t} - \frac{17}{3}e^{-3t/2}\right)u(t)V$$

Problem 13.26

Use Thevenin's theorem to find $V_o(t), t > 0$ in the network.

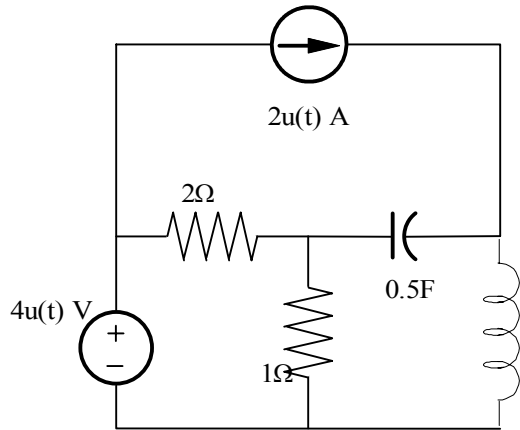

Suggested Solution

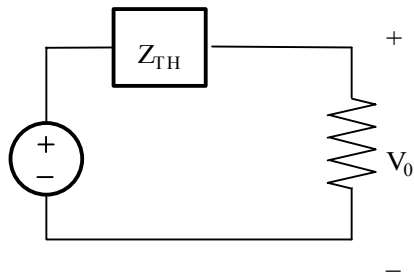
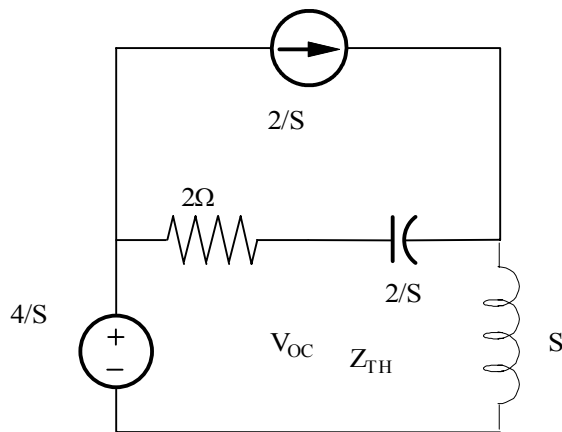

USING SUPERPOSITION,

$$V_{oc} = \frac{4}{S} \left[\frac{S + 2/S}{S + 2 + 2/S} \right] + \frac{2}{S} \left[\frac{S}{S + 2 + 2/S} \right] 2$$

$$V_{oc} = \frac{8S^2 + 8}{S(S + 1 - j1)(S + 1 + j1)}$$

$$V_o = \frac{V_{oc}(1)}{1+Z_{TH}} = \frac{8S+8/S}{S^2 + 2S + 2 + 2S^2 + 4}$$

$$V_o = \frac{(8/3)(S^2 + 1)}{S(S^2 + (2/3)S + 2)}$$

$$A = 4/3$$

$$K|\theta = 1.273|10.05^\circ$$

$$V_o(t) = \left(\frac{4}{3} + 2.546e^{-t/3} \cos(\sqrt{17}t + 10.05^\circ)\right)V$$

Problem 13.27

Use Thevenin's theorem to find $V_o(t), t > 0$ in the network.

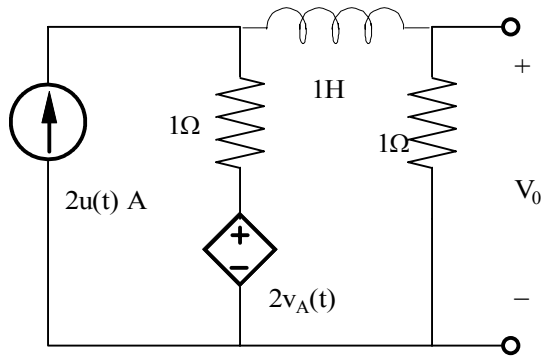

Suggested Solution

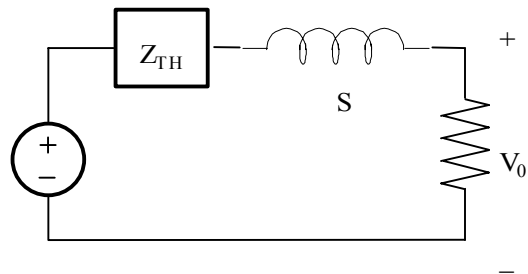
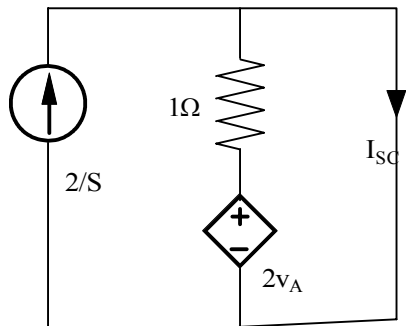
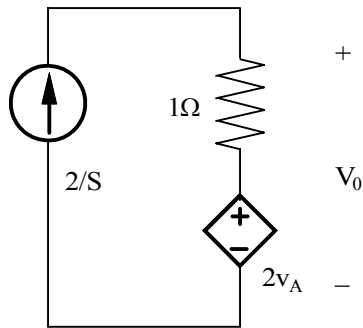

$$V_{OC} = 3V_A$$

$$2/S = V_A$$

SO,

$$V_{OC} = 6/S$$

$$I_{SC} = 2/S$$

$$Z_{TH} = V_{OC} / I_{SC} = 3\Omega$$

$$V_O = \frac{V_{OC}}{S+1+Z_{TH}} = \frac{6/S}{S+4} = \frac{A}{S} + \frac{B}{S+4}$$

$$A = 1.5$$

$$B = -1.5$$

$$V_O(t) = 1.5(1 - e^{-4t})u(t)V$$

Problem 13.28

Use laplace transform to find $V_o(t), t > 0$ in the network. assume that the circuit has reached steady state at $t = 0^-$.

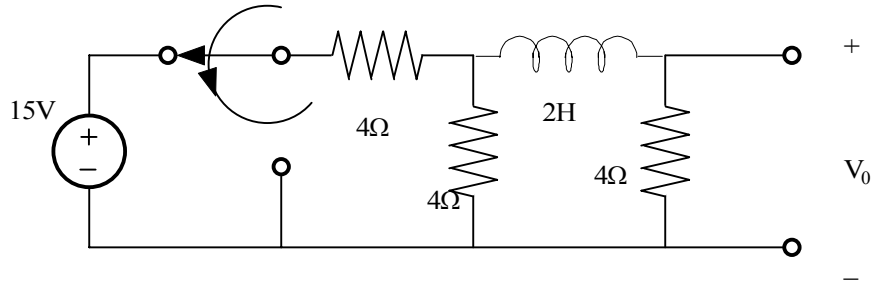

Suggested Solution

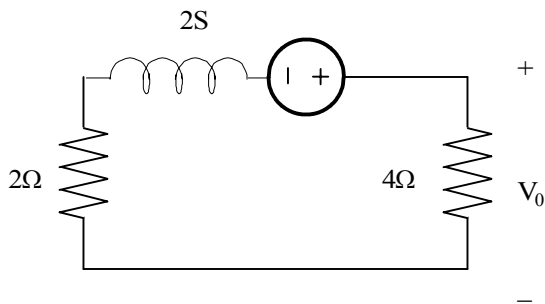
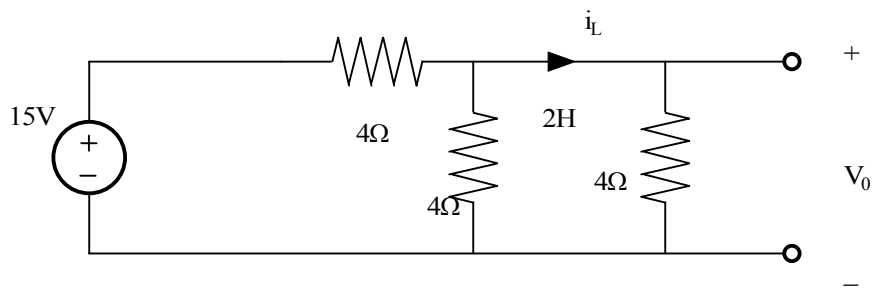

$$V_o = 2.5 \left(\frac{4}{2s+6} \right)$$

$$V_o = \left(\frac{5}{s+3} \right)$$

$$V_o(t) = 5(e^{-3t})u(t)V$$

Problem 13.29

Find $I_o(t), t > 0$ in the network.

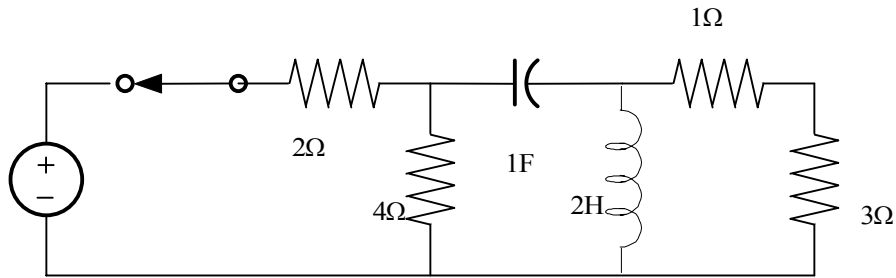

Suggested Solution

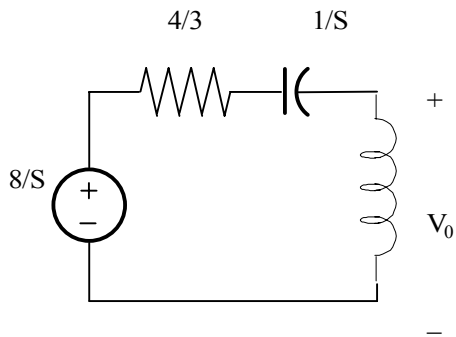
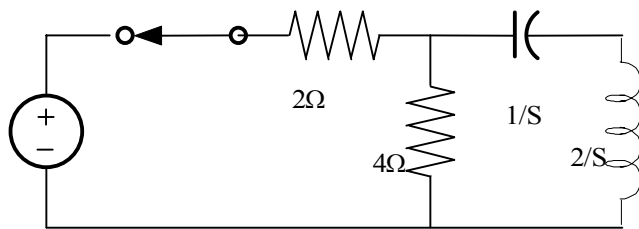

SOURCE TRANSFORMATIONS:

$$i_2(0^-) = 0$$

$$V_c(0^-) = 0$$

$$V_{oc} = \frac{8}{S} \left[\frac{2S}{2S + 4/3 + 1/S} \right] = \frac{16S}{2S^2 + 4S/3 + 1} = \frac{8S}{S^2 + 2S/3 + 1/2}$$

$$Z_{TH} = 2S \parallel (4/3 + 1/S) = \frac{(8)S^2}{6S^2 + 4S + 3} \Omega$$

$$I_{oc} = \frac{V_{oc}}{Z_{TH} + \frac{(48)S^2}{6S^2 + 4S + 3} + 4} = \frac{48S^2}{8S^2 + 6S + 24S^2 + 16S + 12}$$

$$I_o = \frac{(48)S}{52S^2 + 22S + 12} = \frac{1.5S}{S^2 + \frac{11}{16}S + \frac{6}{16}}$$

$$I_o = \frac{K|\theta}{S + \frac{11}{32} - j\frac{\sqrt{263}}{32}} + \frac{K - |\theta|}{S + \frac{11}{32} + j\frac{\sqrt{263}}{32}}$$

$$K|\theta = 0.906|34.15^\circ$$

$$i_o(t) = 1.812e^{-0.34t} \text{COS}(0.51t + 34.15^\circ)u(t)A$$

Problem 13.30

find $I_o(t), t > 0$ in the network.

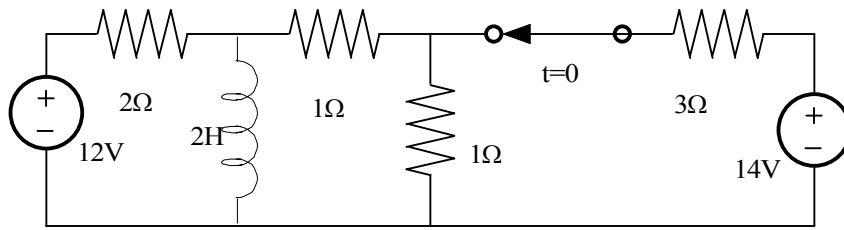

Suggested Solution

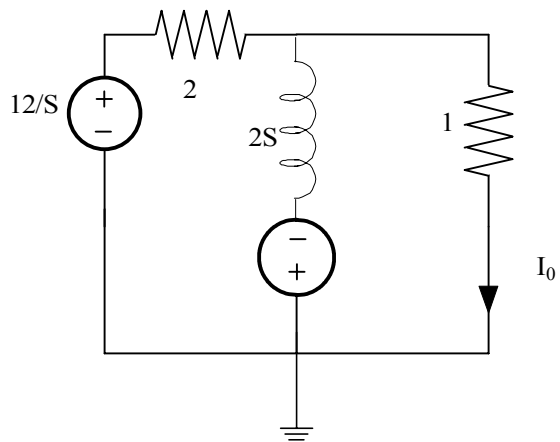
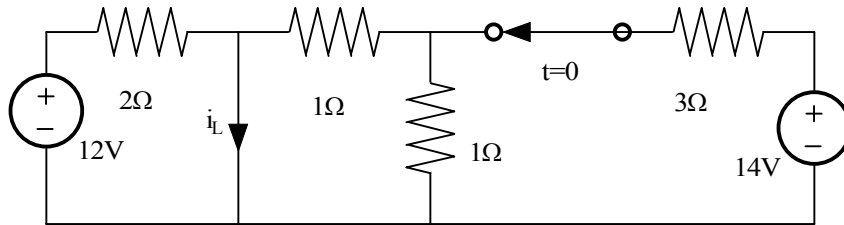

FOR $t=0^-$

$$i_L = \frac{12}{Z} + \frac{14}{3.5} \left(\frac{1}{1+1} \right) = 8A$$

$$\frac{\frac{12}{S} - V}{Z} = \frac{V+16}{2S} + \frac{V}{2} \Rightarrow 12 - SV = V + 16 + S$$

SO,

$$V = \frac{-4}{2S+1}$$

$$I_o = \frac{V}{2} = \frac{-1}{S+0.5}$$

$$i_o(t) = -e^{-0.5t} u(t)A$$

Problem 13.31

Use Thevenin's theorem to find $V_o(t), t > 0$ in the network.

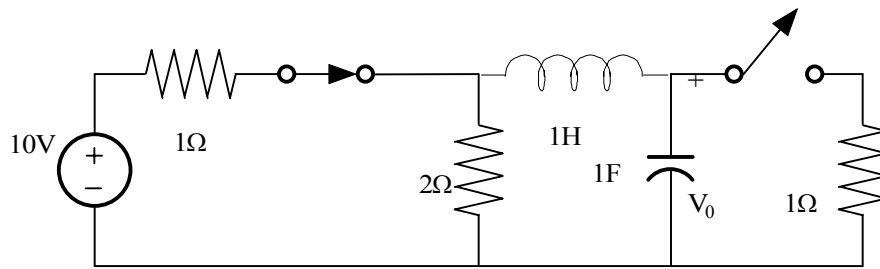

Suggested Solution

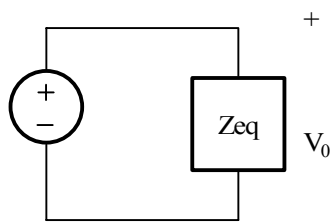
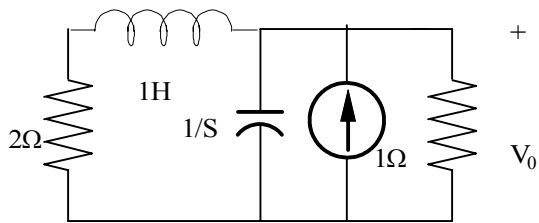
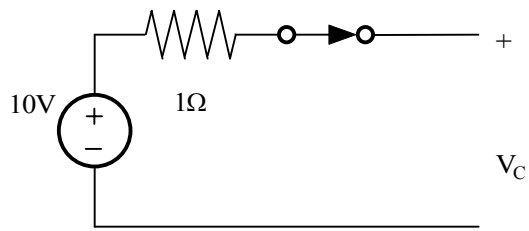

for $t=0^-$

$$i_L = 0$$

$$V_C = \frac{20}{3}V$$

$$Z_{eq} = 1 \parallel \frac{1}{S} \parallel (S+2) = \frac{1}{S+1} \parallel S+2 = \frac{(S+2)/(S+1)}{S+2 + \frac{1}{S+1}}$$

$$Z_{eq} = \frac{(S+2)}{S^2 + 3S + 3}$$

$$V_o = \frac{20}{3} \frac{(S+2)}{\left(S + \frac{3}{2}S - j\frac{\sqrt{3}}{2}\right)\left(S + \frac{3}{2}S + j\frac{\sqrt{3}}{2}\right)}$$

$$V_o = \frac{k|\underline{\theta}}{s+1.5-j\frac{\sqrt{3}}{2}} + \frac{k|-\underline{\theta}}{s+1.5+j\frac{\sqrt{3}}{2}}$$

$$k|\underline{\theta} = \frac{20}{3} \frac{-1.5+j\frac{\sqrt{3}}{2}+2}{j\sqrt{3}} = 3.85 \angle -30^\circ$$

$$V_o(t) = 7.7e^{-3t/2} \cos\left(\frac{\sqrt{3}t}{2} - 30^\circ\right)V$$

Problem 13.32

find $i_o(t), t > 0$ in the network.

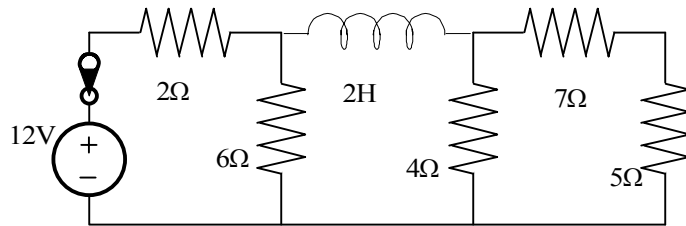

Suggested Solution

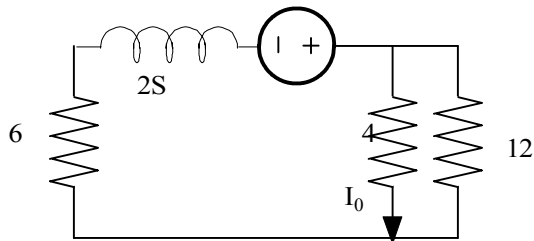
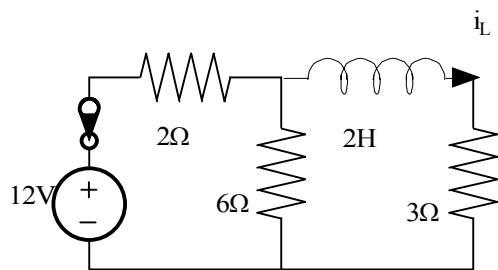

$$i_L(0^-) = 2A$$

THE TRANSFORMED NETWORK FOR $t > 0$ IS

$$I_o = \frac{4}{2S+9} \left(\frac{12}{4+12} \right) = \frac{1.5}{S+9/2}$$

$$i_o(t) = 1.5e^{-9t/2}u(t)A$$

Problem 13.33

find $V_o(t), t > 0$ in the network.

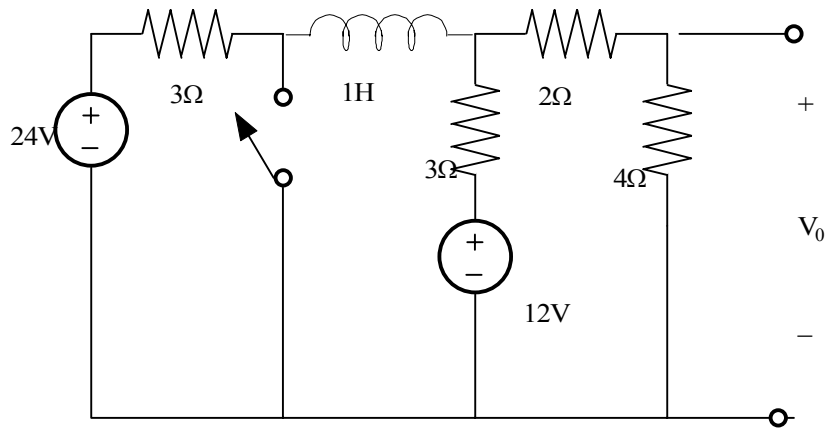

Suggested Solution

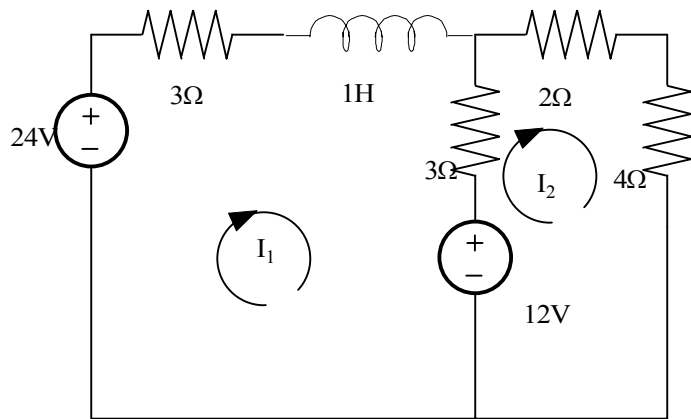

$$6I_1 - 3I_2 = 12$$

$$-3I_1 + 9I_2 = 12$$

$$I_1 = \frac{\begin{vmatrix} 12 & -3 \\ 12 & 9 \end{vmatrix}}{\begin{vmatrix} 6 & -3 \\ -3 & 9 \end{vmatrix}} = \frac{12(9+3)}{54-9} = 144/45$$

$$i_L(O^-) = 3.2A$$

$$\frac{V_1 - 6.4}{2S} + \frac{V_1 + 12/S}{3} + \frac{V_1}{6} = 0$$

SOLVING FOR V_1 YIELDS:

$$V_1 = \frac{14.4}{S+1}$$

$$V_0 = \frac{9.6}{S+1}$$

$$V_o(t) = 9.6e^{-t}u(t)V$$

Problem 13.34

find $V_o(t), t > 0$ in the network.

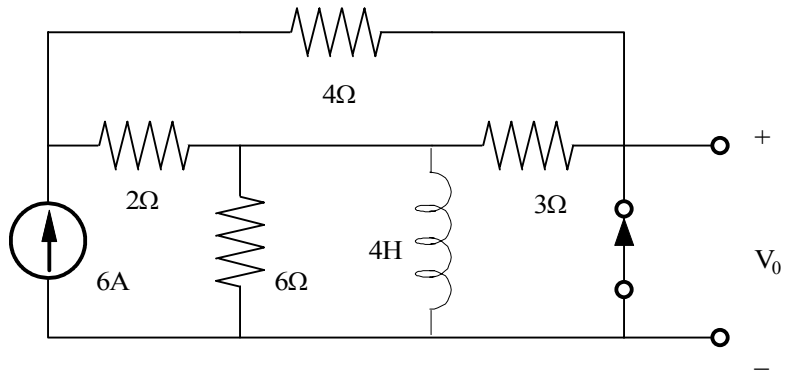

Suggested Solution

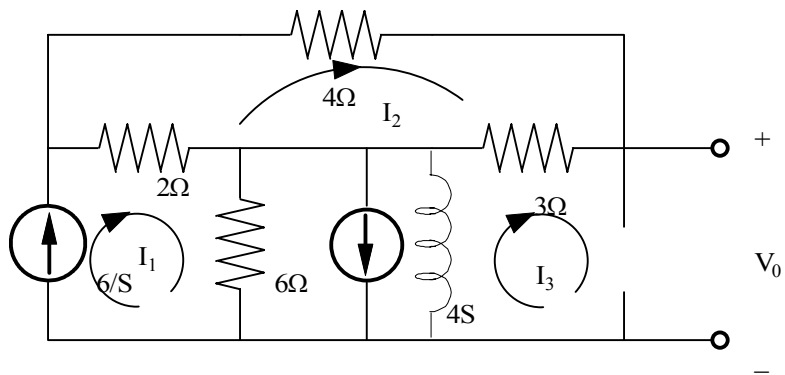
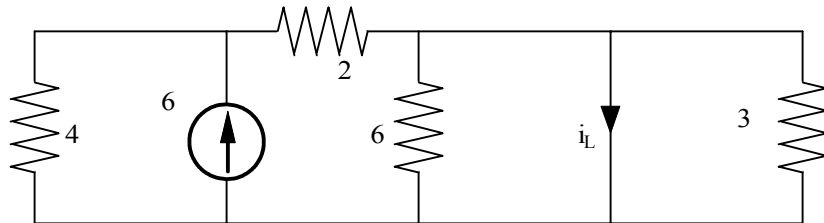

$$\frac{24s}{4s+6} = \frac{12s}{2s+3}$$

$$\text{loop analysis: } I_1 = 6/S, I_3 = 4/S, 9I_2 - 2I_1 = 0 \Rightarrow I_2 = \frac{4/3}{S}$$

$$V_o = 3I_2 + (I_1 - I_3) \left[\frac{12S}{2S+3} \right] = \frac{4}{S} + \frac{2}{S} \left(\frac{12S}{2S+3} \right) = \frac{16S+6}{S(S+1.5)}$$

$$V_o = \frac{A}{S} + \frac{B}{S+1.5}$$

$$A = 4$$

$$B = 12$$

$$V_o(t) = (4 + 12e^{-3t/2})u(t)V$$

Problem 13.35

find $V_o(t), t > 0$ in the network.

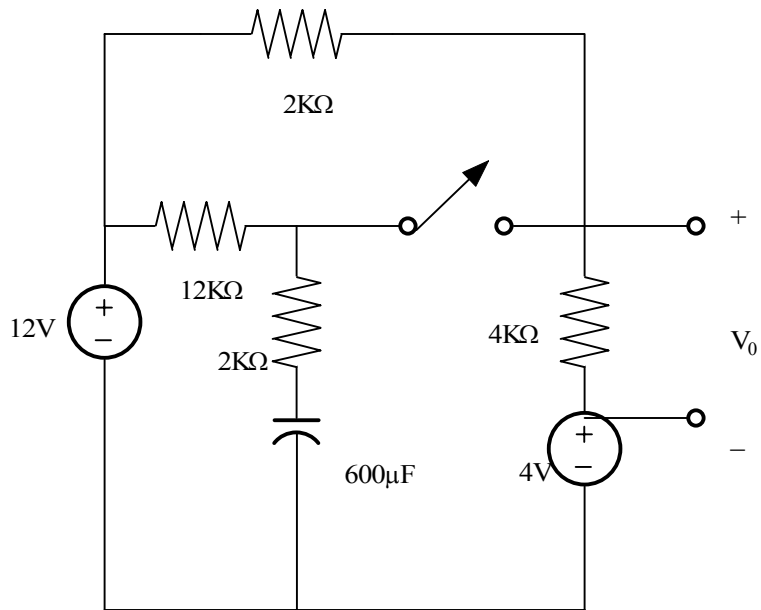

Suggested Solution

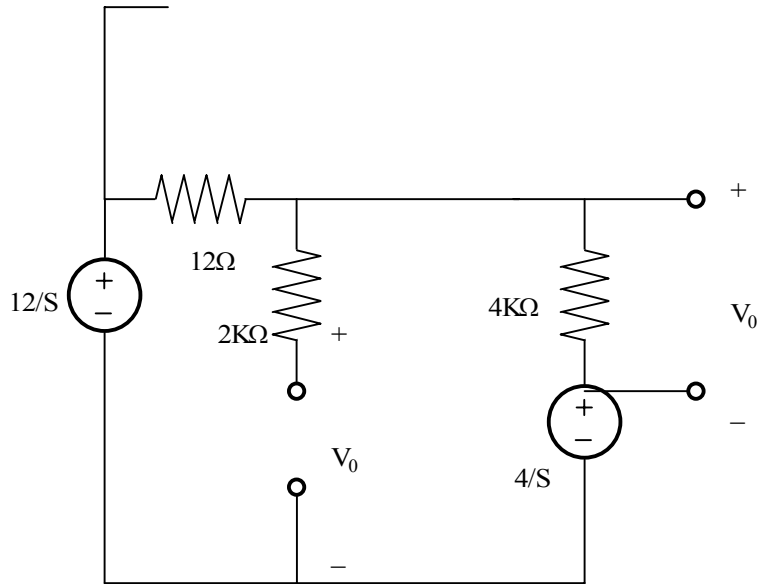

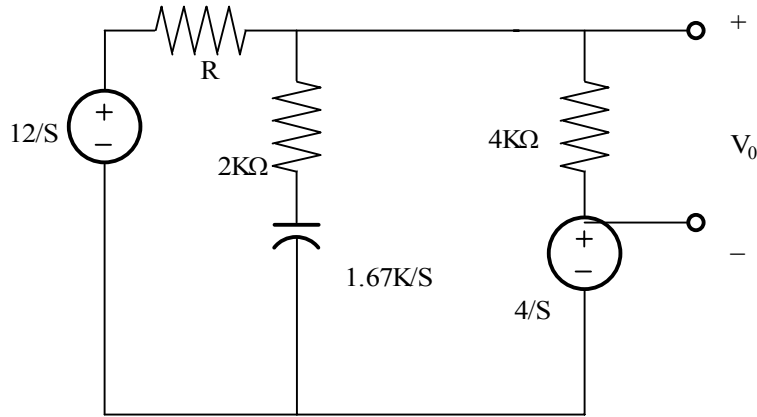

FOR $t > 0$

$$R = 6K \parallel 12K = 4K\Omega$$

$$V_1 = V_o + 4/S$$

KCL:

$$\frac{12}{S} - V_1 = \frac{V_1 - 12/S}{2K + \frac{1.67K}{S}} + \frac{V_o}{4K}$$

$$\frac{8}{S} - V_o = \frac{V_o - 8/S}{2K + \frac{1.67K}{S}} + \frac{V_o}{4K} \Rightarrow 8 = 2SV_o + \frac{4S^2V_o - 32S}{2 + \frac{5}{3S}}$$

OR,

$$8 = 2SV_o + \frac{4S^2V_o - 32S}{2S + \frac{5}{3}} \Rightarrow 8 = 2SV_o + \frac{12SV_o - 96S}{6S + 5}$$

$$V_o = \frac{6S + 5/3}{S(S + 5/12)} = \frac{A}{S} + \frac{B}{S + 5/12}$$

$$A = 4$$

$$B = 2$$

$$V_o(t) = (4 + 2e^{-5t/12})u(t)V$$

Problem 13.36

find $V_o(t), t > 0$ in the network.

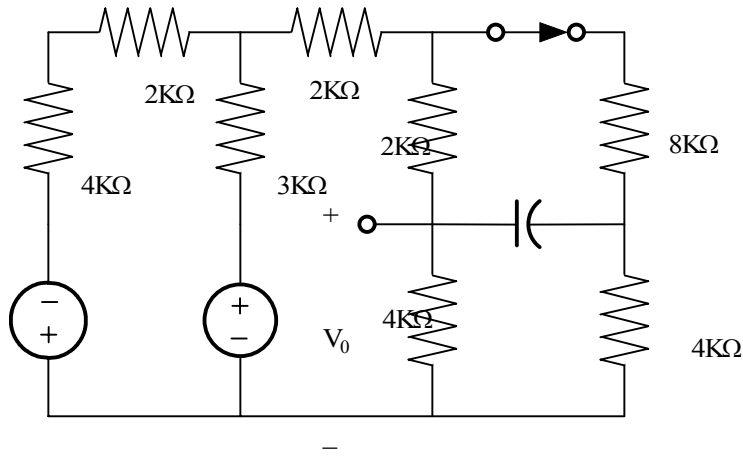

Suggested Solution

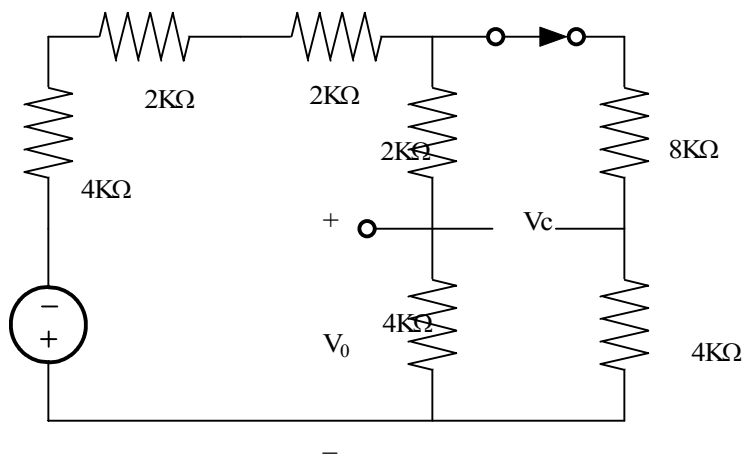
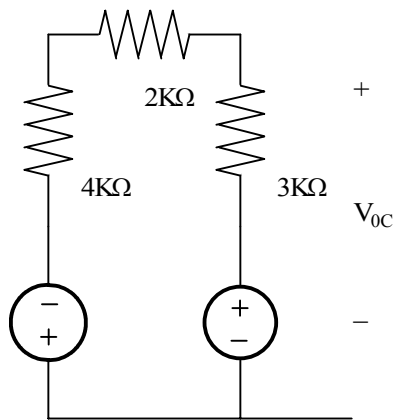

$$V_{oc} = 24 \frac{6K}{9K} - 12 \frac{3K}{9}$$

$$V_{oc} = 12V$$

$$R_{TH} = 3K \parallel 6K = 2K$$

$$V = 12(4K / 8K) = 6V$$

$$V_c = V \{ (4/6) - (4/12) \}$$

$$V_c = 2V$$

NODAL ANALYSIS:

$$\frac{12}{S} - V_o = \frac{V_o}{4K} + \frac{V_o - 2/S}{4K + 10K/S}$$

$$\frac{12 + SV_o}{6} = \frac{SV_o}{4} + \frac{S^2V_o - 2S}{4S + 10}$$

AND

$$24 - 2SV_o = \frac{6S^2V_o - 12S}{2S + S} + 3SV_o \Rightarrow -5SV_o + 24$$

$$6S^2V_o - 12S = -10S^2V_o - 25SV_o + 48S + 120$$

$$V_o[16S^2 + 25S] = 60S \Rightarrow V_o = \frac{A}{S} + \frac{B}{S + 24/16}$$

$$A = 24/5$$

$$B = -21/20$$

$$V_o(t) = \left(\frac{24}{5} - \frac{21}{20} e^{-25t/16} \right) u(t) V$$

Problem 13.37

find $V_o(t), t > 0$ in the network.

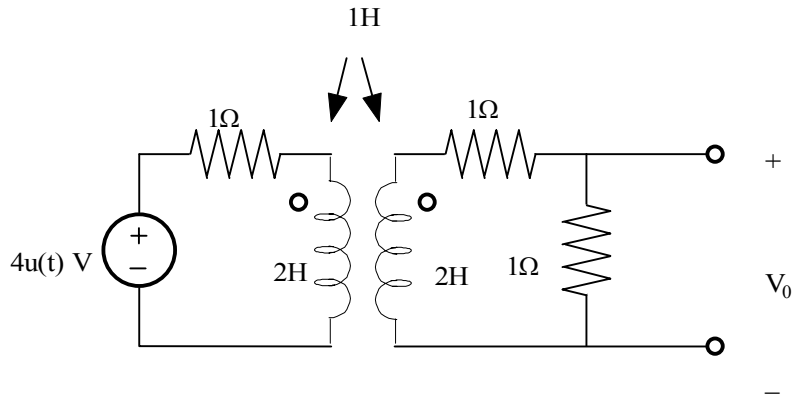

Suggested Solution

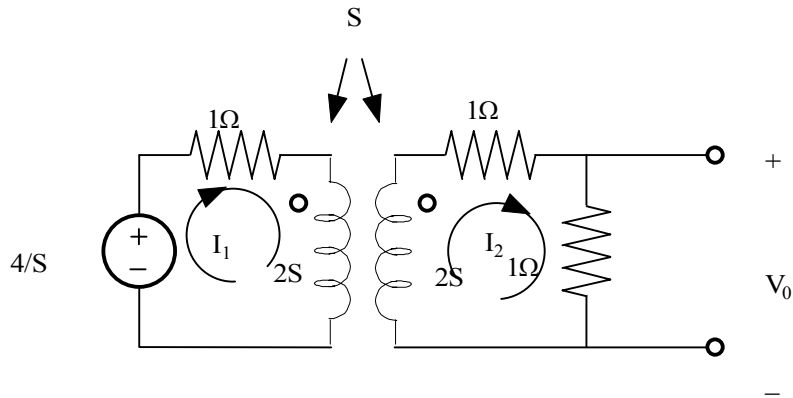

$$\frac{4}{S} = I_1(2S+1) - SI_2$$

$$0 = -SI_1 + I_2(2S+2) \Rightarrow I_1 = I_2((2S+2)/S)$$

SOLVING THE ABOVE TWO EQUATIONS WE GET:

$$\frac{4}{S} = I_2 \left[\frac{(2S+1)(2S+2)}{S} - S \right] \Rightarrow I_2 = \frac{4}{3S^2 + 6S + 2} \text{ \& } V_o = (1)I_2$$

$$V_o = \frac{4}{3S^2 + 6S + 2} = \frac{A}{S+0.42} + \frac{B}{S+1.58}$$

$$A = 1.15$$

$$B = -1.15, V_o(t) = 1.15[e^{-0.42t} - e^{-1.58t}]u(t) \text{ V}$$

Problem 13.38

find $V_o(t), t > 0$ in the network.

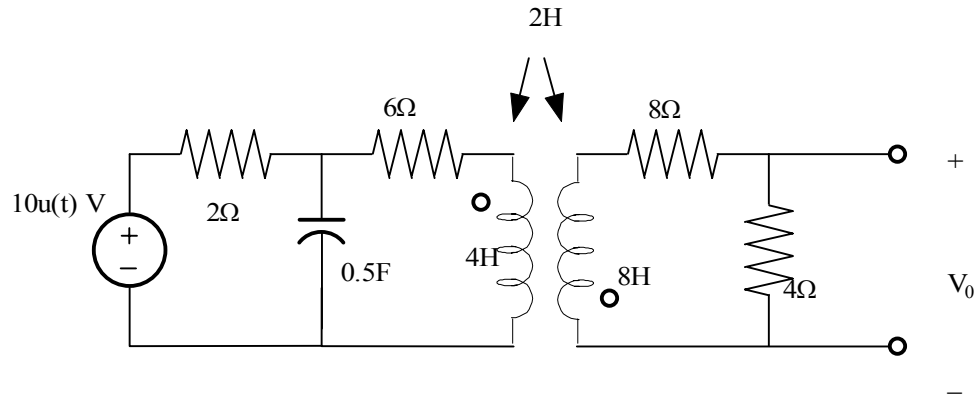

Suggested Solution

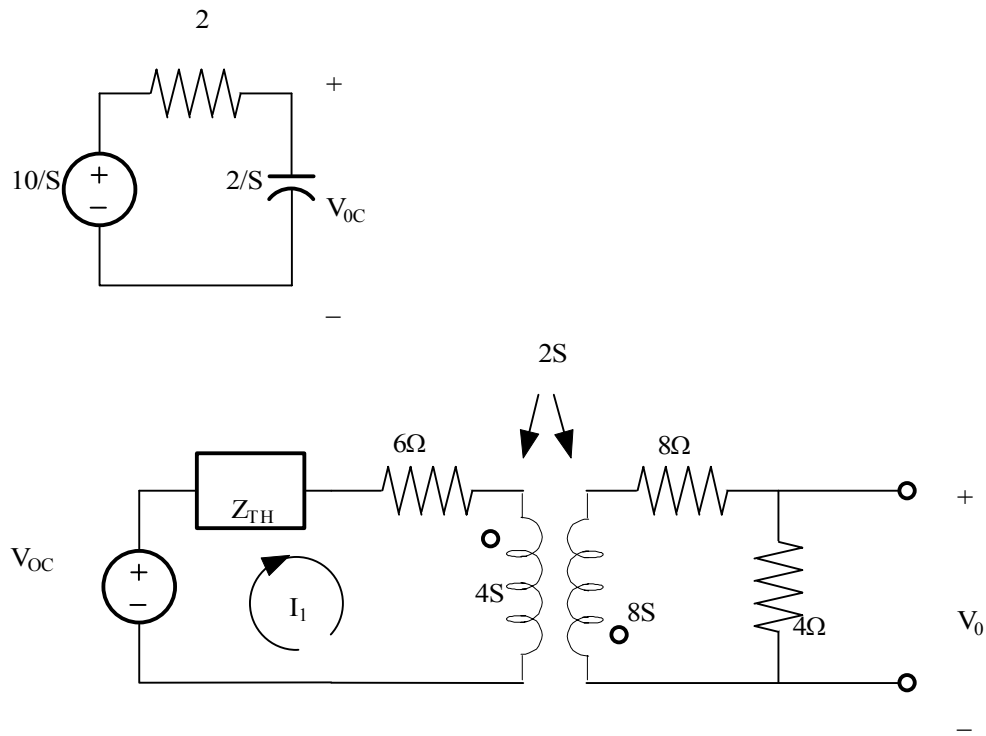

$$VOC = I_1(Z_{TH} + 6 + 4S) + 2SI_2 \text{ \& } 0 = 2SI_1 + I_2(8S + 12)$$

FROM THE SECOND LOOP EQUATION, $I_1 = \frac{(-4S+6)}{S}I_2$, AND,

$$V_{oc} = \frac{10}{S(S+1)} = I_1[2S - \frac{4S+6}{S}(\frac{2}{S+1} + 6 + 4S)]$$

$$10 = I_2[2S^3 + 2S^2 - (4S+6)(2 + 6S + 6 + 4S^2 + 4S)]$$

$$I_2 = \frac{-5/7}{S^3 + 31/7S^2 + 46/7S + 24}$$

$$V_o = 4I_2$$

FROM A CRC MATH HANDBOOK,

$$V_o = \frac{A}{S+0.513} + \frac{K|\theta}{S+0.257-j1/2} + \frac{K|-\theta}{S+0.257+j1/2}$$

$$A = -9.05$$

$$K|\theta = 5.08|27.20^\circ$$

$$V_o(t) = -9.05e^{-0.513t} + 10.16e^{-0.257t} \text{COS}(0.5t + 27.20) \text{V}$$

Problem 13.39

find $V_o(t), t > 0$ in the network.

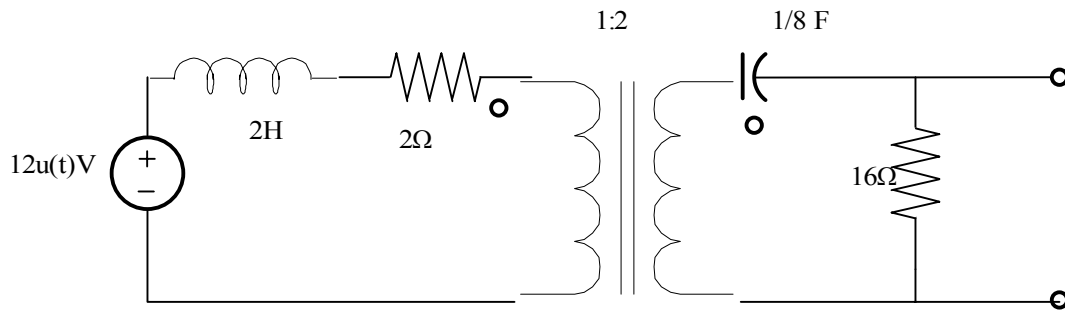

Suggested Solution

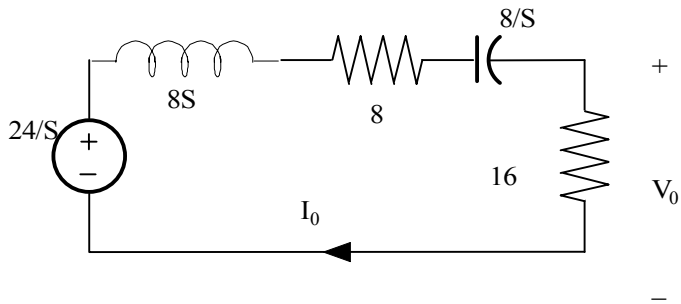
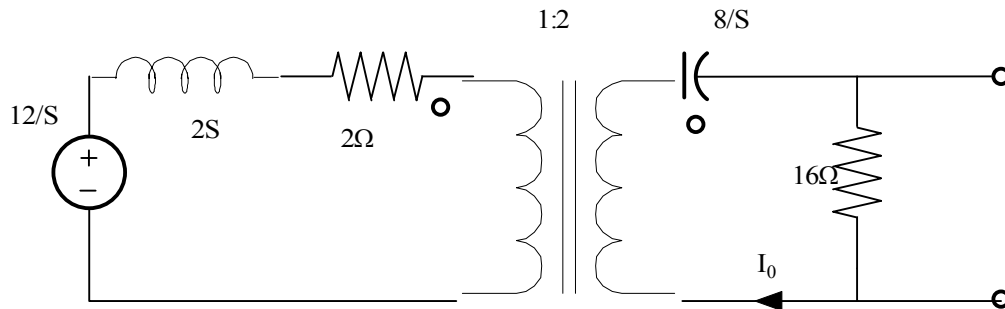

REFER PRIMARY TO SECONDARY , N=2

$$\frac{12}{S} \rightarrow N\left(\frac{12}{S}\right) = \frac{24}{S}$$

$$2S + 2 \rightarrow (2S + 2)N^2 = 8S + 8$$

$$I_o = \frac{\frac{24}{S}}{8S + 24 + 8/S} = \frac{3}{S^2 + 3S + 1}$$

$$I_o = \frac{A}{S + 0.38} + \frac{B}{S + 2.62}$$

$$A = 1.34$$

$$B = -1.34$$

$$i_o(t) = 1.34[e^{-0.38t} - e^{-2.62t}]u(t)V$$

Problem 13.40

find $V_o(t), t > 0$ in the network.

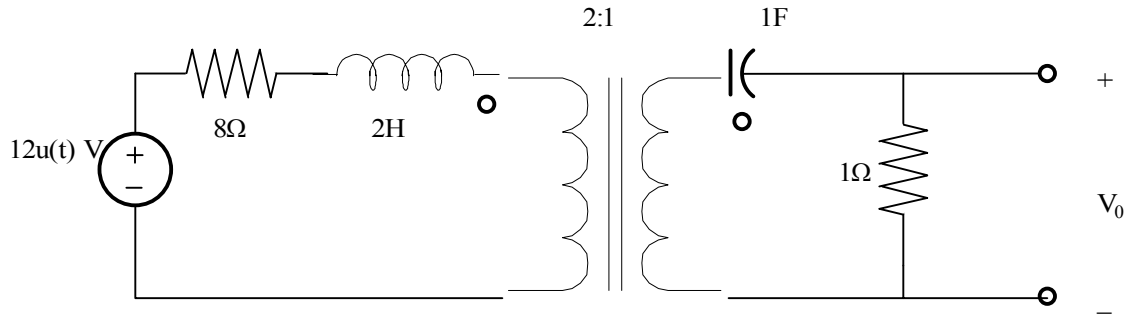

Suggested Solution

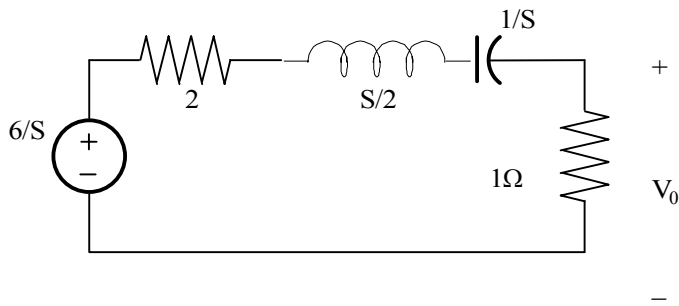
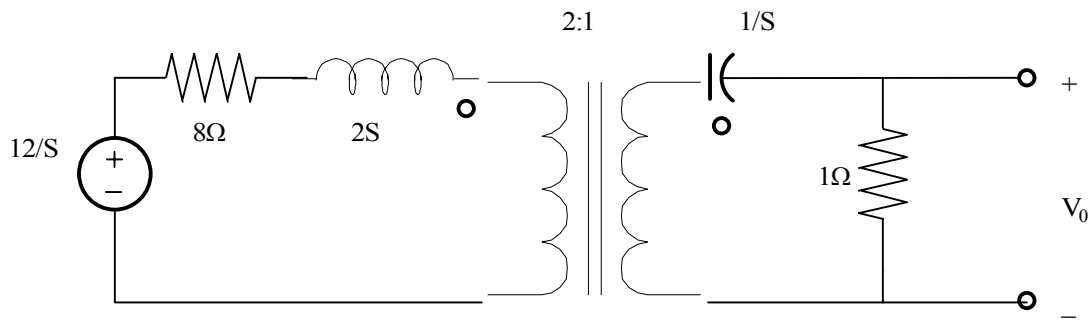

REFER PRIMARY TO SECONDARY , N=2

$$\frac{12}{S} \rightarrow N\left(\frac{12}{S}\right) = \frac{6}{S}$$

$$2S + B \rightarrow (2S + 8)N^2 = 0.5S + 2$$

$$V_o = \frac{\frac{6}{S}}{0.5S + 3 + 1/S} = \frac{12}{S^2 + 6S + 2}$$

$$V_o = \frac{A}{S + 0.35} + \frac{B}{S + 5.65}$$

$$A = 2.31$$

$$B = -2.31$$

$$V_o(t) = 2.31[e^{-0.35t} - e^{-5.65t}]u(t)V$$

Problem 13.41

find $V_o(t), t > 0$ in the network.

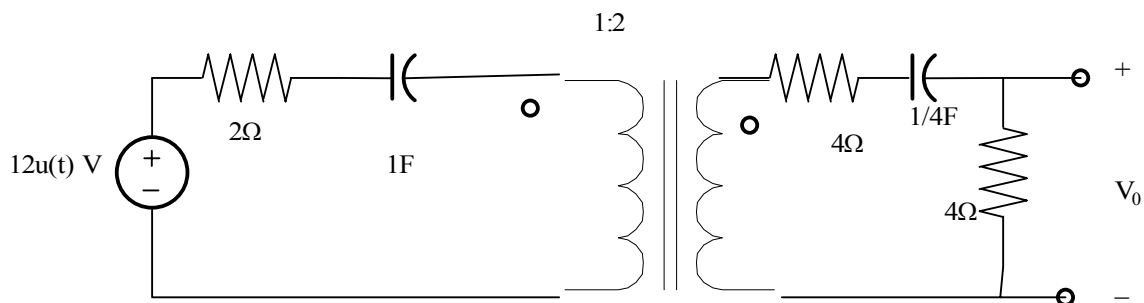

Suggested Solution

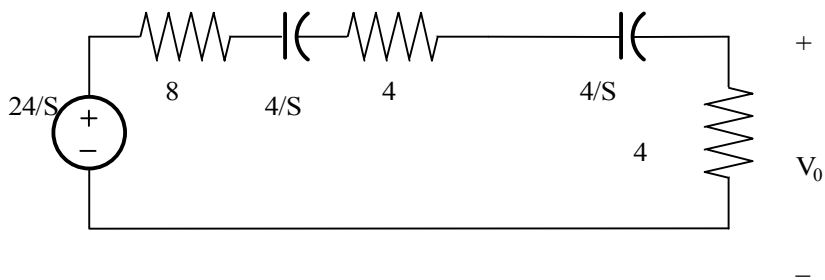
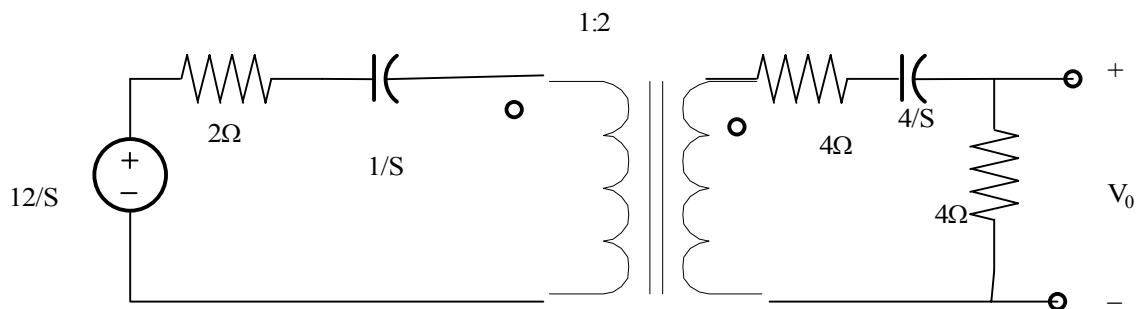

REFER PRIMARY TO SECONDARY , $N=2$

$$\frac{12}{S} \rightarrow N\left(\frac{12}{S}\right) = \frac{24}{S}$$

$$1/S + 2 \rightarrow (1/S + 2)N^2 = 4/S + 8$$

$$V_o = \frac{24}{S} \left(\frac{4}{16 + 8/S} \right)$$

$$V_o = \frac{96}{16S + 8} + \frac{6}{S + 0.5}$$

$$V_o(t) = e^{-t/2} V$$

Problem 13.42

Determine the output voltage $V_o(t)$ in the network in fig if the input is given by the source in fig.

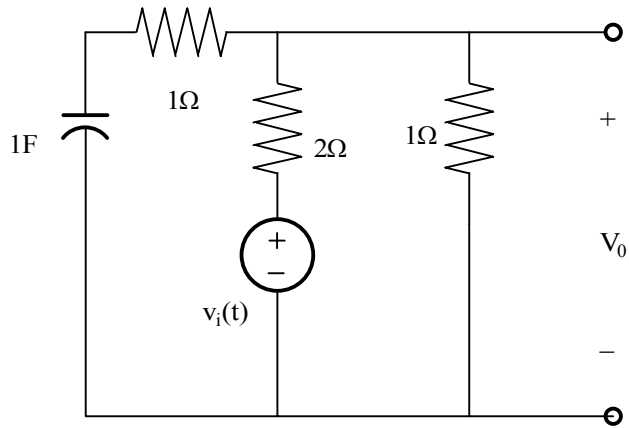

Suggested Solution

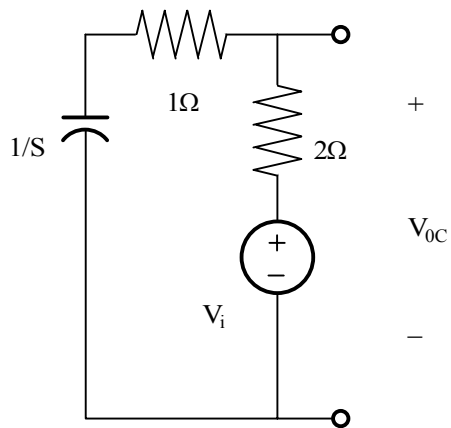
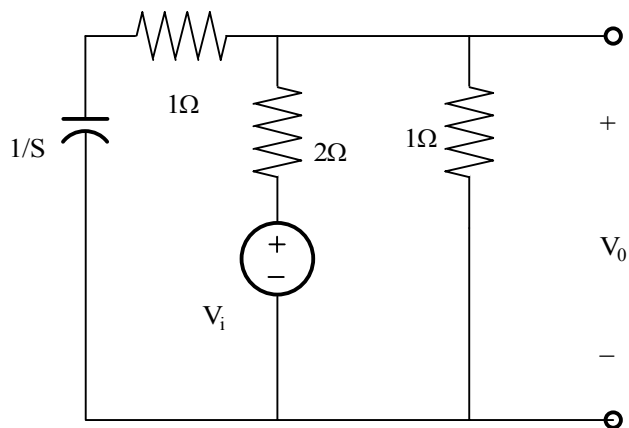

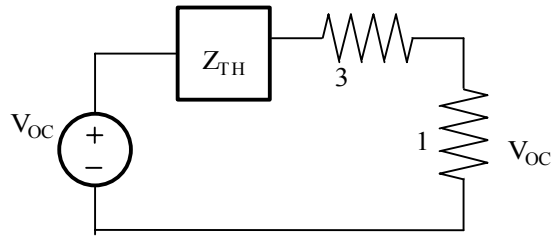

Therevin's EQ:

$$V_{oc} = V_i \left[1 - \frac{2}{3+1/S} \right] = V_i \left(\frac{S+1}{3S+1} \right)$$

NEW CIRCUIT:

$$V_o = V_{oc} \frac{1}{4+Z_{TH}}$$

$$V_o = V_i \left(\frac{S+1}{3S+1} \right) \left(\frac{3S+1}{12S+4+2S+2} \right)$$

$$V_o = \frac{(S+1)}{(14S+6)} \Rightarrow V_o = \frac{6(S+1)}{S(14S+6)} (1-e^{-s})$$

$$V_o = \left[\frac{A}{S} + \frac{B}{S+3/7} \right] (1-e^{-s})$$

$$A = 1$$

$$B = -4/7$$

$$V_o(t) = \left[1 - \frac{4}{7} e^{-3t/7} \right] u(t) V$$

Problem 13.43

find $V_o(t), t > 0$ in the network in fig if the input is represented by the waveform shown in fig.

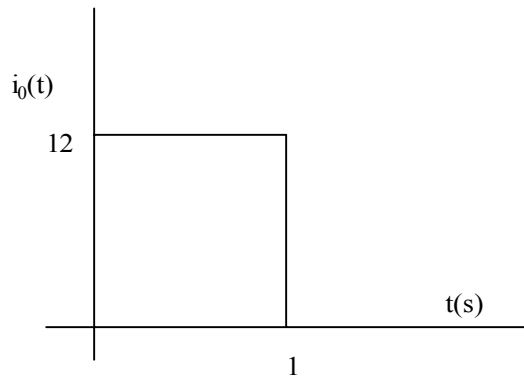
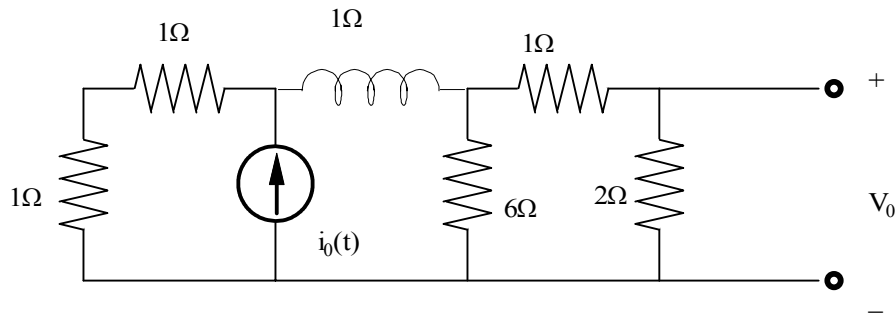

Suggested Solution

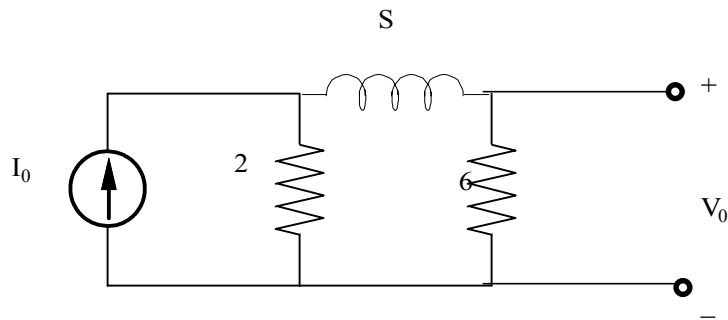

$$V_{oc} = 2I_o \left[\frac{6}{S+8} \right] = \frac{24}{S} + \left(\frac{6}{S+8} \right) = \left[\frac{144}{S(S+8)} \right] (1 - e^{-s})$$

$$Z_{TH} = 6 \parallel (S+2) = \frac{6S+12}{S+8}$$

NEW CIRCUIT:

$$V_o = V_{oc} \frac{2}{3+Z_{TH}} = V_{oc} \left[\frac{(S+8)2}{9S+36} \right]$$

$$V_o = \frac{32}{S(S+4)}$$

ADD THE TIMESHIFT TERM:

$$V_o = \frac{32}{S(S+4)} (1 - e^{-s}) = \left[\frac{A}{S} + \frac{B}{S+4} \right] (1 - e^{-s})$$

$$A = 8$$

$$B = -8$$

$$V_o(t) = [8 - 8e^{-4(t-1)}] u(t-1) V$$

Problem 13.44

Determine the output voltage $V_o(t)$ in the network in fig if the input is given by the source in fig.

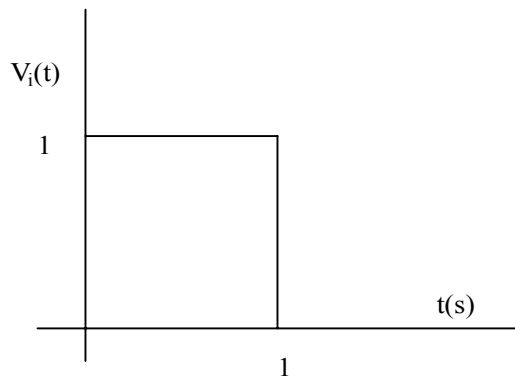
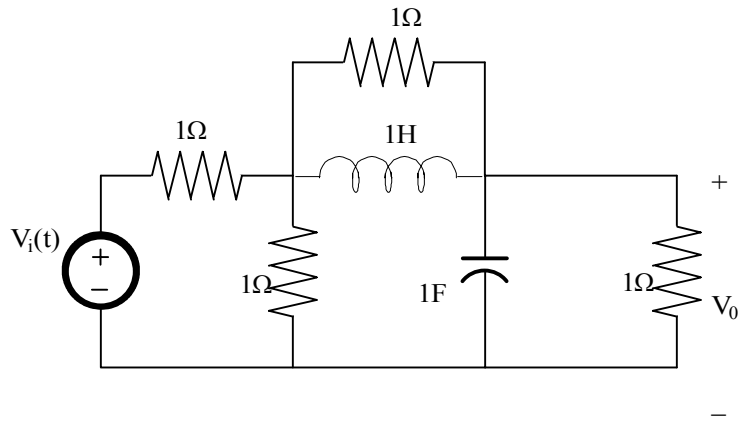

Suggested Solution

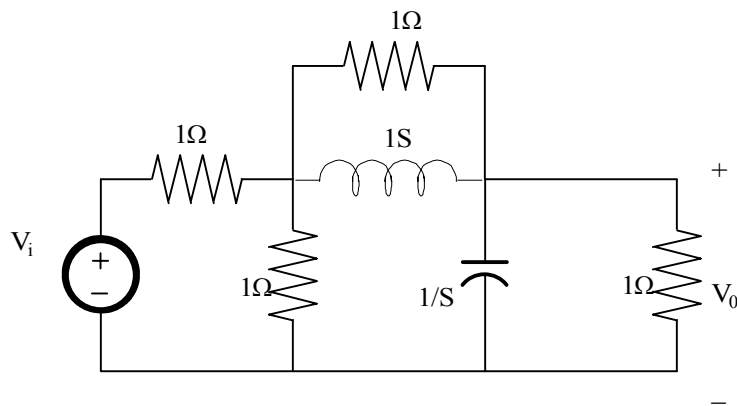

$$V_i(t) = 1[u(t) - u(t-1)]$$

$$V_i(S) = \frac{1}{S}(1 - e^{-S})$$

$$V_o = \frac{V_1}{2} \left[\frac{\frac{1}{S+1}}{0.5 + \frac{1}{S+1} + \frac{S}{S+1}} \right] = \frac{V_1}{2} \left[\frac{1}{S+1 + \frac{S}{2} + \frac{1}{2}} \right] = \frac{V_1/3}{S+1}$$

$$V_o = \frac{1}{3} \left(\frac{1}{S(S+1)} \right) (1 - e^{-S}) = \left[\frac{A}{S} + \frac{B}{S+1} \right] (1 - e^{-S})$$

$$A = 1/3$$

$$B = -1/3$$

$$V_o(t) = \left[\frac{1}{3} - \frac{1}{3} e^{-t} \right] u(t) - \left[\frac{1}{3} - \frac{1}{3} e^{-(t-1)} \right] u(t-1)$$

Problem 13.45

Find the transfer function $V_o(s)/V_i(s)$ for the network shown in fig.

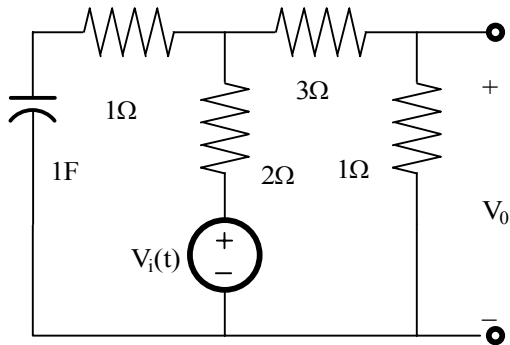

Suggested Solution

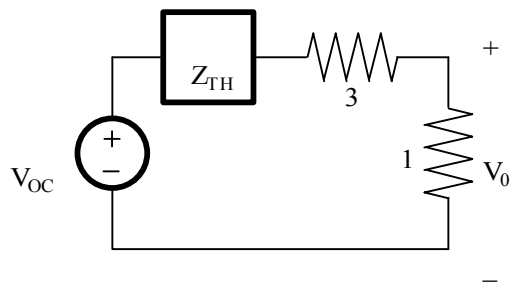
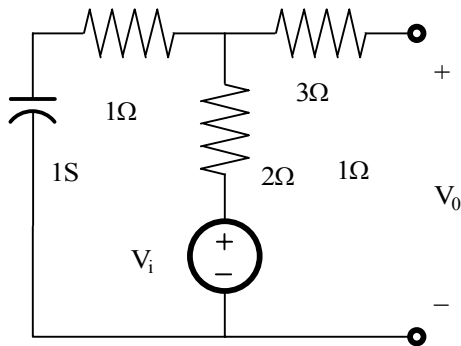

$$V_{oc} = V_i \left[1 - \frac{2}{3 + 1/S} \right] = V_i \left(\frac{S+1}{3S+1} \right)$$

$$Z_{TH} = 2 \parallel \left(\frac{1}{S} + 1 \right) = \frac{2S+2}{3S+1}$$

$$V_o = V_{oc} \frac{1}{4 + Z_{TH}}$$

$$\frac{V_o}{V_i} = \frac{S+1}{14S+6}$$

Problem 13.46

Find the transfer function $V_o(s)/V_i(s)$ for the network shown in fig.

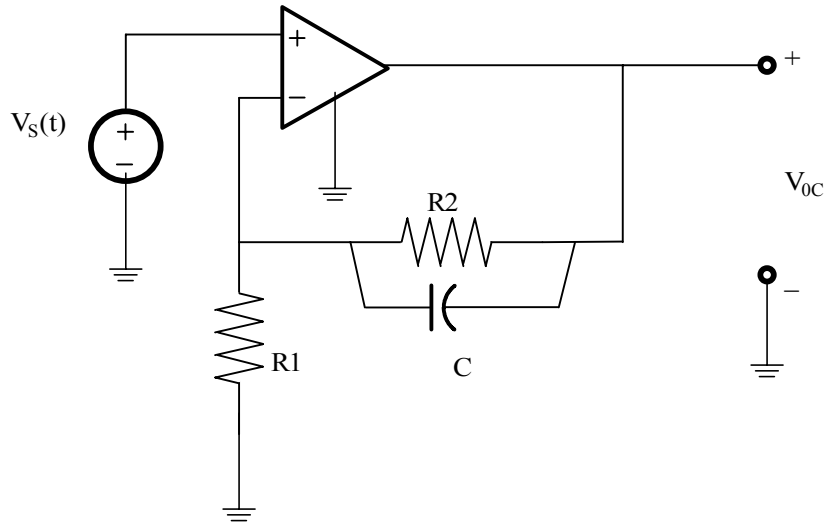

Suggested Solution

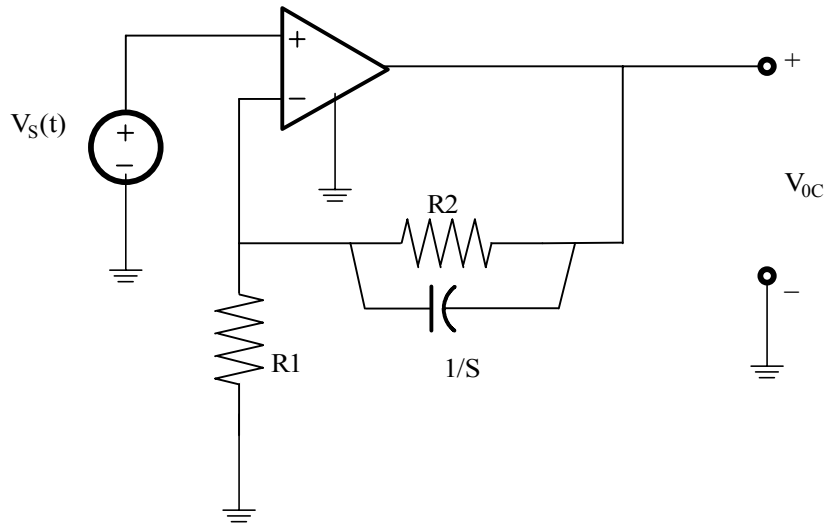

$$\frac{V_o - V_s}{Z} = \frac{V_s}{R_2} \Rightarrow \frac{V_s}{V_o} = 1 + \frac{Z}{R_2}$$

$$Z = R_1 \parallel \frac{1}{sC} = \frac{R_1}{1 + sCR_1}$$

$$\frac{V_o}{V_s} = \left(1 + \frac{R_1}{R_2}\right) \left(\frac{1 + sCR_1}{1 + sCR_1}\right);$$

$$R = R_1 \parallel R_2$$

NOTE THAT THE $1 + R_1/R_2 = \text{dC GAIN}$.

Problem 13.47

Find the transfer function $V_o(s)/V_i(s)$ for the network shown in fig.

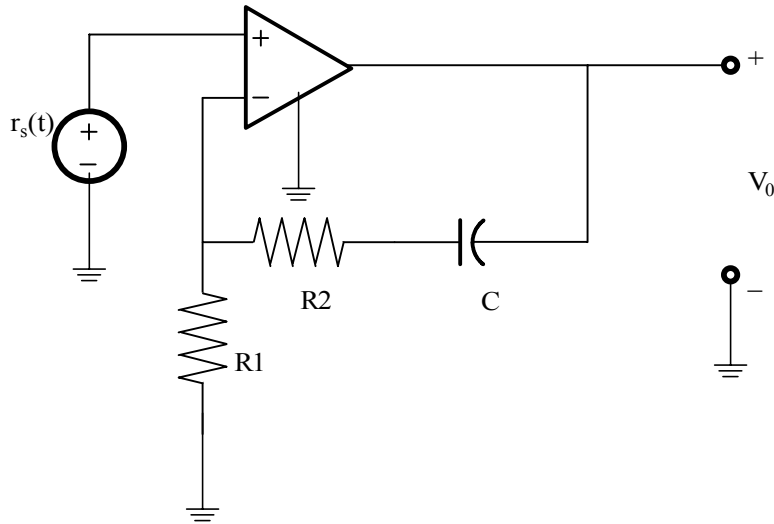

Suggested Solution

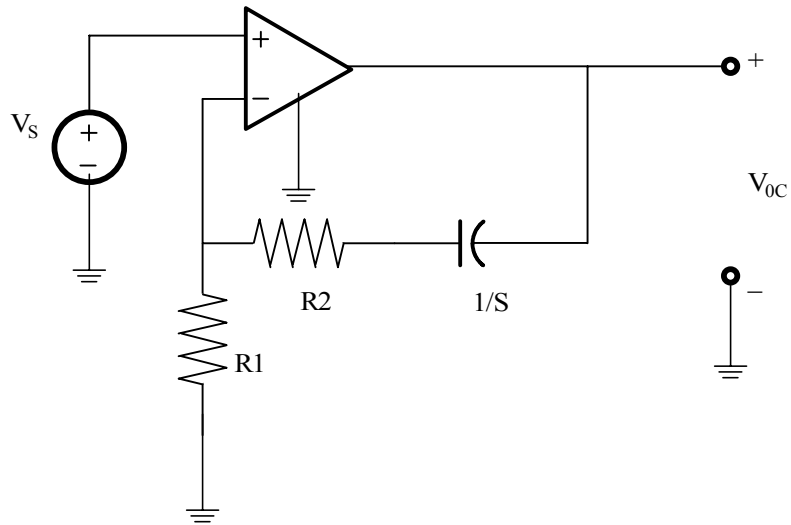

$$\frac{V_o - V_s}{R_1 + 1/SC} = \frac{V_s}{R_2} \Rightarrow \frac{V_o}{V_s} = 1 + \frac{R_1 + 1/SC}{R_2}$$

OR,

$$\frac{V_o}{V_s} = \left(1 + \frac{R_1}{R_2}\right) + \frac{1}{SCR_2} = \left(1 + \frac{R_1}{R_2}\right) \left(1 + \frac{1}{SCR}\right);$$

$$R = R_1 + R_2$$

$$\frac{V_o}{V_s} = \left(1 + \frac{R_1}{R_2}\right) \left(1 + \frac{1}{SCR}\right)$$

NOTE THAT THE $1 + R_1/R_2 = \text{GAIN AT } S \rightarrow \infty$

Problem 13.48

Find the transfer function $V_o(s)/V_i(s)$ for the network shown in fig.

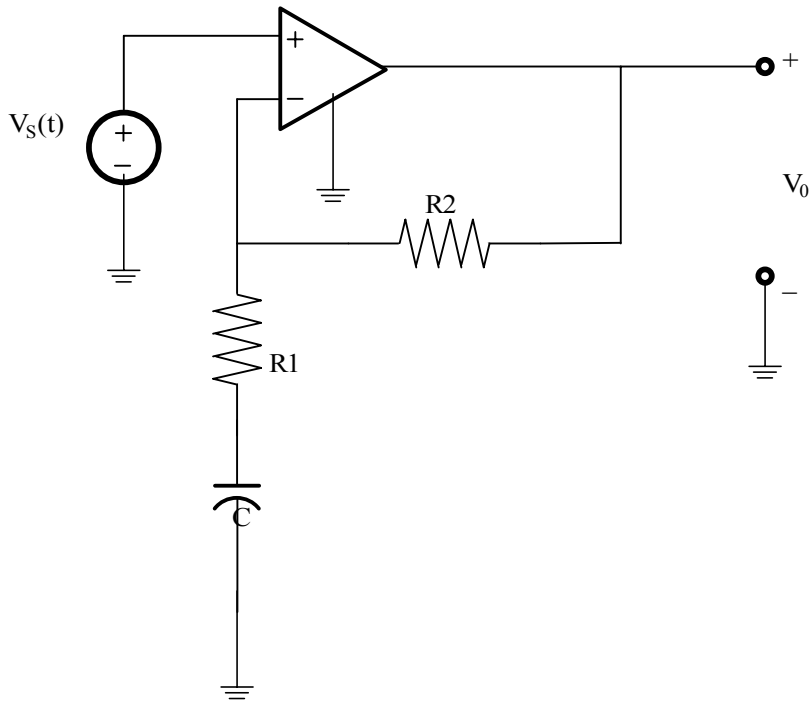

Suggested Solution

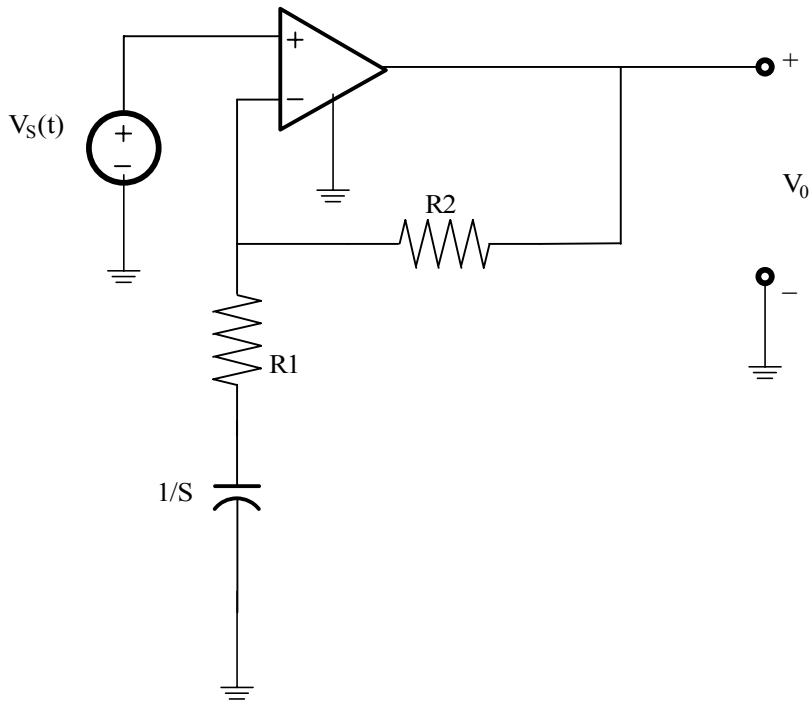

$$\frac{V_o - V_s}{R_1} = \frac{V_s}{R_2 + 1/SC} \Rightarrow \frac{V_o}{V_s} = 1 + \frac{R_1}{R_2 + 1/SC}$$

OR,

$$\frac{V_o}{V_s} = 1 + \left(\frac{SCR_1}{1 + SCR_2} \right);$$

FINALLY,

$$\frac{V_o}{V_s} = \left(1 + \frac{R_1}{R_2} \right) \left(\frac{S + 1/(C(R_1 + R_2))}{S + \frac{1}{CR_2}} \right)$$

NOTE THAT THE $1 + R_1/R_2 =$ HIGH FREQUENCY GAIN

Problem 13.49

Find the transfer function $V_o(s)/V_i(s)$ for the network shown in fig.

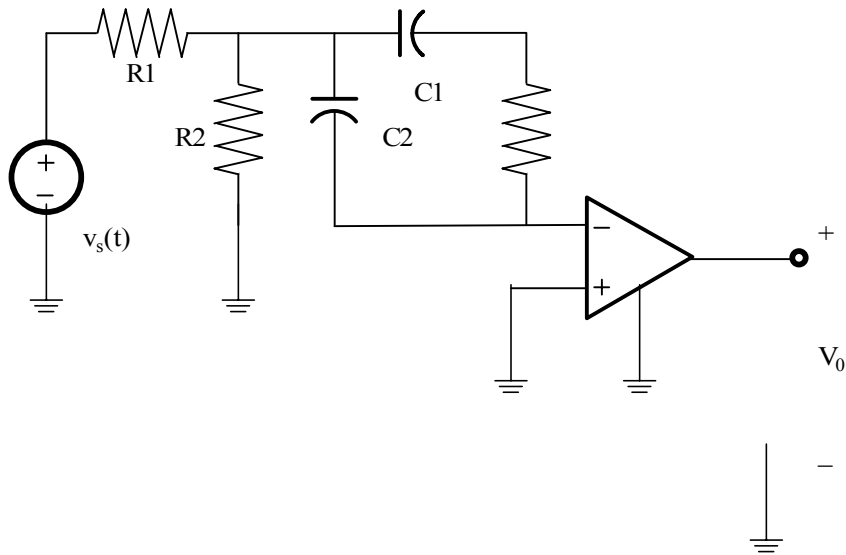

Suggested Solution

KCL AT NODE V_1 IS

$$\frac{V_s - V_1}{R_1} = \frac{V_1}{R_2} + SC_2V_1 + C_1S(V_1 - V_o)$$

AT THE -VE TERMINAL OF THE OP-AMP SINCE

$$i_- = 0 \quad \therefore SC_2V_1 + \frac{V_o}{R_3} = 0$$

SOLVING THE TWO EQUATIONS YIELDS:

$$\frac{V_o}{V_s} = \frac{\frac{-S}{C_1R_1}}{S^2 + S\left(\frac{C_1}{C_1C_2R_3} + \frac{C_2}{C_1C_2R_3}\right) + \frac{R_1 + R_2}{C_1C_2R_1R_2R_3}}$$

Problem 13.50

Determine the transfer function for the network shown in fig. If a step function is applied to the network What type of damping will the network exhibit.

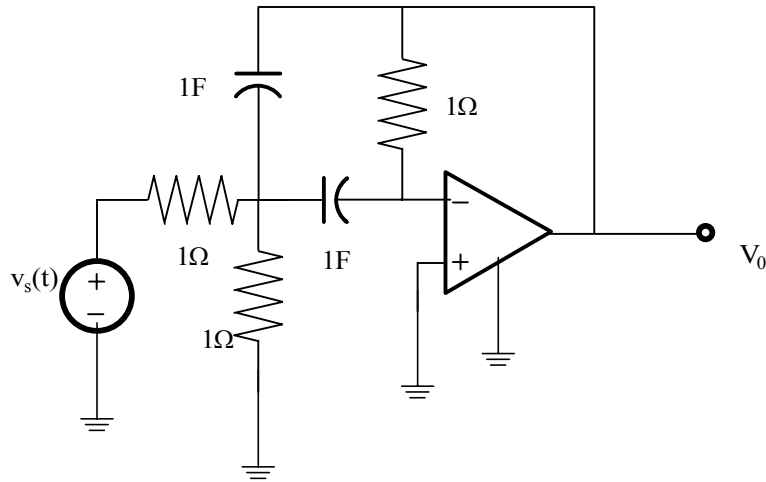

Suggested Solution

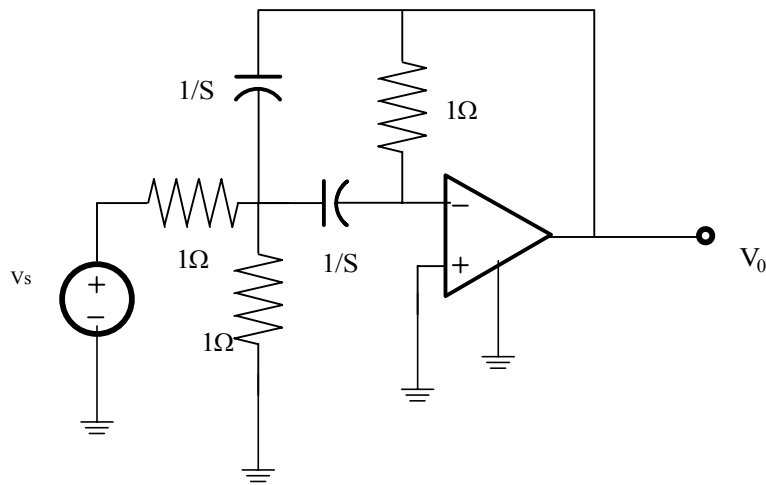

USING KCL:

$$\text{AT } V_1: V_s - V_1 = V_1 + (V_1 - V_o)S + SV_1$$

$$\text{OR, } V_s = V_1(2S+2) - V_o(S)$$

$$\text{AT (-) INPUT: } SV_1 = -V_o \Rightarrow V_1 = -V_o/S$$

NOW,

$$V_s = \frac{V_o}{S}(2S+2) - SV_o = V_o(S+2+2/S) \Rightarrow -\frac{V_o}{V_s} = \frac{S}{S^2+2S+2}$$

CHARACTERISTIC EQ: S^2+2S+2

ROOTS ARE $S = -1 \pm j1$

Problem 13.51

Find the transfer function $V_o(s)/V_i(s)$ for the network shown in fig. If the step function is applied to the network, will the response be overdamped, underdamped, or critically damped.

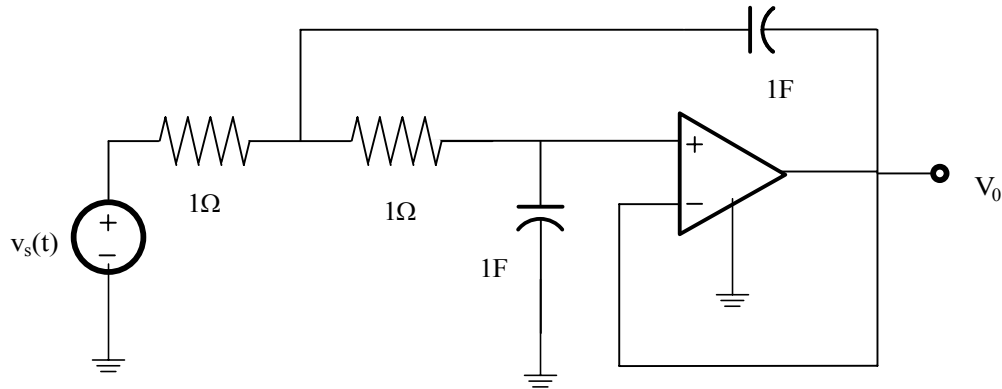

Suggested Solution

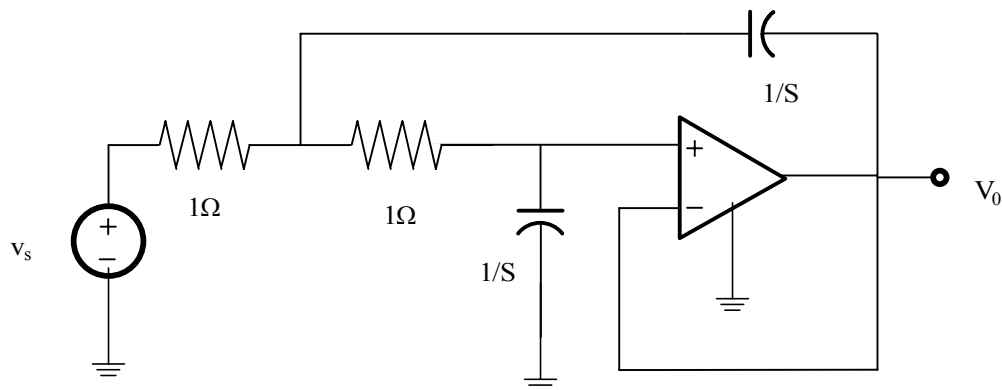

NODAL ANALYSIS,

$$\text{@ } V_1: \frac{V_s - V_1}{1} = (V_1 - V_o)S + \frac{(V_1 - V_o)}{1}$$

$$V_s = V_1(S + 2) - V_o(S + 1)$$

$$\text{@ } (+) \text{ INPUT: } \frac{V_1 - V_o}{1} = (V_o)S \Rightarrow V_1 = V_o(S + 1)$$

$$V_s = V_o[(S + 1)(S + 2) - 1] = V_o(S + 1)(S + 1) = V_o(S + 1)^2$$

$$\frac{V_o}{V_s} = \frac{1}{(S + 1)^2}$$

CRITICALLY DAMPED.

Problem 13.52

The voltage response of the network to a unit step input is.

$$V_0(s) = \frac{2(s+1)}{s(s^2+12s+27)}$$

Is the response overdamped.

Suggested Solution

A Network has a step response of

$$V_0(s) = \frac{2(s+1)}{s(s^2+12s+27)}$$

is it overdamped?

completing the square

$$s^2 + 12s + 27 = (s+3)(s+9)$$

$$\therefore s = -3, s = -9$$

system is overdamped.

Problem 13.53

The transfer function of the network is given by the expression

$$G(s) = \frac{100s}{s^2 + 22s + 40}$$

Determine the damping ratio, the underdamped natural frequency and the type of response that will be exhibited by the network.

Suggested Solution

A system has the transfer function

$$G(s) = \frac{100s}{s^2 + 22s + 40}$$

find

ξ, ω_0

The characteristic equation

$$s^2 + 22s + 40 = 0$$

with analogy to

$$s^2 + 2\xi\omega_0s + \omega_0^2$$

$$\omega_0 = \sqrt{40}, 2\xi\omega_0 = 22$$

$$\xi = \frac{11}{2\sqrt{10}}$$

overdamped

Problem 13.54

The current response of a network to a unit step input is

$$I_0(s) = \frac{10(s+2)}{s^2(s^2+11s+30)}$$

Is the response underdamped?

Suggested Solution

If step response is

$$I_0(s) = \frac{10(s+2)}{s^2(s^2+11s+30)}$$

How is it Damped?

The characteristic equation is

$$s^2(s^2+11s+30) = 0$$

$$s^2(s+6)(s+5)$$

Roots

$$s = -6, s = -5$$

Being real and unequal it is overdamped.

Problem 13.55

The voltage response of a network to a unit step input is

$$V_0(s) = \frac{10}{s(s^2 + 8s + 16)}$$

Is the response critically damped.

Suggested Solution

If step response is

$$V_0(s) = \frac{10}{s(s^2 + 8s + 16)}$$

The characteristic equation is

$$(s^2 + 8s + 16) = 0$$

$$(s + 4)^2 = 0$$

Roots

$$s = -4$$

Critically Damped.

Problem 13.56

For the network in fig choose the value of C for critical damping.

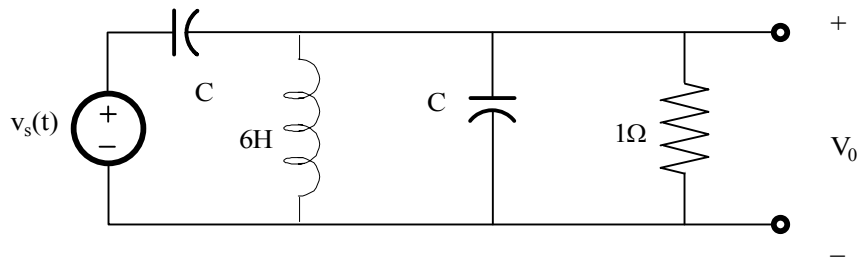

Suggested Solution

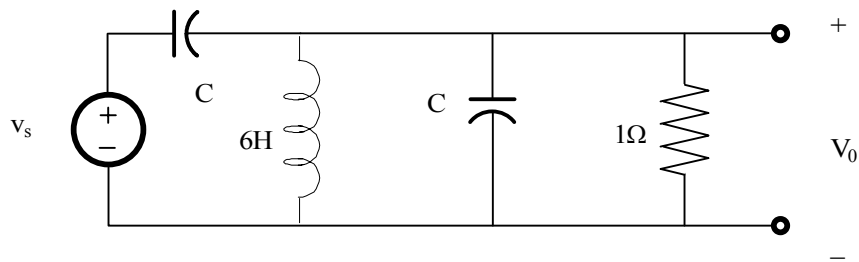

Parallel RLC Circuit

$$R = 1\Omega, L = 6h, C_{eq} = C + 1F;$$

Characteristic Equation is

$$s^2 + \frac{s}{RC_{eq}} + \frac{1}{LC_{eq}} = 0$$

$$s^2 + 2\xi\omega_n s + \omega_n^2 = 0$$

For critical damping, $\xi = 1$

$$\omega_n = \frac{1}{\sqrt{LC_{eq}}} = \frac{1}{\sqrt{6C_{eq}}}$$

$$RC_{eq} = C_{eq} = \frac{1}{2\omega_n} = \frac{\sqrt{6}}{2} C_{eq}$$

$$\sqrt{C_{eq}} = \frac{\sqrt{6}}{2}$$

$$C_{eq} = \frac{6}{4} = 1.5 = C + 1$$

$$C = 0.5F$$

Problem 13.57

For the filter in fig choose the values of c_1 and c_2 to place poles at $s=-2$ and $s=-5$ rad/s.

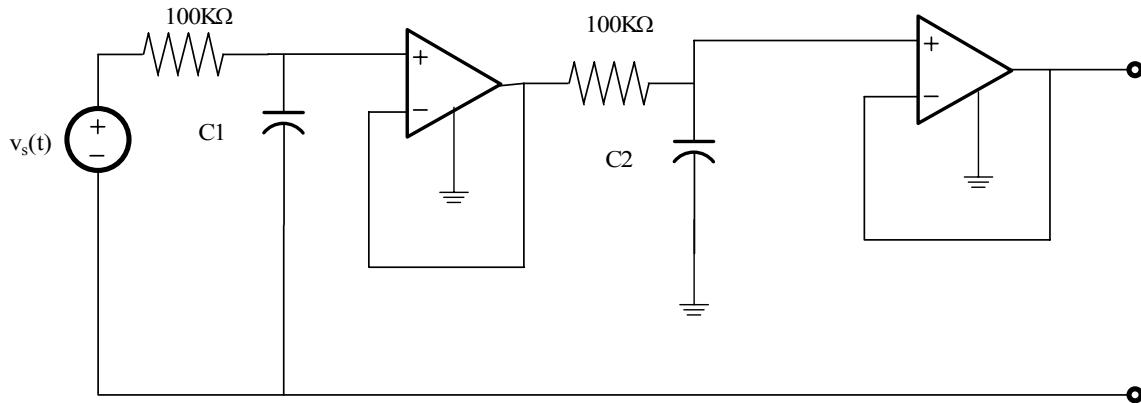

Suggested Solution

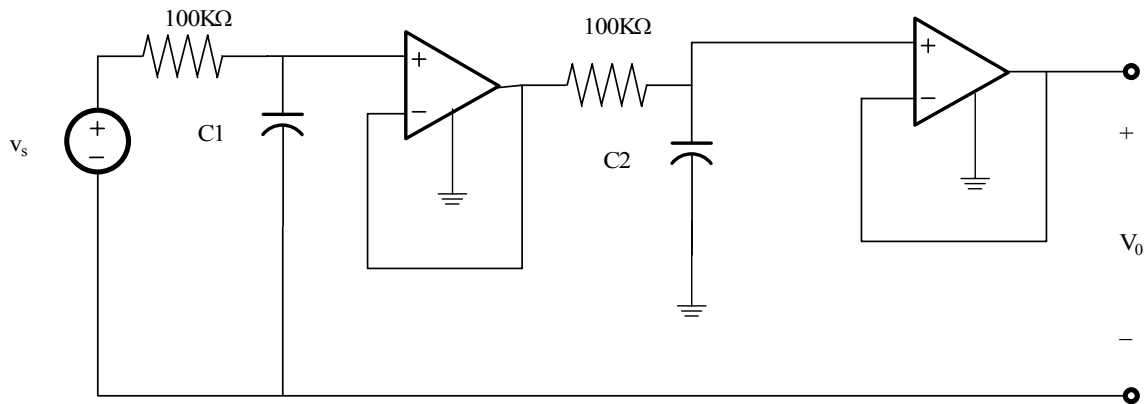

Both opamps are connected as unity gain buffers

$$R = 100k\Omega$$

$$V_1 = V_s \left(\frac{1/sc_1}{1/sc_1 + R} \right)$$

also

$$V_0 = V_1 \left(\frac{1/sc_2}{R + 1/sc_2} \right)$$

or

$$\frac{V_0}{V_s} = \frac{1}{R^2 c_1 c_2} \left[\frac{1}{\left(s + \frac{1}{Rc_1}\right) \left(s + \frac{1}{Rc_2}\right)} \right]$$

For poles at -2 and -5

the transfer function is

$$\frac{V_o}{V_s} = \frac{1}{R^2 c_1 c_2} \left[\frac{1}{(s+2)(s+5)} \right]$$

so

$$Rc_1 = 0.5$$

$$Rc_2 = 0.2$$

$$c_1 = 5\mu F$$

$$c_2 = 2\mu F$$

c_1 and c_2 interchangeable

Problem 13.58

Find the steady state response $V_o(t)$ for the network in fig.

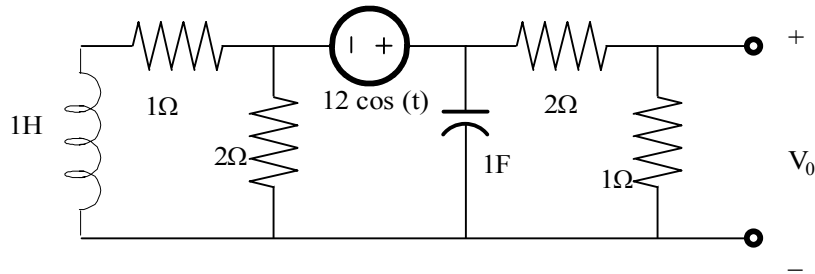

Suggested Solution

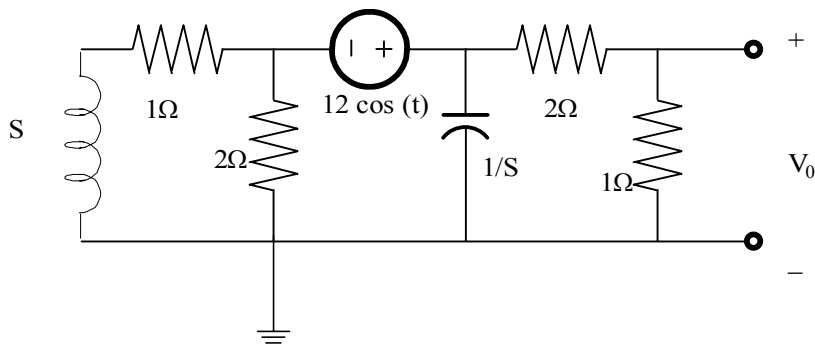

Using KCL

$$\frac{V_1}{s+1} + \frac{V_2}{2} + \frac{V_2}{1/s} + \frac{V_2}{3} = 0$$

$$V_1 = V_2 - V_i$$

$$V_i(t) = 12 \cos(t) V$$

$$V_2 \left(\frac{1}{s+1} + \frac{1}{2} + s + \frac{1}{3} \right) = V_i \left(\frac{1}{s+1} + \frac{1}{2} \right)$$

Solve for the Transfer Function

$$\frac{V_2}{V_i} = \frac{3s+9}{6s^2+11s+11}$$

$$\frac{V_o}{V_i} = \frac{V_2}{3/V_i} = \frac{s+3}{6s^2+11s+11}$$

For Steady State $s = j1$

$$\left. \frac{V_o}{V_i} \right|_{j1} = \frac{3+j1}{-6+11+j11} = 0.26 \angle -47.2^\circ$$

Also

$$|V_{in}| = 12$$

so

$$V_0 = 12(0.26) - 47.2^\circ$$

Steady State Phasor

$$V_0(t) = 3.13 \cos(t - 47.2^\circ) V$$

Problem 13.59

Find the steady state response $V_o(t)$ for the network in fig.

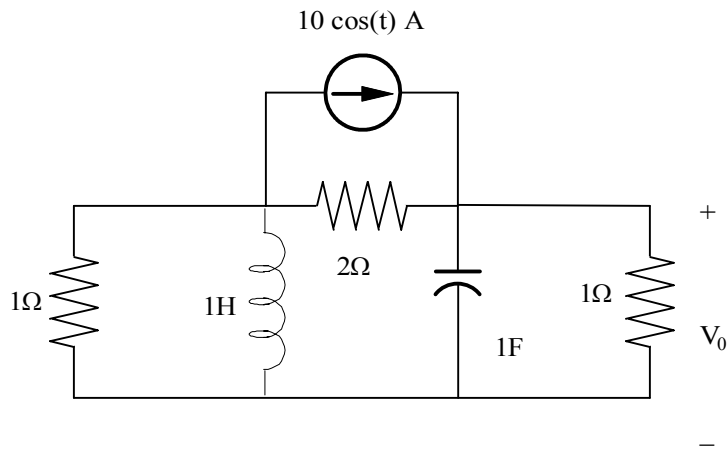

Suggested Solution

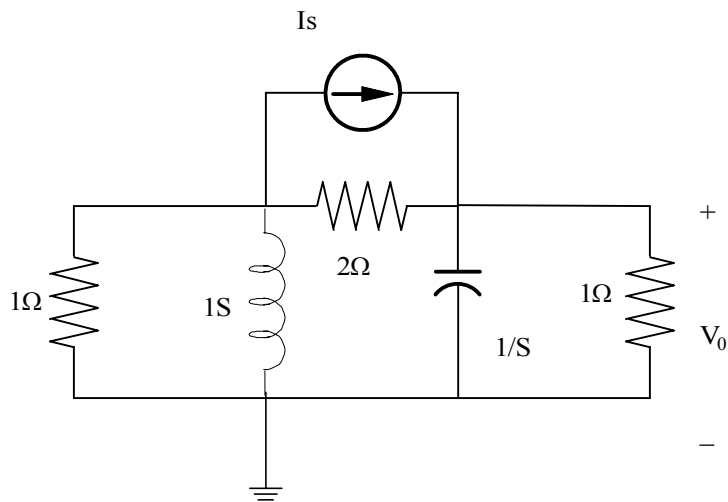

Nodal Analysis

$$\frac{V_1}{1} + \frac{V_1}{s} + V_2(s) + \frac{V_2}{1} = 0$$

$$V_1\left(1 + \frac{1}{s}\right) = -V_2(s+1)$$

or

$$V_1 = -sV_2$$

$$I_s + \frac{V_1 - V_2}{2} = V_2s + V_2$$

$$V_1 = V_2(2s + 3) - 2I_s$$

$$-sV_2 = V_2(2s + 3) - 2I_s$$

$$V_2 = V_0 = I_s \left(\frac{2}{3s + 3} \right)$$

Transfer Function

$$\frac{V_0}{I_s} = \frac{2/3}{s + 1}$$

For steady state $s = j1$ and

$$\frac{V_0}{I_s} = \frac{2/3}{1 + j1} = \frac{\sqrt{2}}{3} \angle -45^\circ$$

$$|I_s| = 10$$

so,

$$V_0 = \frac{10\sqrt{2}}{3} \angle -45^\circ$$

$$V_0(t) = 4.7 \cos(t - 45^\circ) V$$

Problem 13.60

Find the steady state response $V_o(t)$ for the network in fig.

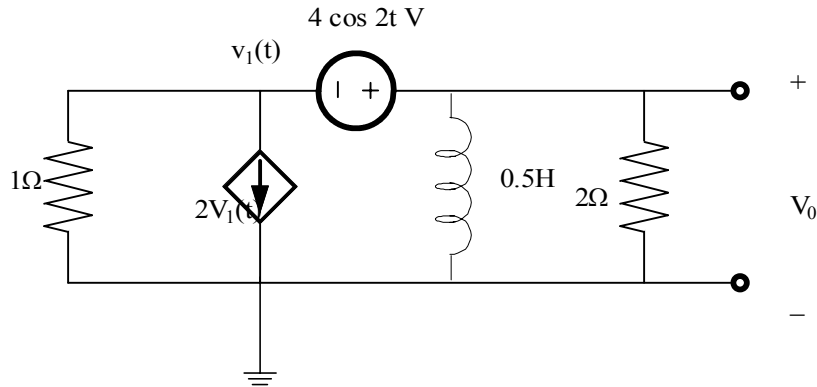

Suggested Solution

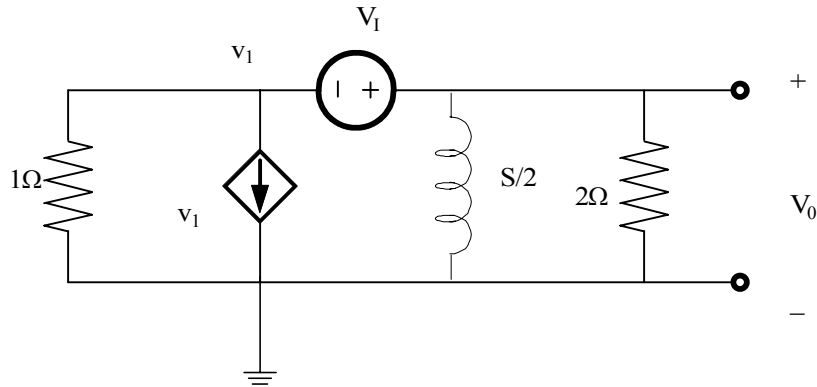

Nodal Analysis

$$V_1 + 2V_1 + V_0 \left(\frac{2}{s} \right) + \frac{V_0}{2} = 0$$

$$V_1 = V_0 - V_1$$

$$3V_0 - 3V_1 + \frac{2V_0}{s} + \frac{V_0}{2} = 0$$

so,

$$6V_1 = V_0 \left(6 + \frac{4}{s} + 1 \right)$$

$$\frac{V_0}{V_1} = \frac{6s}{7s + 4}$$

at Steady State $s = j2$ since

$$V_i(t) = 4 \cos(2t)$$

$$\left. \frac{V_0}{V_f} \right|_{j2} = \frac{j12}{4 + j14} = 0.82 \angle 15.95^\circ$$

since

$$|V_i| = 4$$

$$V_0 = 4(0.82) \angle 15.95^\circ = 3.3 \angle 15.95^\circ$$

$$V_0(t) = 3.3 \cos(2t + 15.95^\circ) \text{ V}$$

Problem 13.61

Find the steady state response $i_o(t)$ for the network shown the fig.

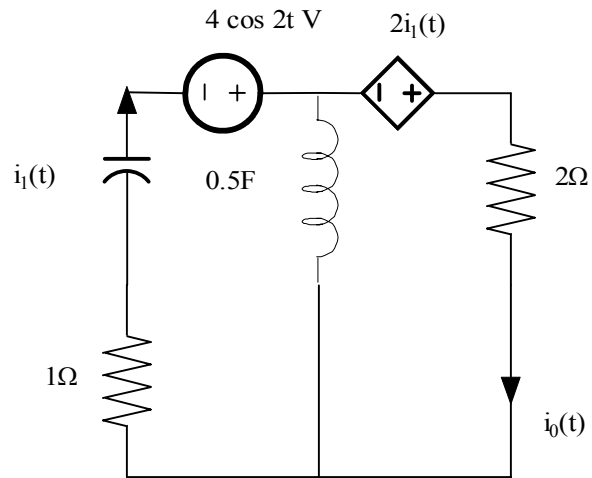

Suggested Solution

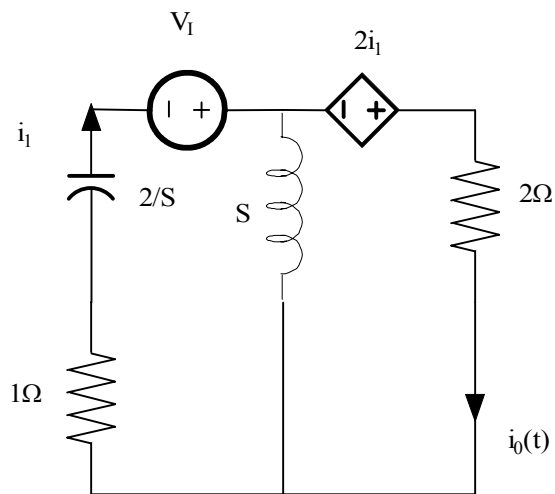

Loop Equations

$$I_0 \text{ Loop: } 2I_1 = (s+2)I_0 - sI_1$$

$$I_1 = I_0$$

$$I_1 \text{ Loop: } V_1 = s(I_1 - I_0) + I_1 + \frac{2I_1}{s}$$

$$V_1 = I_0 \left(1 + \frac{2}{s}\right)$$

$$\frac{I_0}{V_i} = \frac{s}{s+2}$$

since

$$V_i(t) = 4 \cos(2t)$$

at Steady State $j = j2$

$$\frac{I_0}{V_i} = \frac{j2}{s+j2} = \frac{1}{\sqrt{2}} \angle 45^\circ$$

since

$$|V_i| = 4$$

$$I_0 = \frac{4}{\sqrt{2}} \angle 45^\circ$$

$$I_0(t) = 2\sqrt{2} \cos(2t + 45^\circ) A$$

Problem 13.62

Find the steady state response $i_o(t)$ for the network shown the fig.

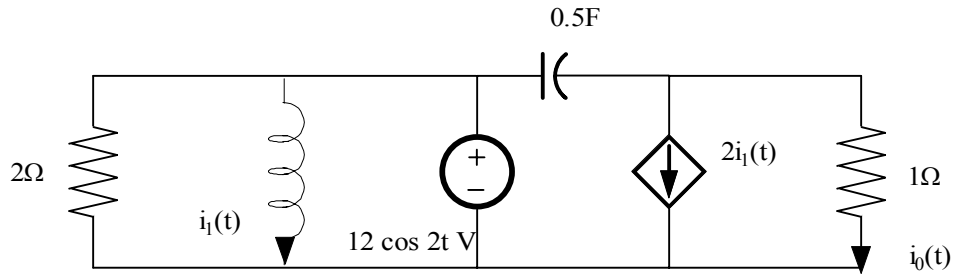

Suggested Solution

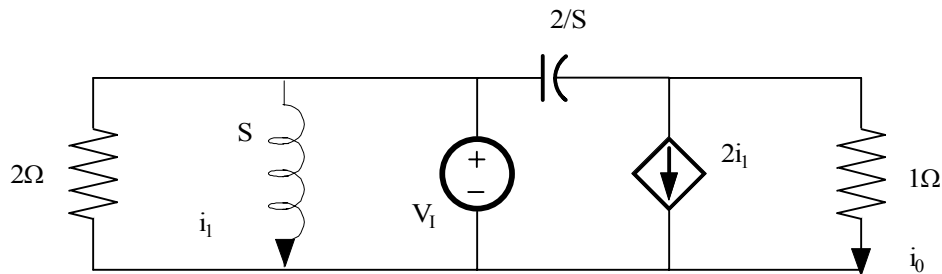

KCL

$$\frac{V_o}{1} + 2I_1 + (V_o - V_1) \frac{s}{2} = 0$$

$$I_o = V_o / 1, I_1 = V_1 / s$$

$$I_o + \frac{2V_1}{s} + I_o \left(\frac{s}{2}\right) - V_1 \left(\frac{s}{2}\right) = 0$$

or

$$I_o \left(1 + \frac{s}{2}\right) = V_1 \left(\frac{s}{2} - \frac{2}{s}\right) = V_1 \left(\frac{s^2 - 4}{2s}\right)$$

$$I_o \left(\frac{s+2}{2}\right) = V_1 \left(\frac{s^2 - 4}{2s}\right)$$

Finally

$$\frac{I_o}{V_1} = \frac{s-2}{s}$$

at steady state $s=j2$

$$V_i(t) = 12 \cos(2t)$$

$$\frac{I_0}{V_i|_2} = \frac{j2-2}{j2} = \sqrt{2} \angle 45^\circ$$

and

$$I_0 = |V_i| \sqrt{2} \angle 45^\circ = 12\sqrt{2} \angle 45^\circ$$

$$I_0 = 12\sqrt{2} \cos(2t + \angle 45^\circ) A$$

Problem 13.63

Find the steady state response $I_o(t)$ for the network shown the fig.

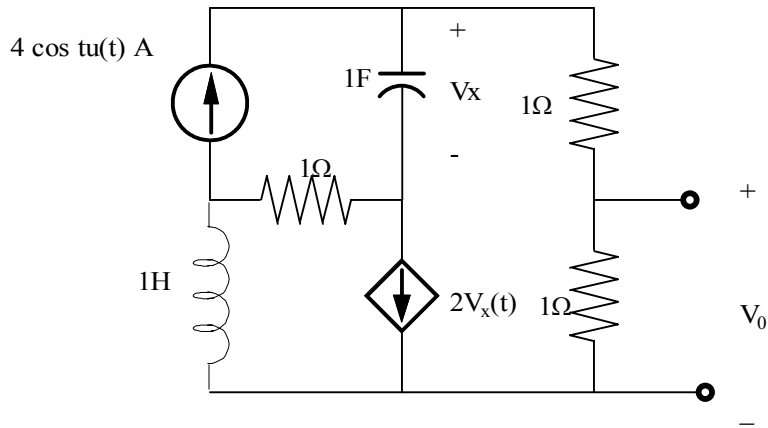

Suggested Solution

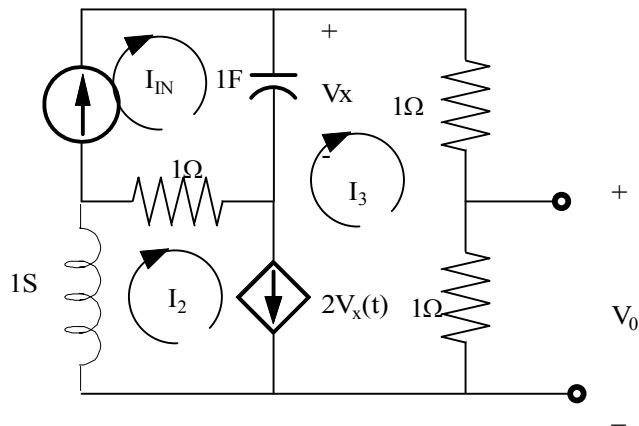

Loop Equations

$$I_3(2) + I_2(S) + (I_2 - I_{1N})(1) + \frac{I_3 - I_{1N}}{S} = 0$$

$$I_2(S+1) + I_3(2 + \frac{1}{S}) - I_{1N}(1 + \frac{1}{S}) = 0$$

$$V_o I_3$$

$$I_2 - I_3 = 2V_o = 2(I_{1N} - I_3)$$

$$I_{1N}(2 + \frac{2}{S} - 1 - \frac{1}{3}) + I_3[S + 1 - 2 + 2 - \frac{2}{S} + \frac{1}{S}] = 0$$

$$SI_{IN}(1 + \frac{1}{S}) = V_0[-S^2 - S + 1]$$

$$\frac{V_0}{I_{IN}} = \frac{-(S+1)}{S^2 + S - 1}$$

SINCE

$$I_{IN}(t) = 4\cos t (t > 0)$$

at steady state $s \rightarrow j1$

$$\frac{V_0}{I_{IN}} = \frac{-(1+j1)}{-2+j1} = 0.63 \angle 71.57^\circ$$

SINCE

$$|i_{IN}| = 4A$$

$$V_0 = 4(0.63) \angle 71.57^\circ$$

$$V_0(t) = 2.52 \cos(t + 71.57^\circ) V$$

Problem 13.64

Find the steady state response $I_o(t)$ for the network shown in the fig.

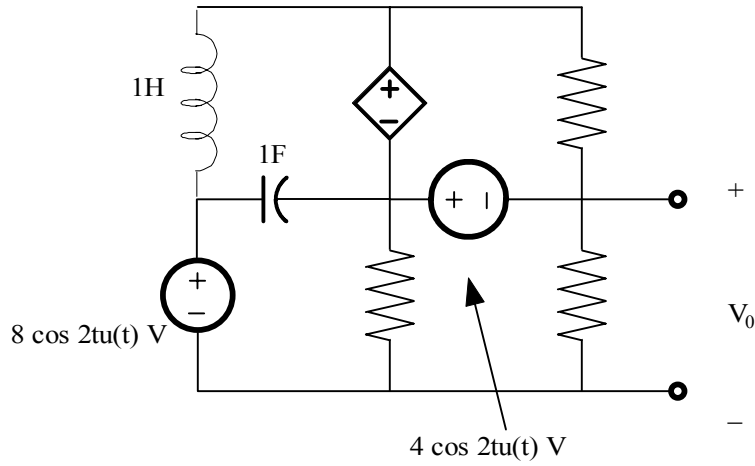

Suggested Solution

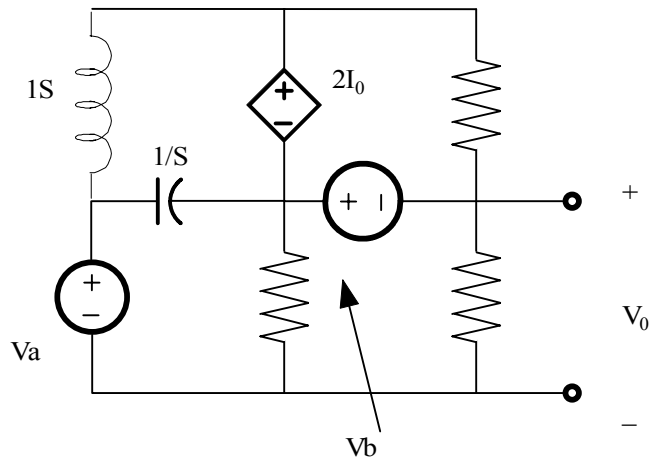

$$V_A(t) = 8 \cos 2t$$

$$V_B(t) = 4 \cos 2t$$

at steady state

$$V_A = 8 \angle 0^\circ V$$

$$V_B = 4 \angle 0^\circ V$$

KCL

$$\frac{V_1 - V_A}{s} + (V_2 - V_A)s = I_1$$

$$I_1 + V_2 + V_0 = 0$$

also

$$V_2 = V_0 + V_B$$

$$V_1 = 2I_0 + V_2 = 3V_2 = 3V_0 + 3V_B$$

combinig these equations yeilds

$$V_0 = V_A \left(\frac{s^2 + 1}{s^2 + 2s + 3} \right) - V_B \left(\frac{s^2 + s + 3}{s^2 + 2s + 3} \right)$$

at steady state

$$V_0 = \frac{8(-4+1) - 4(-4+3+j2)}{-1+3+j4} = 5.22 \angle 97.77^\circ$$

$$V_0(t) = 5.22 \cos(2t + 97.77^\circ)u(t)V$$

Problem 13FE-1

A single loop second order circuit is described by the following differential equation

What is the correct form of the total (natural plus forced) response?

Suggested Solution

The Characteristic Eqn is

$$s^2 + 2s + 2 = 0$$

or

$$(s + 1 \pm j1) = 0$$

with a constant forcing function - the answer is (0)

Problem 13FE-2

If all initial conditions are zero in the network in fig, find transfer function $V_o(s)/V_s(s)$ and determine the type of damping exhibited by the network.

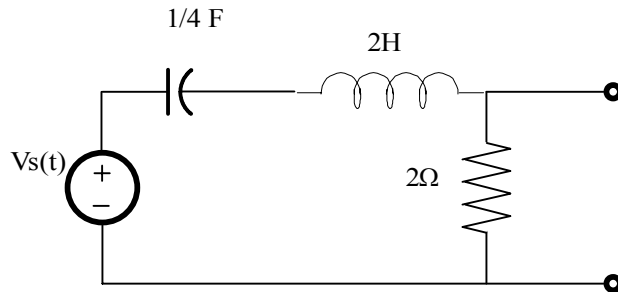

Suggested Solution

$$\frac{V_o}{V_s}(s) = \frac{2}{2 + 2s + \frac{4}{s}} = \frac{2s}{2s + s^2 + 4} = \frac{s}{s^2 + s + 2} = \frac{s}{s + \frac{1}{2}s \pm j\frac{\sqrt{7}}{4}}$$

The network is underdamped

Problem 13FE-3

The initial conditions in the circuit in fig are zeros. Find the transfer function $I_o(s)/I_s(s)$ and determine the type of damping exhibited by the circuit.

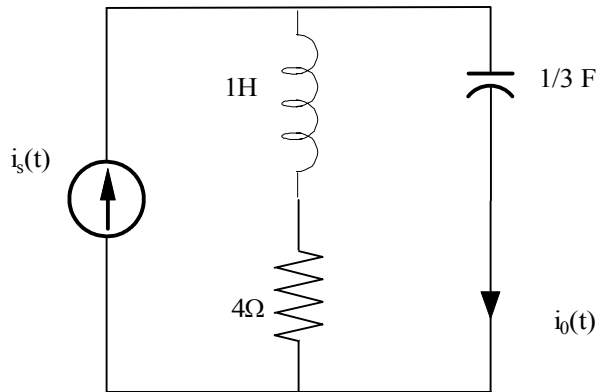

Suggested Solution

$$\frac{I_o(s)}{I_s(s)} = \frac{s+4}{s+4+\frac{3}{s}} = \frac{s(s+4)}{s^2+4s+3} = \frac{s(s+4)}{(s+1)(s+3)}$$

The network is overdamped

Problem 14.1

Find the exponential Fourier series for the signal shown.

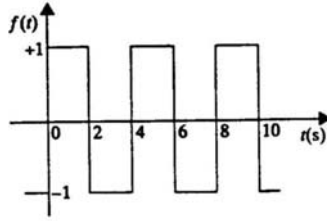

Suggested Solution

$$C_n = \frac{1}{T_0} \int_{-\frac{T_0}{2}}^0 -e^{-jn\omega_0 t} dt + \frac{1}{T_0} \int_0^{\frac{T_0}{2}} e^{-jn\omega_0 t} dt$$

$$C_n = \frac{1}{-T_0 j n \omega_0} \left[E^{-jn\omega_0 \frac{T_0}{2}} - 1 - 1 + e^{jn\omega_0 \frac{T_0}{2}} \right]$$

$$\omega_0 = \frac{2\pi}{T_0}$$

$$C_n = \frac{1}{2jn\pi} [2 - e^{jn\pi} - e^{-jn\pi}] = \frac{1}{2jn\pi} [2 - 2\cos(n\pi)]$$

$$C_0 = 0$$

$$C_n = \frac{1 - \cos(n\pi)}{jn\pi} = \begin{cases} 0 & n \text{ even} \\ \frac{2}{jn\pi} & n \text{ odd} \end{cases}$$

$$f(t) = \sum_{\substack{n=-\infty \\ n \neq 0 \\ n \text{ odd}}^{n=\infty}} \frac{2}{jn\pi} e^{jn\omega_0 t}$$

Problem 14.2

Find the exponential Fourier series for the periodic pulse train shown.

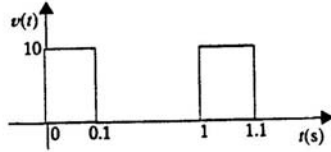

Suggested Solution

$$C_0 = \frac{10(0.1)}{1} = 1 \quad T_0 = 1 \quad \omega_0 = 2\pi$$

$$C_n = \frac{1}{T_0} \int_0^{T_0} 10e^{-jn\omega_0 t} dt$$

$$C_n = \frac{10}{-jn\omega_0 T_0} \left[e^{-jn\omega_0 t} \right]_0^{T_0} = \frac{5}{jn\pi} \left[1 - e^{-jn\frac{\pi}{5}} \right] = \frac{10}{-jn\omega_0 T_0} \left[\frac{e^{jn\frac{\pi}{10}} - e^{-jn\frac{\pi}{10}}}{j2} \right]$$

$$C_n = \frac{10}{n\pi} e^{-jn\frac{\pi}{10}} \sin\left(n\frac{\pi}{10}\right)$$

$$f(t) = \frac{10}{\pi} \sum_{n=-\infty}^{\infty} \frac{1}{n} e^{-jn\frac{\pi}{10}} \sin\left(n\frac{\pi}{10}\right) e^{jn\omega_0 t}$$

Problem 14.3

Find the exponential Fourier series for the periodic signal shown.

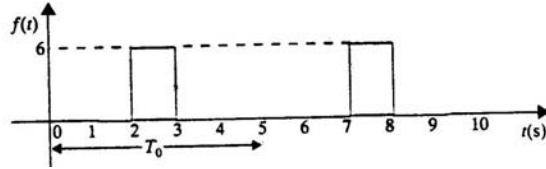

Suggested Solution

$$T_0 = 5 \quad \omega_0 T_0 = 2\pi$$

use time shift theorem with $t_0 = 2$ sec

$$C_n = \frac{1}{T_0} \int_0^{T_0} 6e^{-jn\omega_0 t} dt = \frac{6}{jn2\pi} \left[e^{jn\frac{\pi}{5}} - e^{-jn\frac{\pi}{5}} \right]$$

$$C_n = \frac{6e^{-jn\frac{\pi}{5}}}{n\pi} \sin\left(n\frac{\pi}{5}\right) \text{ and } f(t) = \sum_{n=-\infty}^{\infty} C_n e^{-jn\omega_0 t} e^{jn\omega_0 t}$$

$$f(t) = \sum_{n=-\infty}^{\infty} \frac{6}{n\pi} e^{-jn\pi} \sin\left(n\frac{\pi}{5}\right) e^{j0.4\pi t}$$

Problem 14.4

Compute the exponential Fourier series for the waveform that is the sum of the two waveforms shown by computing the exponential Fourier series of the two waveforms and adding them.

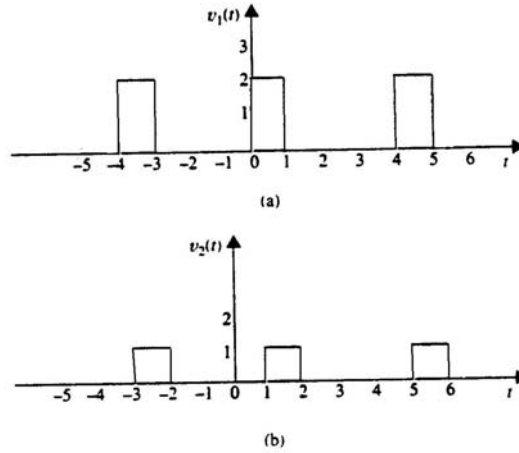

Suggested Solution

For $V_1(t)$, $T_0 = 4$ $\omega_0 T_0 = 2\pi$

$$C_{n_1} = \frac{2}{T_0} \int_0^{T_0} e^{-jn\omega_0 t} dt = \frac{2}{jn2\pi} \left[1 - e^{-jn\frac{\pi}{2}} \right]$$

For $V_2(t)$, note $V_2(t)$ is half as large and time shifted 1sec, or $\frac{T_0}{4}$

$$C_{n_2} = \frac{C_{n_1}}{2} e^{-jn\omega_0(1)} = \frac{C_{n_1}}{2} e^{-jn\frac{\pi}{2}}$$

$$C_n = C_{n_1} + C_{n_2}$$

$$C_n = \frac{1}{jn2\pi} \left\{ \left[2 - 2e^{-jn\frac{\pi}{2}} \right] + e^{-jn\frac{\pi}{2}} - e^{-jn\pi} \right\} = \frac{1}{jn\pi} \left[1 - \left(\frac{e^{jn\frac{\pi}{4}} + e^{-jn\frac{\pi}{4}}}{2} \right) e^{-jn\frac{3\pi}{4}} \right]$$

$$C_n = \frac{1}{jn\pi} \left(1 - e^{-jn\frac{3\pi}{4}} \cos\left(n\frac{\pi}{4}\right) \right)$$

$$V(t) = \sum_{n=-\infty}^{\infty} \left[\frac{i}{jn\pi} \left(1 - e^{-jn\frac{3\pi}{4}} \cos\left(n\frac{\pi}{4}\right) \right) \right] e^{jn\frac{\pi}{2}t} V$$

Problem 14.5

Find the exponential Fourier series for the signal shown.

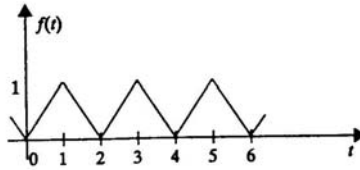

Suggested Solution

Comparing $f(t)$ to the waveforms in table 14.1 notice that $f(t)$ matches the even function symmetry triangular wave where

$$A=1 \quad T_0=2 \quad \& \quad \omega_0=\pi$$

$$C_0 = \frac{A}{2} = \frac{1}{2} \quad C_n = \frac{-2A}{n^2\pi^2} = \frac{-2}{n^2\pi^2} \begin{cases} n \neq 0 \\ n \text{ odd} \end{cases}$$

$$f(t) = \frac{1}{2} + \sum_{\substack{n=-\infty \\ n \neq 0 \\ n \text{ odd}}}^{\infty} \frac{-2}{n^2\pi^2} e^{jn\pi t}$$

Problem 14.6

Given the waveform shown, determine the type of symmetry that exists if the origin is selected at: (a) l_1 and (b) l_2 .

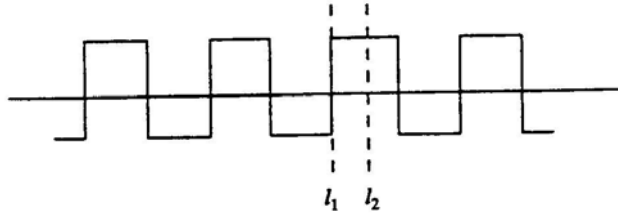

Suggested Solution

If origin is at l_1 , then $v(t) = -v(-t)$ odd symmetry

If origin is at l_2 , then $v(t) = v(-t)$ even symmetry

Problem 14.7

What type of symmetry is exhibited by the two waveforms shown?

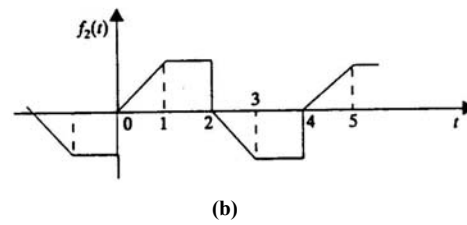
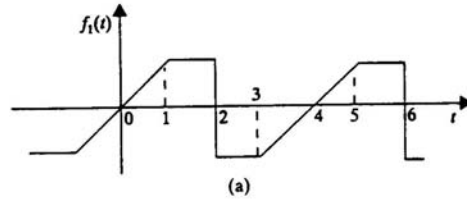

Suggested Solution

In part a) $f_1(t) = -f_1(t)$ odd symmetry

In part b) $f_2(t) = -f_2(t - T_0/2)$ half wave symmetry

Problem 14.8

Derive the trigonometric Fourier series for the waveform shown.

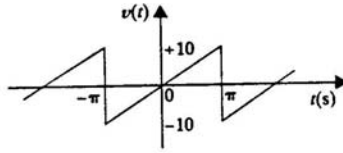

Suggested Solution

$$b_n = \frac{2}{T_0} \int_{-\frac{T_0}{2}}^{\frac{T_0}{2}} \frac{20}{T_0} t \sin(n\omega_0 t) dt = \frac{40}{T_0^2} \left[\frac{\sin(n\omega_0 t)}{(n\omega_0)^2} - \frac{t \cos(n\omega_0 t)}{n\omega_0} \right]_{-\frac{T_0}{2}}^{\frac{T_0}{2}}$$

$$b_n = \frac{40}{T_0^2} \left[\frac{\sin(n\pi)}{(n\omega_0)^2} - \frac{T_0 \cos(n\pi)}{2n\omega_0} + \frac{\sin(n\pi)}{(n\omega_0)^2} - \frac{T_0 \cos(n\pi)}{2n\omega_0} \right]$$

$$b_n = \frac{40}{T_0^2} \frac{T_0}{n\omega_0} \cos(n\pi) = (-1)^{n+1} \frac{20}{n\pi}$$

$$V(t) = \sum_{n=1}^{\infty} (-1)^{n+1} \frac{20}{n\pi} \sin(nt)$$

Problem 14.9

Find the trigonometric Fourier series coefficients for the waveform shown.

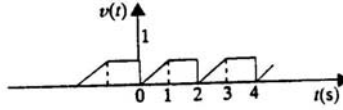

Suggested Solution

$$a_0 = \left[\frac{1}{2}(1)(1) + (1)(1) \right] = \frac{3}{4} \quad T_0 = 2 \text{ sec}$$

$$a_n = \frac{2}{T_0} \int_0^1 t \cos(n\omega_0 t) dt + \frac{2}{T_0} \int_1^2 \cos(n\omega_0 t) dt$$

$$a_n = \frac{2}{T_0} \left[\frac{t \sin(n\omega_0 t)}{n\omega_0} + \frac{\cos(n\omega_0 t)}{(n\omega_0)^2} \right]_0^1 + \frac{2}{n\omega_0 T_0} \sin(n\omega_0 t) \Big|_1^2$$

$$a_n = \frac{\sin(n\pi)}{n\pi} + \frac{\cos(n\pi)}{(n\pi)^2} - \frac{1}{(n\pi)^2} + \frac{\sin(2n\pi)}{n\pi} - \frac{\sin(n\pi)}{n\pi} = \frac{\cos(n\pi) - 1}{(n\pi)^2}$$

$$b_n = \frac{2}{T_0} \int_0^1 t \sin(n\omega_0 t) dt + \frac{2}{T_0} \int_1^2 \sin(n\omega_0 t) dt$$

$$b_n = \left[\frac{\sin(n\omega_0 t)}{(n\omega_0)^2} - \frac{t \cos(n\omega_0 t)}{n\omega_0} \right]_0^1 + \frac{\cos(n\omega_0 t)}{n\omega_0} \Big|_1^2$$

$$b_n = \frac{\sin(n\pi)}{(n\pi)^2} - \frac{\cos(n\pi)}{n\pi} + \frac{\cos(n\pi)}{n\pi} - \frac{\cos(2n\pi)}{n\pi} = -\frac{1}{n\pi}$$

$$a_0 = \frac{3}{4} \quad a_n = \frac{\cos(n\pi) - 1}{(n\pi)^2} \quad b_n = -\frac{1}{n\pi}$$

Problem 14.10

Find the trigonometric Fourier series coefficients for the waveform shown.

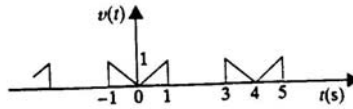

Suggested Solution

Even symmetry, $T_0 = 4$ $\omega_0 = \frac{\pi}{2}$

$$a_0 = \frac{\left(\frac{1}{2}\right)(1)(1)(2)}{4} = \frac{1}{4} \qquad b_n = 0$$

$$a_n = \int_0^1 t \cos\left(\frac{n\pi}{2}t\right) dt = \left[\frac{\cos(n\omega_0 t)}{(n\omega_0)^2} + \frac{t \sin(n\omega_0 t)}{n\omega_0} \right]_0^1$$

$$a_n = \frac{\cos\left(n\frac{\pi}{2}\right)}{(n\omega_0)^2} + \frac{\sin\left(n\frac{\pi}{2}\right)}{n\omega_0} - \frac{1}{(n\omega_0)^2} = \frac{4}{(n\pi)^2} \left(\cos\left(n\frac{\pi}{2}\right) - 1 \right) + \frac{2}{n\pi} \sin\left(n\frac{\pi}{2}\right)$$

$$a_0 = \frac{1}{4} \qquad a_n = \frac{4}{(n\pi)^2} \left(\cos\left(n\frac{\pi}{2}\right) - 1 \right) + \frac{2}{n\pi} \sin\left(n\frac{\pi}{2}\right)$$

Problem 14.11

Find the trigonometric Fourier series coefficients for the waveform shown.

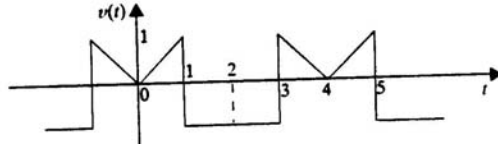

Suggested Solution

$V(t)$ can be expressed as the sum of the two wave forms shown below where

$V_1(t)$ is the wave form in Problem 14.10

Since $V_2(t)$ is of even form

$$a_{0_2} = -\frac{1}{2} \quad b_{n_2} = 0 \quad T_0 = 4$$

$$a_{n_2} = \frac{4}{T_0} \int_0^{T_0/2} V_2(t) \cos(n\omega_0 t) dt = \int_1^2 -\cos(n\omega_0 t) dt = \frac{-1}{n\omega_0} \left[\sin(n\pi) - \sin\left(n\frac{\pi}{2}\right) \right]$$

$$a_{n_2} = \frac{2}{n\pi} \sin\left(\frac{n\pi}{2}\right)$$

From problem 14.10: $a_{0_1} = \frac{1}{4}$ and $a_{n_1} = \frac{4}{(n\pi)^2} \left(\cos\left(n\frac{\pi}{2}\right) - 1 \right) + \frac{2}{n\pi} \sin\left(n\frac{\pi}{2}\right)$

$$a_0 = a_{0_1} + a_{0_2} = -\frac{1}{4} \quad b_n = 0$$

$$a_n = \frac{4}{(n\pi)^2} \left(\cos\left(n\frac{\pi}{2}\right) - 1 \right) + \frac{4}{n\pi} \sin\left(n\frac{\pi}{2}\right)$$

Problem 14.12

Find the trigonometric Fourier series for the waveform shown.

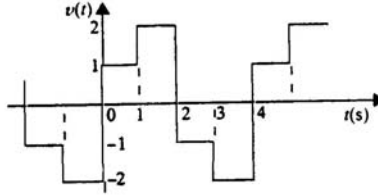

Suggested Solution

Half wave symmetry

$$a_0 = 0 \quad T_0 = 4 \text{ sec} \quad \omega_0 = \frac{\pi}{2}$$

$$a_n = b_n = 0 \quad \text{for } n \text{ even}$$

$$a_n = \frac{4}{T_0} \int_0^{T_0/2} f(t) \cos(n\omega_0 t) dt \quad \text{for } n \text{ odd}$$

$$a_n = \int_0^1 \cos(n\omega_0 t) dt + \int_1^2 2 \cos(n\omega_0 t) dt$$

$$a_n = \left. \frac{\sin n\omega_0 t}{n\omega_0} \right|_0^1 + \left. \frac{2 \sin n\omega_0 t}{n\omega_0} \right|_1^2$$

$$a_n = \frac{\sin\left(\frac{n\pi}{2}\right) + 2 \sin(n\pi) - 2 \sin\left(\frac{n\pi}{2}\right)}{\frac{n\pi}{2}}$$

$$a_n = \frac{-2}{n\pi} \sin\left(\frac{n\pi}{2}\right)$$

$$b_n = \frac{4}{T_0} \int_0^{T_0/2} f(t) \sin(n\omega_0 t) dt = \int_0^1 \sin(n\omega_0 t) dt + 2 \int_1^2 \sin(n\omega_0 t) dt$$

$$b_n = \left. \frac{\cos(n\omega_0 t)}{n\omega_0} \right|_0^1 + \left. \frac{\cos(n\omega_0 t)}{n\omega_0} \right|_1^2 = \frac{1 - \cos\left(\frac{n\pi}{2}\right) + 2 \cos\left(\frac{n\pi}{2}\right) - 2 \cos(n\pi)}{\frac{n\pi}{2}}$$

Since b_n holds only for n odd, $b_n = \frac{6}{n\pi}$

$$v(t) = \frac{2}{\pi} \sum_{\substack{n=1 \\ n \text{ odd}}}^{\infty} \frac{3}{n} \sin n\omega_0 t - \frac{1}{n} \sin\left(\frac{n\pi}{2}\right) \cos n\omega_0 t$$

Problem 14.13

Find the trigonometric Fourier series for the waveform shown.

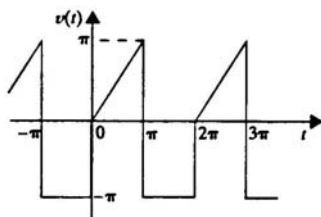

Suggested Solution

$$T = 2\pi \text{ sec} \quad \omega_0 = 1 \text{ r/s} \quad a_0 = \frac{\frac{\pi^2}{2} - \pi^2}{2\pi} = \frac{-\pi}{4}$$

This waveform is similar to that of prob. 14.15. If one multiplies $\omega(t)$ in 14.15 by negative π , one gets this waveform here. From 14.15.

$$a_0 = \frac{1}{4} \quad a_n = \frac{1}{n^2 \pi^2} (1 - \cos(n\pi)) \quad b_n = \frac{2 \cos(n\pi) - 1}{n\pi}$$

$$a_0 = \frac{-1}{4} \quad a_n = \frac{1}{\pi n^2} (\cos(n\pi) - 1) \quad b_n = \frac{1}{n} (1 - 2 \cos(n\pi))$$

Problem 14.14

Find the trigonometric Fourier series coefficients for the waveform shown.

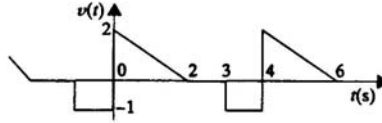

Suggested Solution

$$T_0 = 4 \text{ sec} \quad \omega_0 = \frac{\pi}{2} \quad a_0 = \frac{1}{T_0} \left[\frac{1}{2}(2)(2) - (1)(1) \right] = \frac{1}{4}$$

$$a_n = \frac{2}{T_0} \int_0^2 (2-t) \cos(n\omega_0 t) dt + \frac{2}{T_0} \int_3^4 -\cos(n\omega_0 t) dt$$

$$a_n = \frac{\sin(n\omega_0 t)}{n\omega_0} \Big|_0^2 + \left(\frac{t \sin(n\omega_0 t)}{2n\omega_0} + \frac{\cos(n\omega_0 t)}{2(n\omega_0)^2} \right) \Big|_2^0 + \frac{\sin(n\omega_0 t)}{2n\omega_0} \Big|_4^3$$

so,

$$a_n = \frac{\sin(n\pi)}{n\omega_0} + \frac{1}{2(n\omega_0)^2} - \frac{\sin(n\pi)}{n\omega_0} - \frac{\cos(n\pi)}{2(n\omega_0)^2} + \frac{\sin\left(\frac{n3\pi}{2}\right) - \sin(n2\pi)}{2n\omega_0}$$

$$a_n = \frac{2}{n^2 \pi^2} (1 - \cos(n\pi)) - \frac{\sin\left(\frac{n\pi}{2}\right)}{n\pi}$$

$$b_n = \frac{2}{T_0} \int_0^2 (2-t) \sin(n\omega_0 t) dt - \frac{2}{T_0} \int_{-1}^0 \sin(n\omega_0 t) dt$$

$$b_n = \frac{\cos(n\omega_0 t)}{n\omega_0} \Big|_2^0 + \left(\frac{t \cos(n\omega_0 t)}{2n\omega_0} - \frac{\sin(n\omega_0 t)}{2(n\omega_0)^2} \right) \Big|_0^2 + \frac{\cos(n\omega_0 t)}{2n\omega_0} \Big|_{-1}^0$$

$$b_n = \frac{1 - \cos(n\pi)}{n\omega_0} + \frac{\cos(n\pi)}{n\omega_0} - \frac{\sin(n\pi)}{2(n\omega_0)^2} + \frac{1 - \cos(-n\omega_0)}{2n\omega_0}$$

$$b_n = \frac{1}{2n\omega_0} [3 - \cos(n\omega_0)] = \frac{1}{n\pi} \left[3 - \cos\left(\frac{n\pi}{2}\right) \right]$$

$$a_0 = \frac{1}{4} \quad a_n = \frac{2}{n^2 \pi^2} (1 - \cos(n\pi)) - \frac{\sin\left(\frac{n\pi}{2}\right)}{n\pi} \quad b_n = \frac{1}{n\pi} \left[3 - \cos\left(\frac{n\pi}{2}\right) \right]$$

Problem 14.15

Find the trigonometric Fourier series coefficients for the waveform shown.

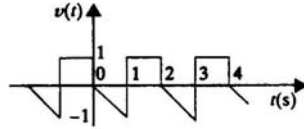

Suggested Solution

$$T_0 = 2 \text{ sec} \quad \omega_0 = \pi \text{ r/s} \quad a_0 = \frac{2}{T_0} \left[(-1)(1) \left(\frac{1}{2} \right) + (1)(1) \right] = \frac{1}{4}$$

$$a_n = \frac{2}{T_0} \int_0^1 -t \cos(n\omega_0 t) dt + \frac{2}{T_0} \int_1^2 \cos(n\omega_0 t) dt$$

$$a_n = \left(\frac{\cos(n\pi t)}{(n\pi)^2} + \frac{t \sin(n\pi t)}{n\pi} \right) \Big|_0^1 + \frac{\sin(n\pi t)}{n\pi} \Big|_1^2$$

$$a_n = \frac{1}{(n\pi)^2} - \frac{\cos(n\pi)}{(n\pi)^2} - \frac{\sin(n\pi)}{n\pi} + \frac{\sin(2\pi) - \sin(n\pi)}{n\pi}$$

$$a_n = \frac{1}{n^2 \pi^2} (1 - \cos(n\pi))$$

$$b_n = \frac{2}{T_0} \int_0^1 -t \sin(n\omega_0 t) dt + \frac{2}{T_0} \int_1^2 \sin(n\omega_0 t) dt$$

$$b_n = \left(\frac{t \cos(n\omega_0 t)}{n\omega_0} - \frac{\sin(n\omega_0 t)}{(n\omega_0)^2} \right) \Big|_0^1 + \frac{\cos(n\omega_0 t)}{n\omega_0} \Big|_2^1$$

$$b_n = \frac{\cos(n\pi)}{n\pi} - \frac{\sin(n\pi)}{(n\pi)^2} - \frac{\cos(n\pi)}{n\pi} - \frac{\cos(2\pi n)}{n\pi} = \frac{2}{n\pi} \cos(n\pi) - \frac{1}{n\pi}$$

$$a_0 = \frac{1}{4} \quad a_n = \frac{1}{n^2 \pi^2} (1 - \cos(n\pi)) \quad b_n = \frac{1}{n\pi} [2 \cos(n\pi) - 1]$$

Problem 14.16

Find the trigonometric Fourier series coefficients for the waveform shown.

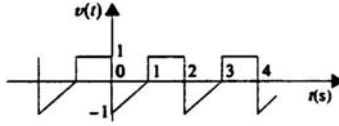

Suggested Solution

$$T_0 = 2 \text{ sec} \quad \omega_0 = \pi \text{ r/s} \quad a_0 = \frac{1}{T_0} \left[\left(\frac{1}{2} \right) (1)(-1) + (1)(1) \right] = \frac{1}{4}$$

$$a_n = \frac{2}{T_0} \left[\int_0^1 (t-1) \cos(n\omega_0 t) dt + \int_1^2 \cos(n\omega_0 t) dt \right]$$

$$a_n = \left(\frac{\cos(n\pi t)}{(n\pi)^2} + \frac{t \sin(n\pi t)}{n\pi} \right) \Big|_0^1 - \frac{\sin(n\pi t)}{n\pi} \Big|_0^1 + \frac{\sin(n\pi t)}{n\pi} \Big|_1^2$$

so,

$$a_n = \frac{\cos(n\pi)}{(n\pi)^2} + \frac{\sin(n\pi)}{n\pi} - \frac{1}{(n\pi)^2} - \frac{\sin(n\pi)}{n\pi} + \frac{\sin(2\pi n)}{n\pi} - \frac{\sin(n\pi)}{n\pi}$$

$$a_n = \frac{1}{n^2 \pi^2} [\cos(n\pi) - 1]$$

$$b_n = \frac{2}{T_0} \int_0^1 (t-1) \sin(n\omega_0 t) dt + \frac{2}{T_0} \int_1^2 \sin(n\omega_0 t) dt$$

$$b_n = \left(\frac{\sin(n\omega_0 t)}{(n\omega_0)^2} - \frac{t \cos(n\omega_0 t)}{n\omega_0} \right) \Big|_0^1 + \frac{\cos(n\omega_0 t)}{n\omega_0} \Big|_1^2 + \frac{\cos(n\omega_0 t)}{n\omega_0} \Big|_0^1$$

$$b_n = \frac{\sin(n\pi)}{(n\pi)^2} - \frac{\cos(n\pi)}{n\pi} + \frac{\cos(n\pi)}{n\pi} - \frac{\cos(2\pi n)}{n\pi} + \frac{\cos(n\pi)}{n\pi} - \frac{1}{n\pi}$$

$$b_n = \frac{1}{n\pi} [\cos(n\pi) - 2] \quad a_n = \frac{1}{n^2 \pi^2} [\cos(n\pi) - 1] \quad a_0 = \frac{1}{4}$$

Problem 14.17

Derive the trigonometric Fourier series for the function shown.

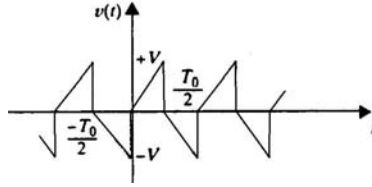

Suggested Solution

Half wave symmetry $a_0 = 0$ $a_n = b_n = 0$ for n even

$$a_n = \frac{4}{T_0} \int_0^{T_0/2} \frac{2vt}{T_0} \cos(n\omega_0 t) dt = \frac{8v}{T_0^2} \int_0^{T_0/2} t \cos(n\omega_0 t) dt$$

$$a_n = \frac{8v}{T_0^2} \left[\frac{t \sin(n\omega_0 t)}{n\omega_0} + \frac{\cos(n\omega_0 t)}{(n\omega_0)^2} \right] \Bigg|_0^{T_0/2}$$

$$a_n = \frac{8v}{T_0^2} \left[\frac{T_0}{2} \left(\frac{\sin n\pi}{n\omega_0} + \frac{\cos(n\pi) - 1}{(n\omega_0)^2} \right) \right]$$

For n odd, $a_n = \frac{8v}{T_0^2} \left[\frac{-2T_0^2}{4n^2\pi^2} \right] = \frac{-4v}{n^2\pi^2}$

$$b_n = \frac{4}{T_0} \int_0^{T_0/2} \frac{2v}{T_0} t \sin(n\omega_0 t) dt = \frac{8v}{T_0^2} \left[\frac{\sin(n\omega_0 t)}{(n\omega_0)^2} - \frac{t \cos(n\omega_0 t)}{n\omega_0} \right] \Bigg|_0^{T_0/2}$$

$$b_n = \frac{8v}{T_0^2} \left[\frac{\sin(n\pi)}{(n\omega_0)^2} - \frac{T_0}{2} \left(\frac{\cos(n\pi)}{n\omega_0} \right) \right] = 0 \quad \text{for } n \text{ odd, } b_n = \frac{2v}{n\pi}$$

$$v(t) = \sum_{\substack{n=1 \\ n \text{ odd}}}^{\infty} \frac{2v}{n\pi} \sin(n\omega_0 t) - \frac{4v}{n^2\pi^2} \cos(n\omega_0 t)$$

Problem 14.18

Derive the trigonometric Fourier series for the function $v(t) = A|\sin t|$ as shown.

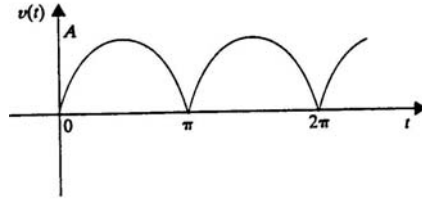

Suggested Solution

$$T_0 = \pi \quad \omega_0 = 2 \quad v(t) = A \sin |t|$$

even function, $b_n = 0$

$$a_0 = \frac{1}{T_0} \int_0^{T_0} A \sin(t) dt = \frac{A}{T_0} \cos t \Big|_0^{T_0} = \frac{2A}{T_0}$$

$$a_n = \frac{4}{T_0} \int_0^{T_0/2} A \sin(t) \cos(n\omega_0 t) dt$$

Use trig. identity,

$$\sin \phi \cos \theta = \frac{\sin(\phi + \theta)}{2} + \frac{\sin(\phi - \theta)}{2}$$

Now,

$$a_n = \frac{4A}{2T_0} \int_0^{T_0/2} [\sin(2n+1)t + \sin(1-2n)t] dt$$

$$a_n = \frac{2A}{\pi} \left[\frac{\cos(1+2n)t}{1+2n} + \frac{\cos(1-2n)t}{1-2n} \right] \Big|_0^{T_0/2} = \frac{1 - \cos\left((1+2n)\frac{\pi}{2}\right)}{1+2n} + \frac{1 - \cos\left((1-2n)\frac{\pi}{2}\right)}{1-2n}$$

Since $\cos\left[(1+2n)\frac{\pi}{2}\right] = \cos\left[(1-2n)\frac{\pi}{2}\right] = 0$ for all n ,

$$a_n = \frac{2A}{\pi} \left[\frac{1-2n+1+2n}{(1-2n)(1+2n)} \right] = \frac{4A}{\pi(1-4n^2)}$$

$$f(t) = \frac{2A}{\pi} \left[1 + 2 \sum_{n=1}^{\infty} \frac{\cos(2nt)}{1-4n^2} \right]$$

$$a_0 = \frac{2A}{\pi} \quad a_n = \frac{4A}{\pi(1-4n^2)} \quad b_n = 0$$

Problem 14.19

Derive the trigonometric Fourier series for the waveform shown.

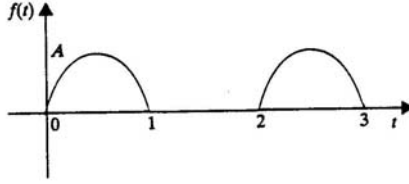

Suggested Solution

$$T_0 = 2 \quad \omega_0 = \pi \quad a_0 = \frac{1}{T_0} \int_0^1 A \sin(\pi t) dt = \frac{A}{2\pi} \cos(\pi t) \Big|_0^1 = \frac{A}{\pi}$$

$$a_n = \frac{2}{T_0} \int_0^1 A \sin(\pi t) \cos(n\pi t) dt$$

$$\text{Trig. identity } \sin \phi \cos \theta = \frac{\sin(\phi - \theta) + \sin(\phi + \theta)}{2}$$

$$a_n = \frac{A}{2} \int_0^1 (\sin(1-n)\pi t + \sin(1+n)\pi t) dt$$

$$a_n = \frac{A}{2} \left[\frac{\cos(1-n)\pi t}{(1-n)\pi} + \frac{\cos(1+n)\pi t}{(1+n)\pi} \right] \Big|_0^1$$

so,

$$a_n = \frac{A}{2} \left[\frac{1 - \cos(1-n)\pi}{(1-n)\pi} + \frac{1 - \cos(1+n)\pi}{(1+n)\pi} \right] \quad \text{if } n \text{ is odd } a_n = 0$$

$$\text{If } n \text{ is even, } a_n = \frac{A}{2\pi} \left[\frac{2}{1-n} + \frac{2}{1+n} \right] = \frac{2A}{\pi(1-n^2)}$$

$$b_n = \frac{2}{T_0} \int_0^1 A \sin(\pi t) \sin(n\pi t) dt = \begin{cases} 0, & \text{for } n \neq 1 \\ A \int_0^1 \sin^2(\pi t) dt & \text{for } n = 1 \end{cases}$$

$$\text{Since } \sin^2 \theta = \frac{1}{2}(1 - \cos 2\theta),$$

$$b_n = \frac{A}{2} \int_0^1 (1 - \cos(2\pi t)) dt = \frac{A}{2} \left[t - \frac{\sin(2\pi t)}{2\pi} \right] \Big|_0^1 = \frac{A}{2} [1]$$

so,

$$f(t) = \frac{A}{\pi} + \frac{A}{2} \sin(\pi t) + \sum_{\substack{n=2 \\ n \text{ even}}}^{\infty} \frac{2A}{\pi(1-n^2)} \cos(n\omega_0 t)$$

Problem 14.20

Use PSpice to determine the Fourier series of the waveform shown in the form.

$$V_S(t) = a_0 + \sum_{n=1}^{\infty} b_n \sin(n\omega_0 t + \theta_n)$$

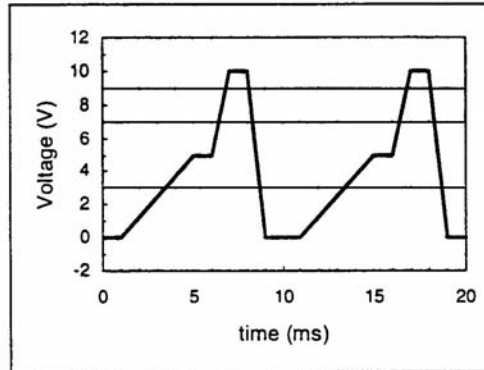

Suggested Solution

Transient specifics were Final Time=10ms, Step Ceiling=10us,
Center Frequency=100 Hz and Number of Harmonics=10

FOURIER COMPONENTS OF TRANSIENT RESPONSE V(Vs)
DC COMPONENT= 3.750000E+00

HARMONIC NO	FREQUENCY (HZ)	FOURIER PHASE (DEG)	NORMALIZED COMPONENT	PHASE COMPONENT	NORMALIZED (DEG)
1	1.000E+02	0.000E+00	3.954E+00	1.000E+00	-1.424E+02
2	2.000E+02	1.971E+02	2.016E+00	5.099E-01	-8.774E+01
3	3.000E+02	4.185E+02	1.247E+00	3.154E-01	-8.735E+00
4	4.000E+02	6.395E+02	6.417E-01	1.623E-01	6.991E+01
5	5.000E+02	8.020E+02	2.027E-01	5.126E-02	9.000E+01
6	6.000E+02	9.645E+02	2.852E-01	7.213E-02	1.101E+02
7	7.000E+02	8.256E+02	2.291E-01	5.793E-02	-1.713E+02
8	8.000E+02	1.047E+03	1.260E-01	3.188E-02	-9.226E+01
9	9.000E+02	1.244E+03	4.883E-02	1.235E-02	-3.759E+01
10	1.000E+03	1.303E+03	1.993E-08	5.040E-09	-1.206E+02

TOTAL HARMONIC DISTORTION = 6.310255E+01 PERCENT

Problem 14.21

Use PSpice to determine the Fourier series of the waveform shown in the form

$$v_s(t) = a_0 + \sum_{n=1}^{\infty} b_n \sin(n\omega_0 t + \theta_n)$$

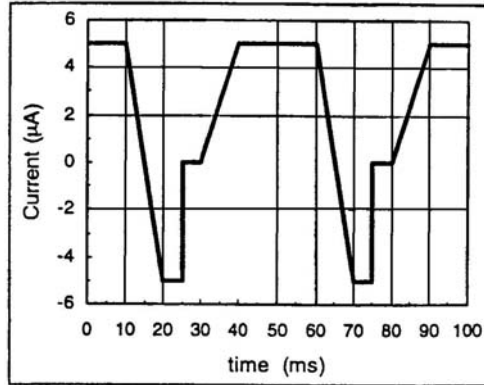

Suggested Solution

Transient specifics were Final Time=10ms, Step Ceiling=10us,
Center Frequency=100 Hz and Number of Harmonics=10

FOURIER COMPONENTS OF TRANSIENT RESPONSE V(Vs)
DC COMPONENT= 1.997500E+00

HARMONIC NO	FREQUENCY (HZ)	FOURIER COMPONENT	NORMALIZED COMPONENT	PHASE (DEG)	NORMALIZED PHASE(DEG)
1	2.000E+01	4.401E+00	1.000E+00	1.049E+02	0.000E+00
2	4.000E+01	1.669E+00	3.792E-01	-3.975E+01	-2.495E+02
3	6.000E+01	8.810E-01	2.002E-01	-1.480E+02	-4.627E+02
4	8.000E+01	4.518E-01	1.027E-01	3.521E+01	-3.844E+02
5	1.000E+02	3.183E-01	7.233E-02	1.791E+02	-3.454E+02
6	1.200E+02	3.001E-01	6.819E-02	2.212E+01	-6.073E+02
7	1.400E+02	2.046E-01	4.648E-02	-1.565E+02	-8.907E+02
8	1.600E+02	1.829E-01	4.157E-02	-2.297E+01	-8.621E+02
9	1.800E+02	1.913E-01	4.347E-02	1.625E+02	-7.816E+02
10	2.000E+02	1.592E-01	3.617E-02	-1.800E+00	-1.051E+03

TOTAL HARMONIC DISTORTION= 4.597325E+01 PERCENT

Problem 14.22

The discrete line spectrum for a periodic function $f(t)$ is shown. Determine the expression for $f(t)$.

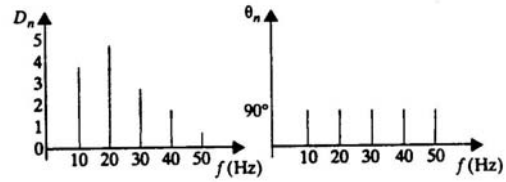

Suggested Solution

$$f_0 = 10\text{HZ} \qquad \omega_0 = 20\pi \text{ r/s} \qquad D_n = 2 |C_n|$$

$$D_n = |\underline{\theta}_n = a_n - jb_n$$

$$\text{all } \theta_n = 90^\circ \qquad a_n = 0 \qquad \text{and } b_n = -D_n$$

$$f(t) = -4\sin(20\pi t) - 5\sin(40\pi t) - 3\sin(60\pi t) - 2\sin(80\pi t) - \sin(100\pi t)$$

Problem 14.23

The amplitude and phase spectra for a periodic function $v(t)$ that has only a small number of terms is shown. Determine the expression for $v(t)$ if $T_0 = 0.1$ s.

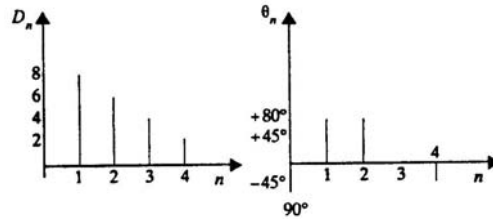

Suggested Solution

$$T_0 = 0.1 \text{ sec}$$

$$\omega_0 = 20\pi \text{ r/s}$$

n	a_n	θ_n
1	8	80°
2	6	80°
3	4	0°
4	2	-45°

$$v(t) = 8\cos(20\pi t + 80^\circ) + 6\cos(40\pi t + 80^\circ) + 4\cos(60\pi t) + 2\cos(80\pi t - 45^\circ)$$

Problem 14.24

Plot the first four terms of the amplitude and phase spectra for the signal

$$f(t) = \sum_{\substack{n=1 \\ n \text{ odd}}}^{\infty} \frac{-2}{n\pi} \sin\left(\frac{n\pi}{2}\right) \cos(n\omega_0 t) + \frac{6}{n\pi} \sin(n\omega_0 t)$$

Suggested Solution

$$f(t) = \sum_{\substack{n=1 \\ n \text{ odd}}}^{\infty} \frac{-2}{n\pi} \sin\left(\frac{n\pi}{2}\right) \cos\left(n\omega_0 t + \frac{6}{n\pi}\right) \sin(n\omega_0 t)$$

$$a_n = \frac{-2}{n\pi} \sin\left(\frac{n\pi}{2}\right) \left. \vphantom{\frac{-2}{n\pi} \sin\left(\frac{n\pi}{2}\right)} \right\} n \text{ odd}$$

$$b_n = \frac{6}{n\pi}$$

$$D_n = \sqrt{a_n^2 + b_n^2} \quad \theta_n = \tan^{-1}\left(\frac{-b_n}{a_n}\right)$$

n	D_n	θ_n ($^\circ$)
1	2.01	-108
2	0	0
3	0.67	-72
4	0	0
5	0.40	-108
6	0	0
7	0.29	-72

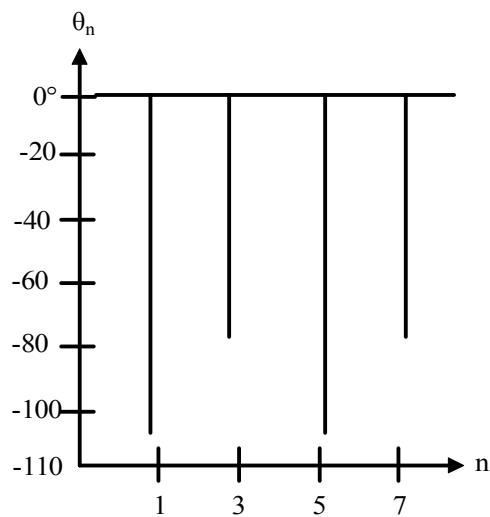
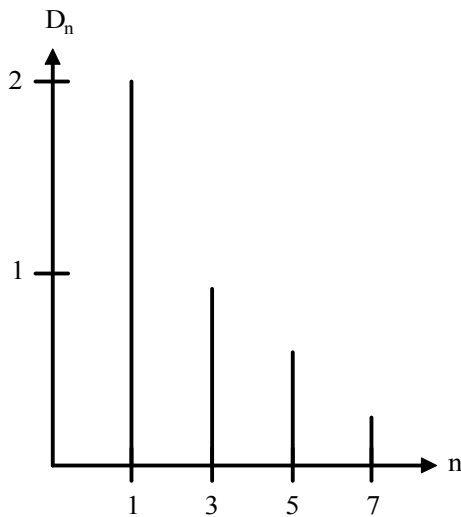

Problem 14.25

Determine the steady-state response of the current $i_o(t)$ in the circuit shown if the input voltage is described by the waveform shown in Problem 14.8.

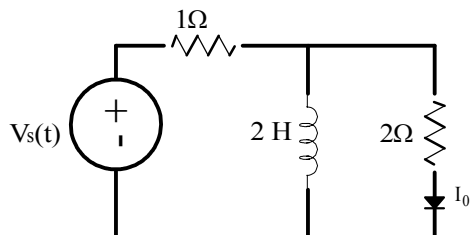

Suggested Solution

$$Z = jzn \parallel 1 = \frac{jzn}{1 + jzn}$$

From 14.8, $T_0 = 2\pi$, $\omega_0 = 1 \text{ r/s}$

$$v_s(t) = \sum_{n=1}^{\infty} (-1)^{n+1} \frac{20}{n\pi} \cos(nt - 90^\circ) V$$

$$\frac{I_0}{V_s} = \frac{Z}{Z + 2} = \frac{jzn}{jzn + z + j4n} = \frac{jn}{1 + j3n}$$

let $G(n) = \frac{jn}{1 + j3n}$ and $\theta_n = \angle G(n)$

$$I_{0(n)} = V_s(n)G(n)$$

$$i_o(t) = \frac{(-1)^{n+1} 20}{n\pi} |G(n)| \cos(nt - 90^\circ + \theta_n)$$

Problem 14.26

If the input voltage in Problem 14.25 is

$$v_s(t) = 1 - \frac{2}{\pi} \sum_{n=1}^{\infty} \frac{1}{n} \sin(0.2\pi nt) V$$

find the expression for the steady-state current $i_o(t)$.

Suggested Solution

prob. 14.25 circuit w/ $v_s(t) = 1 - \frac{2}{\pi} \sum_{n=1}^{\infty} \frac{1}{n} \sin\left(\frac{\pi nt}{5}\right) V$

$$\text{Now, } \omega_0 = \frac{\pi}{s}, \quad \frac{I_0}{V_s} = \frac{j2n\omega_0}{2 + j6n\omega_0} = \frac{jn\frac{\pi}{s}}{1 + j3n\frac{\pi}{s}} = \frac{jn\pi}{5 + j3n\pi}$$

$$\text{Now, } G(n) = \frac{jn\pi}{5 + j3n\pi} \text{ and } \theta_n = \angle G(n)$$

From the circuit, i_0 dc component is zero, 50,

$$i_0(t) = \sum_{n=1}^{\infty} \frac{-2}{\pi n} |G(n)| \cos\left(\frac{\pi nt}{s} - 90^\circ + \theta_n\right) A$$

Problem 14.27

Determine the first three terms of the steady-state voltage $v_o(t)$ if the input voltage is a periodic signal of the form

$$v_s(t) = \frac{1}{2} + \sum_{n=1}^{\infty} \frac{1}{n\pi} (\cos(n\pi - 1)) \sin(nt) V$$

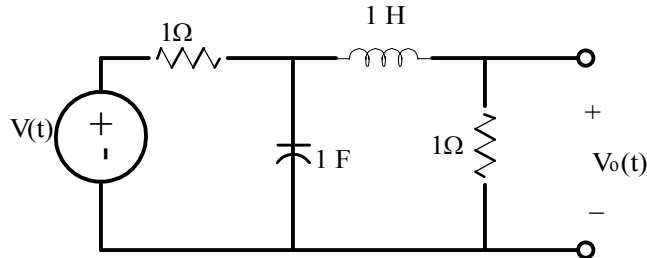

Suggested Solution

$$V_{TH} = \frac{V}{1 + jn} \quad Z_{TH} = \frac{1}{1 + jn}$$

$$\frac{V_o}{V_{TH}} = \frac{1}{1 + jn + Z_{TH}} = \frac{1 + jn}{(1 + jn)^2 + 1}$$

$$V_o = \frac{V(n)}{2 - n^2 + j2n} \quad \text{let} \quad H(n) = \frac{1}{2 - n^2 + j2n} \quad \text{and} \quad \theta_n = \angle H(n)$$

$$V_o = \frac{1}{4} \quad V_o(1) = \frac{\frac{+2}{\pi} \angle 90^\circ}{1 + j2} = 0.28 \angle 26.6^\circ$$

$$V_o(2) = 0 \quad V_o(3) = \frac{\frac{2}{3\pi} \angle -49^\circ}{-7 + j6} = 0.023 \angle -49^\circ$$

$$V_o = \frac{1}{4} \quad V_o(1) = 0.28 \angle 26.6 \quad V_o(2) = 0 \quad V_o(3) = 0.023 \angle -49.4^\circ$$

Problem 14.28

The current $i_s(t)$ shown is applied to the circuit shown. Determine the expression for the steady-state current $i_o(t)$ using the first four harmonics.

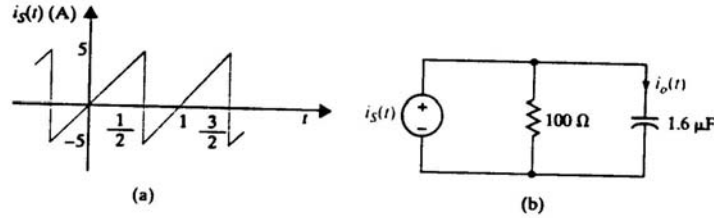

Suggested Solution

$$T_0 = 1 \quad \omega_0 = 2\pi$$

From Table 15.1,
$$i_s(t) = \sum_{n=1}^{\infty} (-1)^{n+1} \frac{10}{n\pi} \sin(n\omega_0 t)$$

$$I_0 = I_s \left[\frac{100}{100 - j \frac{100k}{n}} \right] = \left[\frac{n}{n - j100} \right] \quad \text{Let } H(n) = \frac{n}{n - j100}$$

n	$ H(n) $	$\angle H(n)$	b_n (for $i_s(t)$)
1	10^{-3}	89.9	$\frac{10}{\pi}$
2	2×10^{-3}	89.9	$\frac{-5}{\pi}$
3	3×10^{-3}	89.8	$\frac{10}{3\pi}$
4	4×10^{-3}	89.8	$\frac{-5}{2\pi}$

$$i_o = 3.18 \sin(2\pi t + 89.9^\circ) - 3.18 \sin(4\pi t + 89.9^\circ) + 3.18 \sin(6\pi t + 89.8^\circ) - 3.18 \sin(8\pi t + 89.8^\circ) \text{ mA}$$

Problem 14.29

Find the average power absorbed by the network shown if

$$V(t) = 50 + 25 \cos(377t + 45^\circ) + 24 \cos(754t - 60^\circ) \text{ V.}$$

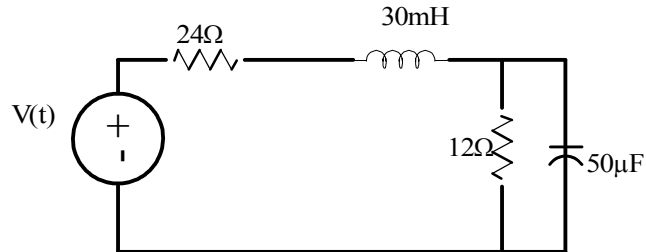

Suggested Solution

$$v(t) = 60 + 36 \cos(\omega_0 t + 45^\circ) + 24(2\omega_0 t - 60^\circ) \text{ V}$$

$$\omega_0 = 377 \text{ r/s}$$

$$\frac{I}{V} = \frac{1}{24 + jn11.31 + 12 \parallel \frac{53.1}{jn}} = \frac{1}{24 - jn11.31 + \frac{636.6}{53.1 + jn12}} = \frac{53.1 + jn12}{1911 - n^2 135.7 + jn600}$$

$$V_{dc} = 60 \text{ V} \quad I_{dc} 60 \left(\frac{53.1}{1911} \right) = 1.67 \text{ A}$$

$$V(1) = 36 \text{ V} \quad \theta_{v_1} = 45^\circ \quad I(1) = 1.05 \angle 39.1^\circ$$

$$V(2) = 24 \text{ V} \quad \theta_{v_2} = -60^\circ \quad I(2) = 0.77 \angle -76.9^\circ$$

$$P = 60(1.67) + \frac{36(1.05)}{2} \cos(5.9) + \frac{24(0.77)}{2} \cos(16.9^\circ)$$

$$P = 127.8 \text{ W}$$

Problem 14.30

Find the average power absorbed by the 12- Ω resistor in the network of Problem 14.29 if

$$V(t) = 50 = 25 \cos(377t - 45^\circ) + 12.5 \cos(754t + 45^\circ) \text{ V.}$$

Suggested Solution

$$V(t) = 50 + 25 \cos(\omega_0 - 45^\circ) + 12.5 \cos(2\omega_0 t + 45^\circ)$$

$$\omega_0 = 377 \frac{\text{rad}}{\text{s}}$$

$$Z = 12 \parallel \frac{53.1}{jn} = \frac{637.2}{53.1 + j12n}$$

$$\frac{V_0}{V} = \frac{Z}{Z + 24 + jn11.31} = \frac{637.2}{637.2 + 1274.4 - n^2 137.7 + j888.6n}$$

$$V_0(n) = V(n) = \frac{1}{3 - n^2(0.22) + j1.39n} \quad I_0(n) = \frac{V_0(n)}{12}$$

$$V_{DC} = 50 \quad V_{0DC} = \frac{50}{3} \quad I_{0DC} = \frac{50}{36} = 1.39$$

$$V(1) = 25 \quad \theta_1 = -45^\circ \quad V_0(1) = 8.04 \angle -71.6^\circ \quad I_0(1) = 0.67 \angle -71.6^\circ$$

$$V(2) = 12.5 \quad \theta_2 = 45^\circ \quad V_0(2) = 3.58 \angle -7.67^\circ \quad I_0(2) = 0.30 \angle -7.67^\circ$$

$$P = \left(\frac{50}{3}\right) 1.39 + \frac{(8.04)(0.67)}{2} + \frac{(3.58)(0.30)}{2} = 26.40 \text{ W}$$

Problem 14.31

Determine the Fourier transform of the waveform shown.

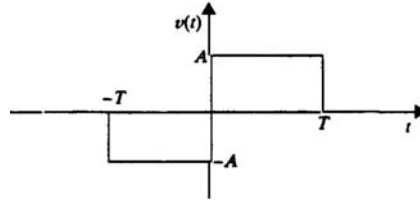

Suggested Solution

$$F(\omega) = \int_{-\infty}^{\infty} f(t)e^{-j\omega t} dt$$

$$V(\omega) = \int_{-T}^0 -Ae^{-j\omega t} dt + \int_0^T Ae^{-j\omega t} dt = \frac{A}{j\omega} \left\{ e^{-j\omega t} \Big|_{-T}^0 + e^{-j\omega t} \Big|_0^T \right\}$$

$$V(\omega) = \frac{A}{j\omega} \{1 - e^{-j\omega T} + 1 - e^{-j\omega T}\} = \frac{2A}{j\omega} \{1 - \cos(\omega T)\}$$

Problem 14.32

Derive the Fourier transform for the following functions:

(a) $f(t) = e^{-2t} \cos 4t u(t)$.

(b) $f(t) = e^{-2t} \sin 4t u(t)$.

Suggested Solution

PART A

$$f(t) = e^{-2t} \cos(4t)u(t)$$

$$F(\omega) = \int_0^{\infty} e^{-2t} \cos(4t) e^{-j\omega t} dt = \frac{1}{2} \int_0^{\infty} \left(e^{-(2-j4+j\omega)t} + e^{-(2+j4+j\omega)t} \right) dt$$

$$F(\omega) = \frac{1}{2} \left[\frac{e^{-(2-j4+j\omega)t}}{2-j4+j\omega} \Big|_0^{\infty} + \frac{e^{-(2+j4+j\omega)t}}{2+j4+j\omega} \Big|_0^{\infty} \right] = \frac{2+j\omega}{(2+j\omega-j4)(2+j\omega+j4)}$$

$$F(\omega) = \frac{2+j\omega}{(2+j\omega)^2 + 16}$$

PART B

$$f(t) = e^{-2t} \sin(4t)u(t) = \frac{1}{j2} \left[e^{-(2-j4)t} - e^{-(2+j4)t} \right] u(t)$$

$$F(\omega) = \frac{1}{j2} \int_0^{\infty} \left(e^{-(2-j4+j\omega)t} - e^{-(2+j4+j\omega)t} \right) dt$$

$$F(\omega) = \frac{1}{j2} \left[\frac{e^{-(2-j4+j\omega)t}}{2-j4+j\omega} \Big|_0^{\infty} - \frac{e^{-(2+j4+j\omega)t}}{2+j4+j\omega} \Big|_0^{\infty} \right] = \frac{1}{j2} \left[\frac{j8}{(2+j\omega-j4)(2+j\omega+j4)} \right]$$

$$F(\omega) = \frac{4}{(2+j\omega)^2 + 16}$$

Problem 14.33

Show that

$$F[f_1(t)f_2(t)] = \frac{1}{2\pi} \int_{-\infty}^{\infty} F_1(x)F_2(\omega - x)dx$$

Suggested Solution

$$\text{Let } G = \frac{1}{2\pi} \int_{-\infty}^{\infty} F_1(x)F_2(\omega - x) dx$$

$$F^{-1}[G] = \frac{1}{(2\pi)^2} \int_{x=-\infty}^{\infty} F_1(x) \int_{\omega=-\infty}^{\infty} F_2(\omega - x) e^{j\omega t} d\omega dx \text{ let } u = \omega - x \text{ and } du = d\omega$$

$$F^{-1}[G] = \frac{1}{(2\pi)^2} \int_{x=-\infty}^{\infty} F_1(x) \int_{u=-\infty}^{\infty} F_2(u) e^{ju t} e^{jxt} du dx$$

$$F^{-1}[G] = \frac{1}{(2\pi)^2} \int_{x=-\infty}^{\infty} F_1(x) e^{jxt} dx \int_{u=-\infty}^{\infty} F_2(u) e^{ju t} du = f_1(t) f_2(t)$$

$$F[f_1(t)f_2(t)] = G = \frac{1}{2\pi} \int_{-\infty}^{\infty} F_1(x)F_2(\omega - x) dx$$

Problem 14.34

Find the Fourier transform of the function $f(t) = e^{-a|t|}$.

Suggested Solution

$$f(t) = e^{-a|t|} \quad F(\omega) = \int_{-\infty}^{\infty} f(t) e^{-j\omega t} dt = \int_{-\infty}^0 e^{(a-j\omega)t} dt + \int_0^{\infty} e^{-(a-j\omega)t} dt$$

$$F(\omega) = \frac{e^{(a-j\omega)t}}{a-j\omega} \Big|_{-\infty}^0 + \frac{e^{-(a-j\omega)t}}{a+j\omega} \Big|_0^{\infty} = \frac{1}{a-j\omega} + \frac{1}{a+j\omega} = \frac{2a}{a^2 + \omega^2}$$

Problem 14.35

Find the Fourier transform of the function $f(t) = 12e^{-2|t|} \cos 4t$.

Suggested Solution

$$f(t) = 12e^{-2|t|} \cos 4t \quad \text{Let } g(t) = 12e^{-2|t|}$$

$$\text{From table 14.3,} \quad F[g(t) \cos \omega_0 t] = \frac{1}{2} [G(\omega - \omega_0) + G(\omega + \omega_0)]$$

$$\text{AND,} \quad G(\omega) = \frac{48}{4 + \omega^2}$$

$$F(\omega) = \frac{1}{2} \left[\frac{48}{4 + (\omega - 4)^2} + \frac{48}{4 + (\omega + 4)^2} \right] = \frac{24}{4 + (\omega - 4)^2} + \frac{24}{4 + (\omega + 4)^2}$$

Problem 14.36

Determine the output signal $v_o(t)$ of a network with input signal $v_i(t) = 3e^{-t}u(t)$ and network impulse response $h(t) = e^{-2t}u(t)$. Assume that all initial conditions are zero.

Suggested Solution

$$v_i(t) = 3e^{-t}u(t) \quad V_i(\omega) = \frac{3}{1+j\omega}$$

$$h(t) = e^{-2t}u(t) \quad H(\omega) = \frac{1}{2+j\omega}$$

$$V_o(\omega) = V_i(\omega)H(\omega) = \frac{3}{(1+j\omega)(2+j\omega)} = \frac{3}{1+j\omega} - \frac{3}{2+j\omega}$$

$$v_o(t) = 3(e^{-t} - e^{-2t})u(t)$$

Problem 14.37

The input signal to a network is $v_i(t) = e^{-3t} u(t)$. The transfer function of the network is $\mathbf{H}(j\omega) = 1/(j\omega + 4)$. Find the output of the network $v_o(t)$ if the initial conditions are zero.

Suggested Solution

$$v_i(t) = e^{-3t} u(t) \Rightarrow V_i(\omega) = \frac{1}{3 + j\omega}$$

$$H(j\omega) = \frac{1}{4 + j\omega}$$

$$V_o(\omega) = V_i(\omega) H(\omega) = \frac{3}{(3 + j\omega)(4 + j\omega)} = \frac{1}{3 + j\omega} - \frac{1}{4 + j\omega}$$

$$v_o(t) = (e^{-3t} - e^{-4t}) u(t)$$

Problem 14.38

The input signal for the network shown is $v_i(t) = 10e^{-5t}u(t)$ V. Determine the total 1- Ω energy content of the output $v_o(t)$.

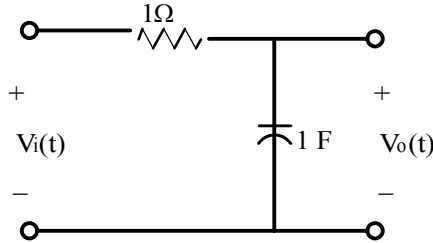

Suggested Solution

$$v_i(t) = 10e^{-5t}u(t) \Rightarrow V_i(\omega) = \frac{10}{5 + j\omega}$$

$$H(\omega) = \frac{1}{1 + \frac{1}{j\omega}} \quad V_o = \frac{10}{(1 + j\omega)(5 + j\omega)}$$

$$|V_o(\omega)|^2 = \frac{100}{(1 + \omega^2)(25 + \omega^2)} = \frac{100}{24} \frac{1}{1 + \omega^2} - \frac{100}{24} \frac{1}{25 + \omega^2}$$

$$W = \frac{1}{2\pi} \int_{-\infty}^{\infty} |V_o(\omega)|^2 d\omega = \frac{25}{12\pi} \left(\int_{-\infty}^{\infty} \frac{d\omega}{1 + \omega^2} - \int_{-\infty}^{\infty} \frac{d\omega}{25 + \omega^2} \right)$$

$$W = \frac{25}{12\pi} \left\{ \tan^{-1}(\omega) \Big|_{-\infty}^{\infty} - \frac{1}{5} \tan^{-1}\left(\frac{\omega}{5}\right) \Big|_{-\infty}^{\infty} \right\} = \frac{25}{12\pi} \left[\pi - \frac{\pi}{5} \right] = \frac{5}{3} J$$

Problem 14.39

Use the Fourier transform to find $i(t)$ in the network shown if $v_i(t) = 2e^{-t}u(t)$.

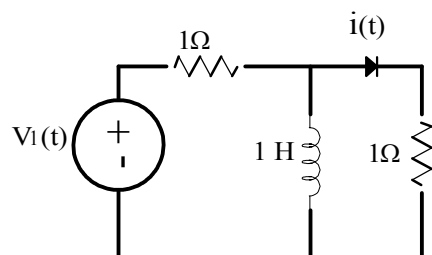

Suggested Solution

$$Z = j\omega \parallel 1 = \frac{j\omega}{1+j\omega} \quad V = V_i \frac{Z}{Z+1} = V_i \left(\frac{j\omega}{1+2j\omega} \right)$$

$$V_i = \frac{2}{1+j\omega} \quad I = \frac{V}{1} = \frac{j\omega}{(1+j\omega)(1/2+j\omega)}$$

$$I = \frac{2}{1+j\omega} - \frac{1}{\frac{1}{2}+j\omega}$$

$$i(t) = 2e^{-t} - e^{-\frac{t}{2}}u(t) \text{ A}$$

Problem 14.40

Determine the voltage $v_o(t)$ in the circuit shown, using the Fourier transform if $v_i(t) = 2e^{-4t}u(t)$.

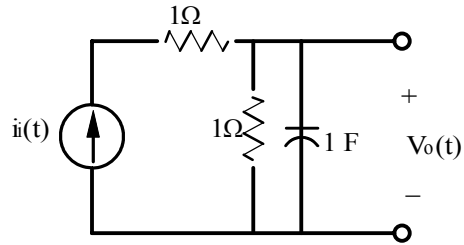

Suggested Solution

$$\frac{V_0}{I_i} = \frac{1}{j\omega} \parallel 1 = \frac{1}{j\omega + 1} = H(\omega)$$

$$V_0 = \frac{2}{(j\omega + 1)(j\omega + 4)}$$

$$V_0 = \frac{\frac{2}{3}}{j\omega + 1} - \frac{\frac{2}{3}}{j\omega + 4}$$

$$v_o(t) = \frac{2}{3} [e^{-t} - e^{-4t}] u(t) \text{ V}$$

Problem 14.41

Compute the 1- Ω energy content of the signal $v_o(t)$ in Problem 14.38 in the frequency range from $\omega = 2$ to $\omega = 4$ rad/s.

Suggested Solution

FROM 14.38

$$W = \frac{25}{12\pi} \left\{ \tan^{-1}(\omega) \Big|_2^4 - \frac{1}{5} \tan^{-1}\left(\frac{\omega}{5}\right) \Big|_2^4 \right\} = 0.106J$$

Problem 14.42

Determine the 1- Ω energy content of the signal $v_o(t)$ in Problem 14.38 in the frequency range from 0 to 1 rad/s.

Suggested Solution

FROM 14.38

$$W = \frac{25}{12\pi} \left\{ \tan^{-1}(\omega) \Big|_0^1 - \frac{1}{5} \tan^{-1}\left(\frac{\omega}{5}\right) \Big|_0^1 \right\} = 0.50J$$

Problem 14FE-1

Given the waveform shown, determine which of the trigonometric Fourier coefficients have zero value, which have nonzero value and why.

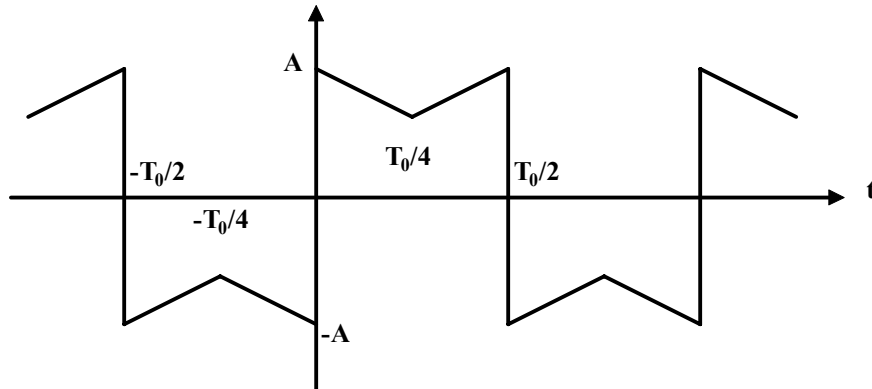

Suggested Solution

- $a_0=0$ Average value is zero
- $a_n=0$ for all n since this is an odd function
- $b_n=0$ n -even because of halfwave symmetry
- b_n =finite number for n -odd

Problem 14FE-2

Given the waveform shown, describe the type of symmetry and its impact on the trigonometric coefficients in the Fourier series, i.e. a_0 , a_n , b_n .

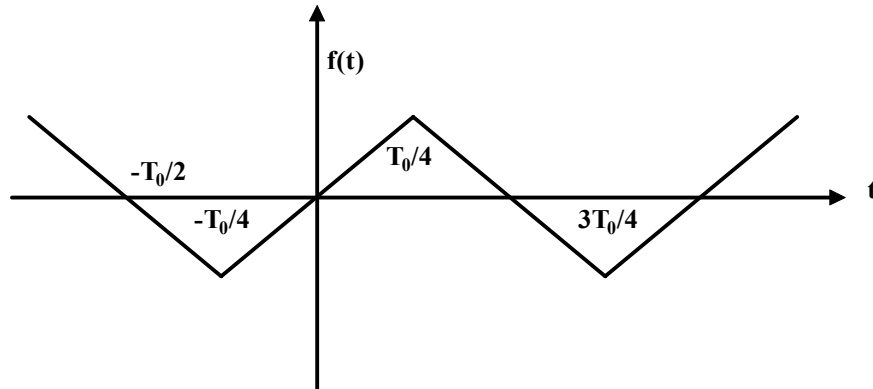

Suggested Solution

- $a_0=0$ Average value is zero
- $a_n=0$ for all n since this is an odd function
- $b_n=0$ n -even because of halfwave symmetry
- b_n =finite number for n -odd

Problem 15.1

Given the two networks shown, find the Y parameters for the circuit in (a) and Z parameters for the circuit in (b).

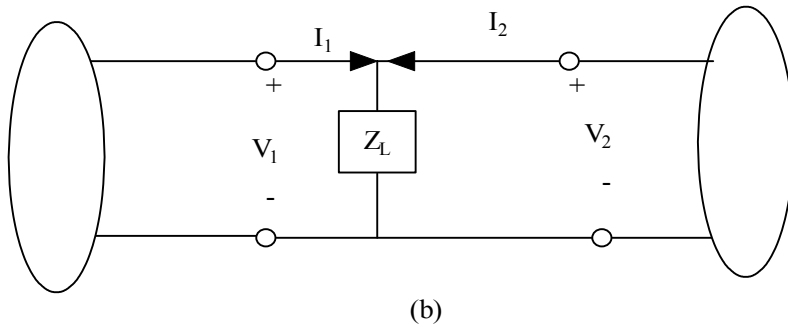
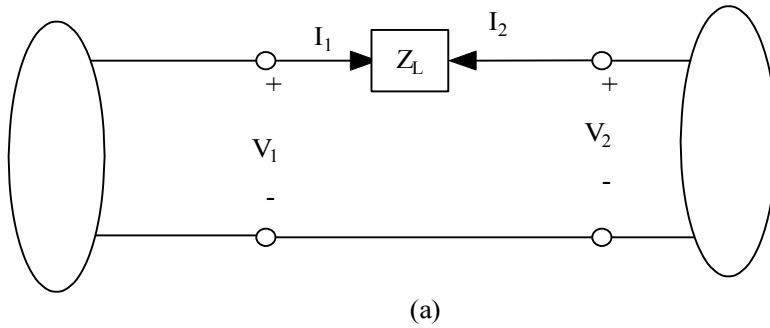

Suggested Solution

(a)

$$Y_{11} = \left. \frac{I_1}{V_1} \right|_{V_2=0} = \frac{1}{Z_L}$$

$$Y_{12} = \left. \frac{I_1}{V_2} \right|_{V_1=0} = 0 = -\frac{1}{Z_L}$$

$$Y_{21} = \left. \frac{I_2}{V_1} \right|_{V_2=0} = -\frac{1}{Z_L}$$

$$Y_{22} = \left. \frac{I_2}{V_2} \right|_{V_1=0} = \frac{1}{Z_L}$$

(b)

$$Z_{11} = \left. \frac{V_1}{I_1} \right|_{I_2=0} = Z_L$$

$$Z_{12} = \left. \frac{V_1}{I_2} \right|_{I_1=0} = Z_L$$

$$Z_{21} = \left. \frac{V_2}{I_1} \right|_{I_2=0} = Z_L$$

$$Z_{22} = \left. \frac{V_2}{I_2} \right|_{I_1=0} = Z_L$$

Problem 15.2

Find the Y parameters for the two-port network shown .

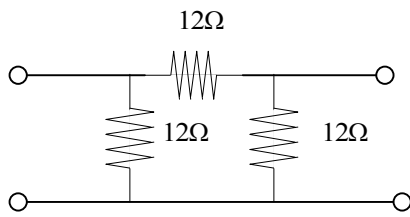

Suggested Solution

$$Y_{11} = \left. \frac{I_1}{V_2} \right|_{V_2=0} = \frac{S}{6} \qquad Y_{21} = \left. \frac{I_2}{V_1} \right|_{V_2=0} = -\frac{S}{12}$$
$$Y_{12} = \left. \frac{I_1}{V_2} \right|_{V_1=0} = -\frac{S}{12} \qquad Y_{22} = \left. \frac{I_2}{V_2} \right|_{V_1=0} = \frac{S}{6}$$

Problem 15.3

Find the Y parameters for the two-port network shown.

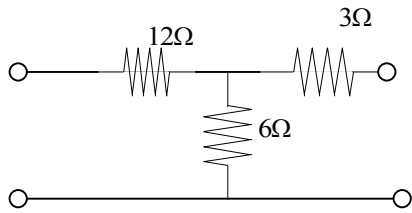

Suggested Solution

$$Y_{11} = \left. \frac{I_1}{V_2} \right|_{V_2=0} = \frac{1}{12 + 3 \parallel 6} = \frac{S}{14}$$

$$Y_{12} = \left. \frac{I_1}{V_2} \right|_{V_1=0} = I_1, \text{ when } V_2 = 1, \frac{1-V}{3} = \frac{V}{6 \parallel 12}, V = \frac{4}{7}$$

$$\text{So, } I_1 = \frac{-4/7}{12\Omega} = \frac{-1}{21} A$$

$$Y_{12} = \frac{-1}{21} S$$

$$C = \left. \frac{I_2}{V_1} \right|_{V_2=0} = I_2, \text{ When } V_1 = 1, \frac{1-V}{12} = \frac{V}{3 \parallel 6}, V = \frac{1}{7}$$

$$\text{So, } I_2 = \frac{-V/7}{3\Omega} = \frac{-A}{21}, Y_{21} = \frac{-S}{21}$$

$$Y_{22} = \left. \frac{I_2}{V_2} \right|_{V_1=0} = \frac{1}{3 + 6 \parallel 12} = \frac{S}{7}$$

Problem 15.4

If a 12-A source is connected at the input port of the network shown, find the current in a 4-ohm load resistor.

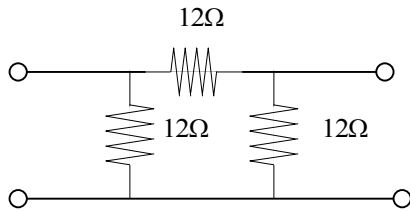

Suggested Solution

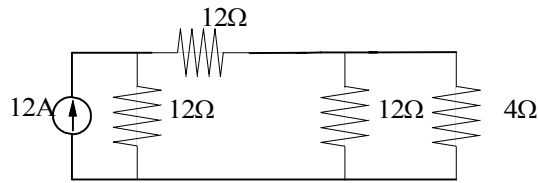

The equations for the two-port are: $\begin{bmatrix} I_1 \\ I_2 \end{bmatrix} = \begin{bmatrix} 1/6 & -1/12 \\ -1/12 & 1/6 \end{bmatrix} \begin{bmatrix} V_1 \\ V_2 \end{bmatrix}$, But the terminal conditions are

$$I_1 = 12A, I_2 = \frac{-V_2}{4}, \therefore \begin{aligned} 12 &= \frac{1}{6}V_1 - \frac{1}{12}V_2 \Rightarrow V_2 = 16V, I_2 = -4A \\ 0 &= -\frac{1}{12}V_1 + \frac{5}{12}V_2 \end{aligned}$$

$$V_2 = 16V, I_2 = -4A$$

Problem 15.5

Find the Y parameters for the two-port network shown.

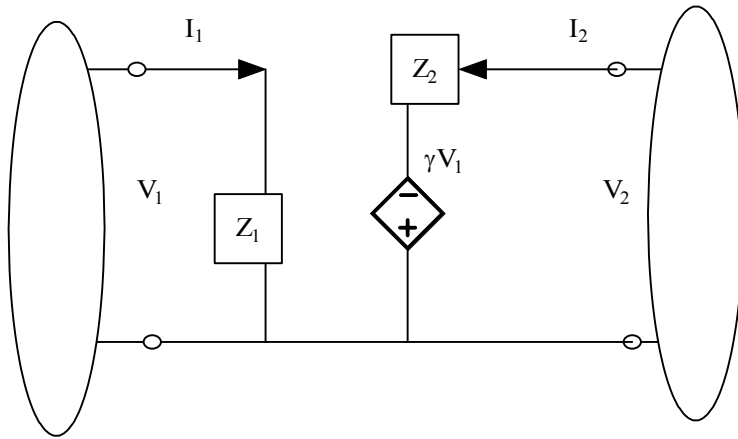

Suggested Solution

$$\begin{aligned}
 Y_{11} &= \left. \frac{I_1}{V_1} \right|_{V_2=0} = \frac{1}{21} \\
 Y_{12} &= \left. \frac{I_1}{V_2} \right|_{V_1=0} = 0 \\
 Y_{22} &= \left. \frac{I_2}{V_2} \right|_{V_1=0} = \frac{1}{Z_2} \\
 Y_{21} &= \left. \frac{I_2}{V_1} \right|_{V_2=0} = \frac{8}{Z_2}
 \end{aligned}$$

Problem 15.6

Determine the Y parameters for the network shown.

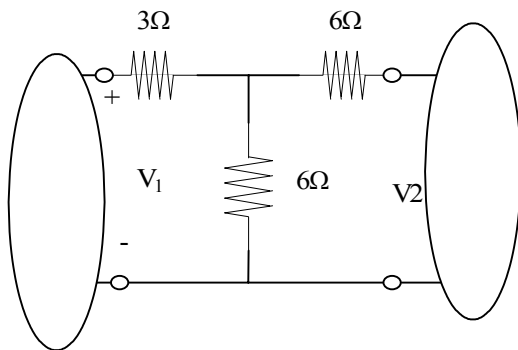

Suggested Solution

$$Y_{11} = \left. \frac{I_1}{V_1} \right|_{V_2=0} = \frac{1}{3+6 \parallel 6} = \frac{1}{6} S$$

$$Y_{12} = \left. \frac{I_1}{V_2} \right|_{V_1=0} = I_1, \text{ WHEN } V_2 = 1, \frac{V_2 - V}{6} = \frac{V}{6 \parallel 3}, V = \frac{1}{4}$$

$$\text{THEN, } I_1 = \frac{-V/4}{3\Omega} = \frac{-1}{12} A \text{ and } Y_{12} = \frac{-1}{12} S$$

$$Y_{21} = \left. \frac{I_2}{V_1} \right|_{V_2=0} = I_2, \text{ WHEN } V_1 = 1, \frac{1-V}{3} = \frac{V}{6 \parallel 6}, V = \frac{1}{2} \text{ THEN, } I_2 = \frac{-V/2}{6\Omega} = \frac{-1}{12}, Y_{21} = \frac{-1}{12}$$

$$Y_{22} = \left. \frac{I_2}{V_2} \right|_{V_1=0} = \frac{1}{6+3 \parallel 6} = \frac{1}{8} S$$

Problem 15.7

Determine the admittance parameters for the network shown.

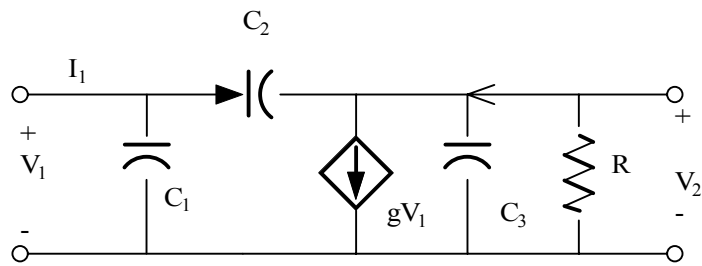

Suggested Solution

$$Y_{11} = j\omega(C_1 + C_2), Y_{21} = g - j\omega C_2$$

$$Y_{12} = -j\omega C_2, Y_{22} = \frac{1}{R} + j\omega(C_2 + C_3)$$

Problem 15.8

Find the Z parameters of the two port network shown.

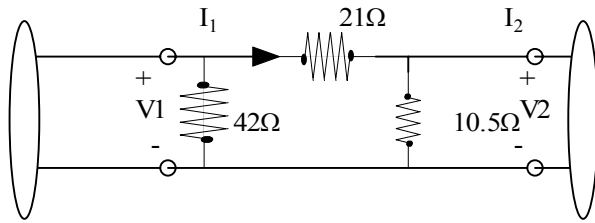

Suggested Solution

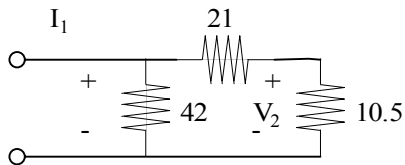

$$Z_{11} = \left. \frac{V_1}{I_1} \right|_{I_2=0} = \frac{(42)(31.5)}{42 + 31.5} = 18\Omega$$

$$Z_{21} = \left. \frac{V_2}{I_1} \right|_{I_2=0}$$

$$V_2 = \frac{10.5V_1}{21 + 10.5} = \frac{10.5}{31.5}(18I_1)$$

$$V_2 = 6I_1 \Rightarrow Z_{21} = 6\Omega$$

$$Z_{22} = \left. \frac{V_2}{I_2} \right|_{I_1=0} = \frac{(10.5)(63)}{42 + 31.5} = 9\Omega$$

$$Z_{12} = \left. \frac{V_1}{I_2} \right|_{I_1=0} = \frac{(42/63)(V_2)}{I_2} = \frac{2}{3}Z_{22} = 6\Omega$$

Problem 15.9

Find Z parameters of the network in Problem 15.5.

Suggested Solution

$$Z_{11} = \left. \frac{V_1}{I_1} \right|_{I_2=0} = Z_1, Z_{12} = \left. \frac{V_1}{I_2} \right|_{I_1=0} = 0$$

$$Z_{21} = \left. \frac{V_2}{I_1} \right|_{I_2=0} = -\gamma Z_1, Z_{22} = \left. \frac{V_2}{I_2} \right|_{I_1=0} = Z_2$$

Problem 15.10

Determine the Z parameters for the two port network shown.

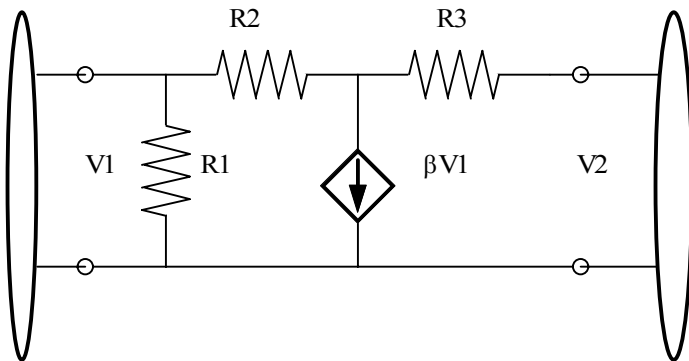

Suggested Solution

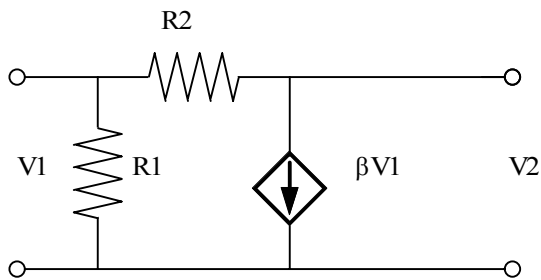

$$I_2 = 0$$

$$I_1 = \frac{V_1}{R_1} + \beta V_1$$

$$I_1 = \left(\frac{1}{R_1} + \beta\right)V_1$$

$$I_1 = \left(\frac{1 + \beta R_1}{R_1}\right)V_1 \Rightarrow Z_{11} = \frac{R_1}{1 + \beta R_1}$$

$$V_2 = V_1 - \beta V_1 R_2 \Rightarrow V_2 = V_1(1 - \beta R_2) = (1 - \beta R_2)\left(\frac{R_1}{1 + \beta R_1}\right)I_1$$

$$Z_{21} = \frac{R_1(1 - \beta R_2)}{1 + \beta R_1}$$

$$Z_{21} = \frac{R_1(1 - \beta R_2)}{1 + \beta R_1}$$

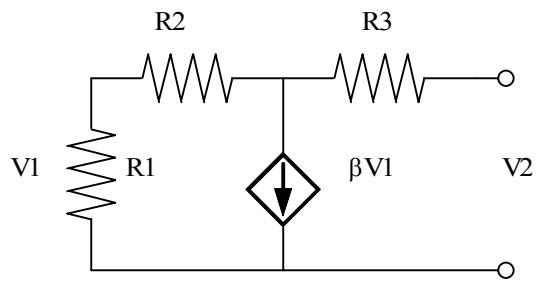

$$I_1 = 0$$

$$I_2 = \frac{V_1}{R_1} + \beta V_1$$

$$I_2 = \left(\frac{1}{R_1} + \beta\right)V_1 = \left(\frac{1 + \beta R_1}{R_1}\right)V_1 \Rightarrow V_1 = \frac{R_1}{1 + \beta R_1} I_2$$

$$Z_{12} = \frac{R_1}{1 + \beta R_1}$$

$$V_2 = I_2 R_3 + \left(\frac{V_1}{R_1}\right)R_2 + V_1 = I_2 R_3 + V_1 \left(\frac{R_2}{R_1} + 1\right)$$

Problem 15.11

Find the Z parameters for the two port shown. Determine the voltage gain of the entire circuit with a 4k-ohm load attached.

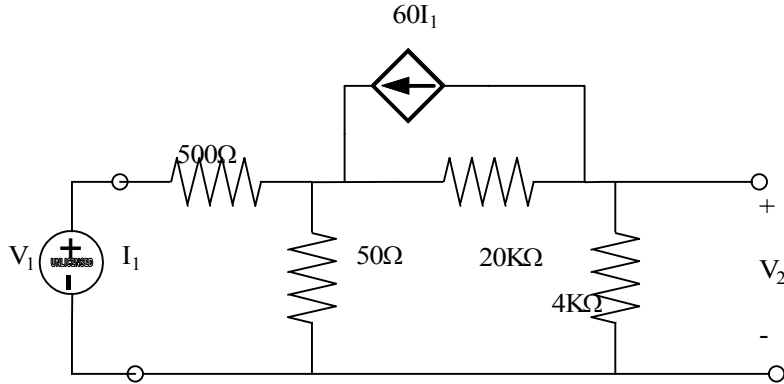

Suggested Solution

$$Z_{11} = 550, Z_{21} \Rightarrow V_2 = 50I_1 - 60(20K)I_1 \Rightarrow Z_{21} = 1200K$$

$$Z_{12} = 50, Z_{22} = 20K + 50 = 20K$$

$$I_2 = \frac{-V_0}{4K}, V_2 = V_0$$

$$V_1 = 550I_1 + 50I_2$$

$$V_2 = -1200KI_1 + 20KI_2$$

$$V_1 = 550 - \frac{50}{4K}V_0$$

$$V_0 = -1200KI_1 - \frac{20K}{4K}V_0$$

$$550I_1 = V_1 + 0.0125V_0$$

$$1200KI_1 = -V_0 - 5V_0$$

$$1200KI_1 = 2181.82V_1 + 2727V_0$$

$$1200KI_1 = -6V_0$$

$$\therefore -6V_0 = 2181.82V_1 + 27.27V_0 \Rightarrow -33.27V_0 = 2181.82V_1$$

$$\frac{V_0}{V_1} = -65.6$$

$$\frac{V_0}{V_1} = -65.6$$

Problem 15.12

Find the Z parameters for the two port network shown.

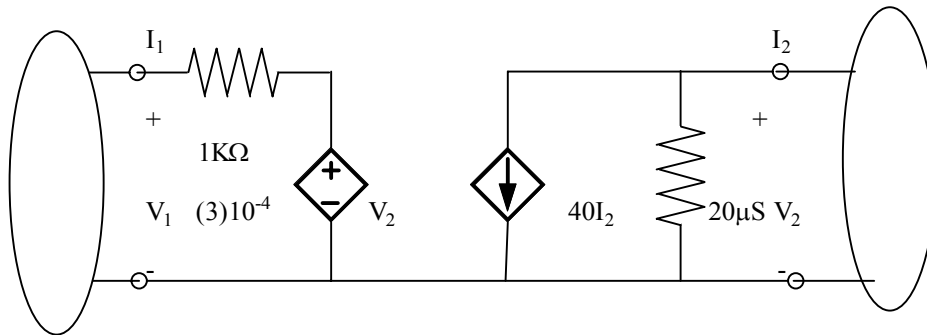

Suggested Solution

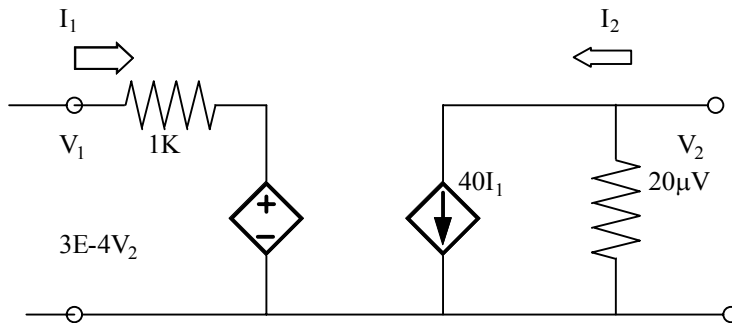

$$h_{11} = 1K, h_{21} = 40, h_{12} = 3E - v, h_{22} = 20\mu$$

$$\Delta H = h_{11}h_{22} - h_{12}h_{21} = 8E - 3$$

$$Z_{11} = \frac{\Delta h}{h_{22}} = \frac{8E - 3}{2E - 5} = 400\Omega$$

$$Z_{12} = \frac{h_{12}}{h_{22}} = \frac{3E - 4}{2E - 5} = 15\Omega$$

$$Z_{21} = \frac{-h_{21}}{h_{22}} = \frac{-40}{20\mu} = -2E - 6\Omega$$

$$Z_{22} = \frac{1}{h_{22}} = 50K\Omega$$

Problem 15.13

Find the voltage gain of the two port network in Problem 15.12 with a 12k-ohm load.

Suggested Solution

$$V_1 = 400I_1 + 15I_2$$

$$V_2 = -2 \times 10^{-6} I_1 + 50 \times 10^3 I_2$$

$$V_1 = 400I_1 - \frac{15V_2}{12K}$$

$$V_2 = -2 \times 10^6 I_1 - \frac{50 \times 10^3 V_2}{12 \times 10^3}$$

$$5000V_1 = 2 \times 10^6 - 6.25V_2$$

$$V_2 = -2 \times 10^6 I_1 - 4.17V_2$$

$$5000V_1 + V_2 = -10.42V_2 \Rightarrow -11.42 = 5000V_1 \Rightarrow \frac{V_2}{V_1} = -438$$

$$\frac{V_2}{V_1} = -438$$

Problem 15.14

Find the input impedance of the network in Problem 15.12

Suggested Solution

From problem 15.13 solution:

$$5000V_1 = 2 \times 10^6 I_1 - 6.25(-4.38V_1)$$

$$(5000 - 2737.5)V_1 = 2 \times 10^6 I_1 \Rightarrow Z_{in} = \frac{V_1}{I_1} = \frac{2 \times 10^6}{2262.5} = 884 \Omega$$

$$Z_{in} = 884 \Omega$$

Problem 15.15

Find the Z parameters of the two port network shown.

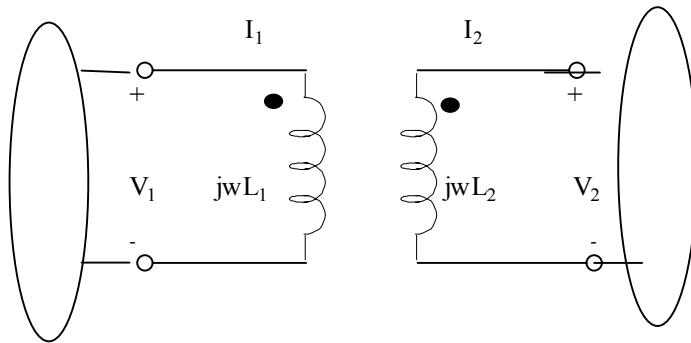

Suggested Solution

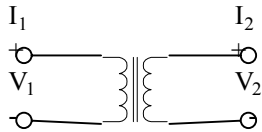

$$V_1 = I_1 j\omega L_1 + I_2 n j\omega$$

$$V_2 = I_1 n j\omega + I_2 j\omega L_2$$

$$Z_{11} = j\omega L_1, Z_{12} = j\omega n, Z_{21} = j\omega n, Z_{22} = j\omega L_2$$

$$Z_{11} = j\omega L_1, Z_{12} = j\omega n, Z_{21} = j\omega n, Z_{22} = j\omega L_2$$

Problem 15.16

Determine the Z parameters of the two port network shown.

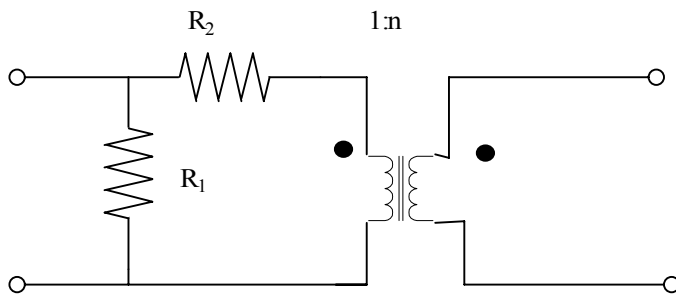

Suggested Solution

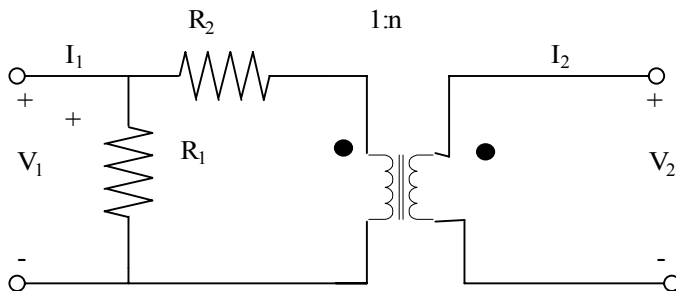

$$\begin{aligned}V_1 &= nI_2R_1 \\ \therefore Z_{12} &= nR_1 \\ Z_{11} &= R_1 \\ V_2 &= nR_1I_1 \\ \therefore Z_{21} &= nR_1 \\ Z_{22} &= n^2(R_1 + R_2)\end{aligned}$$

Problem 15.17

Compute the hybrid parameters for the network shown.

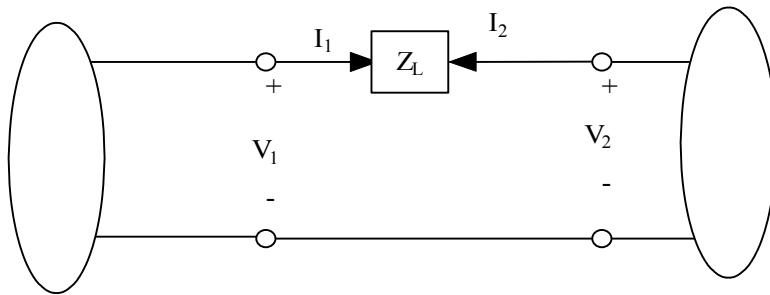

(a)

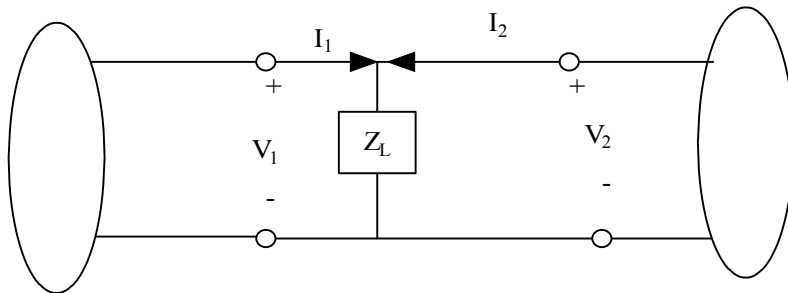

(b)

Suggested Solution

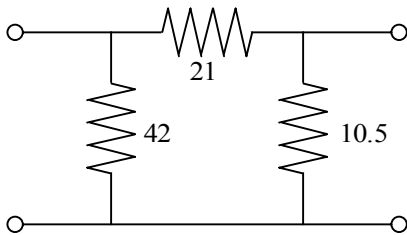

$$h_{11} = \left. \frac{V_1}{I_1} \right|_{V_2=0} = 21 \parallel 42 = 14 \Omega$$

$$h_{12} = \left. \frac{V_1}{V_2} \right|_{I_1=0} = \frac{42}{42+21} = \frac{2}{3}$$

$$h_{21} = \left. \frac{I_1}{I_2} \right|_{V_2=0} = \frac{-42}{42+21} = -\frac{2}{3}$$

$$h_{22} = \left. \frac{I_2}{V_2} \right|_{I_1=0} = \frac{1}{10.5 \parallel (21+42)} = \frac{1}{9} S$$

Problem 15.18

Consider the network shown. The two port network is a hybrid model of a basic transistor. Determine the voltage gain of entire network, V_2/V_S , if a source V_S with internal resistance R_1 is applied at the input to the two port and a load R_L is connected.

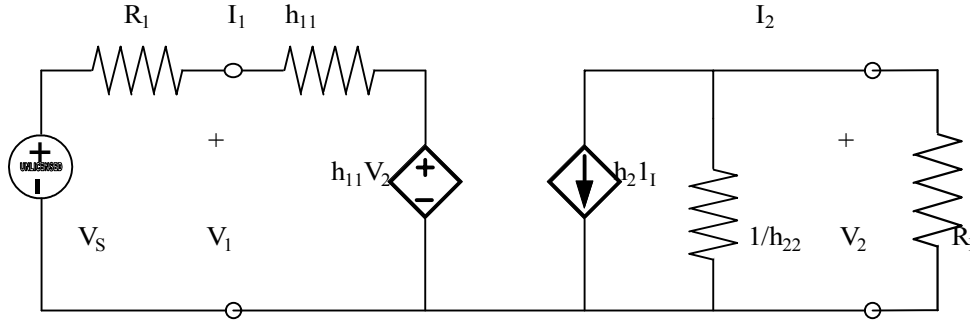

Suggested Solution

$$V_1 = h_{11}I_1 + h_{12}V_2$$

$$I_2 = h_{21}I_1 + h_{22}V_2$$

Also

$$V_2 = -R_L I_2 \text{ or } I_2 = \frac{-V_2}{R_L} \text{ and } V_1 = V_S - R_1 I_1$$

$$V_S - R_1 I_1 = h_{11}I_1 + h_{12}V_2$$

$$\frac{-V_2}{R_L} = h_{21}I_1 + h_{22}V_2$$

$$V_S = (R_1 + h_{11})I_1 + h_{12}V_2$$

$$h_{21}I_1 = -\left(h_{22} + \frac{1}{R_L}\right)V_2$$

$$I_1 = -\left(h_{22} + \frac{1}{R_L}\right)V_2 \frac{1}{h_{21}}$$

$$\therefore V_S = \left[h_{12} - \frac{1}{h_{21}}\left(h_{22} + \frac{1}{R_L}\right)(R_1 + h_{11})\right]V_2$$

$$V_S = \left[h_{12} - \frac{(1 + h_{22}R_L)(R_1 + h_{11})}{h_{21}R_L}\right]V_2$$

$$V_S = \left[\frac{h_{12}h_{21}R_L - (1 + h_{22}R_L)(R_1 + h_{11})}{h_{21}R_L}\right]V_2$$

$$\frac{V_2}{V_S} = \frac{h_{21}R_L}{h_{12}h_{21}R_L - (1 + h_{22}R_L)(R_1 + h_{11})}$$

Problem 15.19

Find the hybrid parameters for the network shown.

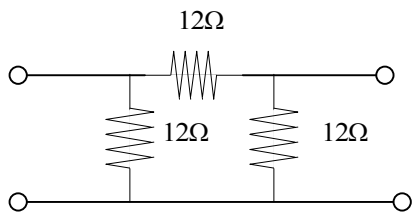

Suggested Solution

$$h_{11} = \left. \frac{V_1}{I_1} \right|_{V_2=0} = 12 \parallel 12 = 6\Omega$$

$$h_{12} = \left. \frac{V_1}{V_2} \right|_{I_1=0} = \frac{12}{12+12} = 0.5$$

$$h_{21} = \left. \frac{I_1}{I_2} \right|_{V_2=0} = \frac{-12}{12+12} = -0.5$$

$$h_{22} = \left. \frac{I_2}{V_2} \right|_{I_1=0} = \frac{1}{12 \parallel (12+12)} = \frac{1}{8} S$$

Problem 15.20

Determine the hybrid parameters for the network shown.

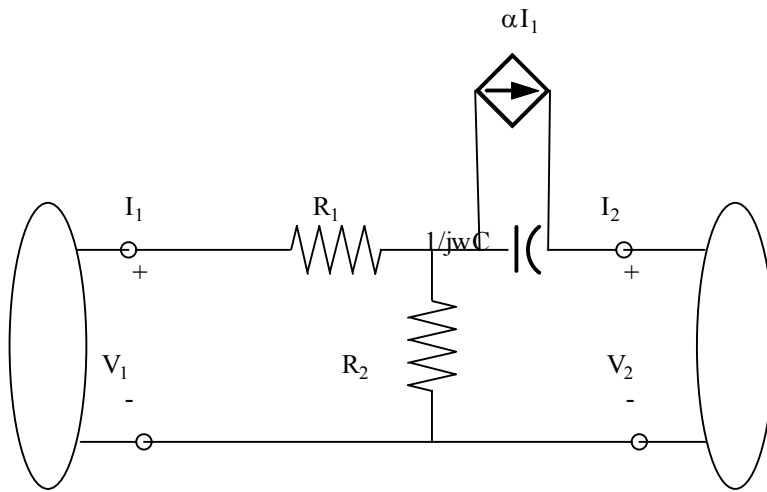

Suggested Solution

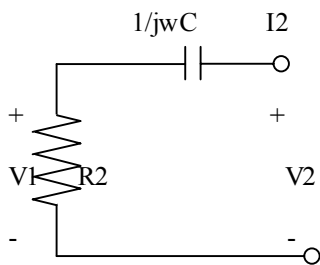

$$I_1 = 0$$

$$V_1 = \frac{R_2 V_2}{R_2 + \frac{1}{j\omega C}}$$

$$h_{12} = \frac{j\omega C R_2}{1 + j\omega C R_2}$$

$$I_2 = \frac{V_2}{R_2 + \frac{1}{j\omega C}} = \frac{j\omega C V_2}{1 + j\omega C R_2} \Rightarrow h_{22} = \frac{j\omega C}{1 + j\omega C R_2}$$

$$V_2 = 0$$

$$R_2(I_1 + I_2) + \frac{1}{j\omega C}(\alpha I_1 + I_2) = 0$$

$$(R_2 + \frac{\alpha}{j\omega C})I_1 + (R_2 + \frac{1}{j\omega C})I_2 = 0$$

$$(\alpha + j\omega R_2 C)I_1 = -(1 + j\omega R_2 C)I_2$$

$$I_2 = \left[\frac{-(\alpha + j\omega R_2 C)}{1 + j\omega R_2 C} \right] I_1$$

$$\therefore h_{21} = -\left(\frac{\alpha + j\omega R_2 C}{1 + j\omega R_2 C} \right)$$

$$V_1 = (R_1 + R_2)I_1 + R_2 I_2 = \left[R_1 + R_2 - \frac{R_2(\alpha + j\omega R_2 C)}{1 + j\omega R_2 C} \right] I_1$$

$$\therefore h_{11} = \frac{R_1 j\omega R_1 R_2 C + R_2 + j\omega R_2^2 C - \alpha R_2 - j\omega R_2^2 C}{1 + j\omega R_2 C}$$

$$h_{11} = \frac{R_1 + R_2(1 - \alpha) + j\omega R_1 R_2 C}{1 + j\omega R_2 C}$$

Problem 15.21

Find the ABCD parameters for the networks shown.

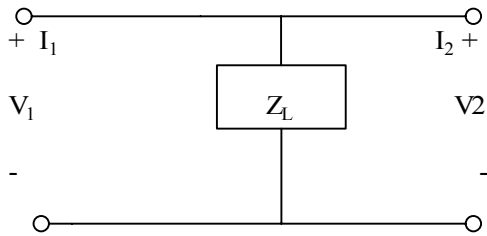
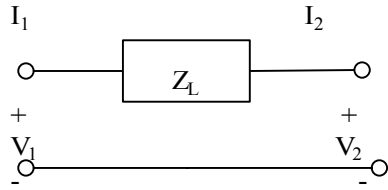

Suggested Solution

$$A = \left. \frac{V_1}{V_2} \right|_{I_2=0} = 1$$

$$B = \left. \frac{I_1}{-I_2} \right|_{V_2=0} = Z_2$$

$$C = \left. \frac{I_1}{V_2} \right|_{I_2=0} = 0$$

$$D = \left. \frac{I_1}{-I_2} \right|_{V_2=0} = 1$$

$$A = \left. \frac{V_1}{V_2} \right|_{I_2=0} = 1$$

$$B = 0$$

$$C = \frac{1}{Z_2}$$

$$D = 1$$

Problem 15.22

Find the transmission parameters for the network shown.

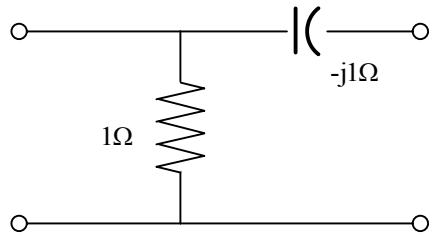

Suggested Solution

$$A = 1$$

$$B = -1j\Omega$$

$$C = 1s$$

$$\frac{1(I_1)}{1-j} = -I_2 \Rightarrow D = 1-j$$

Problem 15.23

Find the transmission parameters for the network shown.

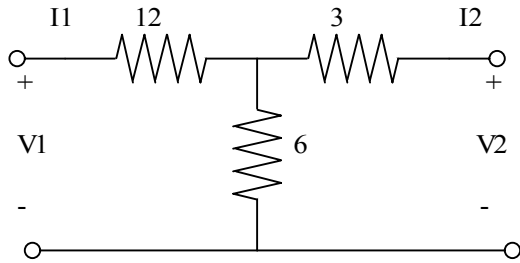

Suggested Solution

$$A = \left. \frac{V_1}{I_1} \right|_{I_2=0} = 3$$

$$C = \left. \frac{I_1}{V_2} \right|_{I_2=0} = \frac{I_1}{6I_1} = \frac{1}{6} S$$

$$B = \left. \frac{-V_1}{I_2} \right|_{V_2=0}$$

$$D = \left. \frac{-I_1}{I_2} \right|_{V_2=0} = \frac{-I_1}{\frac{6I_1}{9}} = \frac{3}{2}$$

$$I_1 = 1.5I_2$$

$$V_1 = 12I_1 + 6(I_1 + I_2) = 18I_1 + 6I_2 = -21I_2$$

$$B = \frac{-21I_2}{I_2} = 21\Omega$$

Problem 15.24

Find ABCD parameters for the network shown.

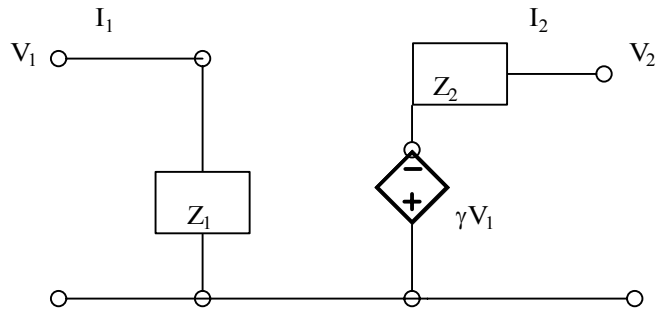

Suggested Solution

$$A = \left. \frac{V_1}{V_2} \right|_{I_2=0} = \frac{V_1}{\gamma V_1} = \frac{-1}{\gamma}$$

$$B = \left. \frac{V_1}{-I_2} \right|_{V_2=0} = \frac{V_1}{\frac{-(V_2 + \gamma V_1)}{Z_2}} = \frac{-Z_2}{\gamma}$$

$$C = \left. \frac{I_1}{V_2} \right|_{I_2=0} = \frac{I_1}{-\gamma V_2} = \frac{-1}{\gamma Z_1}$$

$$D = \left. \frac{I_1}{-I_2} \right|_{V_2=0} = \frac{I_1}{\frac{-\gamma V_1}{Z_2}} = \frac{-Z_2}{\gamma Z_1}$$

Problem 15.25

Determine the transmission parameters for the network shown.

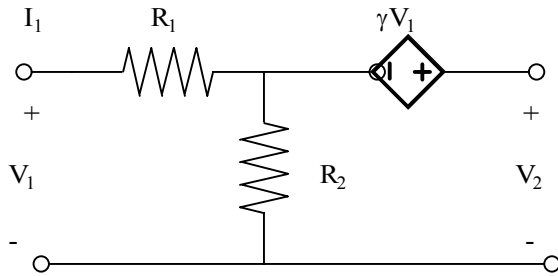

Suggested Solution

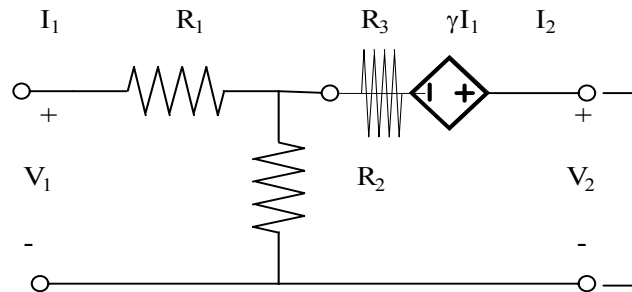

$$I_2 = 0$$

$$V_2 = (\gamma + R_2)I_1$$

$$C = \frac{1}{\gamma + R_2}$$

$$V_1 = (R_1 + R_2)I_1 \Rightarrow A = \frac{R_1 + R_2}{\gamma + R_2}$$

$$V_2 = 0$$

$$\gamma I_1 + (R_3 + R_2)I_2 + R_2 I_1 = 0$$

$$(\gamma + R_2)I_1 = -(R_3 + R_2)I_2$$

$$I_1 = -\left(\frac{R_3 + R_2}{\gamma + R_2}\right)I_2 \Rightarrow D = \frac{R_3 + R_2}{\gamma + R_2}$$

$$V_1 = (R_1 + R_2)I_1 + R_2 I_2 = -\left(\frac{R_3 + R_2}{\gamma + R_2}\right)(R_1 + R_2)I_2 + R_2 I_2$$

$$V_1 = -\left[\frac{(R_3 + R_2)(R_1 + R_2)}{\gamma + R_2} - R_2\right]I_2$$

$$\therefore B = \frac{R_3 R_1 + R_3 R_2 + R_2 R_1 + R_2^2 - \gamma R_2 - R_2^2}{\gamma + R_2} = \frac{R_3 R_1 + R_3 R_2 + R_2 R_1 - \gamma R_2}{\gamma + R_2}$$

$$\frac{R_3 R_1 + R_3 R_2 + R_2 R_1 - \gamma R_2}{\gamma + R_2}$$

Problem 15.26

Find the transmission parameters for the circuit shown.

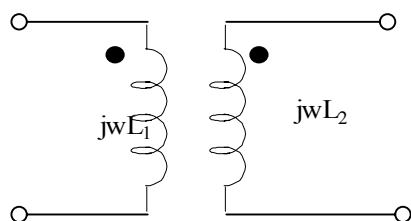

Suggested Solution

$$\text{For } I_2 = 0, I_1 = \frac{V_1}{j\omega L_1}$$

AND

$$V_2 = j\omega M I_1$$

$$\therefore V_2 = \frac{j\omega M V_1}{j\omega L_1}, A = \frac{V_1}{V_2} = \frac{L_1}{M}$$

Since

$$V_2 = 0, V_1 = j\omega L_1 I_1 + j\omega M I_2$$

$$0 = j\omega M I_1 + j\omega L_2 I_2$$

$$\therefore I_1 = \frac{L_2}{M} (-I_2)$$

$$V_1 = -j\omega L_1 \left(\frac{L_1}{M}\right) (-I_2) - j\omega M (-I_2)$$

$$\therefore B = \frac{V_1}{-I_2} = j\omega \left[\frac{L_1 L_2 - M^2}{M} \right]$$

$$D = \frac{I_1}{-I_2} = \frac{L_2}{M}$$

$$\therefore \begin{bmatrix} A & B \\ C & D \end{bmatrix} = \begin{bmatrix} \frac{L_1}{M} & j\omega \frac{L_1 L_2 - M^2}{M} \\ \frac{1}{j\omega M} & \frac{L_2}{M} \end{bmatrix}$$

Problem 15.27

Find the transmission parameters for two port network and then find I_0 using the terminal conditions.

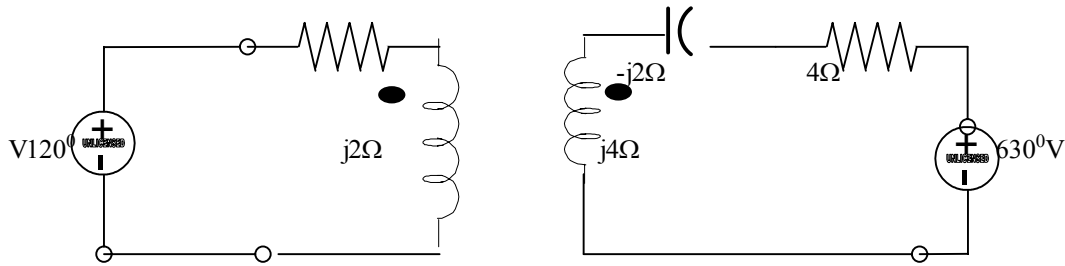

Suggested Solution

$$\Rightarrow \begin{bmatrix} 1 & 2 \\ 0 & 1 \end{bmatrix}$$

$$\Rightarrow \begin{bmatrix} 2 & j(8-1) \\ -j1 & 4 \end{bmatrix}$$

$$\Rightarrow \begin{bmatrix} 1 & 4-2j \\ 0 & 1 \end{bmatrix}$$

THEN

$$\begin{bmatrix} 1 & 2 \\ 0 & 1 \end{bmatrix} \begin{bmatrix} 2 & j(8-1) \\ -j1 & 4 \end{bmatrix} \begin{bmatrix} 1 & 4-2j \\ 0 & 1 \end{bmatrix} = \begin{bmatrix} 2-2j & 12-5j \\ -1j & 2-4j \end{bmatrix}$$

$$V_1 = 12\angle 0^\circ V$$

$$V_2 = 6\angle 30^\circ V$$

$$-I_2 = I_0$$

$$V_1 = AV_2 + B(-I_2)$$

$$12\angle 0^\circ = (2-2j)6\angle 30^\circ + (12-5j)I_0$$

Solving

$$I_0 = -0.48\angle -22.35^\circ A$$

Problem 15.28

Following are the hybrid parameters for a network.

$$\begin{bmatrix} h_{11} & h_{12} \\ h_{21} & h_{22} \end{bmatrix} = \begin{bmatrix} \frac{11}{5} & \frac{2}{5} \\ -\frac{2}{5} & \frac{1}{5} \end{bmatrix}$$

Determine the Y parameters of the network

Suggested Solution

Using Table 15.1

$$y_{11} = \frac{1}{h_{11}} = \frac{5s}{11}$$

$$y_{12} = \frac{-h_{12}}{h_{11}} = \frac{-2s}{11}$$

$$y_{21} = \frac{h_{21}}{h_{11}} = \frac{-2s}{11}$$

$$y_{22} = \frac{\Delta H}{h_{11}} = \frac{3s}{11}$$

Problem 15.29

If the Y parameters for a network are known to be

$$\begin{bmatrix} y_{11} & y_{12} \\ y_{21} & y_{22} \end{bmatrix} = \begin{bmatrix} \frac{5}{11} & \frac{-2}{11} \\ \frac{-2}{11} & \frac{3}{11} \end{bmatrix}$$

Find the Z parameters.

Suggested Solution

$$Y = \begin{bmatrix} \frac{5}{11} & \frac{-2}{11} \\ \frac{-2}{11} & \frac{3}{11} \end{bmatrix}$$

$$\Delta Y = \frac{3 \times 5}{|2|} - \frac{(-2)(-2)}{|2|} = y_{11}y_{22} - y_{21}y_{12} = \frac{1}{11}$$

Then

$$Z_{11} = \frac{y_{22}}{\Delta Y} = \frac{3/11}{1/11} = 3\Omega$$

$$Z_{12} = \frac{-y_{12}}{\Delta Y} = \frac{2/11}{1/11} = 2\Omega$$

$$Z_{21} = \frac{-y_{21}}{\Delta Y} = 2\Omega$$

$$Z_{22} = \frac{y_{11}}{\Delta Y} = 5\Omega$$

Problem 15.30

Find the Z parameters in terms of the ABCD parameters

Suggested Solution

The ABCD Parameters equations are:

$$V_1 = AV_2 - BI_2$$

$$I_1 = CV_2 - DI_2$$

\Rightarrow

$$V_2 = \frac{1}{C}[I_1 + DI_2]$$

$$V_1 = A\left[\frac{I_1}{C} + \frac{DI_2}{C}\right] - BI_2 = \frac{AI_1}{C} + \left(\frac{AD}{C} - B\right)I_2$$

$$Z_{11} = \frac{A}{C}$$

$$Z_{12} = \frac{AD - BC}{C}$$

$$Z_{21} = \frac{1}{C}$$

$$Z_{22} = \frac{D}{C}$$

Problem 15.31

Find the Hybrid parameters in terms of the Impedance parameters

Suggested Solution

$$V_1 = Z_{11}I_1 + Z_{12}I_2$$

$$V_2 = Z_{21}I_1 + Z_{22}I_2$$

$$I_2 = \frac{-Z_{21}}{Z_{22}}I_1 + \frac{V_2}{Z_{22}}$$

Substitute this value into the first equation yields

$$V_1 = \frac{Z_{11}Z_{22} - Z_{12}Z_{21}}{Z_{22}}I_1 + \frac{Z_{12}}{Z_{22}}V_2$$

$$h_{11} = \frac{\Delta Z}{Z_{22}}$$

$$h_{12} = \frac{Z_{12}}{Z_{22}}$$

$$h_{21} = \frac{-Z_{21}}{Z_{22}}$$

$$h_{22} = \frac{1}{Z_{22}}$$

Where

$$\Delta Z = Z_{11}Z_{22} - Z_{12}Z_{21}$$

Problem 15.32

Find the Y parameters of the network shown, by considering the network to be a parallel connection of two port networks.

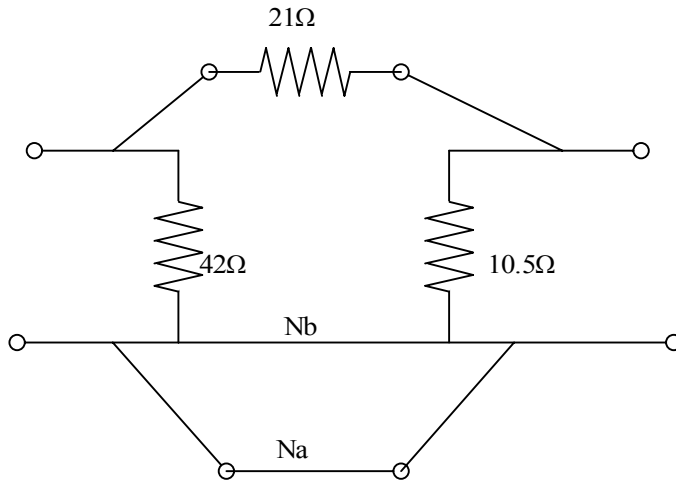

Suggested Solution

For NA

$$Y_A = \begin{bmatrix} \frac{1}{21} & -\frac{1}{21} \\ -\frac{1}{21} & \frac{1}{21} \end{bmatrix}$$

NB

$$Y_B = \begin{bmatrix} \frac{1}{42} & 0 \\ 0 & \frac{1}{10.5} \end{bmatrix}$$

$$Y_1 = Y_A + Y_B = \begin{bmatrix} \frac{1}{14} & -\frac{1}{21} \\ -\frac{1}{21} & \frac{1}{7} \end{bmatrix}$$

Problem 15.33

Find the Y parameters of the two port shown. Find the input admittance of the network when the capacitor is connected to the output port

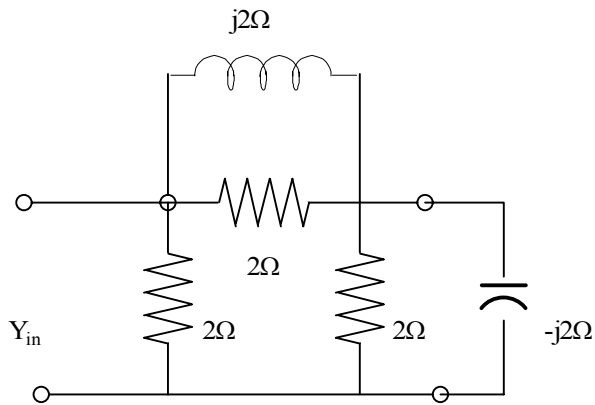

Suggested Solution

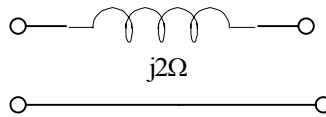
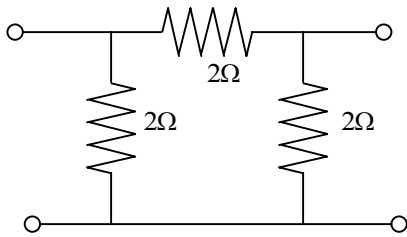

$$Y_1 = \begin{bmatrix} \frac{1}{j2} & -\frac{1}{j2} \\ -\frac{1}{j2} & \frac{1}{j2} \end{bmatrix}$$

$$Y_2 = \begin{bmatrix} 1 & -\frac{1}{2} \\ -\frac{1}{2} & 1 \end{bmatrix}$$

$$Y_T = \begin{bmatrix} 1 + \frac{1}{j2} & -\frac{1}{2} - \frac{1}{j2} \\ -\frac{1}{2} - \frac{1}{j2} & 1 + \frac{1}{j2} \end{bmatrix}$$

$$Y_{IN} = Y_{11} - \frac{Y_{12}Y_{21}}{Y_{22} + Y_L} = 1 - 0.5j - \left[\frac{\left(\frac{-1}{2} - \frac{1}{2j}\right)\left(-\frac{1}{2} - \frac{1}{2j}\right)}{1 - 0.5j + 0.5j} \right]$$

$$= 1s$$

Problem 15.34

Find the Y parameters for the network shown.

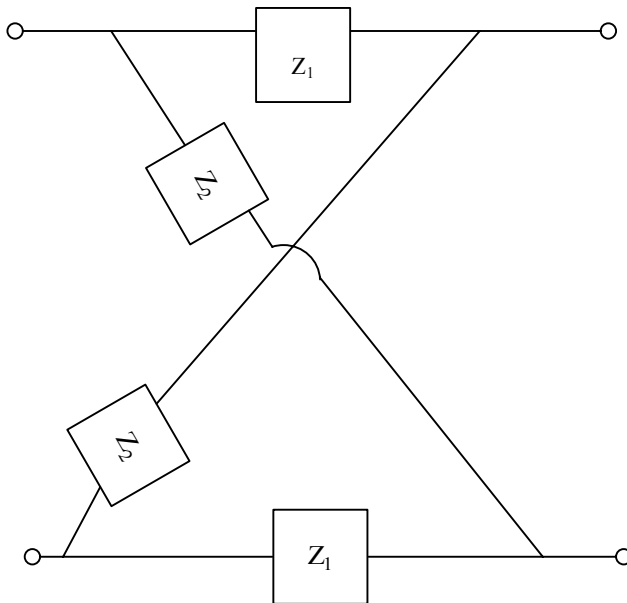

Suggested Solution

Use a parallel interconnection

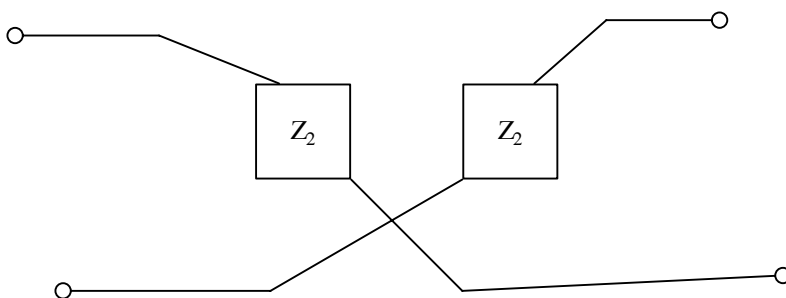
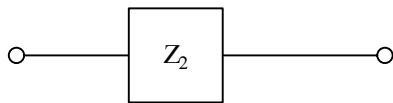
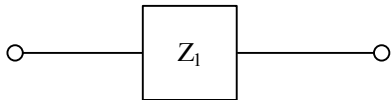

$$y_{11} = \frac{1}{2Z_1}$$

$$y_{12} = -\frac{1}{2Z_1}$$

$$y_{21} = -\frac{1}{2Z_1}$$

$$y_{22} = \frac{1}{2Z_1}$$

$$y_{11} = \frac{1}{2Z_2}$$

$$y_{12} = \frac{1}{2Z_2}$$

$$y_{21} = \frac{1}{2Z_2}$$

$$y_{22} = \frac{1}{2Z_2}$$

$$\begin{bmatrix} y_{11} & y_{12} \\ y_{21} & y_{22} \end{bmatrix}_{TOTAL} = \begin{bmatrix} \frac{1}{2Z_1} + \frac{1}{2Z_2} & \frac{-1}{2Z_1} + \frac{1}{2Z_2} \\ \frac{-1}{2Z_1} + \frac{1}{2Z_2} & \frac{1}{2Z_1} + \frac{1}{2Z_2} \end{bmatrix}$$

Problem 15.35

Determine the Y parameters for the network shown.

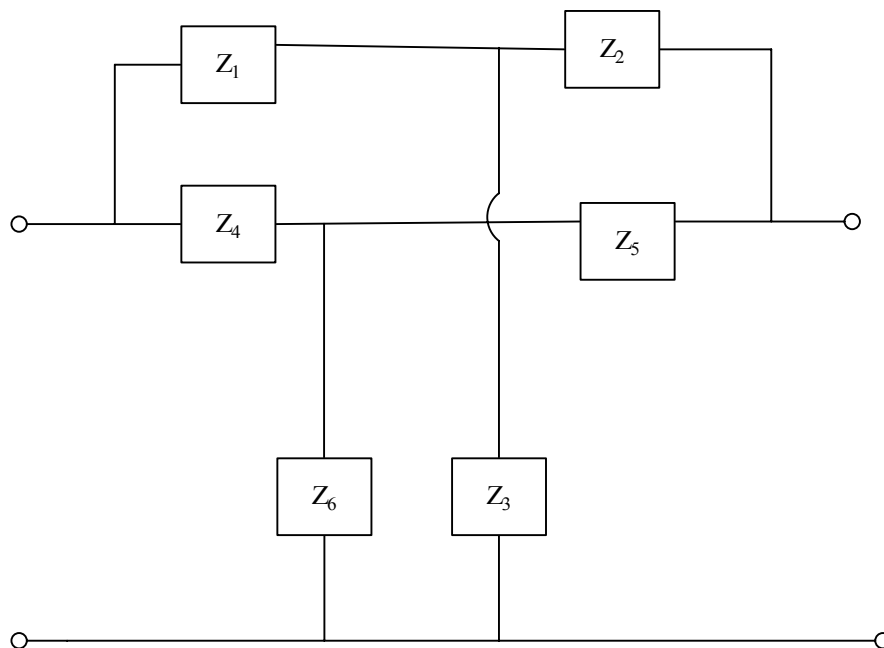

Suggested Solution

For one T network

$$Y_{11} = \frac{1}{Z_1 + Z_2 \parallel Z_3} = \frac{Z_2 + Z_3}{\Delta Z_{123}}$$

WHERE

$$Z_{123} = Z_1 Z_2 + Z_2 Z_3 + Z_1 Z_3$$

$$Y_{12} = Y_{21} = \frac{-Z_3}{\Delta Z_{123}}$$

$$Y_{22} = \frac{Z_1 + Z_3}{\Delta Z_{123}}$$

Then for the total network

$$Y_T = \begin{bmatrix} \frac{Z_2 + Z_3}{\Delta Z_{123}} + \frac{Z_5 + Z_6}{\Delta Z_{456}} & \frac{-Z_3}{\Delta Z_{123}} - \frac{Z_6}{\Delta Z_{456}} \\ \frac{-Z_3}{\Delta Z_{123}} - \frac{Z_6}{\Delta Z_{456}} & \frac{Z_2 + Z_3}{\Delta Z_{123}} + \frac{Z_5 + Z_6}{\Delta Z_{456}} \end{bmatrix}$$

Problem 15.36

Find the Z parameters of the network shown by considering the circuit to be a series connection of two port networks.

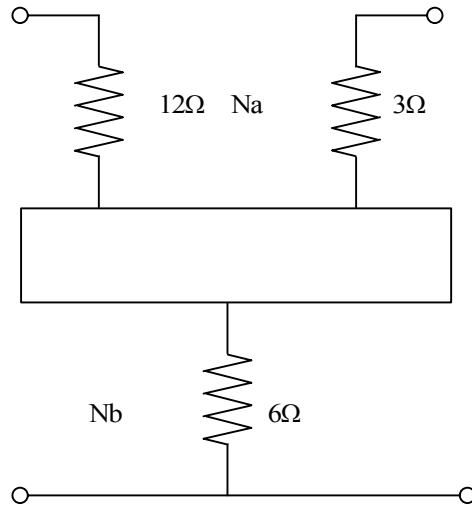

Suggested Solution

For N_A

$$Z_A = \begin{bmatrix} 12 & 0 \\ 0 & 3 \end{bmatrix}$$

For N_B

$$Z_B = \begin{bmatrix} 6 & 6 \\ 6 & 6 \end{bmatrix}$$

$$\therefore Z_T = Z_A + Z_B = \begin{bmatrix} 18 & 6 \\ 6 & 9 \end{bmatrix}$$

Problem 15.37

Find the transmission parameters of the network shown by considering the circuit to be a cascade connection of three two port networks.

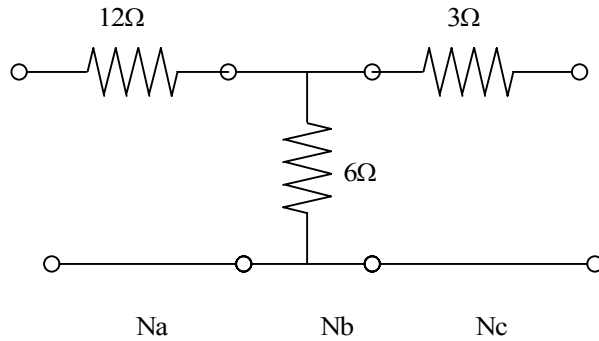

Suggested Solution

For N_a

$$\begin{bmatrix} 1 & 12 \\ 0 & 1 \end{bmatrix}$$

For N_b

$$\begin{bmatrix} 1 & 0 \\ \frac{1}{6} & 1 \end{bmatrix}$$

For N_c

$$\begin{bmatrix} 1 & 3 \\ 0 & 1 \end{bmatrix}$$

$$\therefore ABCD_T = \begin{bmatrix} 1 & 12 \\ 0 & 1 \end{bmatrix} \begin{bmatrix} 1 & 0 \\ \frac{1}{6} & 1 \end{bmatrix} \begin{bmatrix} 1 & 3 \\ 0 & 1 \end{bmatrix} = \begin{bmatrix} 3 & 21 \\ \frac{1}{6} & \frac{3}{2} \end{bmatrix}$$

Problem 15.38

Find the ABCD parameters for the circuit shown.

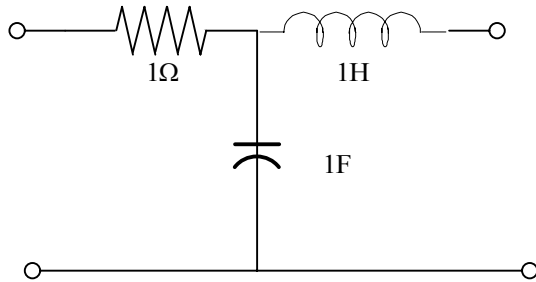

Suggested Solution

For the Resistor

$$\begin{bmatrix} A & B \\ C & D \end{bmatrix} = \begin{bmatrix} 1 & 1 \\ 0 & 1 \end{bmatrix}$$

For the Inductor

$$\begin{bmatrix} A & B \\ C & D \end{bmatrix} = \begin{bmatrix} 1 & 1 \\ j\omega & 1 \end{bmatrix}$$

For the Capacitor

$$\begin{bmatrix} A & B \\ C & D \end{bmatrix} = \begin{bmatrix} 1 & j\omega \\ 0 & 1 \end{bmatrix}$$

$$\begin{bmatrix} AB \\ CD \end{bmatrix} = \begin{bmatrix} 1+j\omega & 1+j\omega-\omega^2 \\ j\omega & 1-\omega^2 \end{bmatrix}$$

Problem 15.39

Find the transmission parameters for the two port network shown.

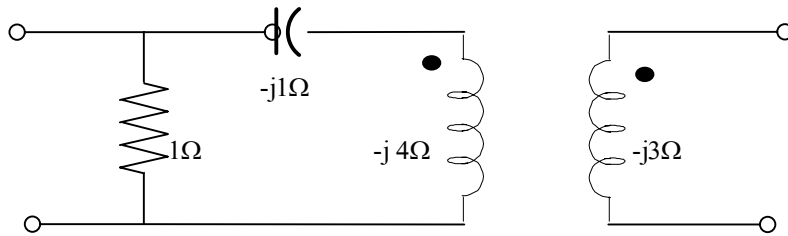

Suggested Solution

$$A = 1$$

$$C = 1$$

$$B = -j$$

$$D = -j$$

$$A = -1$$

$$C = -j$$

$$D = 3$$

$$B = j^{11}$$

$$\begin{bmatrix} A & B \\ C & D \end{bmatrix} = \begin{bmatrix} 1 & -j \\ 1 & 1-j \end{bmatrix} \begin{bmatrix} 4 & j^{11} \\ -j & 3 \end{bmatrix} = \begin{bmatrix} 3 & j8 \\ 3-j1 & 3+j8 \end{bmatrix}$$

Problem 15.40

Find the transmission parameters of the two port and then use the terminal conditions to find I.

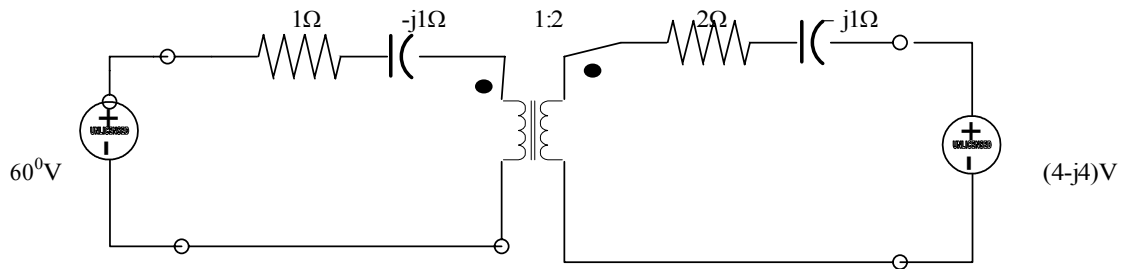

Suggested Solution

$$\begin{bmatrix} A & B \\ C & D \end{bmatrix} = \begin{bmatrix} 1 & 1-j \\ 0 & 1 \end{bmatrix} \begin{bmatrix} 0.5 & 0 \\ 0 & 2 \end{bmatrix} \begin{bmatrix} 1 & 2-j1 \\ 0 & 1 \end{bmatrix} = \begin{bmatrix} 0.5 & 3-j2.5 \\ 0 & 2 \end{bmatrix}$$

$$\therefore V_1 = 0.5V_2 + (3-j2.5)(-I_2)$$

$$I_1 = 2(-I_2)$$

$$V_1 = 6\angle 0$$

$$V_2 = 4-j4$$

$$I_0 = -I_2$$

$$\therefore 6\angle 0 = 0.5(4-j4) + (3-j2.5)(I_0)$$

$$I_0 = \frac{4+j2}{3-j2.5} = 1.14\angle 66.38^\circ \text{ A}$$

Problem 15FE-1

A two port network is known to have the following parameters

$$Y_{11} = 1/14s$$

$$Y_{12} = Y_{21} = -1/21s$$

$$Y_{22} = 1/7s$$

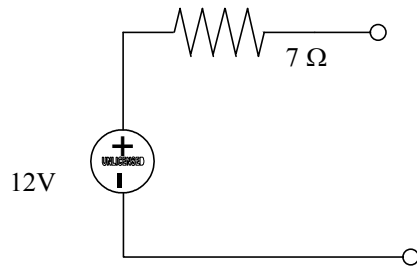
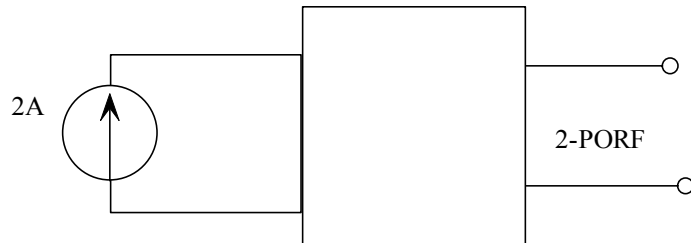

If a 2 A current source is connected to the input terminals, find the voltage across this source.

Suggested Solution

$$I_1 = Y_{11}V_1 + Y_{12}V_2$$

$$I_2 = Y_{21}V_1 + Y_{22}V_2$$

$$Z = \frac{1}{14}V_1 - \frac{1}{21}V_2$$

$$0 = \frac{-1}{21}V_1 + \frac{1}{7}V_2$$

$$\begin{bmatrix} V_1 \\ V_2 \end{bmatrix} = \frac{1}{\Delta Y} \begin{bmatrix} \frac{1}{7} & \frac{1}{21} \\ \frac{1}{21} & \frac{1}{14} \end{bmatrix} \begin{bmatrix} 2 \\ 0 \end{bmatrix}$$

WHERE

$$\Delta Y = \left(\frac{1}{14}\right)\left(\frac{1}{7}\right) - \left(\frac{1}{21}\right)\left(\frac{1}{21}\right) = \frac{3.5}{441}$$

CHECK

$$Z_{11} = \frac{Y_{22}}{\Delta Y} = \frac{1/3}{3.5/441} = 18$$

$$V_1 = (2)(Z_{11}) = 36V$$

$$V_1 = 36V$$

Problem 15FE-2

Find the Thevenin equivalent circuit at the output terminals of the network. of Problem 15FE1.

Suggested Solution

See previous solution.

$$V_2 = V_{oc} = 12V$$

$$Z_{TA} = \frac{1}{Y_{22}} = 7\Omega$$

The Thevenin equivalent circuit is

Problem 16.1

A diode has $I_s = 10^{-15}$ A and $n = 1$. Using the diode equation find I_d for $V_d = 0V, 0.25V, 0.5V, 0.75V$.

Suggested Solution

$$I_D = I_S [e^{V_D / nV_T} - 1] = 10^{-15} [e^{39V_D} - 1]$$

Vd(V)	Id(A)
0	0
0.25	1.7×10^{-11}
0.50	2.9×10^{-7}
0.75	5.0×10^{-3}

Problem 16.2

Plot an I_d - V_d curve for the diode in Problem 16.1 over the V_d range 0 to +0.65V. On the same graph, add curves for constant voltage and piece wise linear models for current between 10 to 100 μ A. What are your estimates for V_{on} , V_f and R_d .

Suggested Solution

At this level of study, selecting values for V_{on} , V_f and R_d is essentially a matter of preference. From the plot, the following values produce reasonable fits to the diode curve.

Constant voltage model = $V_{on} = 0.625V$

Piecewise linear model $V_f = 0.585V$ and $R_d = 740 \text{ ohm}$. Recall R_d is the reciprocal of slope of piecewise linear model I-V curve.

Problem 16.3

Repeat 16.1 using the constant voltage model with $V_{on} = 0.6V$

Suggested Solution

a. Diode is Forward biased

$$V_1 = 10 - 0.6 = 9.4V$$

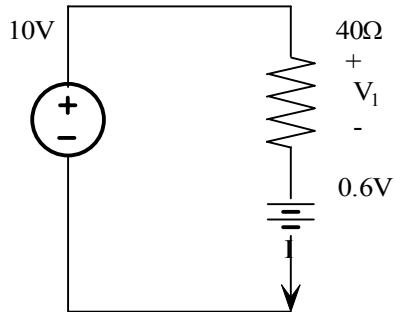

b. Diode is Reverse biased

$$V_1 = (0.1)(100) = 10V$$

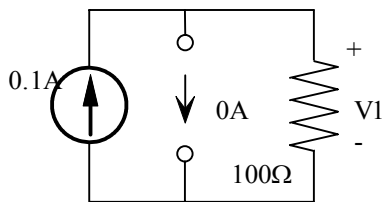

c. Diode is Forward biased

$$4 = 0.6 + V_1$$

$$V_1 = 3.4V$$

d. Diode is Reverse biased

$$I = \frac{4}{3k + 1k} = 1mA$$

$$V_1 = -I(1k) = -1V$$

C.

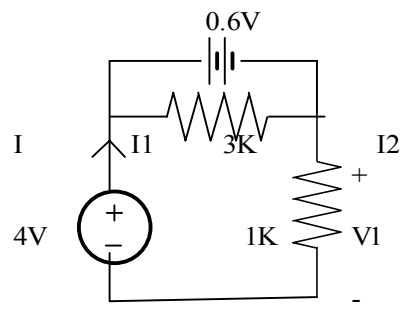

D.

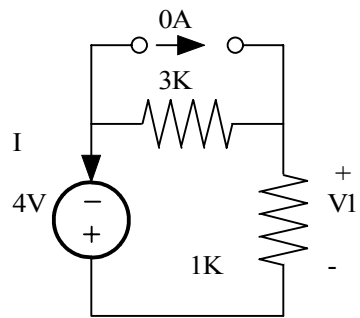

Problem 16.4

For the circuit shown find V_0 using a) the ideal model of diode, b) the constant voltage model with $V_{on} = 0.7\text{ V}$, and c) the piecewise linear model with $V_f = 0.6\text{ V}$ and $R_d = 10\text{ ohm}$. Give your self an attaboy if you can use the mathematical diode equation with $I_s = 1\text{e-}15\text{ A}$, $n = 1$ and $R = 1\text{ Kohm}$.

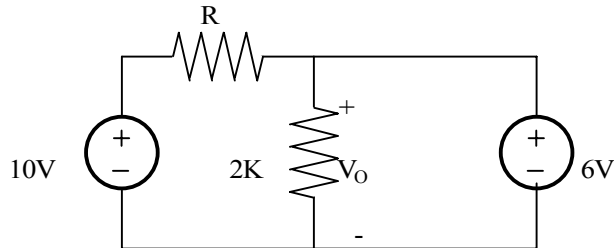

Suggested Solution

- a. Assume Diode is Reverse biased

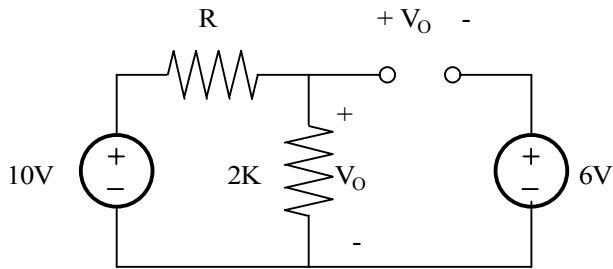

$$V_0 = 10 \left[\frac{2R}{2R + R} \right] = 6.67\text{ V}$$

$$V_D = V_0 - 6 = 0.67\text{ V}$$

Since $V_D > 0$, is our assumption was wrong. Try again with forward bias

- b. Assume reverse bias from a) $V_D = 0.67\text{ V}$, since $V_D < 0.7\text{ V}$ our assumption is good.

- c. Assume reverse bias from a) $V_D = 0.67\text{ V}$. Since $V_D > 0.6\text{ V}$, our assumption is bad. Try forward biased. By superposition

$$V_0 = 10 \left[\frac{2000 \parallel 10}{(2000 \parallel 10) + 1000} \right] + 6.6 \left[\frac{1000 \parallel 2000}{(1000 \parallel 2000) + 10} \right] = 6.6\text{ V}$$

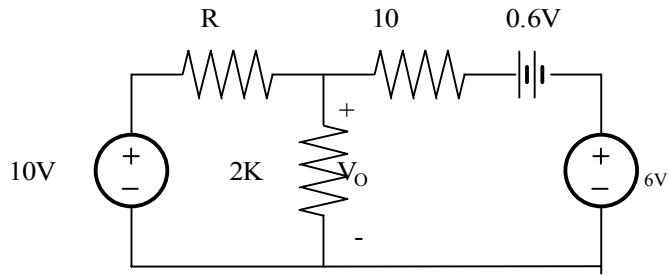

To use the diode equation, start by applying KCL at V_0

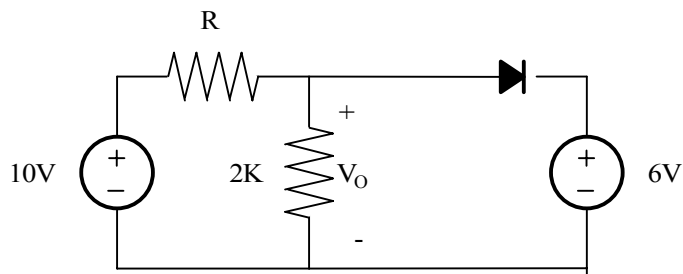

$$\frac{10 - V_0}{R} = \frac{V_0}{2R} + I_0$$

aLSO

$$V_0 = V_D + 6$$

Thus

$$\frac{10 - V_D - 6}{R} - \frac{V_D + 6}{2R} = I_D = \frac{1 - 1.5V_D}{R}$$

From the diode equation

$$V_D = nV_T \ln\left[\frac{I_D}{I_S} + 1\right]$$

and

$$I_D = \frac{1 - (3/2)nV_T \ln\left[\frac{I_D}{I_S} + 1\right]}{R}$$

can not be solved in closed form. We must iterate.

Procedure:

1. Guess a value for I_D
2. Substitute in right side of equation
3. Get answer for I_D
4. Put that value back in right side
5. When the difference between successive calculation is small, we have an answer.

This procedure is easy to automate in Excel. The excel values are shown

Id (mA) Guess	Id (mA) Result	Vd(V)
1.00E-01	2.58E-02	0.438
2.58 E-02	7.79 E-02	0.466
7.79 E-02	3.54 E-02	0.446
3.54 E-02	6.57 E-02	0.462
6.57 E-02	4.20 E-02	0.450
4.20 E-02	5.92 E-02	0.459
5.92 E-02	4.60 E-02	0.452
4.60 E-02	5.57 E-02	0.457
5.57 E-02	4.83 E-02	0.454
4.83 E-02	5.38 E-02	0.456
5.38 E-02	4.97 E-02	0.454
4.97 E-02	5.27 E-02	0.456
5.27 E-02	5.04 E-02	0.455
5.04 E-02	5.22 E-02	0.456
5.22 E-02	5.09 E-02	0.455
5.09 E-02	5.18 E-02	0.455
5.18 E-02	5.11 E-02	0.455
5.11 E-02	5.16 E-02	0.455
5.16 E-02	5.12 E-02	0.455
5.12 E-02	5.15 E-02	0.455
5.15 E-02	5.13 E-02	0.455
5.13 E-02	5.15 E-02	0.455
5.15 E-02	5.14 E-02	0.455
5.14 E-02	5.15 E-02	0.455
5.15 E-02	5.14 E-02	0.455
5.14 E-02	5.14 E-02	0.455

These are the final results.

Problem 16.5

The circuit in fig, is called half wave rectifier. Plot V_{in} and V_{out} verses time for 3 cycles of input voltage using a) the ideal diode model, b) constant voltage model with $V_{on} = 1.0V$

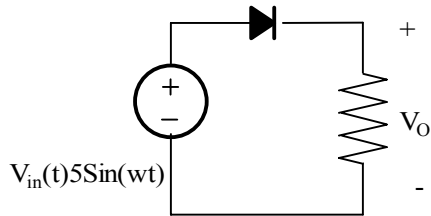

Suggested Solution

Using the ideal model procedures the circuits and b for forward and reverse bias conditions respectively. When $V_{in}(t)$ is positive, the diode is forward biased and $V_O(t) = 5 \sin(\omega t)$. Alternatively, when the diode is reversed biased $V_{in}(t)$ is negative and $V_O(t) = 0$.

The circuits, c and d model forward and reverse bias conditions respectively for the constant voltage model. When $V_{in}(t)$ is greater than V_{on} , the diode is forward biased and

$$V_O(t) = 5 \sin(\omega t) - 1$$

Else $V_O(t) = 0$, Plot V_O for both models.

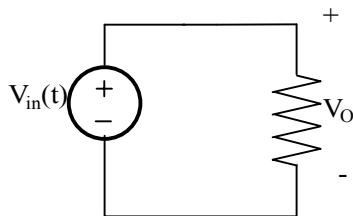
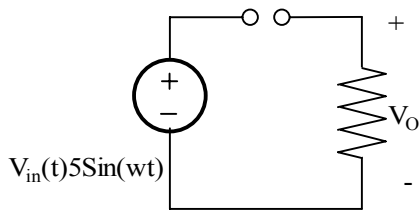

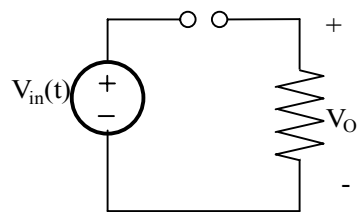
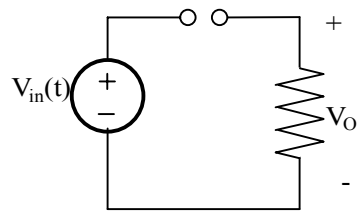

Problem 16.6

The MOSFET in fig, has $G_m = 1\text{mS}$, and $R_{ds} = 100\text{kohm}$. Draw the small signal circuit and find out the voltage gain V_o/V_{in} .

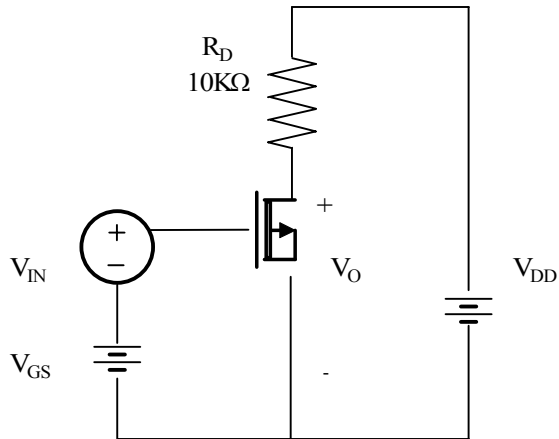

Suggested Solution

$$V_{GS} = V_{IN}$$

$$V_o = -g_M v_{gs} [r_{ds} \parallel R_D]$$

$$\frac{V_o}{V_{IN}} = -9.1$$

$$\frac{V_o}{V_{GS}} = -g_m [r_{ds} \parallel R_D] = -(1\text{m})[100\text{K} \parallel 10\text{K}] = -9.1$$

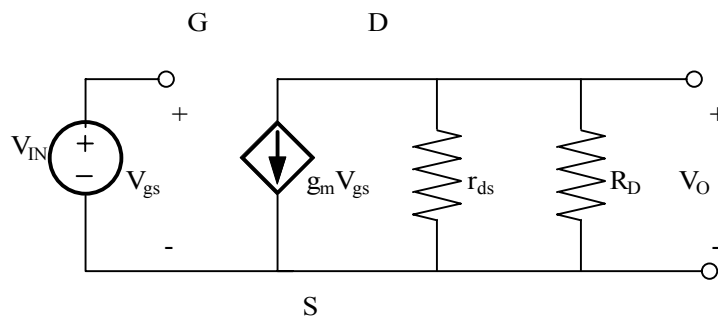

Problem 16.7

For the amplifier in problem 16.6 plot the gain V_0/V_{in} versus R_d for R_d between 1Kohm and 1Mohm. Why doesn't the gain increase linearly with R_d .

Suggested Solution

The small-signal model resistance R_{ds} is in parallel with R_d . For small values of R_d , it will dominate the parallel combination and the gain will be nearly linear with R_d . As R_d increases, the affect of R_{ds} becomes stronger until it dominates the combination and thus the gain.

Problem 16.8

The amplifier in fig is a common drain configuration. Find V_o/V_{in} and the output resistance, R_o in terms of G_m, R_{ds}, R_s . If $G_m = 10\text{mS}$ and $R_{ds} = 1\text{K}\Omega$. What is the value of R_o . What possible utility could this configuration have?

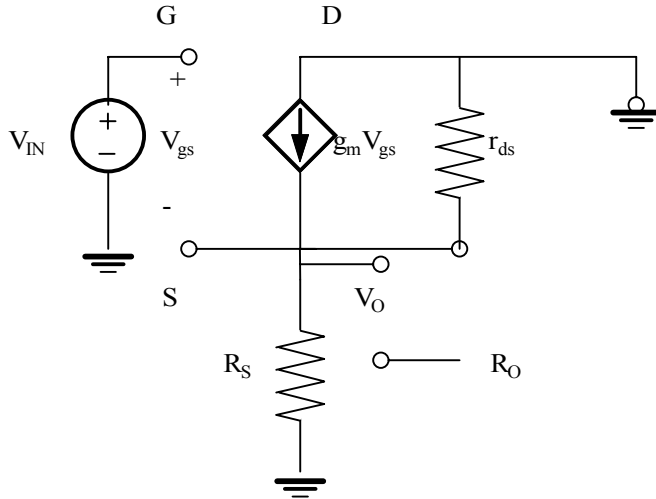

Suggested Solution

$$V_{GS} = V_{IN} - V_O$$

$$G_M V_{GS} = \frac{V_O}{R_{DS}} + \frac{V_O}{R_S}$$

$$R_S \parallel R_{DS}$$

$$G_M (V_{IN} - V_O) = \frac{V_O}{R_{DS} \parallel R_S}$$

$$G_M V_{IN} = V_O \left[G_M + \frac{1}{R_{DS} \parallel R_S} \right] \Rightarrow \frac{V_O}{V_{IN}} = \frac{G_M}{G_M + \frac{1}{R_{DS} \parallel R_S}}$$

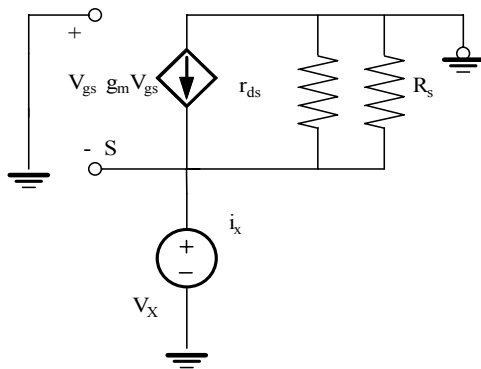

$$A = \frac{V_0}{V_{IN}} = \frac{G_M(R_S \parallel R_{DS})}{G_M(R_S \parallel R_{DS}) + 1}$$

Gain is positive and less than 1.

Rout : Eliminate V_{in} and apply a test source V_x at point of interest.

$$R_0 = \frac{V_x}{I_x}$$

$$V_x = V_{GS} = -V_{GS}$$

By KCL

$$I_x + G_M V_{GS} = \frac{V_x}{R_S \parallel R_{DS}}$$

$$I_x = V_x \left[G_M + \frac{1}{R_S \parallel R_{DS}} \right]$$

$$R_0 = \frac{V_x}{I_x} = \frac{R_{EG}}{G_M R_{EG} + 1}$$

Where

$$R_{EG} = R_S \parallel R_{DS}$$

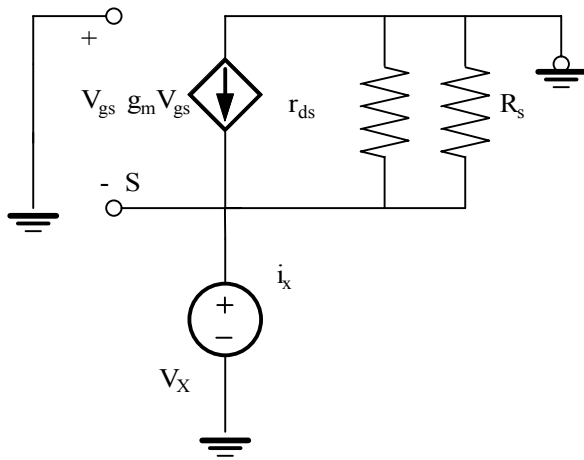

If $G_m R_{eq} \gg 1$, then $R_o = 1/G_m$, which is generally small.
 For $G_m = 10 \text{ mS}$, $R_{ds} = 1 \text{ k-ohm}$ and $R_s = 1 \text{ K-ohm}$
 $R_o = 83.3 \text{ ohm}$

The common drain configuration has a voltage near 1 and a low output resistance. It can serve as a voltage buffer much like the unity gain buffer op-amplifier.

Problem 16.9

For MOSFET in fig, $G_m = 2\text{mS}$ and assume R_{ds} is infinity. Using superposition find $V_o/(V_2 - V_1)$

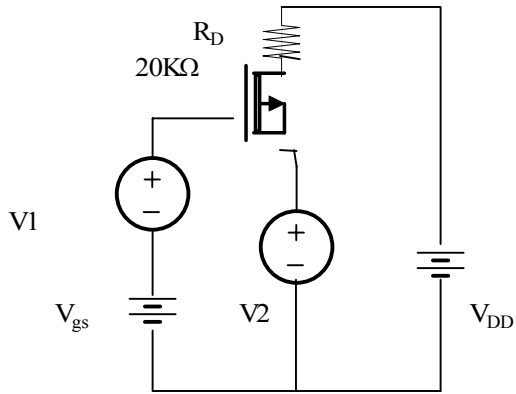

Suggested Solution

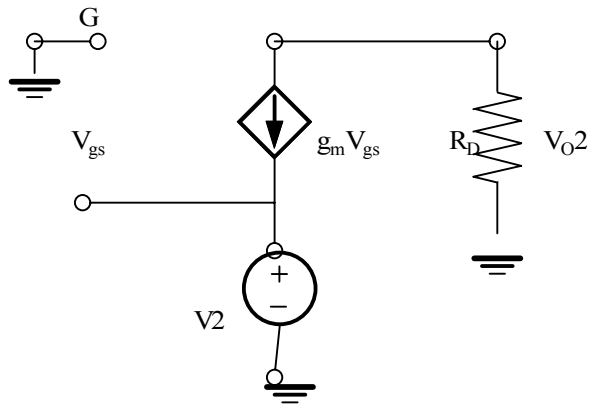
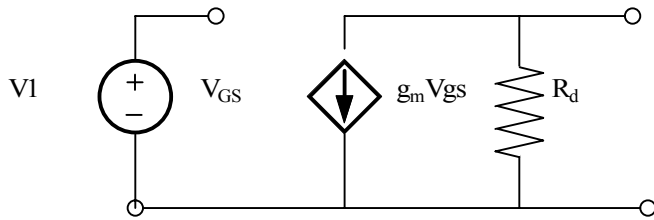

For V1

$$V_{GS} = V_1$$

$$V_{01} = -G_M R_D$$

$$V_{01} = -V_1 G_M R_D = -40V_1$$

For V2

$$V_{GS} = -V_2$$

$$G_M V_{GS} + \frac{V_{02}}{R_D} = 0$$

$$V_{02} = V_2 G_M R_D = 40V_2$$

$$V_0 = V_{01} + V_{02} = 40(V_2 - V_1)$$

$$\frac{V_0}{V_2 - V_1} = 40$$

$$\frac{V_0}{V_2 - V_1} = 40$$

Problem 16.10

The amplifier in Fig is called as a differential amplifier. MOSFETs M1 and M2 are identical devices with G_m values and V_1 and V_2 small signal inputs. Find Gain V_0/V_2-V_1 in terms of G_m and R_d . Assume R_{ds} is infinite.

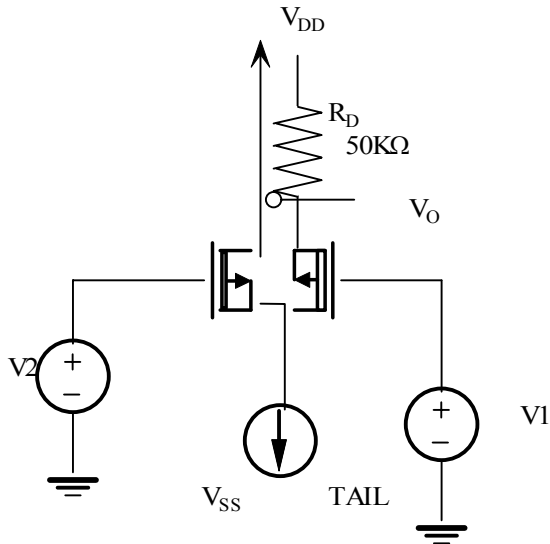

Suggested Solution

Use Superposition

$$V_2 = V_{GS2} - V_{GS1}$$

$$G_{M1} = G_{M2} = G_M$$

$$G_M V_{GS2} + G_M V_{GS1} = 0$$

$$V_{GS2} = -V_{GS1}$$

$$V_2 = 2V_{GS2} \Rightarrow V_{GS2} = \frac{V_2}{2} = -V_{GS1}$$

$$V_{02} = -G_{M1} V_{GS1} R_D = \frac{G_M R_D}{2} V_2 \Rightarrow V_{02} = V_2 \left(\frac{G_M R_D}{2} \right)$$

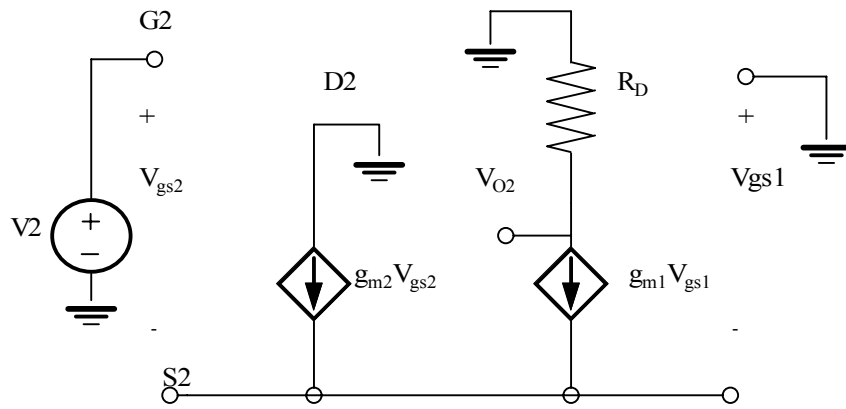

$$V_1 = V_{GS1} - V_{GS2}$$

$$G_{M1} = G_{M2} = G_M$$

$$G_M V_{GS2} + G_M V_{GS1} = 0$$

$$V_{GS2} = -V_{GS1}$$

$$V_{01} = -G_M V_{GS1} R_D = -V_1 \left(\frac{G_M R_D}{2} \right)$$

$$\frac{G_M R_D}{2} (V_2 - V_1) = V_0$$

$$V_0 = V_{01} + V_{02} = \frac{G_M R_D}{2} (V_2 - V_1) = V_0$$

Problem 16.11

Find an expression for the complex gain $A(j\omega) = V_o/V_{in}$ for the amplifier in terms of G_m , R_{ds} , R_D and C . Find expression for the gain at dc and pole zero location. For $G_m=500\mu S$ and $R_{ds}=400k\Omega$, graph bode plot over frequency range 1Hz-100KHz.

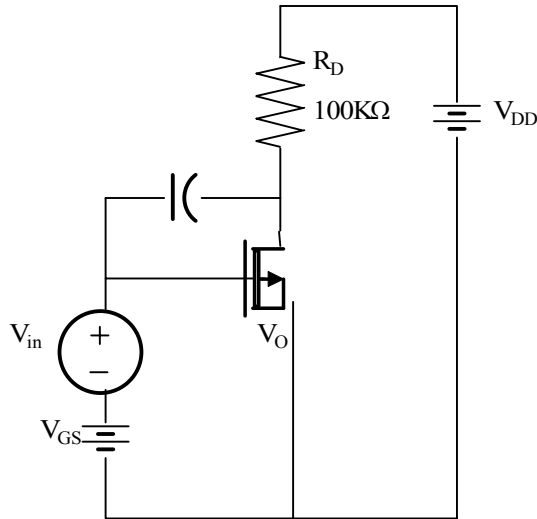

Suggested Solution

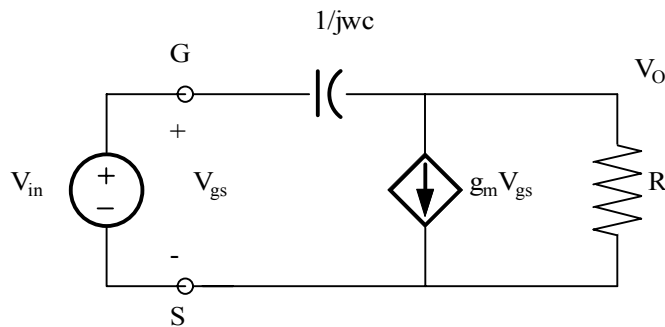

$$R = R_{DS} \parallel R_D = 80k\Omega$$

$$V_{GS} = V_{IN}$$

KCL :

$$(V_{IN} - V_o)j\omega C = G_M V_{GS} + \frac{V_o}{R} \Rightarrow V_{IN} (j\omega C - G_M) = V_o (j\omega C + \frac{1}{R})$$

$$A(j\omega) = \frac{V_0}{V_{IN}} = \frac{\left(\frac{j\omega C}{G_M} - 1\right)}{(j\omega CR + 1)} (G_M R)$$

Problem 16.12

The MOSFET in fig, acts as a switch to turn red LED on or off. On-resistance of MOSFET is given as $R_{on} = 2 / (V_{gs} - V_{th})$ where $V_{th} = 1V$. A LED is nothing more than a diode which glows when forward biased. The desired operating point for the LED is 2.0V at 20mA. Find R_{on} and the required value of R_1 .

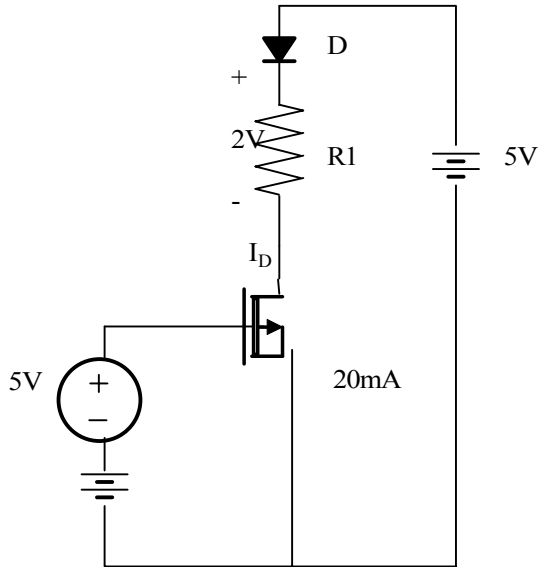

Suggested Solution

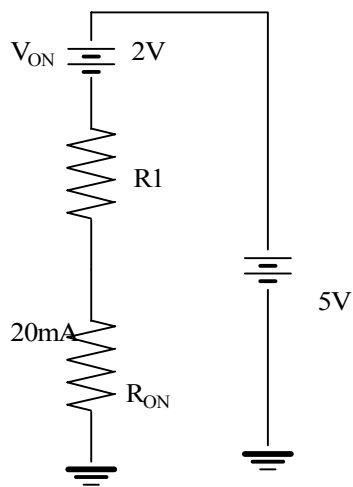

Equivalent Circuit

KCL:

$$5 = 2 + 0.02(R_1 + R_{ON})$$

$$R_{ON} = \frac{2}{V_{GS} - V_T} = \frac{2}{5 - 1} = 0.5\Omega$$

$$R_{ON} = 0.5\Omega$$

$$R_1 = 149.5\Omega$$

Problem 16.13

The MOSFET in fig are used to turn on a green ar red LED. V_{gs} is switched to either 0 or 3 V. Which voltage level turns on which LED? Use the constant voltage model for diodes with $V_{on} = 2.1$ V model the ON resistance of the MOSFET as $R_{on} = 17 / (V_{gs} - 0.75)$. Find the values of R_1 such that diode current never exceeds 10mA.

Suggested Solution

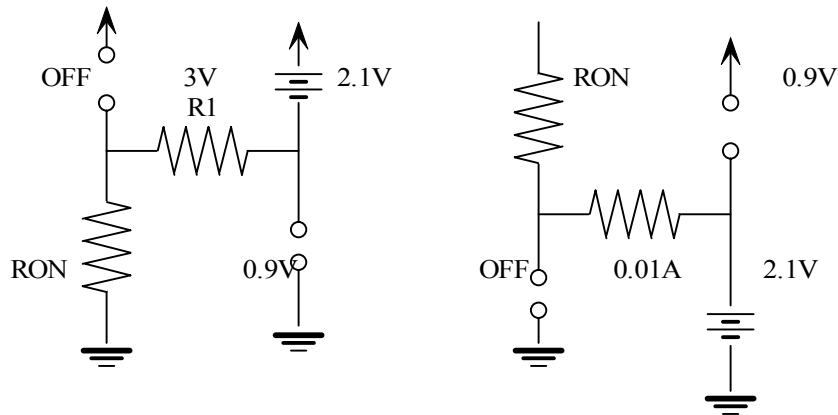

$$V_{GS} = 3V, V_{GS1} = 3V, V_{GS2} = 0V,$$

$$M_1 = ON, M_2 = OFF$$

$$R_{ON} = \frac{17}{3 - 0.75} = 7.55\Omega$$

KVL :

$$3 = 2.1 + 0.01(R_1 + R_{ON}) \Rightarrow R_1 \geq 82.4\Omega$$

$$V_{GS} = 0V, V_{GS1} = 0V, V_{GS2} = -3V,$$

$$M_1 = OFF, M_2 = ON$$

$$R_{ON} = 7.55\Omega$$

KVL :

$$3 = 0.01(R_1 + R_{ON}) + 2.1 \Rightarrow R_1 \geq 82.4\Omega$$

$$R_{ON} = 7.55\Omega$$

$$R_1 \geq 82.4\Omega$$

Problem 16.14

The MOSFET in fig. is used as a switch to turn on motor. It is desired that circuit operate at an efficiency at least 95% where efficiency is defined as

$$\eta = \frac{\text{Motor Power (W)}}{\text{Total Power (W)}}$$

Find the maximum allowable value of R_{ON} .

Suggested Solution

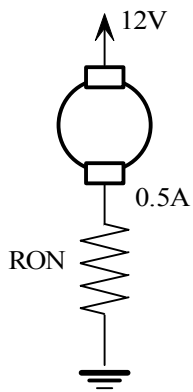

$$\text{Total Power} = 12 \left(\frac{1}{2} \right) = 6W$$

$$\text{Power in FET} = P_{FET} = I_2 R_{ON} = \frac{R_{ON}}{4}$$

$$R_{ON} \leq 1.2\Omega$$

$$\text{Total Power} = P_{MOTOR} + P_{FET} = 6W$$

$$\eta = \frac{6 - P_{FET}}{6} > 0.95 \Rightarrow P_{FET} < 0.3W = \frac{R_{ON}}{4}$$

Problem 16.15

Fig shows an electric car motor can be controlled by a MOSFET. For the conditions shown find the efficiency of the circuit and MOSFET power when $R_{on} = 5\text{mohm}$. Efficiency is defined as

$$\eta = \frac{\text{Motor Power (W)}}{\text{Total Power (W)}}$$

Find the values of R_{on} required for 99% efficiency. As mentioned in the text, MOSFETs, with R_{on} values as low as 2mohm are commercially available (circa 2000). How can you produce the required R_{on} value.

Suggested Solution

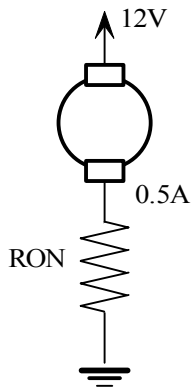

$$\text{Total Power} = P_{\text{MOTOR}} + P_{\text{FET}}$$

$$\begin{aligned} &= 50(600) + I^2 R_{ON} \\ &= 30000 + 600^2 (5M) \\ &= 31800W \end{aligned}$$

$$\eta = \frac{30000}{31800} = 94.3\%$$

for

$$\eta = 99\% = \frac{30k}{30k + P_{\text{FET}}} \Rightarrow P_{\text{FET}} = 303W$$

$$R_{ON} = \frac{P_{\text{FET}}}{I^2} = \frac{P_{\text{FET}}}{600^2} = 0.84\text{m}\Omega$$

$$\eta = \frac{30000}{31800} = 94.3\%$$

$$R_{ON} = \frac{P_{FET}}{I^2} = \frac{P_{FET}}{600^2} = 0.84m\Omega$$

Less than currently available 2mΩ units.

Solution:

Use several identical devices in parallel. If 5 are used with $R_{on} = 4 \text{ m}\Omega$, then the combined

$$R_{ON} = \frac{4}{5} \text{ m} = 0.8 \text{ m}\Omega$$

Problem 16FE-1

For the circuit sketch voltage V_o versus V_{in} , over the range -10V to 10V . What are the bias conditions for the diodes at $V_{in}=-10$, 0 and $+10\text{ V}$. Assume diodes are ideal.

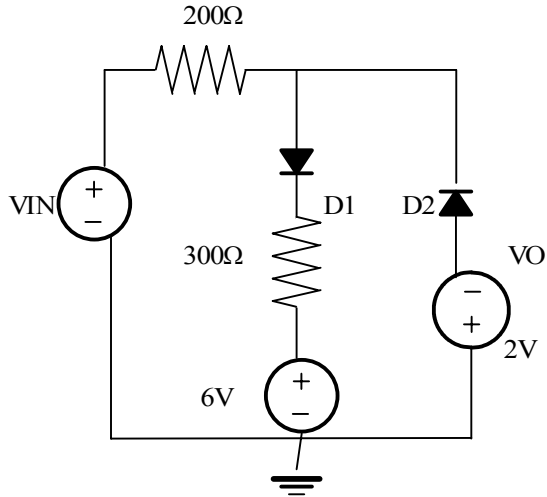

Suggested Solution

When V_{in} is greater than 6 V , $D1$ is forward biased and $D2$ is reverse biased. The circuit reduces to that where

$$V_{IN} = 500I + 6$$

$$V_o = 300I + 6$$

$$V_o = 6 + 0.6(V_{IN} - 6)$$

When V_{in} is less than -2 V , $D2$ is forward biased and $D1$ is reverse biased. Under these conditions $V_o = -2\text{V}$

For V_{in} between -2 V and 6 V , both diodes are reverse biased, no flows anywhere. And $V_o = V_{in}$.

A plot is shown

Problem 16FE-2

The MOSFET in the circuit acts as a switch with an resistance of 1ohm and diode is ideal.

- a. Assume the MOSFET is on the network has reached steady state. What is the value of Inductor current.
- b. With the current operating as described in a) the MOSFET is turned off at time 0. Find expression for $i_L(t)$ and $V_L(t)$, for $t \geq 0$.

Suggested Solution

- A. The figure shown models the circuit when MOSFET is ON. In steady state, the inductor voltage is 0, yielding,

$$20 = 5I_L$$
$$I_L = 4 \text{ A}$$

- B. The circuit models transients in the circuit when the MOSFET turns OFF. The initial condition of the inductor current is found a) to be 4A. When MOSFET turns off, the inductor current cannot go to 0 instantaneously. It flows through diode and discharges inductor. The inductor current and voltage can be given as

$$i_L(t) = K_1 + K_2 e^{-\frac{t}{\tau}}$$

$$V_L(t) = K_3 + K_4 e^{-\frac{t}{\tau}}$$

where $i_L(0) = 4 \text{ A}$ and $i_L(\infty) = 0 \text{ A}$. Thus $K_1 = 0$ and $K_2 = 4 \text{ A}$. Similarly, $V_L(0) = -I_L(0)R = -16 \text{ V}$ and $V_L(\infty) = 0 \text{ V}$. Thus $K_3 = 0$ and $K_4 = -16 \text{ V}$. The time constant $\tau = 25 \text{ micro sec}$. The resulting expressions for current and voltage are

$$i_L(t) = 4e^{-40000t}$$

$$V_L(t) = -16e^{-40000t}$$

